

Features

- +45 dBm Typical IP3
- 1W Typical Output Power
- 14 dB Typical Gain
- Single Positive Bias
- Surface Mount Package or Half Flange Package

The MPS173011 is a modular amplifier designed to meet the ultralinear transmitter output requirements of worldwide PDC systems. The amplifier is a class A, single stage amplifier based on a GaAs MESFET transistor. The amplifier exhibits an extremely high IP3 (+45dBm) relative to the DC power consumed (3 W). The device is self contained with all matching and bias circuitry included. The device has a P1dB of +30 dBm at a supply voltage of +7.5 Vdc. The unit is extremely flat (less than .5 dB gain variation) from 1.4 GHz to 1.7 GHz.

Specifications

- Electrical at 25°C, V_{dd}= 7.5 V, Z_o= 50 Ω

Symbol	Parameter	Min.	Typical	Max	Unit
Freq	Frequency Range	1400		1700	MHz
SSG	Small Signal Gain	13	14		dB
P1dB	P out at 1 dB Compression		+30.0		dBm
IP3	Third-order Intercept	+42.0	+45.0		dBm
VSWR	Input VSWR		1.5:1/2.2:1		
ΔGOF	Gain Variation over Freq.		+/- 0.25	+/- 0.50	dB
ΔGOT	Gain Variation over Temp.		-.01		dB/°C
I _{dd}	DC Current		350	420	mA

Gain vs. Frequency

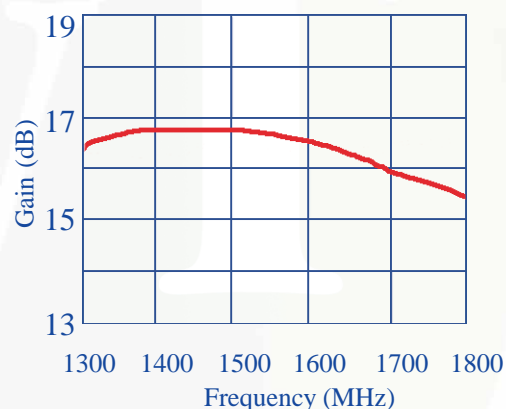

Output Power at P1dB

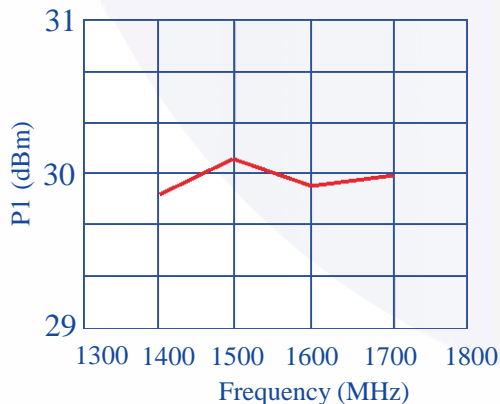

Absolute Maximum Ratings

Maximum Bias Voltage	8.0 V
Maximum Continuous RF Input Power	950 mW
Maximum Peak Input Power	1400mW
Maximum Case Operating Temperature	+85°C
Maximum Storage Temperature	-65°C to +150°C

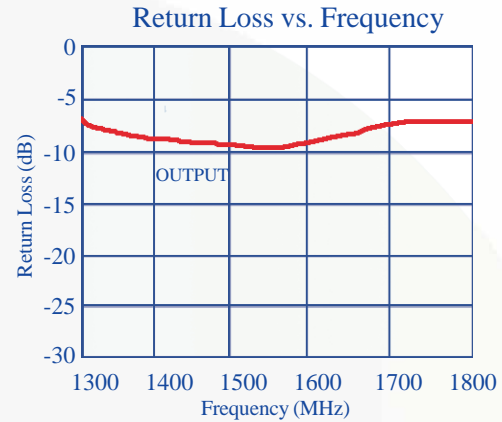
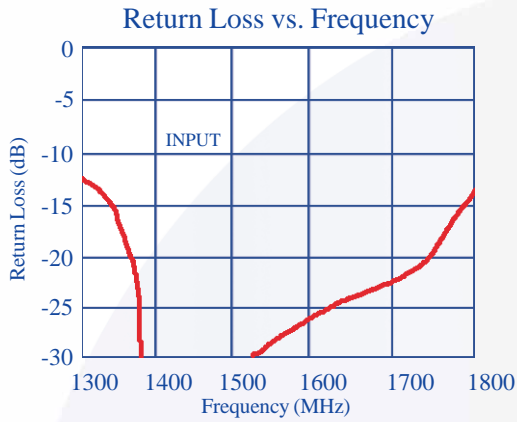

Outline Diagrams

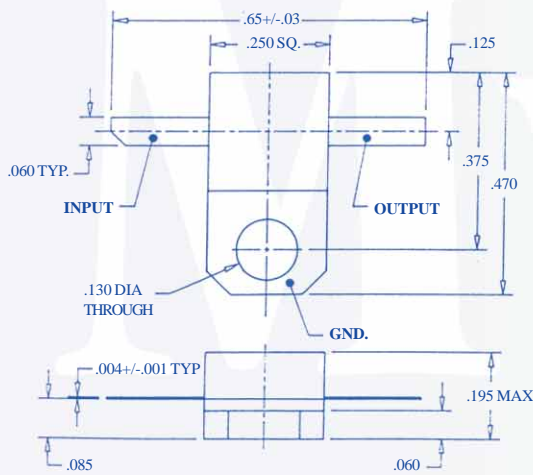

Package 85

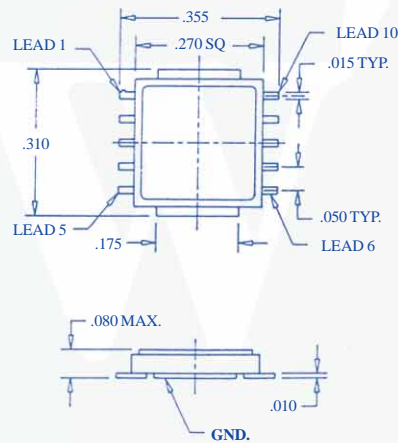

Package 86 (HERMETIC)

Pin	Connection
1	N/C
2	N/C
3	RF Input
4	N/C
5	N/C
6	N/C
7	N/C
8	RF Output, Vdd
9	N/C
10	N/C
Case	Ground

Application Circuit

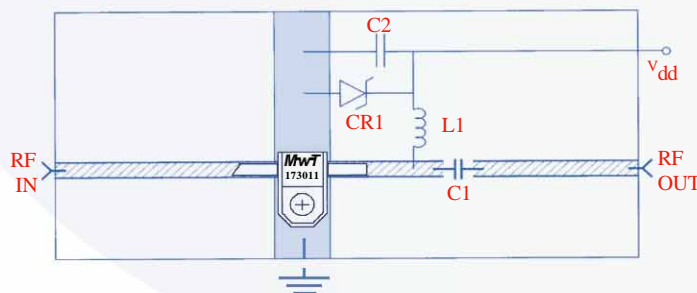

- C1 100 pF Chip Capacitor
 - C2 .22 pF Capacitor
 - L1 160 nH Printer or Wound Coil
 - CR1 8.0 V Zener Diode
- 50 Ω Microstrip Line