

# DATA IMAGE CORPORATION

## LCD Module Specification

ITEM NO.: SG322400CNCWA-T1

### Table of Contents

1. COVER & CONTENTS .....	1
2. RECORD OF REVISION .....	2
3. GENERAL SPECIFICATIONS .....	3
4. ABSOLUTE MAXIMUM RATINGS .....	4
5. ELECTRICAL CHARACTERISTICS .....	5
6. ELECTRO-OPTICAL CHARACTERISTIC .....	6
7. TIMING CHARACTERISTICS .....	8
8. PIN CONNECTIONS .....	12
9. POWER SUPPLY .....	12
10. BLOCK DIAGRAM .....	13
11. TOUCH PANEL CHARACTERISTICS.....	14
12. QUALITY ASSURANCE .....	15
13. LOT NUMBERING SYSTEM .....	19
14. LCM NUMBERING SYSTEM .....	19
15. PRECAUTIONS IN USE LCM .....	20
16. OUTLINE DRAWING .....	21
17. PACKAGE INFORMATION .....	22

R&D Dept.	Q.C. Dept.	Eng. Dept.	Prod. Dept.
Version:	Issued Date:	Sheet Code:	Total Pages:
c	2002/10/3		22



### 3. GENERAL SPECIFICATION

Display Format : 320x3(R.G.B) (W) × 240 (H) dots  
Dot Size : 0.1 (W) × 0.34 (H) mm  
Dot Pitch : 0.12 (W) × 0.36 (H) mm  
View Area : 120 (W) × 90 (H) mm  
General Dimensions : 165.8 (W) × 109 (H) × 9.2 (T) mm Max.  
Weight : 200 g max.

LCD Type :  STN Color  STN Yellow  FSTN  TN

Polarizer mode :  Reflective  Transflective

Transmissive  Negative

Display dots  Black   Others

View Angle :  6 O'clock  12 O'clock  Others

Backlight :  LED  EL  CCFL

Backlight Color :  Yellow green  Amber  Blue Green

White  Others

Controller / Driver : HD66131/HD66134

Duty Ratio 1/240

Temperature Range :  Normal  Wide Temperature  
Operating 0 to 50°C Operating -20 to 70°C  
Storage -20 to 60°C Storage -30 to 80°C

## 4. ABSOLUTE MAXIMUM RATINGS

### 4.1 ELECTRICAL ABSOLUTE MAXIMUM RATINGS

$V_{SS}=0V$ ,  $T_a = 25^{\circ}C$

Item	Symbol	Min.	Max.	Unit
Supply Voltage (Logic)	$V_{DD-VSS}$	0	6.0	V
Supply Voltage (LCD Driver)	$V_{CON}$	0	$V_{DD}$	V
Input Voltage	$V_i$	-0.3	$V_{DD}+0.3$	V
Input Current	$I_i$	0	1	A
Operating Temperature	$T_{OP}$	0	50	$^{\circ}C$
Storage Temperature	$T_{STG}$	-20	60	$^{\circ}C$

### 4.2 ENVIRONMENTAL ABSOLUTE MAXIMUM RATINGS

Item	Operating		Storage		Comment
	(Min.)	Max.)	(Min.)	(Max.)	
Ambient Temp	0	50	-20	60	Note(2),(3),(6)
Humidity	Note (1)		Note(1)		Without Condensation
Vibration	--	$2.45M/S^2$	--	$11.76M/S^2$ Note(5)	1 h max Note (4)
Shock	--	$29.4M/S^2$	--	$490M/S^2$ Note(5)	XYZ Direction 11ms

Note(1)  $T_a \leq 40^{\circ}C$  : 85%RH Max.

$T_a > 40^{\circ}C$  : Absolute humidity must be lower than the humidity of 85%RH at  $40^{\circ}C$ .

Note(2)  $T_a$  at  $-20^{\circ}C < 48$  hrs, at  $60^{\circ}C < 168$  hrs.

Note(3) Background color changes slightly depending on ambient temperature. This phenomenon is reversible.

Note(4) 5HZ~100Hz(Except resonance frequency).

Note(5) The LCM will resume normal operation after finishing the test.

Note(6) The LCM will be operated less than  $5^{\circ}C$ . The life time of CFL will reduced need to make sure of value IL and characteristics of inverter, also the response time less than  $5^{\circ}C$  will be slower.

## 5. ELECTRICAL CHARACTERISTICS

Item	Symbol	Condition	Min.	Typ.	Max.	Unit
Supply Voltage (Logic)	V <sub>DD</sub> -V <sub>SS</sub>		4.5	5.0	5.5	V
Supply Voltage (LCD)	V <sub>CON</sub> -V <sub>SS</sub>	0°C	2.5	2.7	3.0	V
		25°C	2.4	2.6	2.8	
		50°C	2.3	2.5	2.7	
Input Voltage	V <sub>IH</sub>	--	0.8*V <sub>DD</sub>	--	V <sub>DD</sub>	V
	V <sub>IL</sub>		V <sub>SS</sub>	--	0.2*V <sub>DD</sub>	
Logic Supply Current	I <sub>DD</sub>	V <sub>DD</sub> -V <sub>SS</sub> =5.0V		12	15	mA

## 6. ELECTRO-OPTICAL CHARACTERISTICS

ITEM	Symbol	Condition	Min.	Typ.	Max.	Unit	Ref.
Response time (rise , fall)	tr	$\theta = 0^\circ, \phi = 0^\circ$	--	250	--	ms	Note (4)
	tf		--	200	--		
View Angle	$\phi_2 - \phi_1$	$\theta = 0^\circ, K \geq 2.0$	--	40	--	deg	Note (1), Note (2)
Contrast ratio	K	$\theta = 0^\circ, \phi = 0^\circ$	--	40	--		Note(3)
Brightness			87	100	--	cd/m <sup>2</sup>	
Frame Frequency	fFLM	25°C	60	70	80	Hz	
Color tone (Primary Color)	Red	X	$\theta = 0^\circ, \phi = 0^\circ$	--	0.507	--	Note(5)
		Y		--	0.306	--	
	Green	X		--	0.312	--	
		Y		--	0.508	--	
	Blue	X		--	0.162	--	
		Y		--	0.194	--	
	White	X		--	0.300	--	
		Y		--	0.330	--	

Measured by :TOPCON BM-7

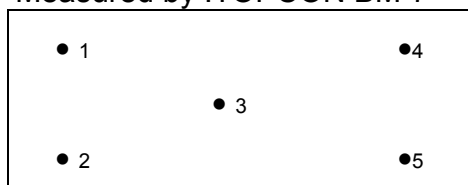

$$\text{Brightness} = \frac{1+2+3+4+5}{5}$$

Note 1~5:See next page.

Note 1. Definition of  $\theta$  and  $\phi$  (Normal) Viewing direction

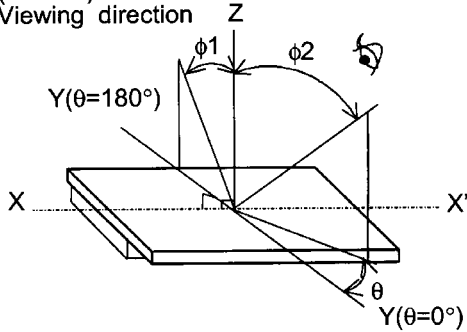

Note 3. Definition of contrast "K"

$$K = \frac{\text{Brightness on selected area (B1)}}{\text{Brightness on non-selected area (B2)}}$$

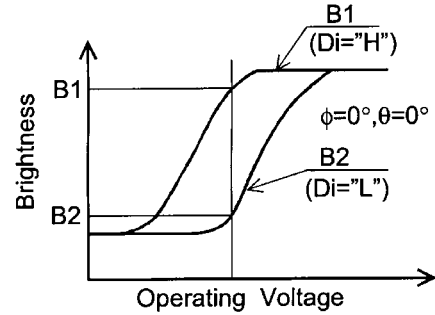

Note 2. Definition of viewing angle  $\phi_1$  and  $\phi_2$

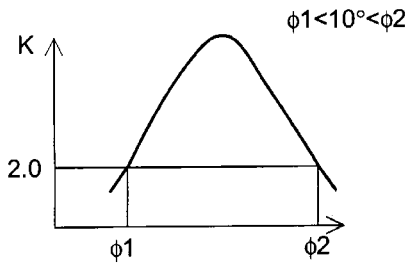

Contrast ratio k vs viewing angle  $\phi$

Note 4. Definition of optical response time

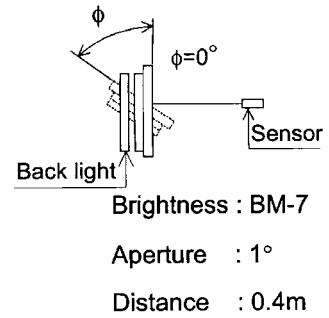
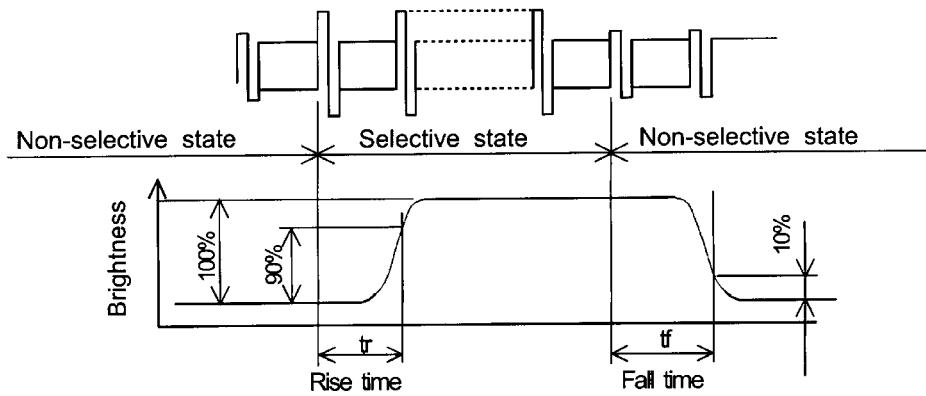

Note 5. The LCD driving voltage should be adjusted at the voltage where the peak contrast is obtained.

## 6.1 CCFL ELECTRICAL CHARACTERISTIC

Item	Condition
Start Voltage	500 Vrms min,at Ta=25°C
Tube Voltage	300Vrms typ,at Ta=25°C
Tube Current	5m Arms typ ,at Ta=25°C
Drive Frequency	30 KHz , typ at Ta=25°C
Life time	Min=15KHrs TYP=20 KHrs

### Recommend CCFL inverter:

TDK L10L operation voltage +12V , 300mA

TDK L10A operation voltage +5V , 600mA

## 7. TIMING CHARACTERISTIC

VDD=5.0V , VSS=0V , Vcon=0.8~2.8V , Ta=0~50 °C

Characteristics	Symbol	Min.	Typ.	Max.	Unit
CL1 Pulse width H	$t_{WHCL1}$	45	-	-	ns
Clock cycle time	$t_{CYC}$	25	-	-	ns
CL2 Pulse width H	$t_{WHCL2}$	10	-	-	ns
Clock setup time	$t_{SCL1}$	20	-	-	ns
Clock hold time	$t_{HCL1}$	50	-	-	ns
Clock rise fall time	$t_r, t_f$	-	-	30	ns
Data setup time	$t_{DSU}$	6	-	-	ns
Data hold time	$t_{DH}$	6	-	-	ns
FLM setup time	$t_{FS}$	50	-	-	ns
FLM hold time	$t_{FH}$	50	-	-	ns

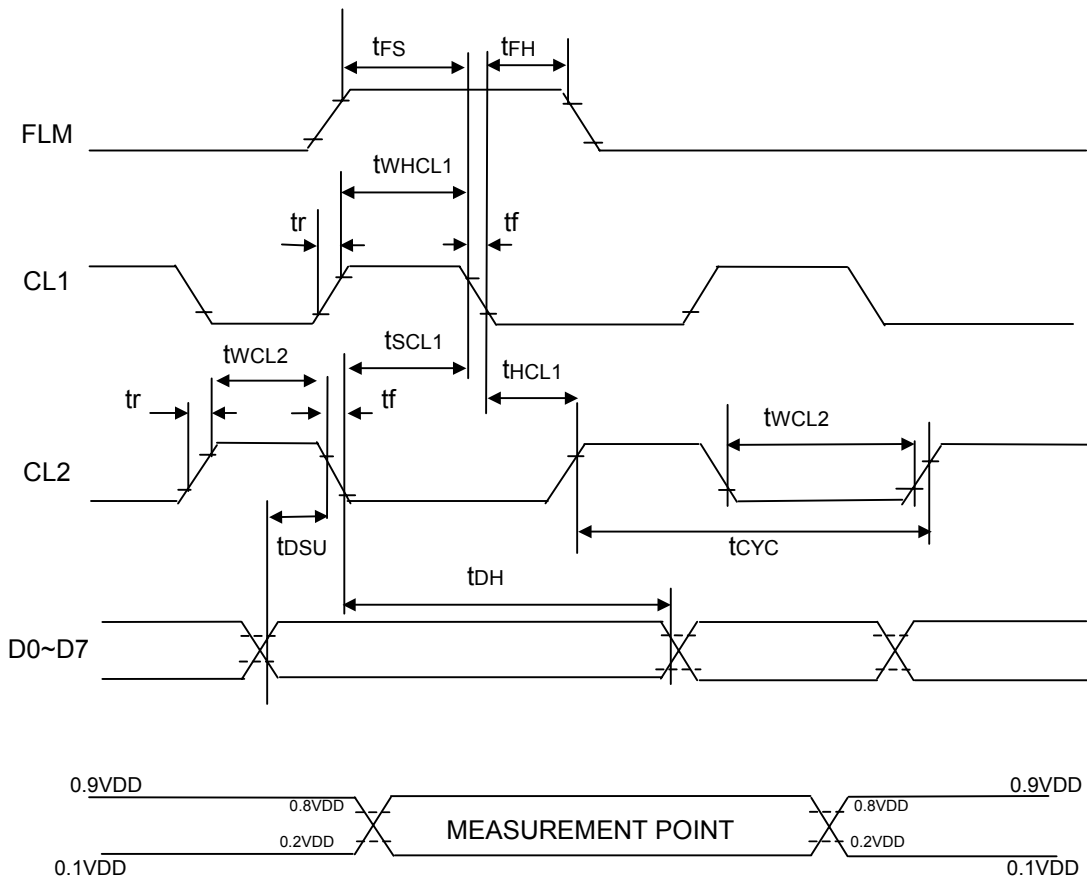



### 7.1 TIMING CHART

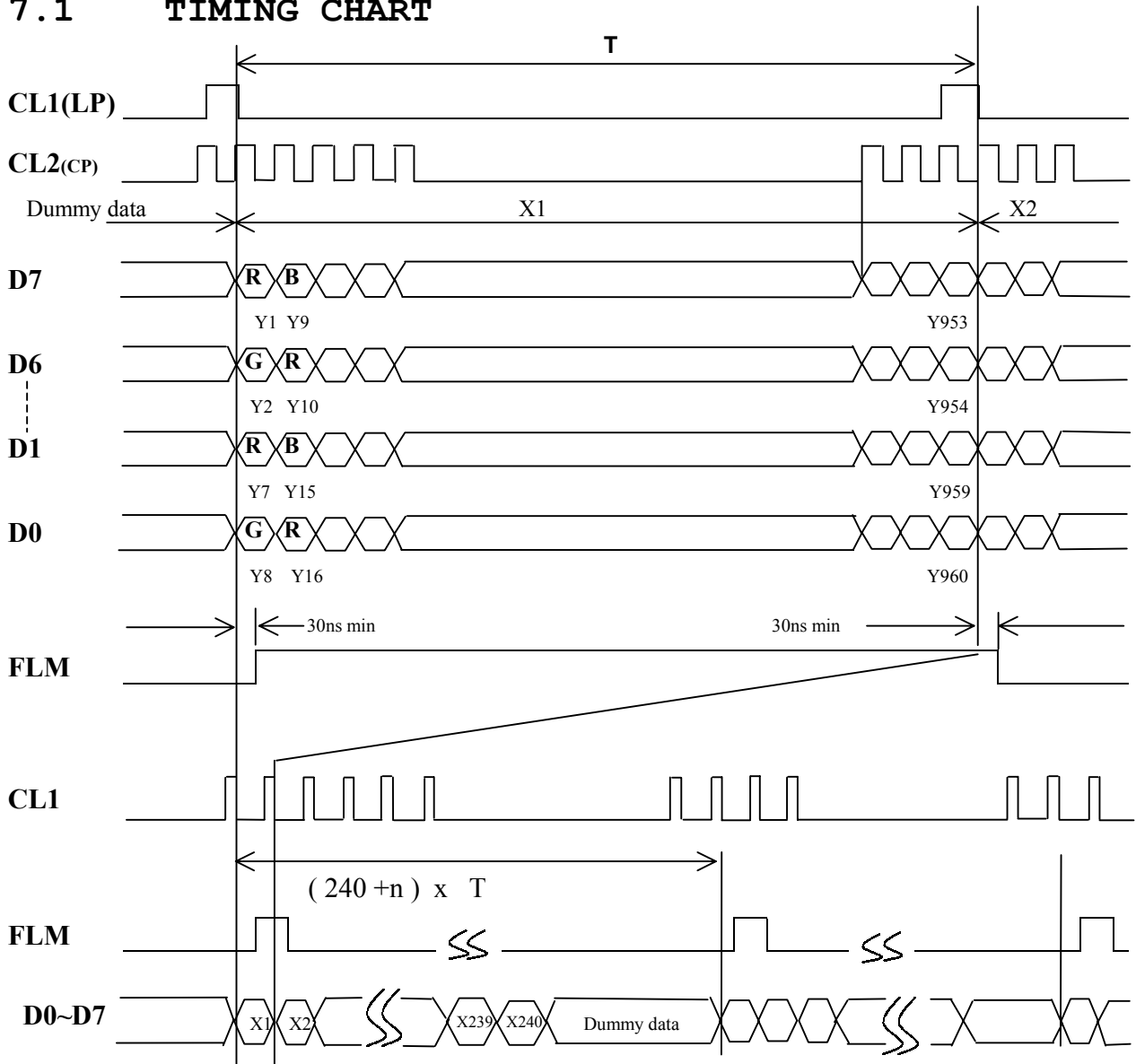

## 7.2 POWER ON/OFF SEQUENCE

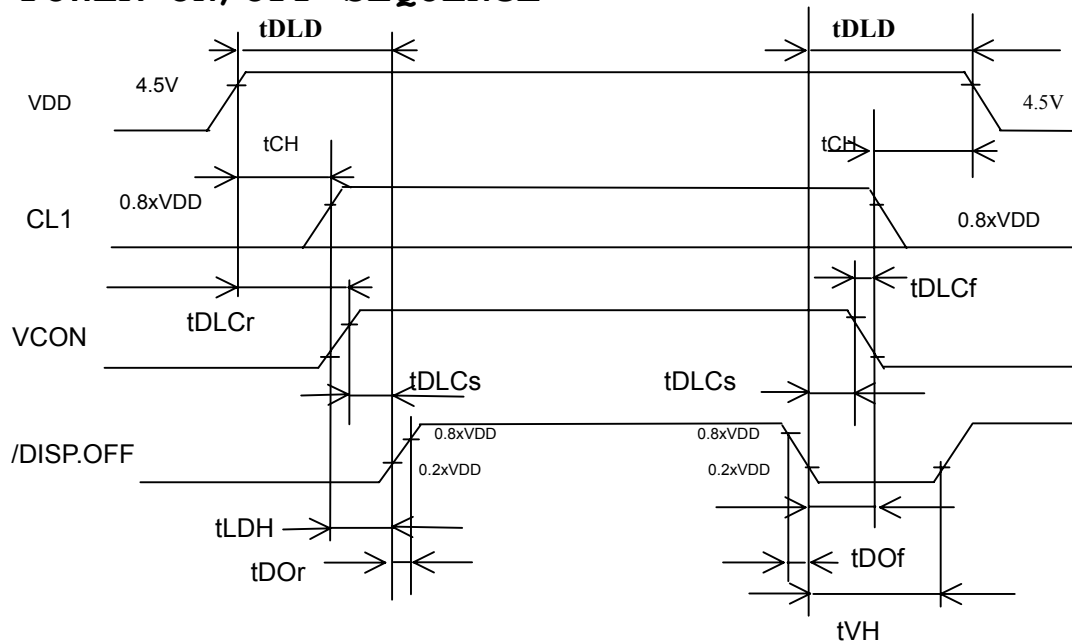

Symbol	Min.	Max.	Unit	Comment
tDLD	200	-	ms	Note1 Note2
tCH	0		ms	
tLDH	0		ms	
tDOr		100	ns	
tDOF		100	ns	
tDLCr	20		ms	
tDLCf	0		ms	
tDLCs	20		ms	
tVH	200		ms	

Note1: Please keep the specified sequence because wrong sequence may cause permanent damage to the LCD panel.

Note2: We recommend you to use /DISPOFF function.

Display quality may deteriorate if you don't use /DISPOFF function.

### 7.3 INPUT DATA ALLOCATION TABLE

Data Signal	D7	D6	D5	D4	D3	D2	D1	D0	D7		D2	D1	D0
X \ Y	1	2	3	4	5	6	7	8	9		958	959	960
1	R	G	B	R	G	B	R	G	B		R	G	B
2	R	G	B	R	G	B	R	G	B		R	G	B
3	R	G	B	R	G	B	R	G	B		R	G	B
4	R	G	B	R	G	B	R	G	B		R	G	B
5	R	G	B	R	G	B	R	G	B		R	G	B
6	R	G	B	R	G	B	R	G	B		R	G	B
7	R	G	B	R	G	B	R	G	B		R	G	B
8	R	G	B	R	G	B	R	G	B		R	G	B
⋮													
231	R	G	B	R	G	B	R	G	B		R	G	B
232	R	G	B	R	G	B	R	G	B		R	G	B
233	R	G	B	R	G	B	R	G	B		R	G	B
234	R	G	B	R	G	B	R	G	B		R	G	B
235	R	G	B	R	G	B	R	G	B		R	G	B
236	R	G	B	R	G	B	R	G	B		R	G	B
237	R	G	B	R	G	B	R	G	B		R	G	B
238	R	G	B	R	G	B	R	G	B		R	G	B
239	R	G	B	R	G	B	R	G	B		R	G	B
240	R	G	B	R	G	B	R	G	B		R	G	B

R=Red  
 G=Green  
 B=Blue

## 8. PIN CONNECTIONS

CN1

No.	Symbol	Function
1	FLM	H/L First Line Marker
2	CL1(LP)	H→L Data Latch Clock
3	CL2(CP)	H→L Clock Signal for Shifting Data
4	/DISPOFF	<b>H:</b> Display ON <b>L:</b> Display OFF
5	VDD	Power Supply for logic circuit
6	VSS	Power Supply (OV, Ground)
7	VCON	LCD Contrast Voltage input
8	D0	Display data
9	D1	
10	D2	
11	D3	
12	D4	
13	D5	
14	D6	
15	D7	
16	VSS	Power Supply (OV, Ground)

CN2

No.	Symbol	Function
1	HOT	CCFL HOT
2	NC	No Connection
3	GND	CCFL GND

TOUCH PANEL

No.	Symbol	Function
1	TOP	for touch panel
2	Bottom	
3	Left	
4	Right	

## 8. POWER SUPPLY

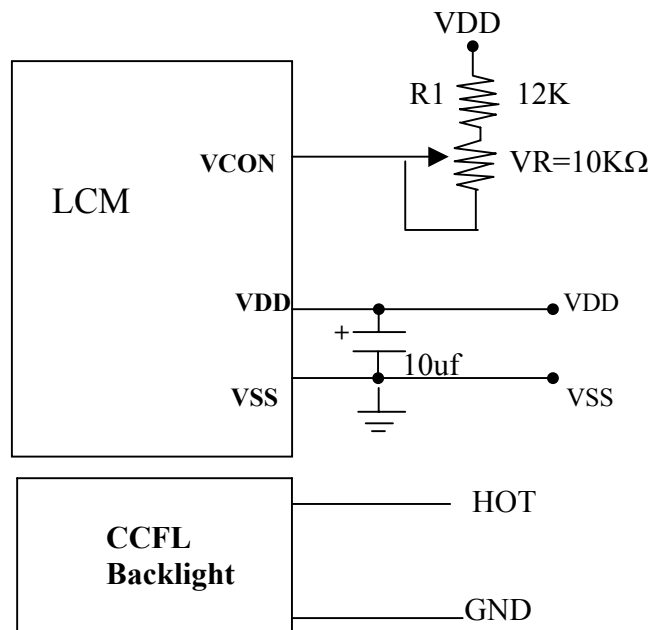

## 10. BLOCK DIAGRAM

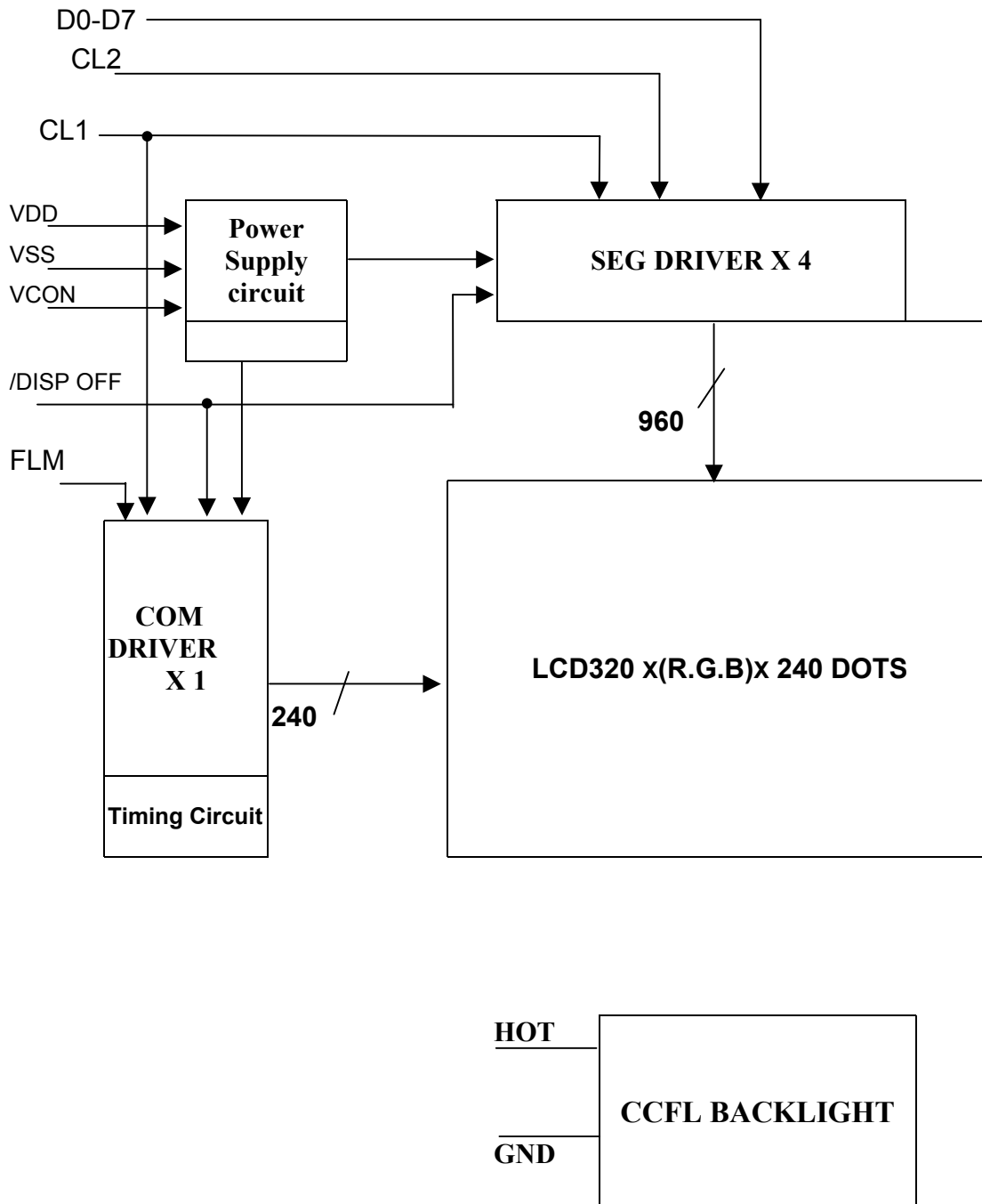

# 11. TOUCH PANEL CHARACTERISTICS

## 1. Mechanical Dimensions and Construction

1.1 General: Pen Mount Analog touch screen is laminated by ITO PET to ITO glass.

1.2 Construction:

Item	Description	Material	Remarks
1	ITO PET TOP layer circuit	0.188mm ITO PET Film	Antiglare coating Surface hardness:3H Resistance:500Ω/square±100Ω
2	ITO Patterned Glass	1.1mm ITO Glass	Resistance:400Ω/square±200Ω
3	Tail	0.188mm PET Film	Integral to Top layer circuit
4	Tail insulation	0.05mm	
5	Connector	Amp compatible	Pitch:2.54
6	Top layer silver bus	Silver ink	
7	Bottom Layer silver bus	Silver ink	
8	Silver bus contact layer	Silver ink	
9	Dot spacer	UV Cure ink	0.1 mm dia.
10	Contact layer	ITO/ITO	

## 1.3 Input Method Activation Force

Input Method	Activation Force
Stylus	<30 grams
Finger	<50 grams

## 2. Typical Optical Characteristics

2.1 Visible Light Transmission:>75%@550nm.

2.2 Haze:5%±2% through hard coated PET only

## 3. Electrical Specification

3.1 Operating Voltage 5.5V or less

3.2 Contact current 20mA(maximum)

3.3 Circuit close resistance X:600±200Ω

Y:400±150Ω

3.4 Circuit open resistance>20MΩ at 25VDC

3.5 Contact bounce<15ms

3.6 Linear Test Specification: Linearity Tolerance:1.5%max

## 4. Linearity

4.1 Linear Test Specification

Linearity Tolerance:1.5%max

4.2 Line Test Circuit for X Coordinate

Add 5 Voltage between Y1 and Y2 touch the point C0R0 to C9R9

Separately, and measure the voltage from X1 as the following drawing.

## 5. Environment Specification

5.1 Operating Temperature -10°C~ + 50 °C

Humidity less than 90 %RH

5.2 Storage Temperature -20°C~ + 70 °C

at Ambient Humidity

## 12. QUALITY ASSURANCE

### 12.1 Test Condition

#### 12.1.1 Temperature and Humidity(Ambient Temperature)

Temperature :  $20 \pm 5^{\circ}\text{C}$

Humidity :  $60 \pm 5\%$

#### 12.1.2 Operation

Unless specified otherwise, test will be conducted under function state.

#### 12.1.3 Container

Unless specified otherwise, vibration test will be conducted to the product itself without putting it in a container.

#### 12.1.4 Test Frequency

In case of related to deterioration such as shock test. It will be conducted only once.

#### 12.1.5 Test Method

No.	Parameter	Conditions	Regulations
1	High Temperature Operating	$50 \pm 2^{\circ}\text{C}$	Note 3
2	Low Temperature Operating	$0 \pm 2^{\circ}\text{C}$	Note 3
3	High Temperature Storage	$60 \pm 2^{\circ}\text{C}$	Note 3
4	Low Temperature Storage	$-20 \pm 2^{\circ}\text{C}$	Note 3
5	Vibration Test (Non-operation state)	Total fixed amplitude : 1.5mm Vibration Frequency : 10 ~ 55Hz One cycle 60 seconds to 3 directions of X.Y.Z. for each 15 minutes	Note 3
6	Damp Proof Test (Non-operation state)	$40^{\circ}\text{C} \pm 2^{\circ}\text{C}$ , 90~95%RH, 96h	Note 1,2
7	Shock Test (Non-operation state)	To be measured after dropping from 60cm high once concrete surface in packing state	Note 3

Note 1: Returned under normal temperature and humidity for 4 hrs.

Note 2: No dew condensation to be observed.

Note 3: No change on display and in operation under the test condition

## 12.2 Inspection condition

### 12.2.1 Inspection conditions

The LCD shall be inspected under 40W white fluorescent light.

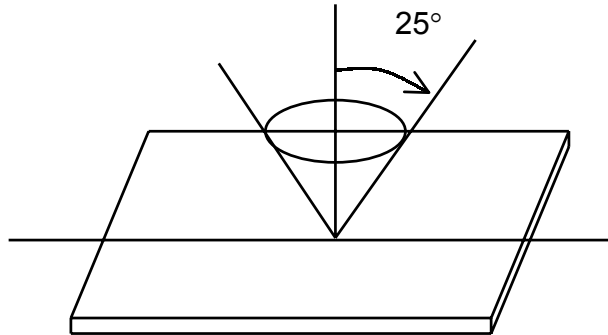

### 12.2.2 Definition of applicable Zones

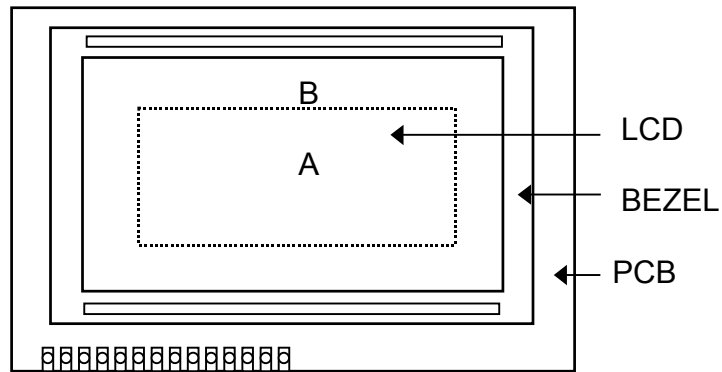

A : Display Area  
B : Non-Display Area



### 12.2.3 Inspection Parameters

No.	Parameter	Criteria																			
1	Black or White spots	<table border="1"> <thead> <tr> <th>Zone Dimension</th> <th>Acceptable number A</th> <th>Class Of Defects</th> <th>AQL Level</th> </tr> </thead> <tbody> <tr> <td><math>D \leq 0.25</math></td> <td>*</td> <td rowspan="5">Minor</td> <td rowspan="5">2.5</td> </tr> <tr> <td><math>0.25 &lt; D \leq 0.35</math></td> <td>10</td> </tr> <tr> <td><math>0.35 &lt; D \leq 0.5</math></td> <td>4</td> </tr> <tr> <td><math>0.5 &lt; D \leq 0.7</math></td> <td>3</td> </tr> <tr> <td><math>0.7 &lt; D</math></td> <td>0</td> </tr> </tbody> </table> <p><math>D = (\text{Long} + \text{Short}) / 2</math> * : Disregard</p>	Zone Dimension	Acceptable number A	Class Of Defects	AQL Level	$D \leq 0.25$	*	Minor	2.5	$0.25 < D \leq 0.35$	10	$0.35 < D \leq 0.5$	4	$0.5 < D \leq 0.7$	3	$0.7 < D$	0			
Zone Dimension	Acceptable number A	Class Of Defects	AQL Level																		
$D \leq 0.25$	*	Minor	2.5																		
$0.25 < D \leq 0.35$	10																				
$0.35 < D \leq 0.5$	4																				
$0.5 < D \leq 0.7$	3																				
$0.7 < D$	0																				
2	Scratch, Substances	<table border="1"> <thead> <tr> <th colspan="2">Zone L (mm) \ W(mm)</th> <th>Acceptable number A</th> <th>Class Of Defects</th> <th>AQL Level</th> </tr> </thead> <tbody> <tr> <td><math>L \leq 1.2</math></td> <td><math>W \leq 0.25</math></td> <td>2</td> <td rowspan="4">Minor</td> <td rowspan="4">2.5</td> </tr> <tr> <td><math>L \leq 1.5</math></td> <td><math>W \leq 0.2</math></td> <td>3</td> </tr> <tr> <td><math>L \leq 2.0</math></td> <td><math>W \leq 0.15</math></td> <td>3</td> </tr> <tr> <td><math>L \leq 3.0</math></td> <td><math>W \leq 0.1</math></td> <td>4</td> </tr> </tbody> </table> <p>L : Length W : Width * : Disregard Total defects should not exceed 4/module</p>	Zone L (mm) \ W(mm)		Acceptable number A	Class Of Defects	AQL Level	$L \leq 1.2$	$W \leq 0.25$	2	Minor	2.5	$L \leq 1.5$	$W \leq 0.2$	3	$L \leq 2.0$	$W \leq 0.15$	3	$L \leq 3.0$	$W \leq 0.1$	4
Zone L (mm) \ W(mm)		Acceptable number A	Class Of Defects	AQL Level																	
$L \leq 1.2$	$W \leq 0.25$	2	Minor	2.5																	
$L \leq 1.5$	$W \leq 0.2$	3																			
$L \leq 2.0$	$W \leq 0.15$	3																			
$L \leq 3.0$	$W \leq 0.1$	4																			
3	Air Bubbles (between glass & polarize )	<table border="1"> <thead> <tr> <th>Zone Dimension</th> <th>Acceptable number A</th> <th>Class of Defects</th> <th>AQL Level</th> </tr> </thead> <tbody> <tr> <td><math>D \leq 0.2</math></td> <td>*</td> <td rowspan="4">Minor</td> <td rowspan="4">2.5</td> </tr> <tr> <td><math>0.2 &lt; D \leq 0.3</math></td> <td>12</td> </tr> <tr> <td><math>0.3 &lt; D \leq 0.5</math></td> <td>3</td> </tr> <tr> <td><math>0.5 &lt; D</math></td> <td>0</td> </tr> </tbody> </table> <p>* : Disregard Total defects shall not excess 3/module.</p>	Zone Dimension	Acceptable number A	Class of Defects	AQL Level	$D \leq 0.2$	*	Minor	2.5	$0.2 < D \leq 0.3$	12	$0.3 < D \leq 0.5$	3	$0.5 < D$	0					
Zone Dimension	Acceptable number A	Class of Defects	AQL Level																		
$D \leq 0.2$	*	Minor	2.5																		
$0.2 < D \leq 0.3$	12																				
$0.3 < D \leq 0.5$	3																				
$0.5 < D$	0																				
4	Uniformity of Pixel	<p>(1) Pixel shape (with Dent)</p>																			

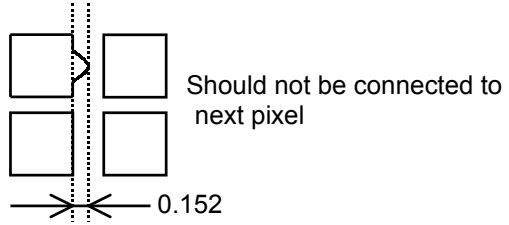
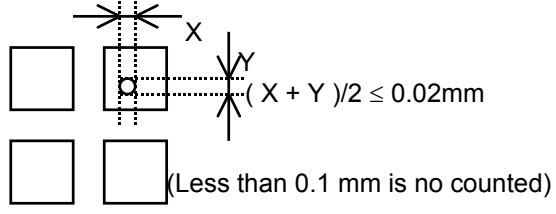
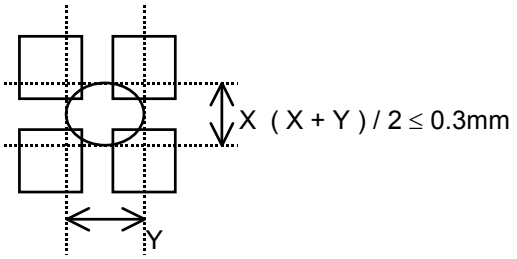
4	Uniformity of Pixel	(2) Pixel shape ( with Projection)	
			
		(3) Pin hole	
			
		(4) Deformation	
			
		Total acceptable number : 1/pixel, 5/cell	
Class of defects	<b>Major</b>	AQL 0.65%	<b>Definition</b>
		AQL 1.00%	It is a defect that is likely to result in failure or to reduce materially the usability of the product for the intended function.
	<b>Minor</b>	AQL 2.5%	It is a defect that is likely to assembly size and not result in functioning problem.
		It is a defect that will not result in functioning problem with deviation classified.	

### 12.3 Sampling Condition

Unless otherwise agree in written, the sampling inspection shall be applied to the incoming inspection of customer.

Lot size: Quantity of shipment lot per model.

Sampling type: normal inspection, single sampling

Inspection level: Level II

Sampling table: MIL-STD-105E

### 13. LOT NUMBERING SYSTEM

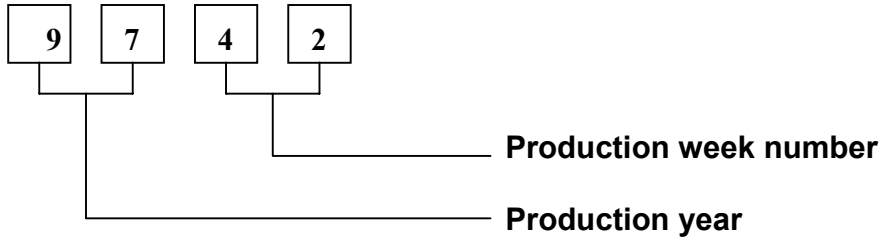

### 14. LCM NUMBERING SYSTEM

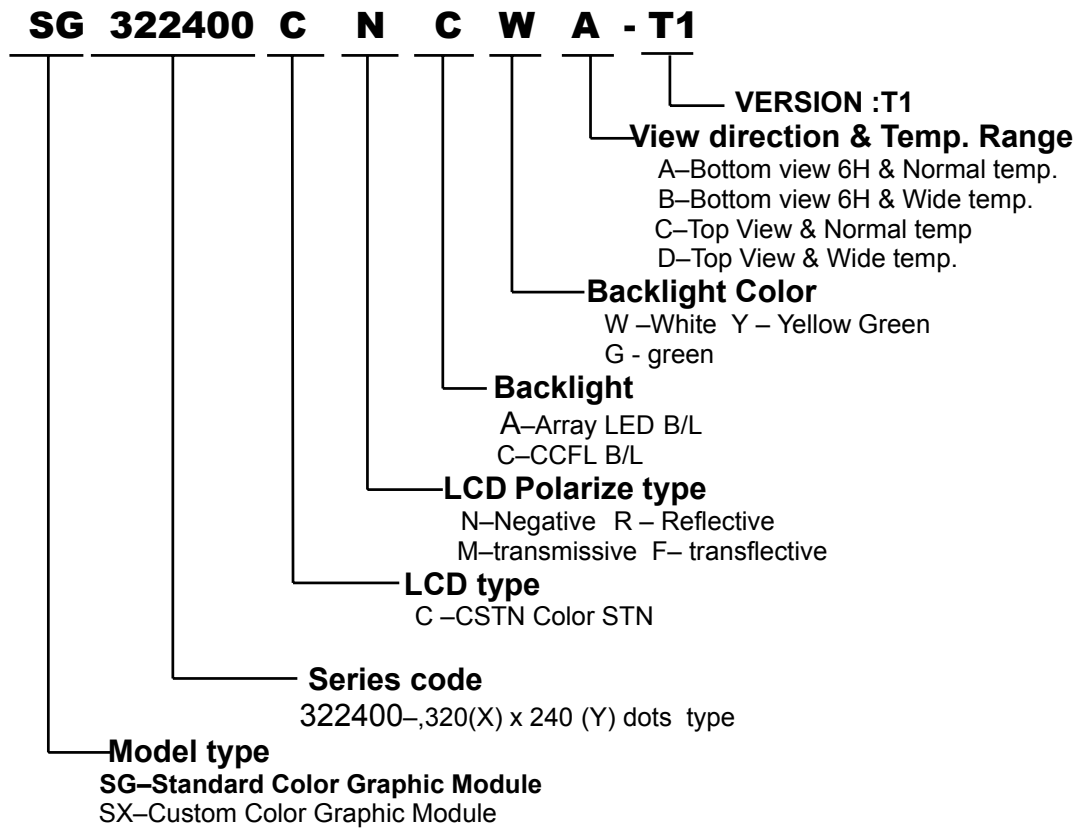

## 15. PRECAUTION FOR USING LCM

### 1. LIQUID CRYSTAL DISPLAY (LCD)

LCD is made up of glass, organic sealant, organic fluid, and polymer based polarizers. The following precautions should be taken when handling,

- (1). Keep the temperature within range of use and storage. Excessive temperature and humidity could cause polarization degradation, polarizer peel off or bubble.
- (2). Do not contact the exposed polarizers with anything harder than an HB pencil lead. To clean dust off the display surface, wipe gently with cotton, chamois or other soft material soaked in petroleum benzine.
- (3). Wipe off saliva or water drops immediately. Contact with water over a long period of time may cause polarizer deformation or color fading, while an active LCD with water condensation on its surface will cause corrosion of ITO electrodes.
- (4). Glass can be easily chipped or cracked from rough handling, especially at corners and edges.
- (5). Do not drive LCD with DC voltage.

### 2. Liquid Crystal Display Modules

#### 2.1 Mechanical Considerations

LCM are assembled and adjusted with a high degree of precision. Avoid excessive shocks and do not make any alterations or modifications. The following should be noted.

- (1). Do not tamper in any way with the tabs on the metal frame.
- (2). Do not modify the PCB by drilling extra holes, changing its outline, moving its components or modifying its pattern.
- (3). Do not touch the elastomer connector, especially insert an backlight panel (for example, EL).
- (4). When mounting a LCM make sure that the PCB is not under any stress such as bending or twisting. Elastomer contacts are very delicate and missing pixels could result from slight dislocation of any of the elements.
- (5). Avoid pressing on the metal bezel, otherwise the elastomer connector could be deformed and lose contact, resulting in missing pixels.

#### 2.2. Static Electricity

LCM contains CMOS LSI's and the same precaution for such devices should apply, namely

- (1). The operator should be grounded whenever he/she comes into contact with the module. Never touch any of the conductive parts such as the LSI pads, the copper leads on the PCB and the interface terminals with any parts of the human body.
- (2). The modules should be kept in antistatic bags or other containers resistant to static for storage.
- (3). Only properly grounded soldering irons should be used.
- (4). If an electric screwdriver is used, it should be well grounded and shielded from commutator sparks.

- (5) The normal static prevention measures should be observed for work clothes and working benches; for the latter conductive (rubber) mat is recommended.
- (6). Since dry air is inductive to statics, a relative humidity of 50-60% is recommended.

#### 2.3 Soldering

- (1). Solder only to the I/O terminals.
- (2). Use only soldering irons with proper grounding and no leakage.
- (3). Soldering temperature :  $280^{\circ}\text{C} \pm 10^{\circ}\text{C}$
- (4). Soldering time: 3 to 4 sec.
- (5). Use eutectic solder with resin flux fill.
- (6). If flux is used, the LCD surface should be covered to avoid flux spatters. Flux residue should be removed afterwards.

#### 2.4 Operation

- (1). The viewing angle can be adjusted by varying the LCD driving voltage  $V_0$ .
- (2). Driving voltage should be kept within specified range; excess voltage shortens display life.
- (3). Response time increases with decrease in temperature.
- (4). Display may turn black or dark blue at temperatures above its operational range; this is (however not pressing on the viewing area) may cause the segments to appear "fractured".
- (5). Mechanical disturbance during operation (such as pressing on the viewing area) may cause the segments to appear "fractured".

#### 2.5 Storage

If any fluid leaks out of a damaged glass cell, wash off any human part that comes into contact with soap and water. Never swallow the fluid. The toxicity is extremely low but caution should be exercised at all the time.

#### 2.6 Limited Warranty

Unless otherwise agreed between DATA IMAGE and customer, DATA IMAGE will replace or repair any of its LCD and LCM which is found to be defective electrically and visually when inspected in accordance with DATA IMAGE acceptance standards, for a period on one year from date of shipment. Confirmation of such date shall be based on freight documents. The warranty liability of DATA IMAGE is limited to repair and/or replacement on the terms set forth above. DATA IMAGE will not be responsible for any subsequent or consequential events.

# 16.OULINE DRAWING

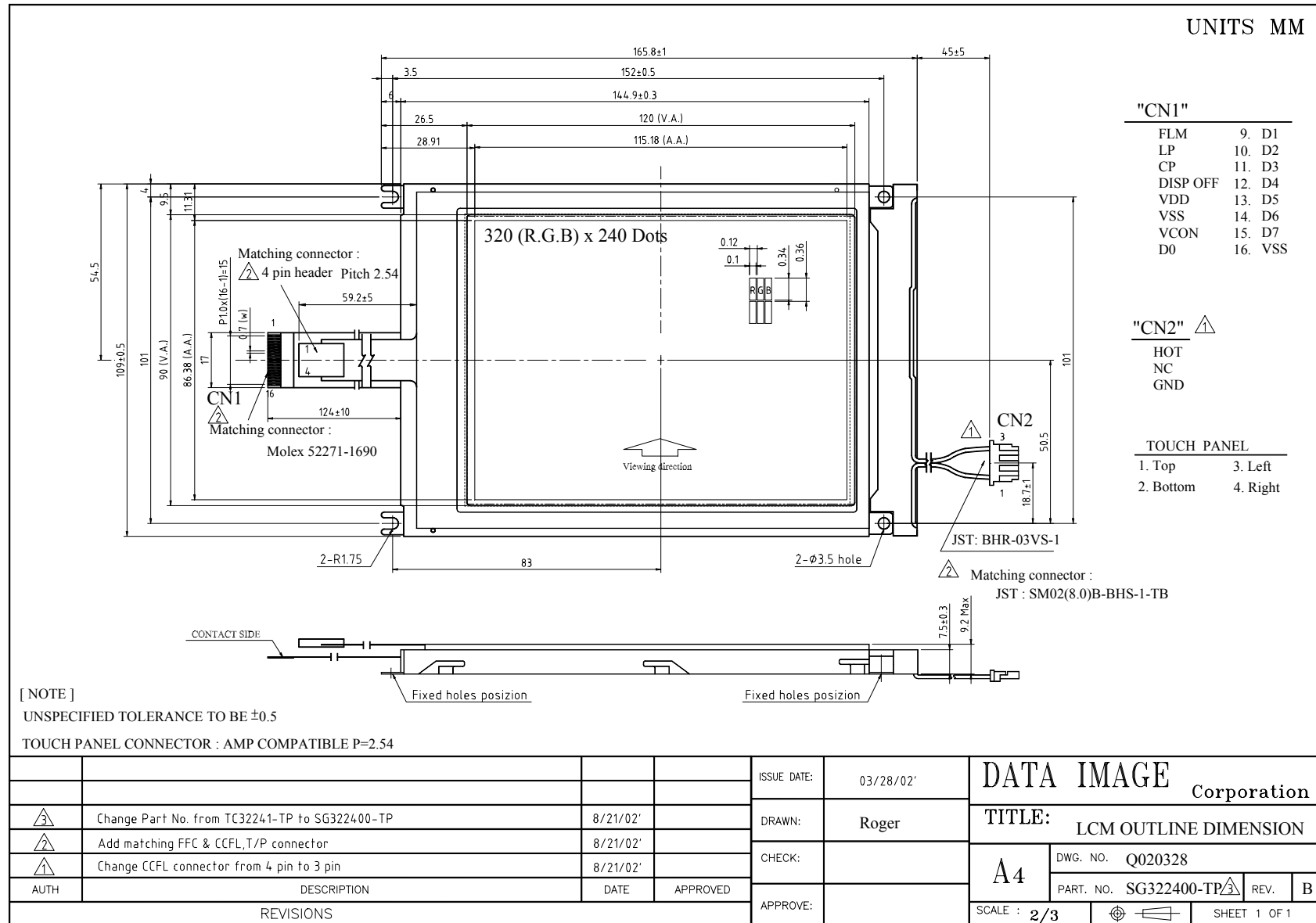

## 17. PACKAGE INFORMATION

