

# BCM4201 UNIVERSAL SATELLITE RECEIVER

## BCM4201 FEATURES

- The Broadcom BCM4201 is a universal QPSK receiver for DIRECTV®, DVB and Digicipher™ II digital satellite reception
- **Integrated satellite receiver**
  - 2-85 Mbps variable rate BPSK/OQPSK/QPSK receiver
  - Dual integrated 8-bit A/D converters
  - Dual square-root Nyquist matched filters ( $\alpha=0.2-0.35$ )
  - All digital clock and carrier recovery
  - Integrated PLLs
- **DVB/DIRECTV/Digicipher II-compliant FEC decoder**
  - 64-state Viterbi decoder supports rates = 5/11, 1/2, 3/5, 2/3, 3/4, 4/5, 5/6, 6/7, 7/8
  - Programmable convolutional deinterleaver, I=12 or 13 with internal RAM
  - Reed-Solomon decoder: (n,k) = (204,188) or (146,130): t=8
- **Seamless interface to BCM3440 CMOS satellite tuner or direct IF input**
- **I<sup>2</sup>C and SPI compatible microcontroller interface**
- **IEEE 1149.1 (JTAG) test interface**
- **80-pin PQFP pin package**
- **3.3 Volt operation**

## SUMMARY OF BENEFITS

- A universal digital transmission solution for DVB, DSS and Digicipher II systems
- An integrated solution enabling low complexity/low cost digital satellite IRDs
- Variable data rates support all satellite systems worldwide
- Integrated 8-bit A/D converters and PLL reduce system manufacturing costs
- Receives up to 85 Mbps for high-speed applications
- Operates down to 1 MBaud with excellent adjacent channel rejection characteristics due to 8-bit A/Ds for low-speed applications such as SCPC
- Specialized circuitry provided for cycle slip minimization
- On-chip BER tester to simplify system optimization

Satellite IRD Block Diagram

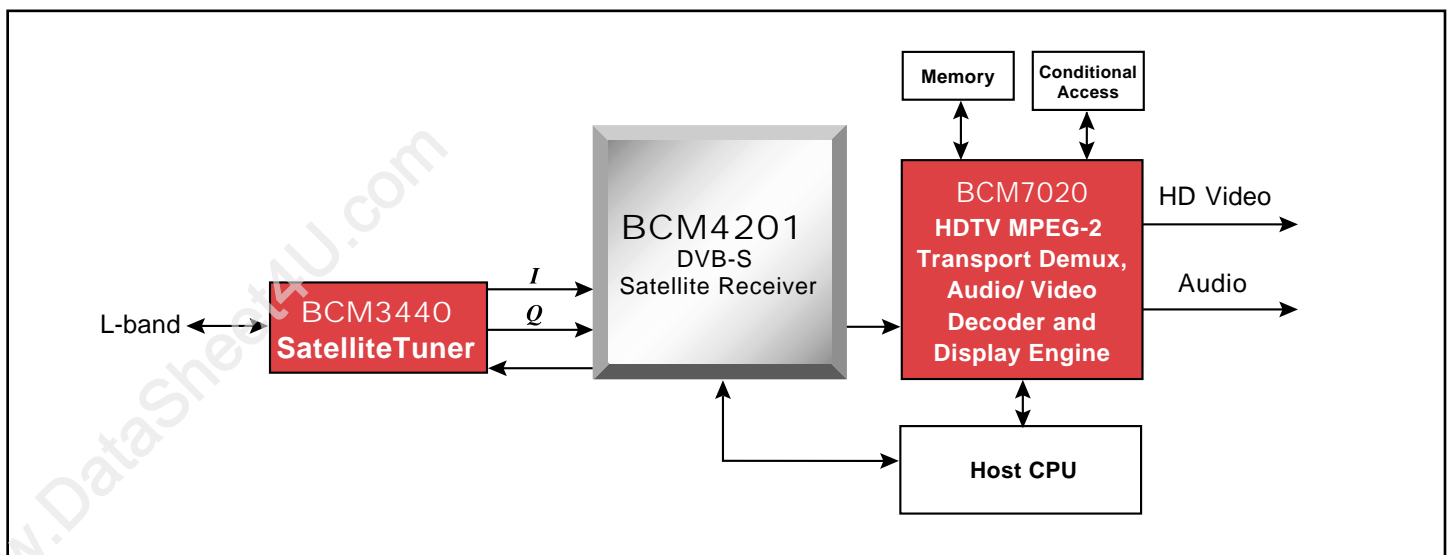

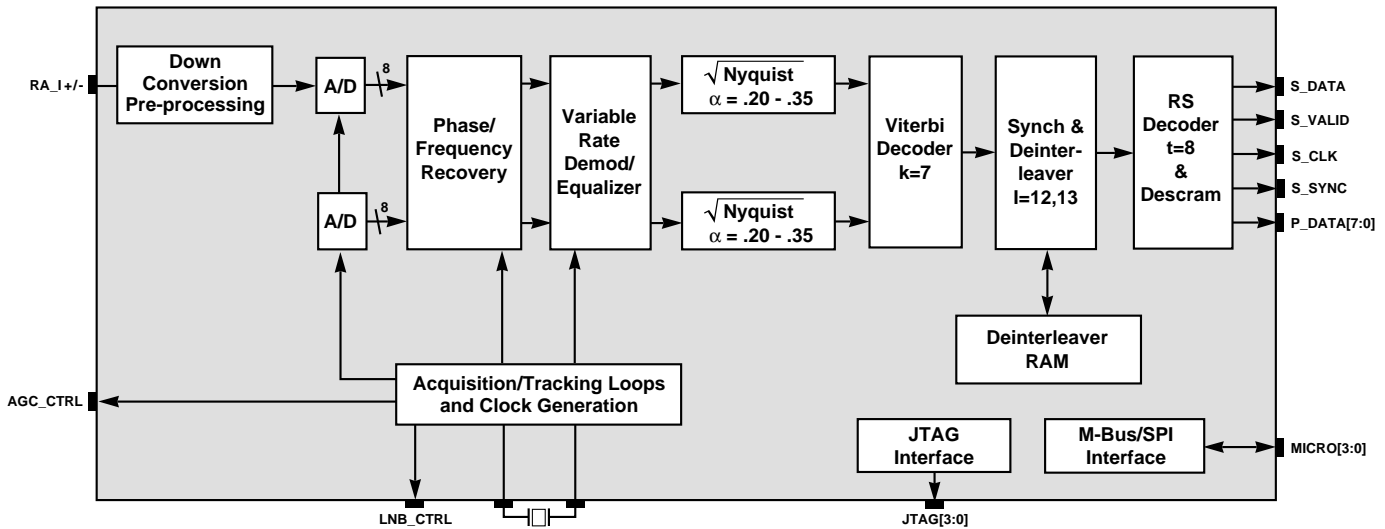

The **BCM4201** Universal Satellite Receiver is an integrated digital transmission solution for satellite Integrated Receiver Decoders (IRDs). Integrated features in the **BCM4201** include a 2-85 Mbps variable rate BPSK/QPSK/OQPSK receiver, dual 8-bit A/D converters, a phase/frequency recovery block, variable rate digital filters, square-root Nyquist matched filters, acquisition and tracking loops, and a DVB/DIRECTV®/Digicipher™ II compliant concatenated Viterbi/Reed-Solomon FEC decoder with deinterleaver. The receiver accepts an analog baseband or IF modulated (up to 480 MHz) signal, and transmits a demodulated error corrected output data stream. The **BCM4201** supports the DVB digital transmission standard for satellite broadcasting, that is in worldwide use today, the DIRECTV digital transmission standard and Digicipher II ITU-R 217/11 digital transmission standard.

Analog waveforms received by the **BCM4201** are sampled by the integrated A/D converters, digitally mixed to baseband, resampled, and filtered by dual square-root Nyquist filters. Optimized soft decisions are delivered to a programmable rate 64-state Viterbi decoder, frame synchronization block,

deinterleaver, t=8 Reed-Solomon FEC, and derandomizer. The final error-corrected output is delivered in MPEG-2 or DIRECTV transport stream format.

The **BCM4201** is a very flexible, cost-effective solution. It is compatible with DVB, DIRECTV and Digicipher II ITU-R 217/11 standards, enabling manufacturers to design the **BCM4201** into a single-standard IRD or a multi-standard IRD. The receiver supports variable bit rates up to 85 Mbps, which allows it to adapt to various satellite transponders in Europe, North America, and Asia. The **BCM4201** is capable of supporting low rate applications, down to 1 MBaud, for applications such as SCPC. The **BCM4201** is optimized for high-volume manufacturing. This level of integration in the **BCM4201** significantly reduces the cost and complexity of manufacturing IRDs.

The **BCM4201** contains an extremely accurate on-chip BER tester to simplify laboratory set-up and system optimization. Specialized circuitry has been implemented to virtually eliminate cycle slips.

Broadcom®, the pulse logo® and Connecting Everything™ are trademarks of Broadcom Corporation and/or its subsidiaries in the United States and certain other countries. Digicipher™ is a trademark of General Instrument (now Motorola). DIRECTV® is a registered trademark of DIRECTV, INC., a unit of Hughes Electronics Corporation. All other trademarks are the property of their respective owners.

Connecting  
everything™



BROADCOM CORPORATION  
16215 Alton Parkway, P.O. Box 57013  
Irvine, California 92619-7013

© 2002 by BROADCOM CORPORATION. All rights reserved.

4201.PB02-R-4.12.02

Phone: 949-450-8700  
FAX: 949-450-8710  
Email: info@broadcom.com  
Web: www.broadcom.com