

ZXTN2011Z

100V NPN LOW SATURATION MEDIUM POWER TRANSISTOR IN SOT89

SUMMARY

$BV_{CEO} = 100V$; $R_{SAT} = 31m\Omega$; $I_C = 4.5A$

DESCRIPTION

Packaged in the SOT89 outline this new low saturation 100V NPN transistor offers extremely low on state losses making it ideal for use in DC-DC circuits and various driving and power management functions.

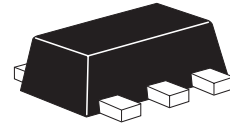

SOT89

FEATURES

- 4.5 amps continuous current
- Up to 10 amps peak current
- Very low saturation voltages

APPLICATIONS

- Motor driving
- Line switching
- High side switches
- Subscriber line interface cards (SLIC)

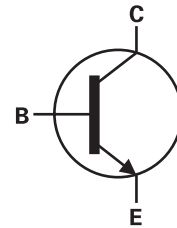

ORDERING INFORMATION

DEVICE	REEL SIZE	TAPE WIDTH	QUANTITY PER REEL
ZXTN2011ZTA	7"	12mm embossed	1,000 units

DEVICE MARKING

853

PINOUT

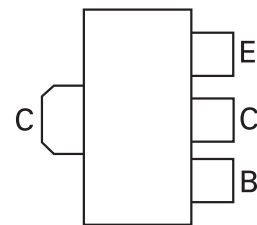

VIEW

ZXTN2011Z

ABSOLUTE MAXIMUM RATINGS

PARAMETER	SYMBOL	LIMIT	UNIT
Collector base voltage	BV_{CBO}	200	V
Collector emitter voltage	BV_{CEO}	100	V
Emitter base voltage	BV_{EBO}	7	V
Continuous collector current ^(a)	I_C	4.5	A
Peak pulse current	I_{CM}	10	A
Power dissipation at $T_A=25^\circ\text{C}$ ^(a)	P_D	1.5	W
Linear derating factor		12	mW/°C
Power dissipation at $T_A=25^\circ\text{C}$ ^(b)	P_D	2.1	W
Linear derating factor		16.8	mW/°C
Operating and storage temperature range	T_j, T_{stg}	-55 to +150	°C

THERMAL RESISTANCE

PARAMETER	SYMBOL	LIMIT	UNIT
Junction to ambient ^(a)	$R_{\theta JA}$	83	°C/W
Junction to ambient ^(b)	$R_{\theta JA}$	60	°C/W

NOTES:

(a) For a device surface mounted on 25mm x 25mm x 1.6mm FR4 PCB with high coverage of single sided 1oz copper, in still air conditions.

(b) For a device surface mounted on 50mm x 50mm x 1.6mm FR4 PCB with high coverage of single sided 1oz copper, in still air conditions.

ZXTN2011Z

CHARACTERISTICS

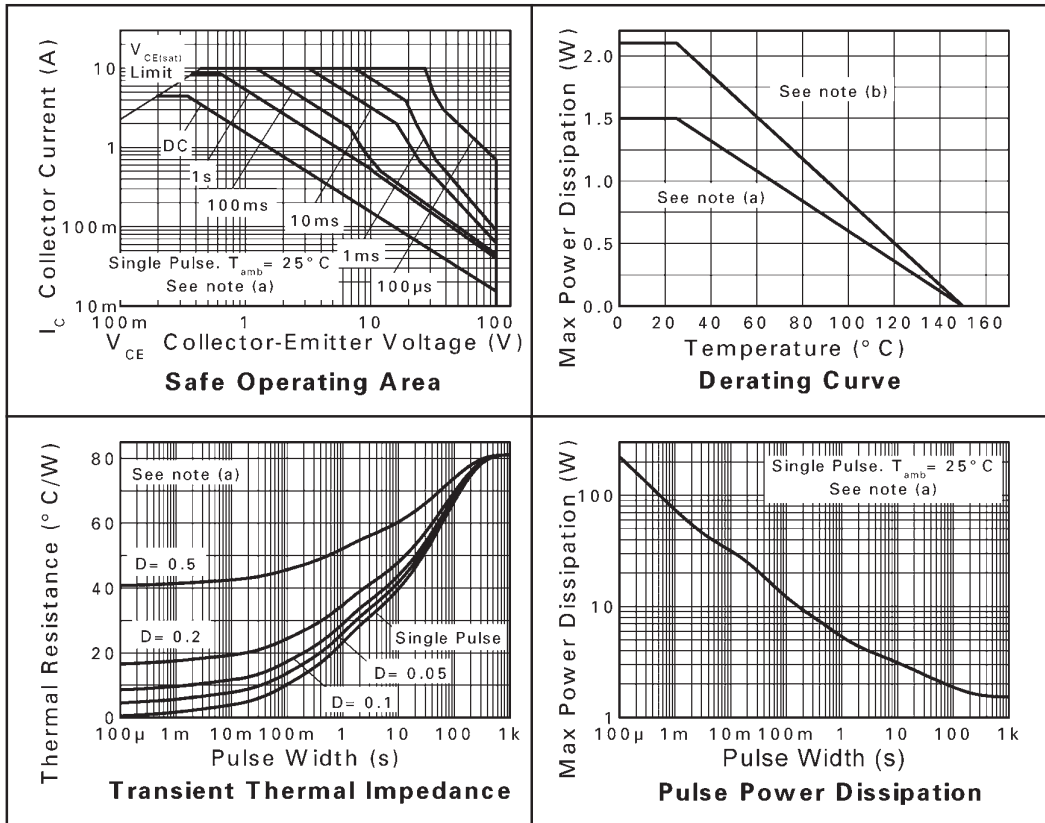

ZXTN2011Z

ELECTRICAL CHARACTERISTICS (at $T_{amb} = 25^{\circ}\text{C}$ unless otherwise stated)

PARAMETER	SYMBOL	MIN.	TYP.	MAX.	UNIT	CONDITIONS
Collector base breakdown voltage	BV_{CBO}	200	235		V	$I_C = 100\mu\text{A}$
Collector emitter breakdown voltage	BV_{CER}	200	235		V	$I_C = 1\mu\text{A}$, $R_B \leq 1\text{k}\Omega$
Collector emitter breakdown voltage	BV_{CEO}	100	115		V	$I_C = 10\text{mA}^*$
Emitter base breakdown voltage	BV_{EBO}	7	8.1		V	$I_E = 100\mu\text{A}$
Collector cut-off current	I_{CBO}			50 0.5	nA μA	$V_{CB} = 150\text{V}$ $V_{CB} = 150\text{V}$, $T_{amb} = 100^{\circ}\text{C}$
Collector cut-off current	I_{CER} $R \leq 1\text{k}\Omega$			100 0.5	nA μA	$V_{CB} = 150\text{V}$ $V_{CB} = 150\text{V}$, $T_{amb} = 100^{\circ}\text{C}$
Emitter cut-off current	I_{EBO}			10	nA	$V_{EB} = 6\text{V}$
Collector-emitter saturation voltage	$V_{CE(SAT)}$		20 45 85 155	30 60 115 195	mV	$I_C = 0.1\text{A}$, $I_B = 5\text{mA}^*$ $I_C = 1\text{A}$, $I_B = 100\text{mA}^*$ $I_C = 2\text{A}$, $I_B = 100\text{mA}^*$ $I_C = 5\text{A}$, $I_B = 500\text{mA}^*$
Base emitter saturation voltage	$V_{BE(SAT)}$		1000	1100	mV	$I_C = 5\text{A}$, $I_B = 500\text{mA}^*$
Base emitter turn on voltage	$V_{BE(ON)}$		900	1000	mV	$I_C = 5\text{A}$, $V_{CE} = 2\text{V}^*$
Static forward current transfer ratio	h_{FE}	100 100 30 10	230 200 60 20	300		$I_C = 10\text{mA}$, $V_{CE} = 2\text{V}^*$ $I_C = 2\text{A}$, $V_{CE} = 2\text{V}^*$ $I_C = 5\text{A}$, $V_{CE} = 2\text{V}^*$ $I_C = 10\text{A}$, $V_{CE} = 2\text{V}^*$
Transition frequency	f_T		130		MHz	$I_C = 100\text{mA}$, $V_{CE} = 10\text{V}$ $f = 50\text{MHz}$
Output capacitance	C_{OBO}		26		pF	$V_{CB} = 10\text{V}$, $f = 1\text{MHz}^*$
Switching times	t_{ON} t_{OFF}		41 1010		ns	$I_C = 1\text{A}$, $V_{CC} = 10\text{V}$, $I_{B1} = I_{B2} = 100\text{mA}$

* Measured under pulsed conditions. Pulse width $\leq 300\mu\text{s}$; duty cycle $\leq 2\%$.

ZXTN2011Z

TYPICAL CHARACTERISTICS

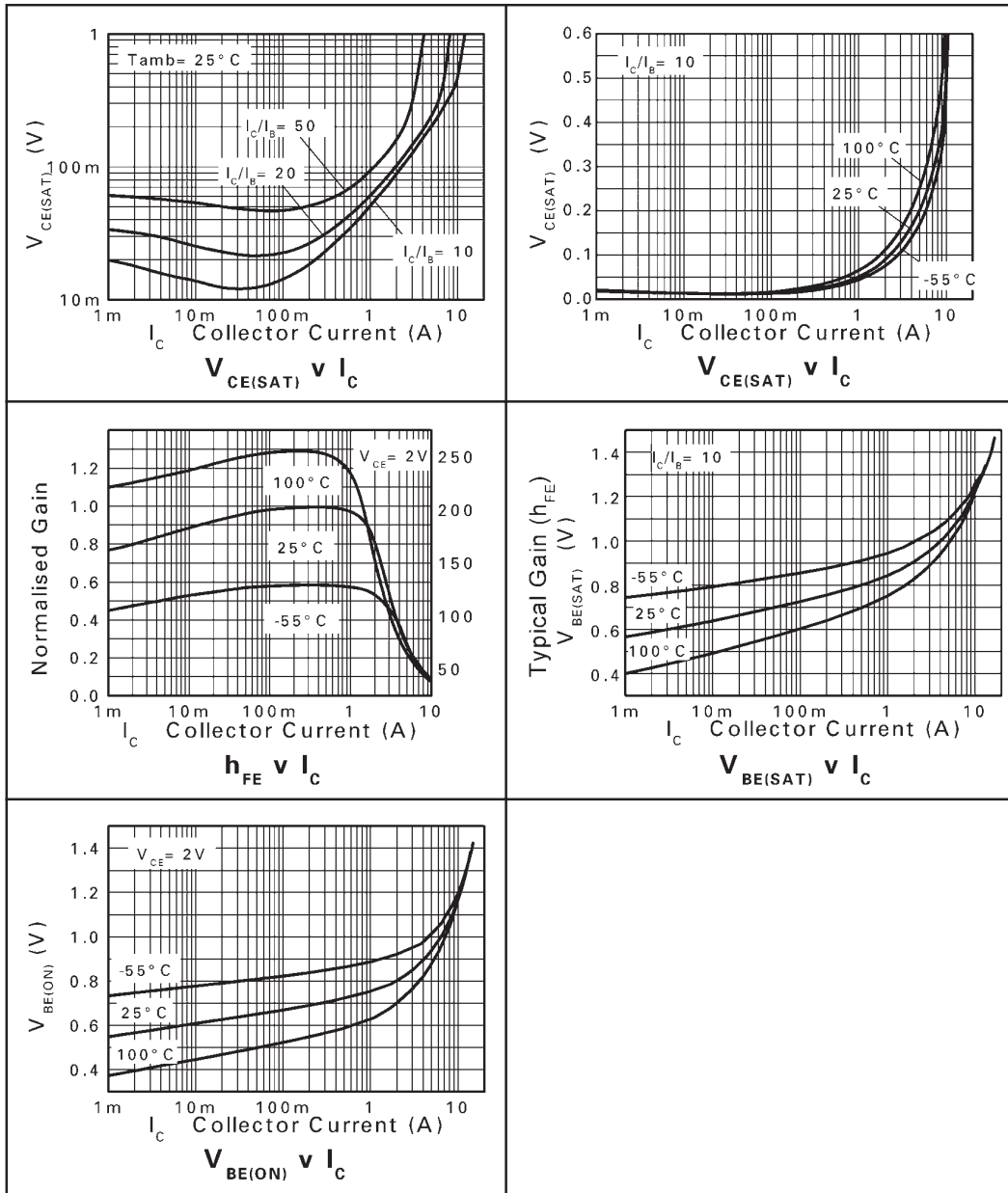

ZXTN2011Z

PACKAGE OUTLINE

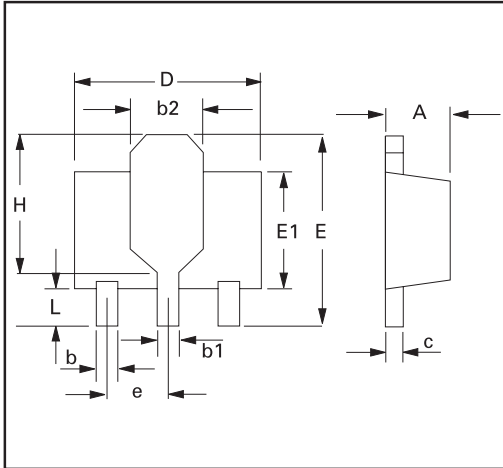

PACKAGE DIMENSIONS

DIM	Millimeters		Inches		DIM	Millimeters		Inches	
	Min	Max	Min	Max		Min	Max	Min	Max
A	1.40	1.60	0.550	0.630	e	1.40	1.50	0.055	0.059
b	0.38	0.48	0.015	0.019	E	3.75	4.25	0.150	0.167
b1	-	0.53	-	0.021	E1	-	2.60	-	0.102
b2	1.50	1.80	0.060	0.071	G	2.90	3.00	0.114	0.118
c	0.28	0.44	0.011	0.017	H	2.60	2.85	0.102	0.112
D	4.40	4.60	0.173	0.181	-	-	-	-	-

© Zetex Semiconductors plc 2005

Europe	Americas	Asia Pacific	Corporate Headquarters
Zetex GmbH Streitfeldstraße 19 D-81673 München Germany	Zetex Inc 700 Veterans Memorial Hwy Hauppauge, NY 11788 USA	Zetex (Asia) Ltd 3701-04 Metroplaza Tower 1 Hing Fong Road, Kwai Fong Hong Kong	Zetex Semiconductors plc Zetex Technology Park Chadderton, Oldham, OL9 9LL United Kingdom
Telefon: (49) 89 45 49 49 0 Fax: (49) 89 45 49 49 49 europa.sales@zetex.com	Telephone: (1) 631 360 2222 Fax: (1) 631 360 8222 usa.sales@zetex.com	Telephone: (852) 26100 611 Fax: (852) 24250 494 asia.sales@zetex.com	Telephone (44) 161 622 4444 Fax: (44) 161 622 4446 hq@zetex.com

These offices are supported by agents and distributors in major countries world-wide.

This publication is issued to provide outline information only which (unless agreed by the Company in writing) may not be used, applied or reproduced for any purpose or form part of any order or contract or be regarded as a representation relating to the products or services concerned. The Company reserves the right to alter without notice the specification, design, price or conditions of supply of any product or service.

For the latest product information, log on to www.zetex.com



ISSUE 2 - MAY 2006