

## 3V MICROPOWER QUAD VOLTAGE COMPARATORS

- DEDICATED TO **3.3V OR BATTERY SUPPLY**  
(specified at 3V and 5V)
- EXTREMELY LOW SUPPLY CURRENT :  
**9 $\mu$ A typ/comparator**
- WIDE SINGLE SUPPLY RANGE  
**2.7V to 16V**
- EXTREMELY LOW INPUT CURRENTS :  
**1pA TYP**
- INPUT COMMON-MODE VOLTAGE RANGE  
INCLUDES GND
- FAST RESPONSE TIME : 2.5 $\mu$ s typ for  
5mV overdrive
- PIN-TO-PIN AND FUNCTIONALLY  
COMPATIBLE WITH BIPOLAR LM339

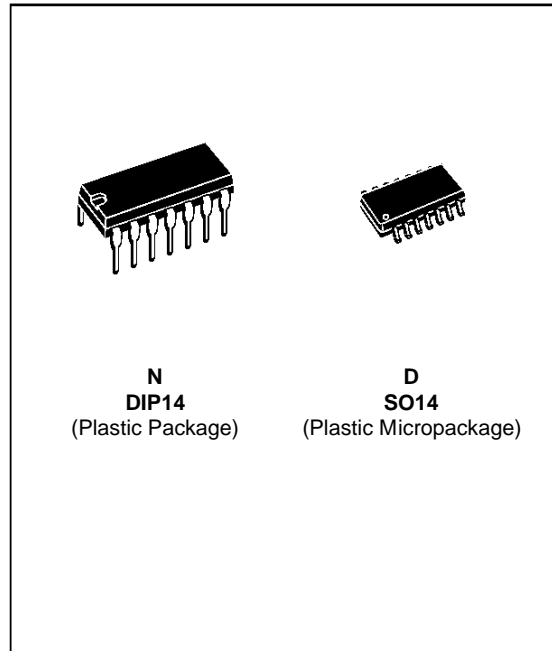

### DESCRIPTION

The TS3V339 is a micropower quad CMOS voltage comparator with extremely low consumption of 9 $\mu$ A typ / comparator (20 times less than bipolar LM339). Similar performances are offered by the quad micropower comparator TS3V3704 with a push-pull CMOS output.

Thus response times remain similar to the LM339.

### ORDER CODES

Part Number	Temperature Range	Package	
		N	D
TS3V339I	-40°C, +125°C	●	●

### PIN CONNECTIONS (top view)

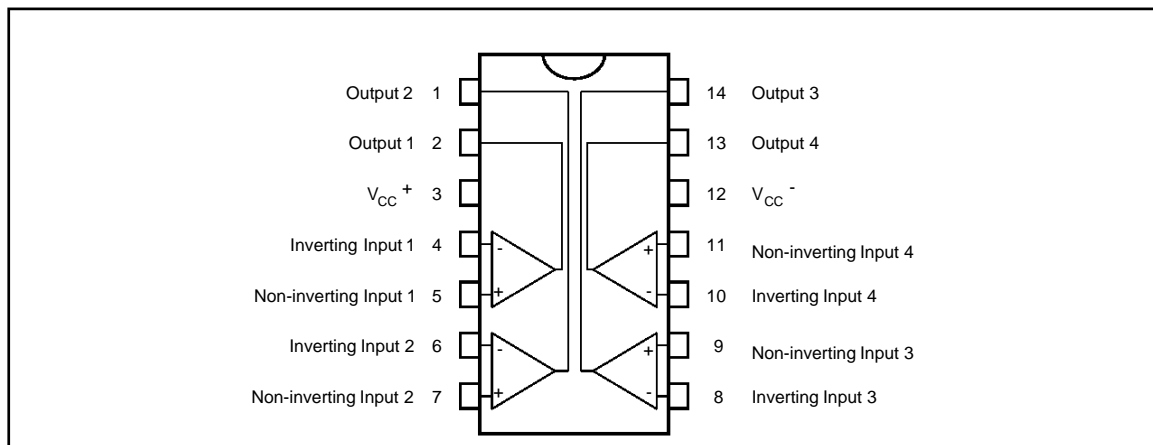

SCHEMATIC DIAGRAM (for 1/4 TS3V339)

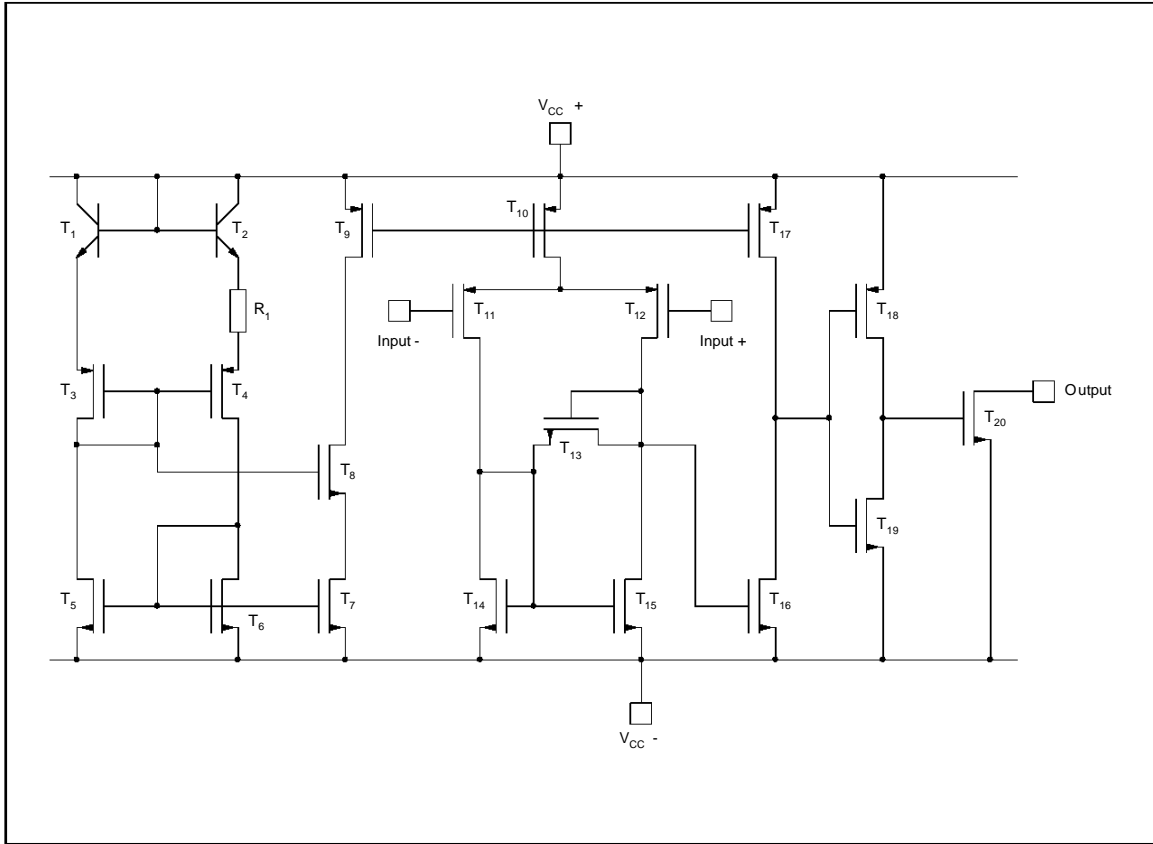

MAXIMUM RATINGS

Symbol	Parameter	Value	Unit
$V_{CC}^+$	Supply Voltage - (note 1)	18	V
$V_{id}$	Differential Input Voltage - (note 2)	$\pm 18$	V
$V_i$	Input Voltage - (note 3)	18	V
$V_O$	Output Voltage	18	V
$I_O$	Output Current	20	mA
$T_{oper}$	Operating Free-Air Temperature Range	-40 to +125	$^{\circ}C$
	TS3V339I		
$T_{stg}$	Storage Temperature Range	-65 to +150	$^{\circ}C$

- Notes :
1. All voltage values, except differential voltage, are with respect to network ground terminal.
  2. Differential voltages are the non-inverting input terminal with respect to the inverting input terminal.
  3. The magnitude of the input and the output voltages must never exceed the magnitude of the positive supply voltage.
  4. Short circuit from outputs to  $V_{CC}^+$  can cause excessive heating and eventual destruction.

OPERATING CONDITIONS

Symbol	Parameter	Value	Unit
$V_{CC}^+$	Supply Voltage	2.7 to 16	V
$V_{icm}$	Common Mode Input Voltage Range	0 to $V_{CC}^+ - 1.5$	V

**ELECTRICAL CHARACTERISTICS**
 $V_{CC}^+ = 3V$ ,  $V_{CC}^- = 0V$ ,  $T_{amb} = 25^\circ C$  (unless otherwise specified)

Symbol	Parameter	Min.	Typ.	Max.	Unit
$V_{io}$	Input Offset Voltage - (note 1) $V_{ic} = 1.5V$ $T_{min.} \leq T_{amb} \leq T_{max.}$			5 6.5	mV
$I_{io}$	Input Offset Current - (note 2) $V_{ic} = 1.5V$ $T_{min.} \leq T_{amb} \leq T_{max.}$		1	300	pA
$I_{ib}$	Input Bias Current - (note 2) $V_{ic} = 1.5V$ $T_{min.} \leq T_{amb} \leq T_{max.}$		1	600	pA
$V_{icm}$	Input Common Mode Voltage Range $T_{min.} \leq T_{amb} \leq T_{max.}$	0 to $V_{CC}^+ - 1.2$ 0 to $V_{CC}^+ - 1.5$			V
CMR	Common-mode Rejection Ratio $V_{ic} = V_{icm \text{ min.}}$		70		dB
SVR	Supply Voltage Rejection Ratio $V_{CC}^+ = 3V$ to $5V$		70		dB
$I_{OH}$	High Level Output Current $V_{id} = +1V$ , $V_{OH} = 3V$ $T_{min.} \leq T_{amb} \leq T_{max.}$		2	40 1000	nA
$V_{OL}$	Low Level Output Voltage $V_{id} = +1V$ , $I_{OL} = +6mA$ $T_{min.} \leq T_{amb} \leq T_{max.}$		400	550 800	mV
$I_{CC}$	Supply Current (each comparator) No load - Outputs low $T_{min.} \leq T_{amb} \leq T_{max.}$		9	20 25	$\mu A$
$t_{PLH}$	Response Time Low to High $V_{ic} = 0V$ , $f = 10kHz$ , $R_L = 5.1k\Omega$ , $C_L = 15pF$ , Overdrive = 5mV TTL Input		1.5 0.7		$\mu s$
$t_{PHL}$	Response Time High to Low $V_{ic} = 0V$ , $f = 10kHz$ , $R_L = 5.1k\Omega$ , $C_L = 15pF$ , Overdrive = 5mV TTL Input		2.5 0.08		$\mu s$

**Note :** 1. The specified offset voltage is the maximum value required to drive the output up to 4.5V or down to 0.3V.  
2. Maximum values including unavoidable inaccuracies of the industrial test.

**ELECTRICAL CHARACTERISTICS**

$V_{CC}^+ = 5V$ ,  $V_{CC}^- = 0V$ ,  $T_{amb} = 25^{\circ}C$  (unless otherwise specified)

Symbol	Parameter	Min.	Typ.	Max.	Unit
$V_{io}$	Input Offset Voltage - (note 1) $V_{ic} = 2.5V$ $T_{min.} \leq T_{amb} \leq T_{max.}$		1.4	5 6.5	mV
$I_{io}$	Input Offset Current - (note 2) $V_{ic} = 2.5V$ $T_{min.} \leq T_{amb} \leq T_{max.}$		1	300	pA
$I_{ib}$	Input Bias Current - (note 2) $V_{ic} = 2.5V$ $T_{min.} \leq T_{amb} \leq T_{max.}$		1	600	pA
$V_{icm}$	Input Common Mode Voltage Range $T_{min.} \leq T_{amb} \leq T_{max.}$	0 to $V_{CC}^+ - 1.2$ 0 to $V_{CC}^+ - 1.5$			V
CMR	Common-mode Rejection Ratio $V_{ic} = V_{icm\ min.}$		70		dB
SVR	Supply Voltage Rejection Ratio $V_{CC}^+ = +5V$ to $+10V$		80		dB
$I_{OH}$	High Level Output Current $V_{id} = 1V$ , $V_{OH} = +5V$ $T_{min.} \leq T_{amb} \leq T_{max.}$		2	40 1000	nA
$V_{OL}$	Low Level Output Voltage $V_{id} = -1V$ , $I_{OL} = 6mA$ $T_{min.} \leq T_{amb} \leq T_{max.}$		260	400 650	mV
$I_{CC}$	Supply Current (each comparator) No load - Outputs low $T_{min.} \leq T_{amb} \leq T_{max.}$		10	20 25	$\mu A$
$t_{PLH}$	Response Time Low to High $V_{ic} = 0V$ , $f = 10kHz$ , $R_L = 5.1k\Omega$ , $C_L = 15pF$ , Overdrive = 5mV TTL Input		1.5 0.7		$\mu s$
$t_{PHL}$	Response Time High to Low $V_{ic} = 0V$ , $f = 10kHz$ , $R_L = 5.1k\Omega$ , $C_L = 15pF$ , Overdrive = 5mV TTL Input		2.5 0.08		$\mu s$

**Note :** 1. The specified offset voltage is the maximum value required to drive the output up to 4.5V or down to 0.3V.  
2. Maximum values including unavoidable inaccuracies of the industrial test.

**PACKAGE MECHANICAL DATA**  
14 PINS - PLASTIC DIP

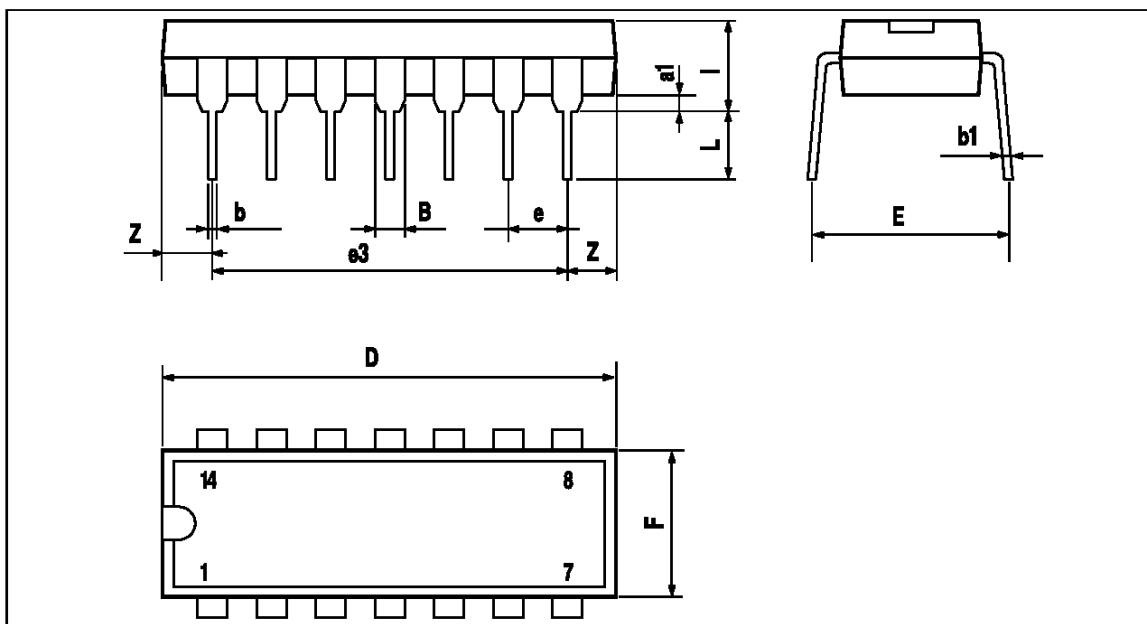

Dim.	Millimeters			Inches		
	Min.	Typ.	Max.	Min.	Typ.	Max.
a1	0.51			0.020		
B	1.39		1.65	0.055		0.065
b		0.5			0.020	
b1		0.25			0.010	
D			20			0.787
E		8.5			0.335	
e		2.54			0.100	
e3		15.24			0.600	
F			7.1			0.280
i			5.1			0.201
L		3.3			0.130	
Z	1.27		2.54	0.050		0.100

**PACKAGE MECHANICAL DATA**  
14 PINS - PLASTIC MICROPACKAGE (SO)

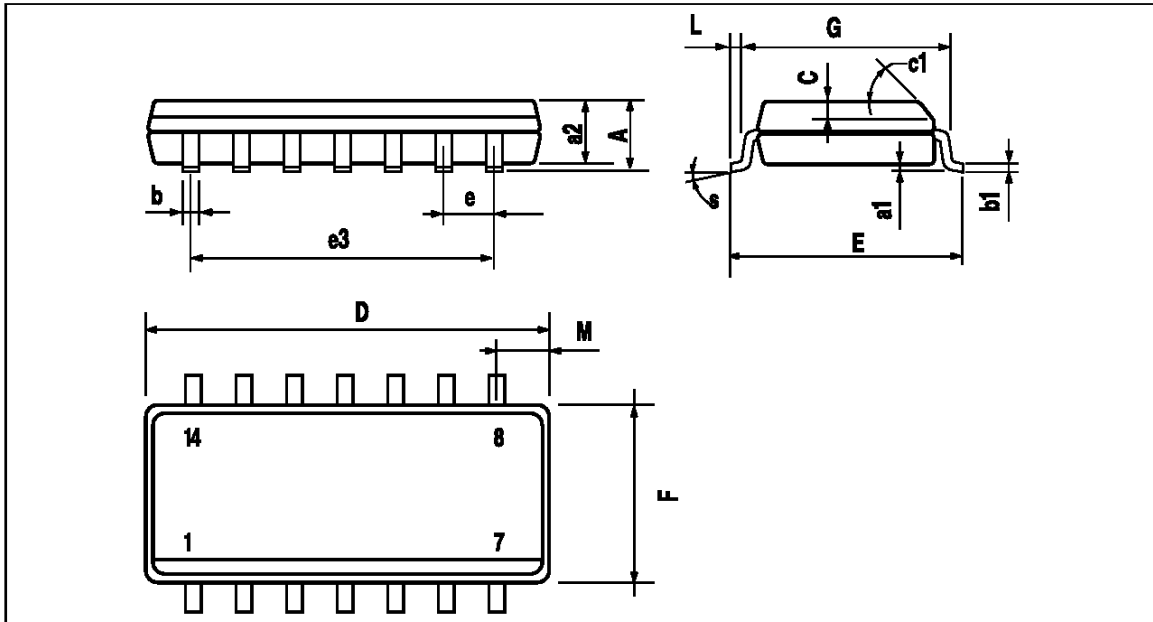

PM-SO14.EPS

Dim.	Millimeters			Inches		
	Min.	Typ.	Max.	Min.	Typ.	Max.
A			1.75			0.069
a1	0.1		0.2	0.004		0.008
a2			1.6			0.063
b	0.35		0.46	0.014		0.018
b1	0.19		0.25	0.007		0.010
C		0.5			0.020	
c1	45° (typ.)					
D	8.55		8.75	0.336		0.334
E	5.8		6.2	0.228		0.244
e		1.27			0.050	
e3		7.62			0.300	
F	3.8		4.0	0.150		0.157
G	4.6		5.3	0.181		0.208
L	0.5		1.27	0.020		0.050
M			0.68			0.027
S	8° (max.)					

SO14.TBL

Information furnished is believed to be accurate and reliable. However, SGS-THOMSON Microelectronics assumes no responsibility for the consequences of use of such information nor for any infringement of patents or other rights of third parties which may result from its use. No license is granted by implication or otherwise under any patent or patent rights of SGS-THOMSON Microelectronics. Specifications mentioned in this publication are subject to change without notice. This publication supersedes and replaces all information previously supplied. SGS-THOMSON Microelectronics products are not authorized for use as critical components in life support devices or systems without express written approval of SGS-THOMSON Microelectronics.

© 1997 SGS-THOMSON Microelectronics – Printed in Italy – All Rights Reserved

SGS-THOMSON Microelectronics GROUP OF COMPANIES

Australia - Brazil - Canada - China - France - Germany - Hong Kong - Italy - Japan - Korea - Malaysia - Malta - Morocco  
The Netherlands - Singapore - Spain - Sweden - Switzerland - Taiwan - Thailand - United Kingdom - U.S.A.

ORDER CODE :