



# 4-BIT PARALLEL ACCESS SHIFT REGISTER

The functional characteristics of the MC74F195 4-Bit Parallel Access Shift Register are indicated in the Logic Diagram and Function Table. The device is useful in a wide variety of shifting, counting, and storage applications. It performs serial, parallel, serial-to-parallel, or parallel-to-serial data transfers at very high speeds.

The MC74F195 operates in two primary modes, shift right ( $Q_0$ - $Q_1$ ) and parallel load, which are controlled by the state of the Parallel Enable ( $\overline{PE}$ ) input. Serial data enters the first flip-flop ( $Q_0$ ) via the J and  $\overline{K}$  inputs when the  $\overline{PE}$  input is HIGH, and is shifted 1 bit in the direction  $Q_0$ - $Q_1$ - $Q_2$ - $Q_3$  following each LOW-to-HIGH clock transition. The J and  $\overline{K}$  inputs provide the flexibility of the JK type input is made for special applications, and by tying the two pins together the simple D-type input is made for general applications. The device appears as four common clocked D flip-flops when the  $\overline{PE}$  input is LOW. After the LOW-to-HIGH clock transition, data on the parallel inputs ( $D_0$ - $D_3$ ) is transferred to the respective  $Q_0$ - $Q_3$  outputs. Shift left operation ( $Q_3$ - $Q_2$ ) can be achieved by tying the  $Q_n$  outputs to the  $D_{n-1}$  inputs and holding the  $\overline{PE}$  input LOW.

All parallel and serial data transfers are synchronous, occurring after each LOW-to-HIGH clock transition. The MC74F195 utilizes edge-triggering; therefore, there is no restriction on the activity of the J,  $\overline{K}$ ,  $D_n$ , and  $\overline{PE}$  inputs for logic operation, other than the setup and hold time requirements.

A LOW on the asynchronous Master Reset ( $\overline{MR}$ ) input sets all Q outputs LOW, independent of any other input condition.

- Shift Right and Parallel Load Capability
- J- $\overline{K}$  (D-Type) Inputs to First Stage
- Complement Output from Last Stage
- Asynchronous Master Reset

### CONNECTION DIAGRAM DIP

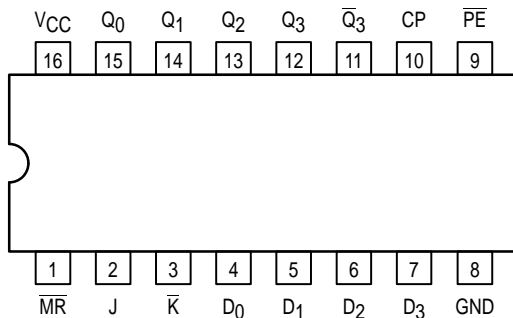

## MC74F195

### 4-BIT PARALLEL ACCESS SHIFT REGISTER FAST™ SCHOTTKY TTL

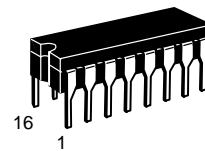

**J SUFFIX**  
CERAMIC  
CASE 620-09

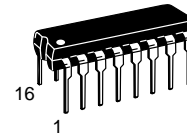

**N SUFFIX**  
PLASTIC  
CASE 648-08

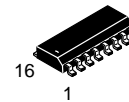

**D SUFFIX**  
SOIC  
CASE 751B-03

### ORDERING INFORMATION

MC74FXXXJ	Ceramic
MC74FXXXN	Plastic
MC74FXXXD	SOIC

### LOGIC SYMBOL

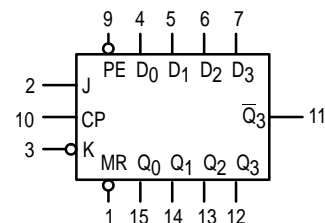

$V_{CC}$  = PIN 16  
GND = PIN 8

# MC74F195

## GUARANTEED OPERATING RANGES

Symbol	Parameter		Min	Typ	Max	Unit
V <sub>CC</sub>	Supply Voltage	74	4.5	5.0	5.5	V
T <sub>A</sub>	Operating Ambient Temperature Range	74	0	25	70	°C
I <sub>OH</sub>	Output Current — High	74			-1.0	mA
I <sub>OL</sub>	Output Current — Low	74			20	mA

## LOGIC DIAGRAM

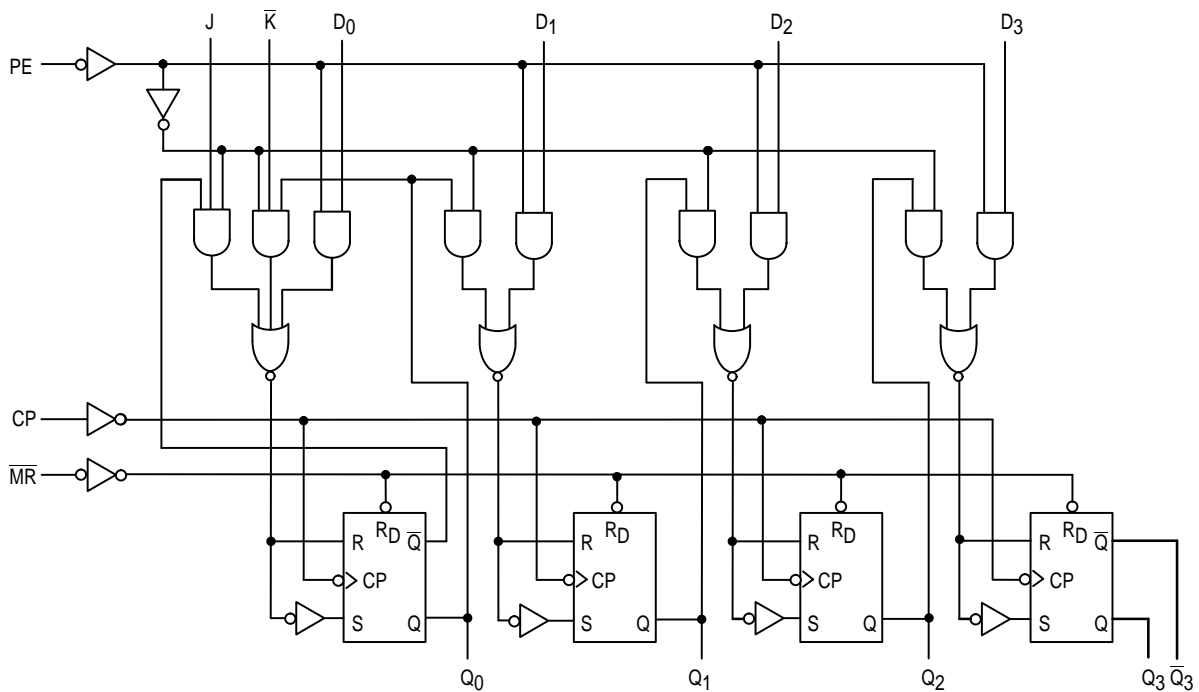

## FUNCTION TABLE

Operating Modes	Inputs						Outputs				
	$\overline{MR}$	CP	$\overline{PE}$	J	$\overline{K}$	D <sub>n</sub>	Q <sub>0</sub>	Q <sub>1</sub>	Q <sub>2</sub>	Q <sub>3</sub>	$\overline{Q}_3$
Asynchronous Reset	L	X	X	X	X	X	L	L	L	L	H
Shift, Set First Stage	H	↑	h	h	h	X	H	q <sub>0</sub>	q <sub>1</sub>	q <sub>2</sub>	$\overline{q}_2$
Shift, Reset First Stage	H	↑	h	l	l	X	L	q <sub>0</sub>	q <sub>1</sub>	q <sub>2</sub>	$\overline{q}_2$
Shift, Toggle First Stage	H	↑	h	h	l	X	$\overline{q}_0$	q <sub>0</sub>	q <sub>1</sub>	q <sub>2</sub>	$\overline{q}_2$
Shift, Retain First Stage	H	↑	h	l	h	X	q <sub>0</sub>	q <sub>0</sub>	q <sub>1</sub>	q <sub>2</sub>	$\overline{q}_2$
Parallel Load	H	↑	l	X	X	d <sub>n</sub>	d <sub>0</sub>	d <sub>1</sub>	d <sub>2</sub>	d <sub>3</sub>	$\overline{d}_3$

H = HIGH Voltage Level

L = LOW Voltage Level

X = Don't Care

d<sub>n</sub> (q<sub>n</sub>) = Lower case letters indicate the state of the referenced input (or output) one setup time prior to the LOW-to-HIGH clock transition.

↑ = LOW-to-HIGH clock transition

# MC74F195

## DC CHARACTERISTICS OVER OPERATING TEMPERATURE RANGE (unless otherwise specified)

Symbol	Parameter	Limits			Unit	Test Conditions	
		Min	Typ	Max			
V <sub>IH</sub>	Input HIGH Voltage	2.0			V	Guaranteed Input HIGH Voltage	
V <sub>IL</sub>	Input LOW Voltage			0.8	V	Guaranteed Input LOW Voltage	
V <sub>IK</sub>	Input Clamp Diode Voltage			-1.2	V	I <sub>IN</sub> = -18 mA	V <sub>CC</sub> = MIN
V <sub>OH</sub>	Output HIGH Voltage	74	2.5		V	I <sub>OH</sub> = -1.0 mA	V <sub>CC</sub> = 4.5 V
		74	2.7		V		V <sub>CC</sub> = 4.75 V
V <sub>OL</sub>	Output LOW Voltage			0.5	V	I <sub>OL</sub> = 20 mA	V <sub>CC</sub> = 4.5 V
I <sub>IH</sub>	Input HIGH Current			20	μA	V <sub>IN</sub> = 2.7 V	V <sub>CC</sub> = MAX
				100		V <sub>IN</sub> = 7.0 V	
I <sub>IL</sub>	Input LOW Current			-0.6	mA	V <sub>CC</sub> = MAX	
I <sub>OS</sub>	Output Short Circuit Current (Note 2)	-60		-150	mA	V <sub>OUT</sub> = 0 V	V <sub>CC</sub> = MAX
I <sub>CC</sub>	Power Supply Current			38	mA	V <sub>CC</sub> = MAX	

### NOTES:

- For conditions shown as MIN or MAX, use the appropriate value specified under guaranteed operating ranges.
- Not more than one output should be shorted at a time, nor for more than 1 second.

## AC CHARACTERISTICS

Symbol	Parameter	54/74F		74F		Unit
		T <sub>A</sub> = +25°C V <sub>CC</sub> = +5.0 V C <sub>L</sub> = 50 pF		T <sub>A</sub> = 0°C to +70°C V <sub>CC</sub> = 5.0 V ± 10% C <sub>L</sub> = 50 pF		
		Min	Max	Min	Max	
f <sub>max</sub>		105		90		MHz
t <sub>PLH</sub>	Propagation Delay	2.5	7.0	2.5	8.0	ns
t <sub>PHL</sub>	CP to Q/Q̄	2.5	8.0	2.5	9.0	
t <sub>PHL</sub>	Propagation Delay, MR̄ to Q	3.0	10	3.0	11	ns
t <sub>PLH</sub>	Propagation Delay, MR̄ to Q̄	3.0	10.5	3.0	11	ns

# MC74F195

## AC OPERATING REQUIREMENTS

Symbol	Parameter	74F		74F		Unit
		T <sub>A</sub> = + 25°C V <sub>CC</sub> = + 5.0 V C <sub>L</sub> = 50 pF		T <sub>A</sub> = 0°C to + 70°C V <sub>CC</sub> = 5.0 V ± 10% C <sub>L</sub> = 50 pF		
		Min	Max	Min	Max	
t <sub>S</sub> (H)	Setup Time, HIGH or LOW J, K, D to CP	4.0		4.0		ns
t <sub>S</sub> (L)		4.0		4.0		
t <sub>H</sub> (H)	Hold Time, HIGH or LOW J, K, D to CP	0		1.0		ns
t <sub>H</sub> (L)		0		1.0		
t <sub>S</sub> (H)	Setup Time, HIGH or LOW $\overline{PE}$ to CP	8.0		9.0		ns
t <sub>S</sub> (L)		8.0		9.0		
t <sub>H</sub> (H)	Hold Time, HIGH or LOW $\overline{PE}$ to CP	0		0		ns
t <sub>H</sub> (L)		0		0		
t <sub>w</sub> (H)	CP Pulse Width, HIGH	5.0		5.5		ns
t <sub>w</sub> (L)	$\overline{MR}$ Pulse Width, LOW	5.0		5.0		ns
t <sub>rec</sub>	Recovery Time, $\overline{MR}$ to CP	7.0		8.0		ns