

Digital Attenuator, 3 Bit, Single Control

28 dB, 0.5 - 2 GHz



Features

- Single Control CMOS Logic for each bit
- Positive Supply +3 to +5 Volts
- Low Cost SOIC-8 Plastic Package
- Tape and Reel Packaging Available

Description

M/A-COM's AT-242 is a 3 bit, 4 dB step GaAs MMIC digital attenuator in a low cost SOIC 8-lead surface mount plastic package. The AT-242 is ideally suited for use where high accuracy, very low power consumption and low intermodulation products are required. Typical applications include radio, cellular, wireless LANs, GPS equipment and automatic gain/level control circuits.

The AT-242 is fabricated with a GaAs MMIC using a mature 1-micron process. The process features full chip passivation for increased performance and reliability.

SOIC-8¹

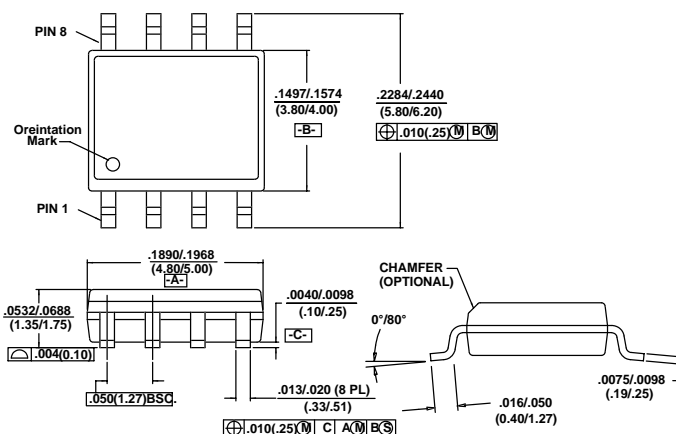

1. Dimensions are in inches/mm.

Absolute Maximum Ratings¹

Parameter	Absolute Maximum
Maximum Input Power	
50 MHz	+27 dBm
500 - 2000 MHz	+34 dBm
Supply Voltage	-1V, +8V
Control Voltage	-1V, V _{supply} +0.5V
Operating Temperature	-40°C to +85°C
Storage Temperature	-65°C to +150°C

1. Exceeding any one or a combination of these limits may cause permanent damage.

Ordering Information

Part Number	Package
AT-242	SOIC-8 Lead Plastic
AT-242TR	Forward Tape and Reel ¹

1. If specific reel size is required, consult factory for part number assignment.

Electrical Specifications: T_A = +25°C^{1,2}

Parameter	Test Conditions	Units	Min.	Typ.	Max.
Reference Insertion Loss	0.5 - 1.0 GHz	dB		1.4	1.6
	0.5 - 2.0 GHz	dB		1.7	1.9
Attenuation Accuracy	0.5 - 1.0 GHz	± (0.15 dB +3% of Attenuation Setting in dB)	dB		
	0.5 - 2.0 GHz	± (0.3 dB +8% of Attenuation Setting in dB)	dB		
VSWR	0.5 - 1.0 GHz			1.3:1	±0.8
	0.5 - 2.0 GHz			1.6:1	±1.5
P _{1dB}	Input Power (V _s = +5V) 900 MHz	dBm		25	
T _{rise} , T _{fall}	10% to 90% RF, 90% to 10% RF	μS		290	
T _{on} , T _{off}	50% Control to 90% RF, Control to 10% RF	μS		300	
Transients	In-band	mV		260	
IP ₂	Measured Relative to Input Power ²	dBm		75	
IP ₃	Measured Relative to Input Power ²	dBm		45	

1. All measurements at 1 GHz 5Vdc in a 50Ω system unless otherwise specified. The RF ports must be blocked out side of the package from ground or any other voltage. Insertion Loss varies at 0.003 dB/°C.
2. For two-tone input power up to +10 dBm

V2.00

Truth Table

V1	V2	V3	Attenuation (dB)
1	1	1	Reference I.L.
1	0	1	4
1	1	0	8
1	0	0	12
0	1	1	16
0	0	1	20
0	1	0	24
0	0	0	28

Logic 1 = $V_s \pm 0.2$ V
 Logic 0 = 0 ± 0.2 C

Functional Schematic^{1, 2, 3}

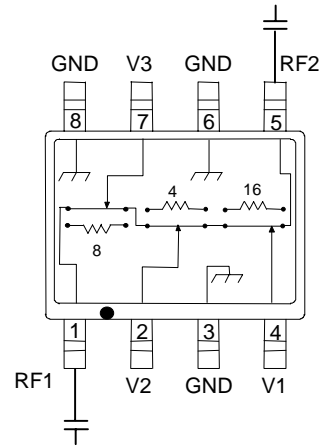

1. $V_s = -3 V_{DC} - 5 V_{DC} @ 50 \mu A$ max.
2. V_s can be applied to RF1 or RF2 through a 10K Ω pull-up resistor.
3. External DC blocking capacitors are required on all RF ports.
4. 39 pF used for data measurement.

Typical Performance Curves

