

CURRENT MODE PWM CONTROLLER

The KA3882/3/4/5 are fixed PWM controller for Off-Line and DC to DC converter applications. The internal circuits include UVLO, low start up current circuit, temperature compensated reference, high gain error amplifier, current sensing comparator, and high current totempole output for driving a POWER MOSFET. Also KA 3882/3/4/5 provide low start up current below 0.3mA and short shutdown delay time typ. 100ns.

The KA3882 and KA3884 have UVLO threshold of 1.6V(on) and 10V(off).

The KA3883 and KA3885 are 8.4V(on) and 7.6V(off).

The KA3882 and KA3883 can operate within 100% duty cycle.

The KA3884 and KA3885 within 50% by using T Flip-Flop.

FEATURES

- Low Start Current 0.2mA (typ)
- Operating Range Up To 500KHz
- Cycle by Cycle Current Limiting
- Under Voltage Lock Out With Hysteresis
- Short Shutdown Delay Time: typ.100ns
- High Current Totempole Output
- Output Swing Limiting: 22V

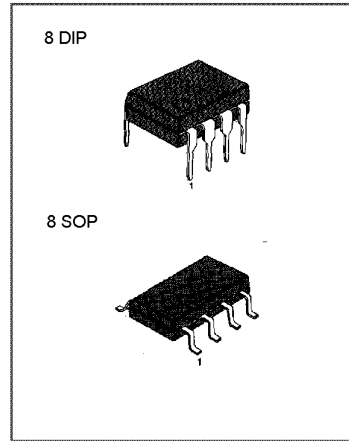

ORDERING INFORMATION

Device	Package	Operating Temperature
KA388X	8 DIP	0 ~ + 85°C
KA388XD	8 SOP	0 ~ + 85°C

BLOCK DIAGRAM

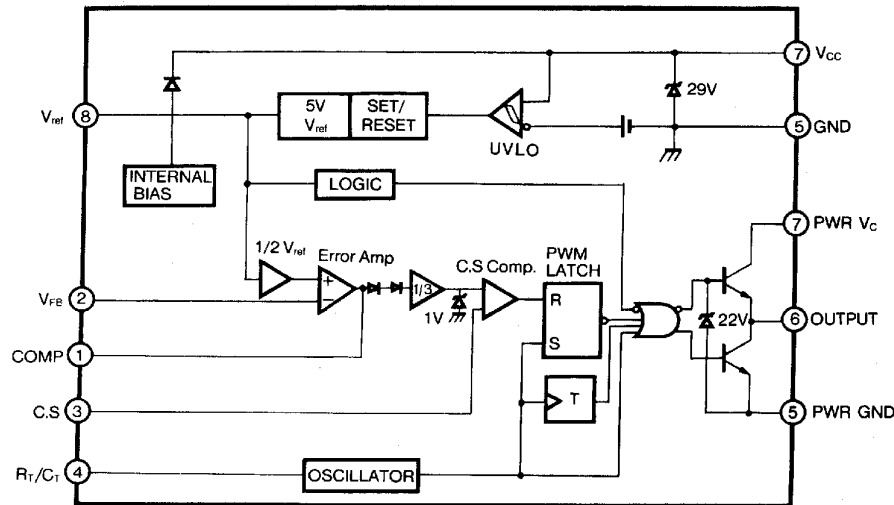

ABSOLUTE MAXIMUM RATINGS

Characteristic	Symbol	Value	Unit
Supply Voltage	V_{CC}	30	V
Output Current	I_O	+ 1	A
Analog Inputs (pin 2, 3)	$V_{I(ANA)}$	- 0.3 to 6.3	V
Error Amp. Output Sink Current	$I_{SINK(EA)}$	10	mA
Power Dissipation	P_D	1	W

ELECTRICAL CHARACTERISTICS

 ($V_{CC} = 15V$, $R_T = 10K\Omega$, $C_T = 3.3nF$, $T_A = 0^\circ C$ to $+ 85^\circ C$, Unless otherwise specified)

Characteristic	Symbol	Test Conditions	Min	Typ	Max	Unit
REFERENCE SECTION						
Output Voltage	V_{REF}	$T_J = 25^\circ C$, $I_O = 1mA$	4.9	5.0	5.1	V
Line Regulation	ΔV_{REF}	$V_{CC} = 12V$ to $25V$	—	6	20	mV
Load Regulation	ΔV_{REF}	$I_O = 1mA$ to $20mA$	—	6	25	mV
Output Short Circuit	I_{SC}	$T_a = 25^\circ C$	—	- 100	- 180	mA
OSILLATOR SECTION						
Initial Accuracy	F_{OSC}	$T_J = 25^\circ C$	47	52	57	KHz
Voltage Stability	ST_V	$V_{CC} = 12V$ to $25V$	—	0.2	1	%
Amplitude	V_{OSC}	V_{PIN4} , Peak to Peak	—	1.7	—	V
Discharge Current	I_{DISCHG}	$T_J = 25^\circ C$, $Pin4 = 2V$	7.8	8.3	8.8	mA
CURRENT SENSE SECTION						
Gain	G_V	(NOTE 2, 3)	2.85	3	3.15	V/V
Maximum Input Signal	$V_{I(MAX)}$	$V_{PIN1} = 5V$ (NOTE 2)	0.9	1.0	1.1	V
PSRR	PSRR	$V_{CC} = 12V$ to $25V$ (NOTE 1, 2)	—	70	—	dB
Input Bias Current	I_{BIAS}	—	—	- 2	-10	μA
Delay to Output	T_D	$V_{PIN3} = 0V$ to $2V$ (NOTE1)	—	100	200	ns

ELECTRICAL CHARACTERISTICS(Continued)

 ($V_{CC} = 15V$, $R_T = 10K\Omega$, $C_T = 3.3nF$, $T_A = 0^\circ C$ to $+85^\circ C$, Unless otherwise specified)

Characteristic	Symbol	Test Conditions	Min	Typ	Max	Unit
ERROR AMPLIFIER SECTION						
Input Voltage	V_I	$T_{PIN1} = 2.5V$	2.42	2.50	2.58	V
Input Bias Current	I_{BIAS}	—	—	-0.3	-2	μA
Open Loop Gain	G_{VO}	$V_O = 2V$ to $4V$ (NOTE 1)	65	90	—	dB
Unity Gain Bandwidth	GBW	$T_J = 25^\circ C$ (NOTE 1)	0.7	1	—	MHz
PSRR	PSRR	$V_{CC} = 12V$ to $25V$ (NOTE 1)	60	70	—	dB
Output Sink Current	I_{SINK}	$V_{PIN2} = 2.7V$ $V_{PIN1} = 1.1V$	2	6	—	mA
Output Source Current	I_{SOURCE}	$V_{PIN2} = 2.3V$ $V_{PIN1} = 5.0V$	-0.5	-0.8	—	mA
Output High Voltage	V_{OH}	$V_{PIN2} = 2.3V$ $R1 = 15K\Omega$ to GND	5	6	—	V
Output Low Voltage	V_{OL}	$V_{PIN2} = 2.7V$ $R1 = 15K\Omega$ to Pin8	—	0.8	1.1	V
OUTPUT SECTION						
Output Low Level	V_{OL}	$I_{SINK} = 20mA$	—	0.1	0.4	V
		$I_{SINK} = 200mA$	—	1.5	2.2	V
Output High Level	V_{OH}	$I_{SOURCE} = 20mA$	13	13.5	—	V
		$I_{SOURCE} = 200mA$	12	13.5	—	V
Rise Time	t_R	$T_J = 25^\circ C$, $C1 = 1nF$ (NOTE 1)	—	40	100	ns
Fall Time	t_F	$T_J = 25^\circ C$, $C1 = 1nF$ (NOTE 1)	—	40	100	ns
Output Voltage Swing Limit	V_{OLIM}	$V_{CC} = 27V$, $C1 = 1nF$	—	22	—	V
UNDER VOLTAGE LOCKOUT SECTION						
Start Threshold	V_{TH}	KA3882/4	15	16	17	V
		KA3883/5	7.8	8.4	9.0	V
Min.Operating Voltage (After turn on)	V_{TL}	KA3882/4	9	10	11	V
		KA3883/5	7.0	7.6	8.2	V

ELECTRICAL CHARACTERISTICS(Continued)

 ($V_{CC} = 15V$, $R_T = 10K\Omega$, $C_T = 3.3nF$, $T_A = 0^\circ C$ to $+85^\circ C$, unless otherwise specified)

Characteristic	Symbol	Test Conditions	Min	Typ	Max	Unit
PWM SECTION						
Maximum Duty Cycle	D_{MAX}	KA3882/3	94	96	100	%
		KA3884/5	47	48	50	%
Minimum Duty Cycle	D_{MIN}	—	—	—	0	%
TOTAL STANDBY CURRENT						
Start-Up Current	I_{ST}	—	—	0.2	0.4	mA
Operating Supply Current	I_{CC}	$V_{PIN2} = V_{PIN3} = 0V$	—	11	17	mA
V_{CC} Zener Voltage	V_Z	$I_{CC} = 25mA$	—	29	—	V

 * Adjust V_{CC} above the start threshold before setting at 15V

NOTE 1. These parameters, although guaranteed, are not 100% tested in production.

 2. Parameter measured at trip point of latch with $V_2 = 0V$.

 3. Gain defined as: $G_V = \Delta V_{PIN1} / \Delta V_{PIN3}$ ($V_{PIN3} = 0$ to $0.8V$)

Dimensions in Millimeters

