

74AUP2G04

Low-power dual inverter

Rev. 01. — 16 January 2006

Preliminary data sheet

1. General description

The 74AUP2G04 is a high-performance, low-power, low-voltage, Si-gate CMOS device, superior to most advanced CMOS compatible TTL families.

Schmitt-trigger action at all inputs makes the circuit tolerant to slower input rise and fall times across the entire V_{CC} range from 0.8 V to 3.6 V.

This device ensures a very low static and dynamic power consumption across the entire V_{CC} range from 0.8 V to 3.6 V.

This device is fully specified for partial Power-down applications using I_{OFF} . The I_{OFF} circuitry disables the output, preventing the damaging backflow current through the device when it is powered down.

The 74AUP2G04 provides two inverting buffers.

2. Features

- Wide supply voltage range from 0.8 V to 3.6 V
- High noise immunity
- Complies with JEDEC standards:
 - ◆ JESD8-12 (0.8 V to 1.3 V)
 - ◆ JESD8-11 (0.9 V to 1.65 V)
 - ◆ JESD8-7 (1.2 V to 1.95 V)
 - ◆ JESD8-5 (1.8 V to 2.7 V)
 - ◆ JESD8-B (2.7 V to 3.6 V)
- ESD protection:
 - ◆ HBM JESD22-A114-C Class 3A. Exceeds 5000 V
 - ◆ MM JESD22-A115-A exceeds 200 V
 - ◆ CDM JESD22-C101-C exceeds 1000 V
- Low static power consumption; $I_{CC} = 0.9 \mu\text{A}$ (maximum)
- Latch-up performance exceeds 100 mA per JESD 78 Class II
- Inputs accept voltages up to 3.6 V
- Low noise overshoot and undershoot $< 10\%$ of V_{CC}
- I_{OFF} circuitry provides partial Power-down mode operation
- Multiple package options
- Specified from $-40\text{ }^{\circ}\text{C}$ to $+85\text{ }^{\circ}\text{C}$ and $-40\text{ }^{\circ}\text{C}$ to $+125\text{ }^{\circ}\text{C}$

3. Quick reference data

Table 1: Quick reference data
 $GND = 0\text{ V}; T_{amb} = 25\text{ }^{\circ}\text{C}; t_r = t_f \leq 3\text{ ns.}$

| Symbol | Parameter | Conditions | Min | Typ | Max | Unit | |
|--------------------|--------------------------------------------------------|-------------------------------------------------------------------------------------------|--------|------|------|------|----|
| t_{PHL}, t_{PLH} | HIGH-to-LOW and LOW-to-HIGH propagation delay nA to nY | $C_L = 5\text{ pF}; R_L = 1\text{ M}\Omega;$ $V_{CC} = 0.8\text{ V}$ | - | 16.0 | - | ns | |
| | | $C_L = 5\text{ pF}; R_L = 1\text{ M}\Omega;$ $V_{CC} = 1.1\text{ V to }1.3\text{ V}$ | 2.4 | 5.0 | 10.3 | ns | |
| | | $C_L = 5\text{ pF}; R_L = 1\text{ M}\Omega;$ $V_{CC} = 1.4\text{ V to }1.6\text{ V}$ | 1.8 | 3.6 | 6.4 | ns | |
| | | $C_L = 5\text{ pF}; R_L = 1\text{ M}\Omega;$ $V_{CC} = 1.65\text{ V to }1.95\text{ V}$ | 1.5 | 2.9 | 5.0 | ns | |
| | | $C_L = 5\text{ pF}; R_L = 1\text{ M}\Omega;$ $V_{CC} = 2.3\text{ V to }2.7\text{ V}$ | 1.2 | 2.4 | 3.9 | ns | |
| | | $C_L = 5\text{ pF}; R_L = 1\text{ M}\Omega;$ $V_{CC} = 3.0\text{ V to }3.6\text{ V}$ | 1.1 | 2.1 | 3.2 | ns | |
| C_I | input capacitance | | - | 1.0 | - | pF | |
| C_{PD} | power dissipation capacitance | $V_{CC} = 1.8\text{ V}; f_i = 1\text{ MHz}$ | [1][2] | - | 3.2 | - | pF |
| | | $V_{CC} = 3.3\text{ V}; f_i = 1\text{ MHz}$ | [1][2] | - | 4.3 | - | pF |

[1] C_{PD} is used to determine the dynamic power dissipation (P_D in μW).

$$P_D = C_{PD} \times V_{CC}^2 \times f_i \times N + \Sigma(C_L \times V_{CC}^2 \times f_o)$$
 where:

 f_i = input frequency in MHz;

 f_o = output frequency in MHz;

 C_L = load capacitance in pF;

 V_{CC} = supply voltage in V;

 N = number of inputs switching;

 $\Sigma(C_L \times V_{CC}^2 \times f_o)$ = sum of the outputs.

[2] The condition is $V_i = GND$ to V_{CC} .

4. Ordering information

Table 2: Ordering information

| Type number | Package | | | Version |
|-------------|-------------------|-------|----------------------------------------------------------------------------------------------------------------|---------|
| | Temperature range | Name | Description | |
| 74AUP2G04GW | -40 °C to +125 °C | SC-88 | plastic surface mounted package; 6 leads | SOT363 |
| 74AUP2G04GM | -40 °C to +125 °C | XSON6 | plastic extremely thin small outline package; no leads; 6 terminals; body $1 \times 1.45 \times 0.5\text{ mm}$ | SOT886 |
| 74AUP2G04GF | -40 °C to +125 °C | XSON6 | plastic extremely thin small outline package; no leads; 6 terminals; body $1 \times 1 \times 0.5\text{ mm}$ | SOT891 |

5. Marking

Table 3: Marking

| Type number | Marking code |
|-------------|--------------|
| 74AUP2G04GW | p4 |
| 74AUP2G04GM | p4 |
| 74AUP2G04GF | p4 |

6. Functional diagram

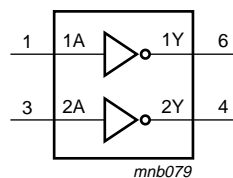

Fig 1. Logic symbol

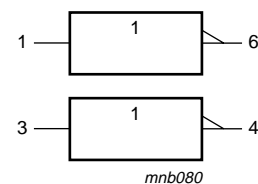

Fig 2. IEC logic symbol

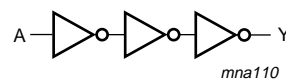

Fig 3. Logic diagram (one gate)

7. Pinning information

7.1 Pinning

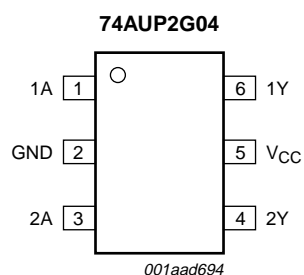

Fig 4. Pin configuration SOT363 (SC-88)

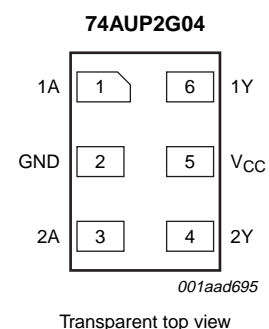
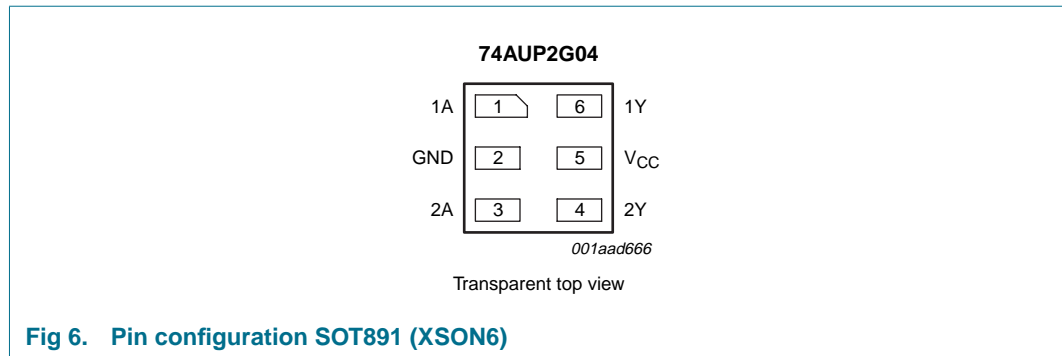

Fig 5. Pin configuration SOT886 (XSON6)



7.2 Pin description

Table 4: Pin description

| Symbol | Pin | Description |
|-----------------|-----|----------------|
| 1A | 1 | data input 1A |
| GND | 2 | ground (0 V) |
| 2A | 3 | data input 2A |
| 2Y | 4 | data output 2Y |
| V _{CC} | 5 | supply voltage |
| 1Y | 6 | data output 1Y |

8. Functional description

8.1 Function table

Table 5: Function table [\[1\]](#)

| Input | Output |
|-------|--------|
| nA | nY |
| L | H |
| H | L |

[1] H = HIGH voltage level;
L = LOW voltage level.

9. Limiting values

Table 6: Limiting values

In accordance with the Absolute Maximum Rating System (IEC 60134). Voltages are referenced to GND (ground = 0 V).

| Symbol | Parameter | Conditions | Min | Max | Unit |
|-----------|--------------------------|---------------------------------|----------|------|------|
| V_{CC} | supply voltage | | -0.5 | +4.6 | V |
| I_{IK} | input clamping current | $V_I < 0$ V | - | -50 | mA |
| V_I | input voltage | | [1] -0.5 | +4.6 | V |
| I_{OK} | output clamping current | $V_O < 0$ V | - | -50 | mA |
| V_O | output voltage | active mode and Power-down mode | [1] -0.5 | +4.6 | V |
| I_O | output current | $V_O = 0$ V to V_{CC} | - | ±20 | mA |
| I_{CC} | quiescent supply current | | - | +50 | mA |
| I_{GND} | ground current | | - | -50 | mA |
| T_{stg} | storage temperature | | -65 | +150 | °C |
| P_{tot} | total power dissipation | $T_{amb} = -40$ °C to +125 °C | [2] - | 250 | mW |

[1] The minimum input and output voltage ratings may be exceeded if the input and output current ratings are observed.

[2] For SC-88 packages: above 87.5 °C the value of P_{tot} derates linearly with 4.0 mW/K.
For XSON6 packages: above 45 °C the value of P_{tot} derates linearly with 2.4 mW/K.

10. Recommended operating conditions

Table 7: Recommended operating conditions

| Symbol | Parameter | Conditions | Min | Max | Unit |
|---------------------|-------------------------------------|---------------------------------|-----|----------|------|
| V_{CC} | supply voltage | | 0.8 | 3.6 | V |
| V_I | input voltage | | 0 | 3.6 | V |
| V_O | output voltage | active mode | 0 | V_{CC} | V |
| | | Power-down mode; $V_{CC} = 0$ V | 0 | 3.6 | V |
| T_{amb} | ambient temperature | | -40 | +125 | °C |
| $\Delta t/\Delta V$ | input transition rise and fall rate | $V_{CC} = 0.8$ V to 3.6 V | 0 | 200 | ns/V |

11. Static characteristics

Table 8: Static characteristics

At recommended operating conditions; voltages are referenced to GND (ground = 0 V).

| Symbol | Parameter | Conditions | Min | Typ | Max | Unit |
|--------------------------------|--------------------------------------|--------------------------------------------------------------------------------------------------|------------------------|-----|------------------------|------|
| T_{amb} = 25 °C | | | | | | |
| V _{IH} | HIGH-state input voltage | V _{CC} = 0.8 V | 0.70 × V _{CC} | - | - | V |
| | | V _{CC} = 0.9 V to 1.95 V | 0.65 × V _{CC} | - | - | V |
| | | V _{CC} = 2.3 V to 2.7 V | 1.6 | - | - | V |
| | | V _{CC} = 3.0 V to 3.6 V | 2.0 | - | - | V |
| V _{IL} | LOW-state input voltage | V _{CC} = 0.8 V | - | - | 0.30 × V _{CC} | V |
| | | V _{CC} = 0.9 V to 1.95 V | - | - | 0.35 × V _{CC} | V |
| | | V _{CC} = 2.3 V to 2.7 V | - | - | 0.7 | V |
| | | V _{CC} = 3.0 V to 3.6 V | - | - | 0.9 | V |
| V _{OH} | HIGH-state output voltage | V _I = V _{IH} or V _{IL} | | | | |
| | | I _O = -20 μA; V _{CC} = 0.8 V to 3.6 V | V _{CC} - 0.1 | - | - | V |
| | | I _O = -1.1 mA; V _{CC} = 1.1 V | 0.75 × V _{CC} | - | - | V |
| | | I _O = -1.7 mA; V _{CC} = 1.4 V | 1.11 | - | - | V |
| | | I _O = -1.9 mA; V _{CC} = 1.65 V | 1.32 | - | - | V |
| | | I _O = -2.3 mA; V _{CC} = 2.3 V | 2.05 | - | - | V |
| | | I _O = -3.1 mA; V _{CC} = 2.3 V | 1.9 | - | - | V |
| | | I _O = -2.7 mA; V _{CC} = 3.0 V | 2.72 | - | - | V |
| V _{OL} | LOW-state output voltage | V _I = V _{IH} or V _{IL} | | | | |
| | | I _O = 20 μA; V _{CC} = 0.8 V to 3.6 V | - | - | 0.1 | V |
| | | I _O = 1.1 mA; V _{CC} = 1.1 V | - | - | 0.3 × V _{CC} | V |
| | | I _O = 1.7 mA; V _{CC} = 1.4 V | - | - | 0.31 | V |
| | | I _O = 1.9 mA; V _{CC} = 1.65 V | - | - | 0.31 | V |
| | | I _O = 2.3 mA; V _{CC} = 2.3 V | - | - | 0.31 | V |
| | | I _O = 3.1 mA; V _{CC} = 2.3 V | - | - | 0.44 | V |
| | | I _O = 2.7 mA; V _{CC} = 3.0 V | - | - | 0.31 | V |
| | | I _O = 4.0 mA; V _{CC} = 3.0 V | - | - | 0.44 | V |
| I _I | input leakage current | V _I = GND to 3.6 V; V _{CC} = 0 V to 3.6 V | - | - | ±0.1 | μA |
| I _{OFF} | power-off leakage current | V _I or V _O = 0 V to 3.6 V; V _{CC} = 0 V | - | - | ±0.2 | μA |
| ΔI _{OFF} | additional power-off leakage current | V _I or V _O = 0 V to 3.6 V; V _{CC} = 0 V to 0.2 V | - | - | ±0.2 | μA |
| I _{CC} | quiescent supply current | V _I = GND or V _{CC} ; I _O = 0 A; V _{CC} = 0.8 V to 3.6 V | - | - | 0.5 | μA |
| ΔI _{CC} | additional quiescent supply current | V _I = V _{CC} - 0.6 V; I _O = 0 A; V _{CC} = 3.3 V | - | - | 40 | μA |
| C _I | input capacitance | V _{CC} = 0 V to 3.6 V; V _I = GND or V _{CC} | - | 1.0 | - | pF |
| C _O | output capacitance | V _O = GND; V _{CC} = 0 V | - | 1.8 | - | pF |

Table 8: Static characteristics ...continued

At recommended operating conditions; voltages are referenced to GND (ground = 0 V).

| Symbol | Parameter | Conditions | Min | Typ | Max | Unit |
|-------------------------------------------|--------------------------------------|--------------------------------------------------------------------------------------------------|------------------------|-----|------------------------|------|
| T_{amb} = -40 °C to +85 °C | | | | | | |
| V _{IH} | HIGH-state input voltage | V _{CC} = 0.8 V | 0.70 × V _{CC} | - | - | V |
| | | V _{CC} = 0.9 V to 1.95 V | 0.65 × V _{CC} | - | - | V |
| | | V _{CC} = 2.3 V to 2.7 V | 1.6 | - | - | V |
| | | V _{CC} = 3.0 V to 3.6 V | 2.0 | - | - | V |
| V _{IL} | LOW-state input voltage | V _{CC} = 0.8 V | - | - | 0.30 × V _{CC} | V |
| | | V _{CC} = 0.9 V to 1.95 V | - | - | 0.35 × V _{CC} | V |
| | | V _{CC} = 2.3 V to 2.7 V | - | - | 0.7 | V |
| | | V _{CC} = 3.0 V to 3.6 V | - | - | 0.9 | V |
| V _{OH} | HIGH-state output voltage | V _I = V _{IH} or V _{IL} | | | | |
| | | I _O = -20 μA; V _{CC} = 0.8 V to 3.6 V | V _{CC} - 0.1 | - | - | V |
| | | I _O = -1.1 mA; V _{CC} = 1.1 V | 0.7 × V _{CC} | - | - | V |
| | | I _O = -1.7 mA; V _{CC} = 1.4 V | 1.03 | - | - | V |
| | | I _O = -1.9 mA; V _{CC} = 1.65 V | 1.30 | - | - | V |
| | | I _O = -2.3 mA; V _{CC} = 2.3 V | 1.97 | - | - | V |
| | | I _O = -3.1 mA; V _{CC} = 2.3 V | 1.85 | - | - | V |
| | | I _O = -2.7 mA; V _{CC} = 3.0 V | 2.67 | - | - | V |
| V _{OL} | LOW-state output voltage | V _I = V _{IH} or V _{IL} | | | | |
| | | I _O = 20 μA; V _{CC} = 0.8 V to 3.6 V | - | - | 0.1 | V |
| | | I _O = 1.1 mA; V _{CC} = 1.1 V | - | - | 0.3 × V _{CC} | V |
| | | I _O = 1.7 mA; V _{CC} = 1.4 V | - | - | 0.37 | V |
| | | I _O = 1.9 mA; V _{CC} = 1.65 V | - | - | 0.35 | V |
| | | I _O = 2.3 mA; V _{CC} = 2.3 V | - | - | 0.33 | V |
| | | I _O = 3.1 mA; V _{CC} = 2.3 V | - | - | 0.45 | V |
| | | I _O = 2.7 mA; V _{CC} = 3.0 V | - | - | 0.33 | V |
| I _I | input leakage current | V _I = GND to 3.6 V; V _{CC} = 0 V to 3.6 V | - | - | ±0.5 | μA |
| | | V _I or V _O = 0 V to 3.6 V; V _{CC} = 0 V | - | - | ±0.5 | μA |
| ΔI _{OFF} | additional power-off leakage current | V _I or V _O = 0 V to 3.6 V; V _{CC} = 0 V to 0.2 V | - | - | ±0.6 | μA |
| I _{CC} | quiescent supply current | V _I = GND or V _{CC} ; I _O = 0 A; V _{CC} = 0.8 V to 3.6 V | - | - | 0.9 | μA |
| ΔI _{CC} | additional quiescent supply current | V _I = V _{CC} - 0.6 V; I _O = 0 A; V _{CC} = 3.3 V | - | - | 50 | μA |

Table 8: Static characteristics ...continued

At recommended operating conditions; voltages are referenced to GND (ground = 0 V).

| Symbol | Parameter | Conditions | Min | Typ | Max | Unit |
|--------------------------------------------|--------------------------------------|--------------------------------------------------------------------------------------------------|------------------------|-----|------------------------|------|
| T_{amb} = -40 °C to +125 °C | | | | | | |
| V _{IH} | HIGH-state input voltage | V _{CC} = 0.8 V | 0.75 × V _{CC} | - | - | V |
| | | V _{CC} = 0.9 V to 1.95 V | 0.70 × V _{CC} | - | - | V |
| | | V _{CC} = 2.3 V to 2.7 V | 1.6 | - | - | V |
| | | V _{CC} = 3.0 V to 3.6 V | 2.0 | - | - | V |
| V _{IL} | LOW-state input voltage | V _{CC} = 0.8 V | - | - | 0.25 × V _{CC} | V |
| | | V _{CC} = 0.9 V to 1.95 V | - | - | 0.30 × V _{CC} | V |
| | | V _{CC} = 2.3 V to 2.7 V | - | - | 0.7 | V |
| | | V _{CC} = 3.0 V to 3.6 V | - | - | 0.9 | V |
| V _{OH} | HIGH-state output voltage | V _I = V _{IH} or V _{IL} | | | | |
| | | I _O = -20 μA; V _{CC} = 0.8 V to 3.6 V | V _{CC} - 0.11 | - | - | V |
| | | I _O = -1.1 mA; V _{CC} = 1.1 V | 0.6 × V _{CC} | - | - | V |
| | | I _O = -1.7 mA; V _{CC} = 1.4 V | 0.93 | - | - | V |
| | | I _O = -1.9 mA; V _{CC} = 1.65 V | 1.17 | - | - | V |
| | | I _O = -2.3 mA; V _{CC} = 2.3 V | 1.77 | - | - | V |
| | | I _O = -3.1 mA; V _{CC} = 2.3 V | 1.67 | - | - | V |
| | | I _O = -2.7 mA; V _{CC} = 3.0 V | 2.40 | - | - | V |
| V _{OL} | LOW-state output voltage | V _I = V _{IH} or V _{IL} | | | | |
| | | I _O = 20 μA; V _{CC} = 0.8 V to 3.6 V | - | - | 0.11 | V |
| | | I _O = 1.1 mA; V _{CC} = 1.1 V | - | - | 0.33 × V _{CC} | V |
| | | I _O = 1.7 mA; V _{CC} = 1.4 V | - | - | 0.41 | V |
| | | I _O = 1.9 mA; V _{CC} = 1.65 V | - | - | 0.39 | V |
| | | I _O = 2.3 mA; V _{CC} = 2.3 V | - | - | 0.36 | V |
| | | I _O = 3.1 mA; V _{CC} = 2.3 V | - | - | 0.50 | V |
| | | I _O = 2.7 mA; V _{CC} = 3.0 V | - | - | 0.36 | V |
| I _I | input leakage current | V _I = GND to 3.6 V; V _{CC} = 0 V to 3.6 V | - | - | ±0.75 | μA |
| | | V _I or V _O = 0 V to 3.6 V; V _{CC} = 0 V | - | - | ±0.75 | μA |
| ΔI _{OFF} | additional power-off leakage current | V _I or V _O = 0 V to 3.6 V; V _{CC} = 0 V to 0.2 V | - | - | ±0.75 | μA |
| I _{CC} | quiescent supply current | V _I = GND or V _{CC} ; I _O = 0 A; V _{CC} = 0.8 V to 3.6 V | - | - | 1.4 | μA |
| ΔI _{CC} | additional quiescent supply current | V _I = V _{CC} - 0.6 V; I _O = 0 A; V _{CC} = 3.3 V | - | - | 75 | μA |

12. Dynamic characteristics

Table 9: Dynamic characteristics

Voltages are referenced to GND (ground = 0 V); for test circuit see [Figure 8](#)

| Symbol | Parameter | Conditions | Min | Typ [1] | Max | Unit |
|-------------------------------------------------------------------------------------------|--------------------------------------------------------|-------------------------------------------|-----|---------|------|------|
| $T_{amb} = 25\text{ }^{\circ}\text{C}$; $C_L = 5\text{ pF}$ | | | | | | |
| t_{PHL} , t_{PLH} | HIGH-to-LOW and LOW-to-HIGH propagation delay nA to nY | see Figure 7 | | | | |
| | | $V_{CC} = 0.8\text{ V}$ | - | 16.0 | - | ns |
| | | $V_{CC} = 1.1\text{ V to }1.3\text{ V}$ | 2.4 | 5.0 | 10.3 | ns |
| | | $V_{CC} = 1.4\text{ V to }1.6\text{ V}$ | 1.8 | 3.6 | 6.4 | ns |
| | | $V_{CC} = 1.65\text{ V to }1.95\text{ V}$ | 1.5 | 2.9 | 5.0 | ns |
| | | $V_{CC} = 2.3\text{ V to }2.7\text{ V}$ | 1.2 | 2.4 | 3.9 | ns |
| | | $V_{CC} = 3.0\text{ V to }3.6\text{ V}$ | 1.1 | 2.1 | 3.2 | ns |
| $T_{amb} = 25\text{ }^{\circ}\text{C}$; $C_L = 10\text{ pF}$ | | | | | | |
| t_{PHL} , t_{PLH} | HIGH-to-LOW and LOW-to-HIGH propagation delay nA to nY | see Figure 7 | | | | |
| | | $V_{CC} = 0.8\text{ V}$ | - | 19.8 | - | ns |
| | | $V_{CC} = 1.1\text{ V to }1.3\text{ V}$ | 2.8 | 5.9 | 12.2 | ns |
| | | $V_{CC} = 1.4\text{ V to }1.6\text{ V}$ | 2.3 | 4.2 | 7.5 | ns |
| | | $V_{CC} = 1.65\text{ V to }1.95\text{ V}$ | 2.0 | 3.5 | 5.9 | ns |
| | | $V_{CC} = 2.3\text{ V to }2.7\text{ V}$ | 1.7 | 2.9 | 4.6 | ns |
| | | $V_{CC} = 3.0\text{ V to }3.6\text{ V}$ | 1.6 | 2.7 | 3.8 | ns |
| $T_{amb} = 25\text{ }^{\circ}\text{C}$; $C_L = 15\text{ pF}$ | | | | | | |
| t_{PHL} , t_{PLH} | HIGH-to-LOW and LOW-to-HIGH propagation delay nA to nY | see Figure 7 | | | | |
| | | $V_{CC} = 0.8\text{ V}$ | - | 23.3 | - | ns |
| | | $V_{CC} = 1.1\text{ V to }1.3\text{ V}$ | 3.2 | 6.7 | 13.0 | ns |
| | | $V_{CC} = 1.4\text{ V to }1.6\text{ V}$ | 2.6 | 4.7 | 8.6 | ns |
| | | $V_{CC} = 1.65\text{ V to }1.95\text{ V}$ | 2.3 | 4.0 | 6.7 | ns |
| | | $V_{CC} = 2.3\text{ V to }2.7\text{ V}$ | 2.1 | 3.3 | 5.1 | ns |
| | | $V_{CC} = 3.0\text{ V to }3.6\text{ V}$ | 2.0 | 3.1 | 4.2 | ns |
| $T_{amb} = 25\text{ }^{\circ}\text{C}$; $C_L = 30\text{ pF}$ | | | | | | |
| t_{PHL} , t_{PLH} | HIGH-to-LOW and LOW-to-HIGH propagation delay nA to nY | see Figure 7 | | | | |
| | | $V_{CC} = 0.8\text{ V}$ | - | 33.6 | - | ns |
| | | $V_{CC} = 1.1\text{ V to }1.3\text{ V}$ | 4.4 | 8.9 | 16.0 | ns |
| | | $V_{CC} = 1.4\text{ V to }1.6\text{ V}$ | 3.6 | 6.3 | 10.8 | ns |
| | | $V_{CC} = 1.65\text{ V to }1.95\text{ V}$ | 3.2 | 5.3 | 9.0 | ns |
| | | $V_{CC} = 2.3\text{ V to }2.7\text{ V}$ | 2.9 | 4.5 | 6.5 | ns |
| | | $V_{CC} = 3.0\text{ V to }3.6\text{ V}$ | 2.9 | 4.2 | 5.4 | ns |

Table 9: Dynamic characteristics ...continuedVoltages are referenced to GND (ground = 0 V); for test circuit see [Figure 8](#)

| Symbol | Parameter | Conditions | Min | Typ [1] | Max | Unit |
|--------------------------------|-------------------------------|------------------------------------|---------|---------|-----|------|
| T_{amb} = 25 °C | | | | | | |
| C _{PD} | power dissipation capacitance | f _i = 1 MHz | [2] [3] | | | |
| | | V _{CC} = 0.8 V | - | 2.8 | - | pF |
| | | V _{CC} = 1.1 V to 1.3 V | - | 3.0 | - | pF |
| | | V _{CC} = 1.4 V to 1.6 V | - | 3.1 | - | pF |
| | | V _{CC} = 1.65 V to 1.95 V | - | 3.2 | - | pF |
| | | V _{CC} = 2.3 V to 2.7 V | - | 3.7 | - | pF |
| | | V _{CC} = 3.0 V to 3.6 V | - | 4.3 | - | pF |

[1] All typical values are measured at nominal V_{CC}.[2] C_{PD} is used to determine the dynamic power dissipation (P_D in μW).P_D = C_{PD} × V_{CC}² × f_i × N + Σ(C_L × V_{CC}² × f_o) where:f_i = input frequency in MHz;f_o = output frequency in MHz;C_L = load capacitance in pF;V_{CC} = supply voltage in V;

N = number of inputs switching;

Σ(C_L × V_{CC}² × f_o) = sum of the outputs.[3] The condition is V_I = GND to V_{CC}.**Table 10: Dynamic characteristics**Voltages are referenced to GND (ground = 0 V); for test circuit see [Figure 8](#)

| Symbol | Parameter | Conditions | -40 °C to +85 °C | | -40 °C to +125 °C | | Unit |
|-------------------------------------|-----------------------------------------------------------|------------------------------------|------------------|------|-------------------|------|------|
| | | | Min | Max | Min | Max | |
| C_L = 5 pF | | | | | | | |
| t _{PHL} , t _{PLH} | HIGH-to-LOW and LOW-to-HIGH propagation delay nA to nY | see Figure 7 | | | | | |
| | | V _{CC} = 1.1 V to 1.3 V | 2.1 | 11.4 | 2.1 | 12.6 | ns |
| | | V _{CC} = 1.4 V to 1.6 V | 1.6 | 7.4 | 1.6 | 8.2 | ns |
| | | V _{CC} = 1.65 V to 1.95 V | 1.4 | 5.9 | 1.4 | 6.5 | ns |
| | | V _{CC} = 2.3 V to 2.7 V | 1.1 | 4.5 | 1.1 | 5.0 | ns |
| | | V _{CC} = 3.0 V to 3.6 V | 1.0 | 3.9 | 1.0 | 4.3 | ns |
| C_L = 10 pF | | | | | | | |
| t _{PHL} , t _{PLH} | HIGH-to-LOW and LOW-to-HIGH propagation delay nA to nY | see Figure 7 | | | | | |
| | | V _{CC} = 1.1 V to 1.3 V | 2.6 | 13.7 | 2.6 | 15.1 | ns |
| | | V _{CC} = 1.4 V to 1.6 V | 2.1 | 8.7 | 2.1 | 9.6 | ns |
| | | V _{CC} = 1.65 V to 1.95 V | 1.8 | 7.0 | 1.8 | 7.7 | ns |
| | | V _{CC} = 2.3 V to 2.7 V | 1.5 | 5.4 | 1.5 | 6.0 | ns |
| | | V _{CC} = 3.0 V to 3.6 V | 1.4 | 4.5 | 1.4 | 5.0 | ns |

Table 10: Dynamic characteristics ...continuedVoltages are referenced to GND (ground = 0 V); for test circuit see [Figure 8](#)

| Symbol | Parameter | Conditions | -40 °C to +85 °C | | -40 °C to +125 °C | | Unit |
|-----------------------------------------|-----------------------------------------------------------|-----------------------------------------------------|------------------|------|-------------------|------|------|
| | | | Min | Max | Min | Max | |
| $C_L = 15 \text{ pF}$ | | | | | | | |
| $t_{\text{PHL}}, t_{\text{PLH}}$ | HIGH-to-LOW and LOW-to-HIGH propagation delay nA to nY | see Figure 7 | | | | | |
| | | $V_{\text{CC}} = 1.1 \text{ V to } 1.3 \text{ V}$ | 3.0 | 15.8 | 3.0 | 17.4 | ns |
| | | $V_{\text{CC}} = 1.4 \text{ V to } 1.6 \text{ V}$ | 2.4 | 10.0 | 2.4 | 11.0 | ns |
| | | $V_{\text{CC}} = 1.65 \text{ V to } 1.95 \text{ V}$ | 2.1 | 8.0 | 2.1 | 8.8 | ns |
| | | $V_{\text{CC}} = 2.3 \text{ V to } 2.7 \text{ V}$ | 1.8 | 6.1 | 1.8 | 6.8 | ns |
| | | $V_{\text{CC}} = 3.0 \text{ V to } 3.6 \text{ V}$ | 1.8 | 5.0 | 1.8 | 5.5 | ns |
| $C_L = 30 \text{ pF}$ | | | | | | | |
| $t_{\text{PHL}}, t_{\text{PLH}}$ | HIGH-to-LOW and LOW-to-HIGH propagation delay nA to nY | see Figure 7 | | | | | |
| | | $V_{\text{CC}} = 1.1 \text{ V to } 1.3 \text{ V}$ | 4.0 | 19.0 | 4.0 | 20.9 | ns |
| | | $V_{\text{CC}} = 1.4 \text{ V to } 1.6 \text{ V}$ | 3.2 | 12.9 | 3.2 | 14.2 | ns |
| | | $V_{\text{CC}} = 1.65 \text{ V to } 1.95 \text{ V}$ | 2.9 | 10.5 | 2.9 | 11.6 | ns |
| | | $V_{\text{CC}} = 2.3 \text{ V to } 2.7 \text{ V}$ | 2.6 | 7.6 | 2.6 | 8.4 | ns |
| | | $V_{\text{CC}} = 3.0 \text{ V to } 3.6 \text{ V}$ | 2.6 | 6.2 | 2.6 | 6.9 | ns |

13. Waveforms

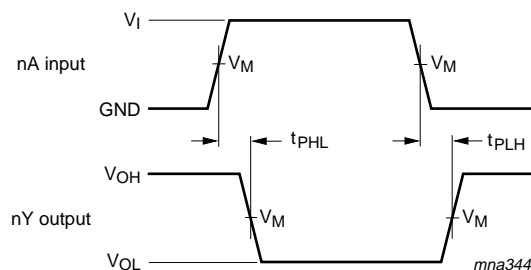
Measurement points are given in [Table 11](#).Logic levels: V_{OL} and V_{OH} are typical output voltage drop that occur with the output load.**Fig 7. The data input (nA) to output (nY) propagation delays****Table 11: Measurement points**

| Supply voltage | Output | Input | | |
|-----------------|----------------------------|----------------------------|-----------------|-----------------------|
| V_{CC} | V_{M} | V_{M} | V_{I} | $t_r = t_f$ |
| 0.8 V to 3.6 V | $0.5 \times V_{\text{CC}}$ | $0.5 \times V_{\text{CC}}$ | V_{CC} | $\leq 3.0 \text{ ns}$ |

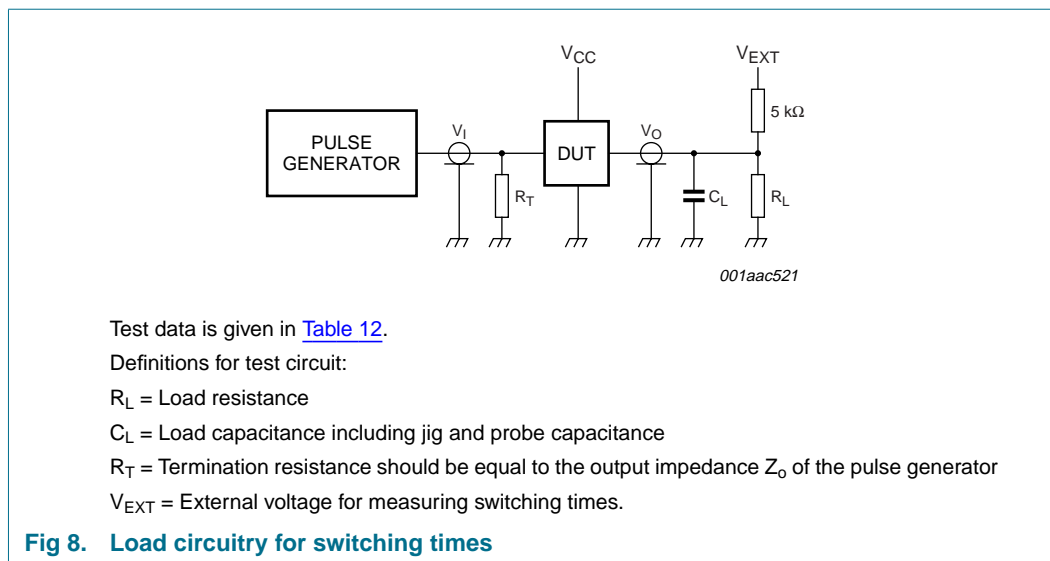

Fig 8. Load circuitry for switching times

Table 12: Test data

| Supply voltage | Load | | V_{EXT} | | |
|----------------|---------------------------------|--------------|-----------------------|-----------------------|-----------------------|
| V_{CC} | C_L | R_L [1] | t_{PLH} , t_{PHL} | t_{PZH} , t_{PHZ} | t_{PZL} , t_{PLZ} |
| 0.8 V to 3.6 V | 5 pF, 10 pF, 15 pF and 30 pF | 5 kΩ or 1 MΩ | open | GND | $2 \times V_{CC}$ |

[1] For measuring enable and disable times $R_L = 5 \text{ k}\Omega$, for measuring propagation delays, setup and hold times and pulse width $R_L = 1 \text{ M}\Omega$

14. Package outline

Plastic surface mounted package; 6 leads

SOT363

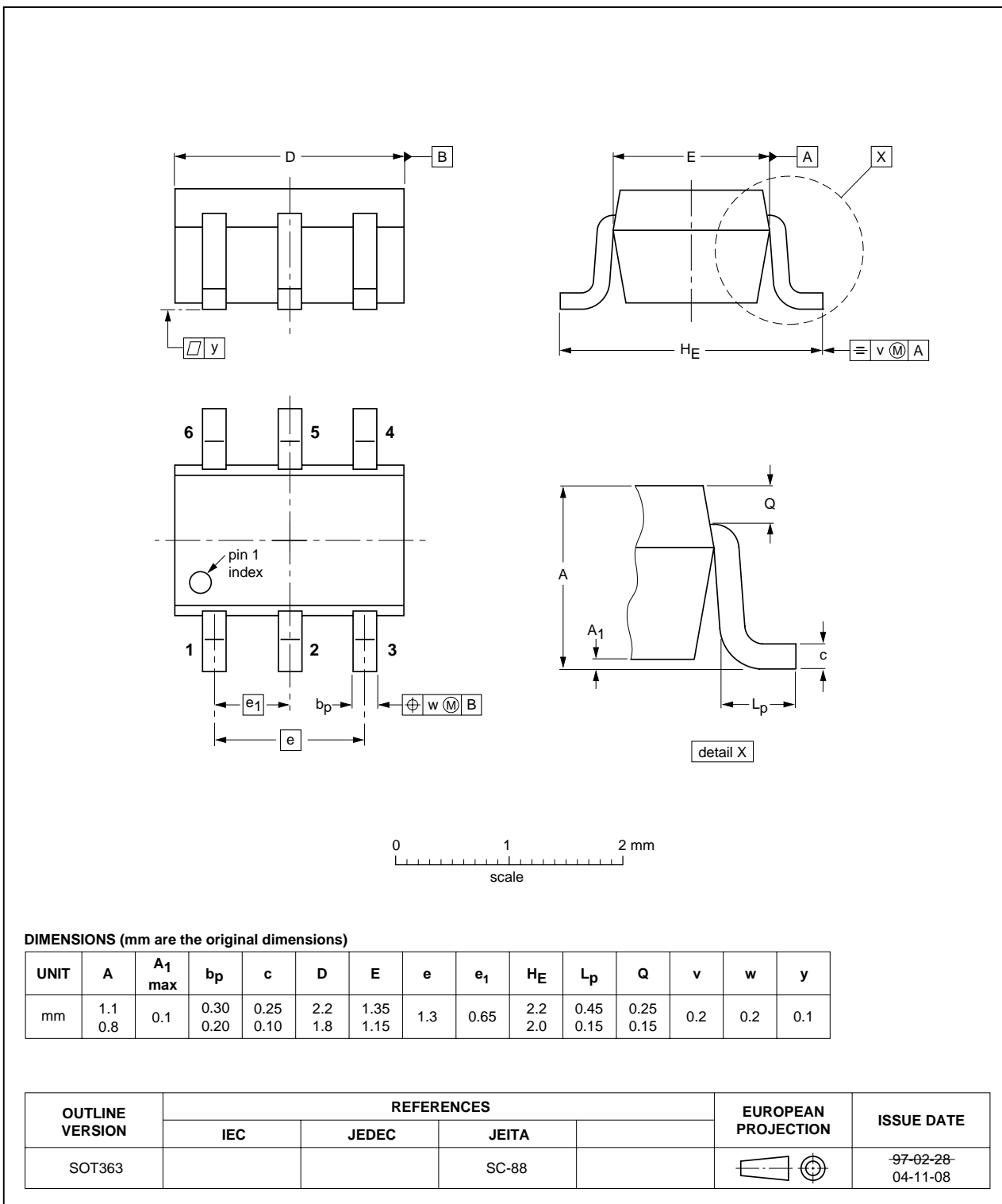

Fig 9. Package outline SOT363 (SC-88)

XSON6: plastic extremely thin small outline package; no leads; 6 terminals; body 1 x 1.45 x 0.5 mm

SOT886

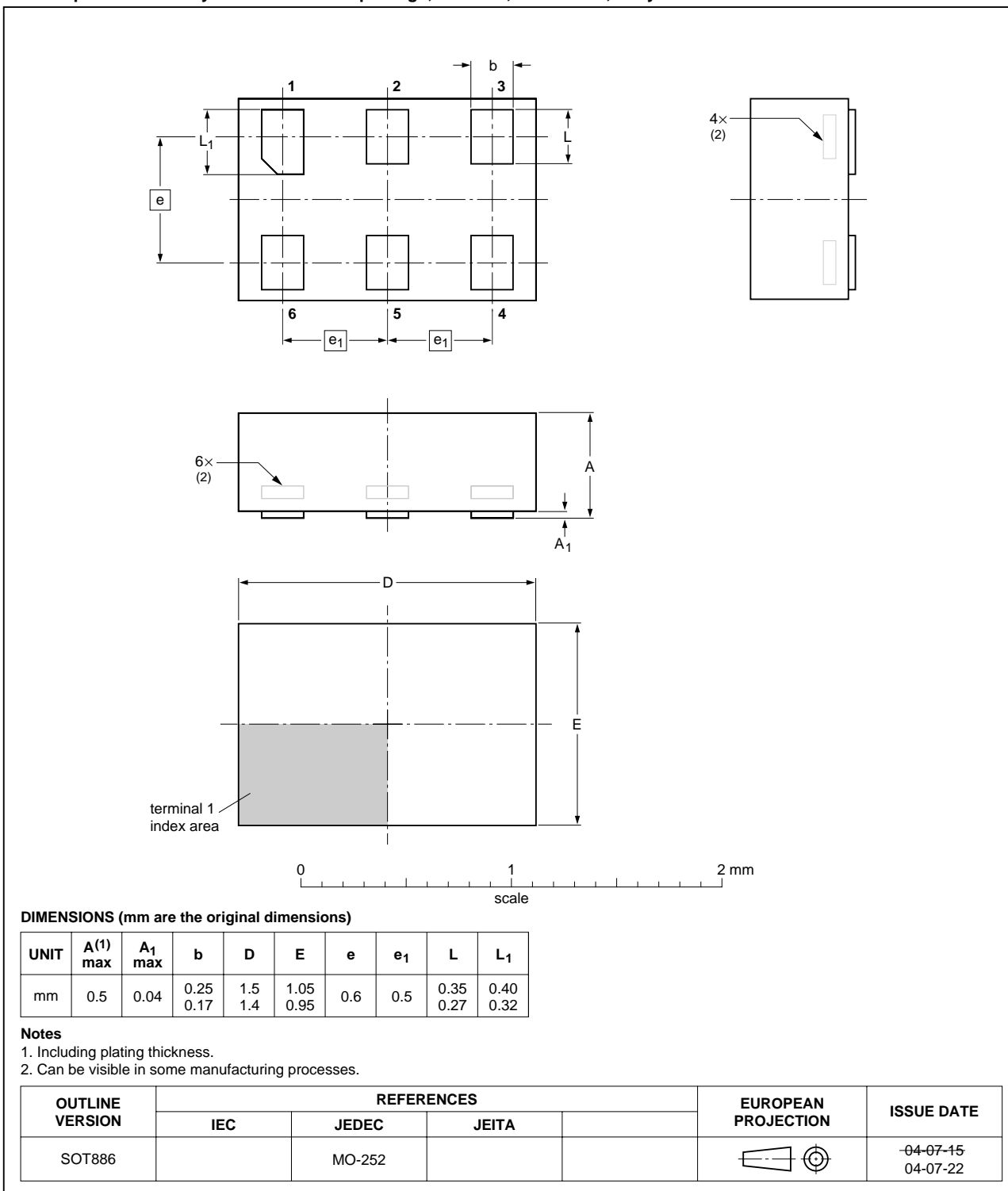

Fig 10. Package outline SOT886 (XSON6)

XSON6: plastic extremely thin small outline package; no leads; 6 terminals; body 1 x 1 x 0.5 mm

SOT891

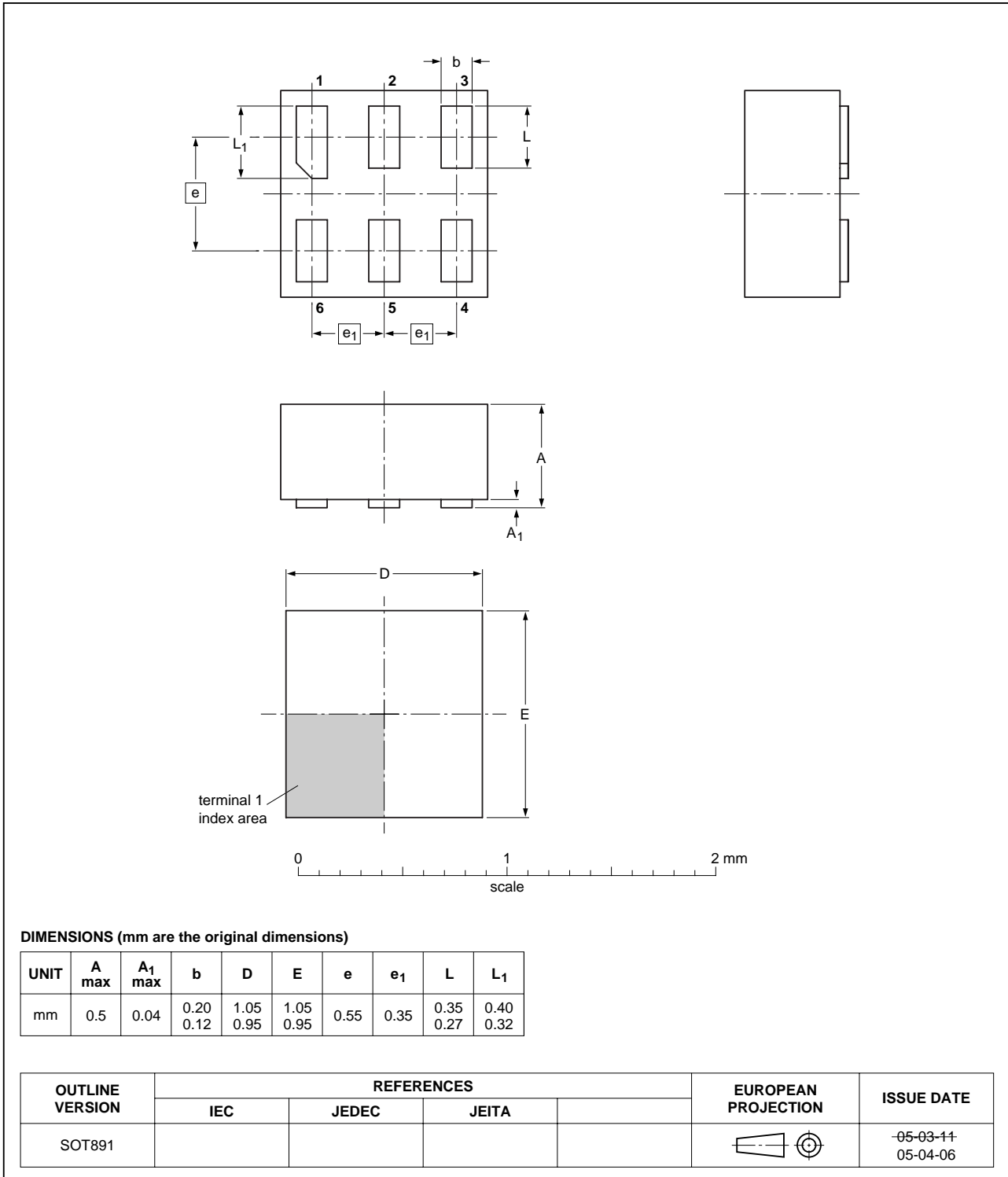

Fig 11. Package outline SOT891 (XSON6)

15. Abbreviations

Table 13: Abbreviations

| Acronym | Description |
|---------|-----------------------------------------|
| CDM | Charged Device Model |
| CMOS | Complementary Metal Oxide Semiconductor |
| DUT | Device Under Test |
| ESD | ElectroStatic Discharge |
| HBM | Human Body Model |
| MM | Machine Model |
| TTL | Transistor Transistor Logic |

16. Revision history

Table 14: Revision history

| Document ID | Release date | Data sheet status | Change notice | Doc. number | Supersedes |
|-------------|--------------|--------------------|---------------|-------------|------------|
| 74AUP2G04_1 | <td> | Product data sheet | - | - | - |

17. Data sheet status

| Level | Data sheet status ^[1] | Product status ^{[2] [3]} | Definition |
|-------|----------------------------------|-----------------------------------|------------------------------------------------------------------------------------------------------------------------------------------------------------------------------------------------------------------------------------------------------------------------------------------------|
| I | Objective data | Development | This data sheet contains data from the objective specification for product development. Philips Semiconductors reserves the right to change the specification in any manner without notice. |
| II | Preliminary data | Qualification | This data sheet contains data from the preliminary specification. Supplementary data will be published at a later date. Philips Semiconductors reserves the right to change the specification without notice, in order to improve the design and supply the best possible product. |
| III | Product data | Production | This data sheet contains data from the product specification. Philips Semiconductors reserves the right to make changes at any time in order to improve the design, manufacturing and supply. Relevant changes will be communicated via a Customer Product/Process Change Notification (CPCN). |

[1] Please consult the most recently issued data sheet before initiating or completing a design.

[2] The product status of the device(s) described in this data sheet may have changed since this data sheet was published. The latest information is available on the Internet at URL <http://www.semiconductors.philips.com>.

[3] For data sheets describing multiple type numbers, the highest-level product status determines the data sheet status.

18. Definitions

Short-form specification — The data in a short-form specification is extracted from a full data sheet with the same type number and title. For detailed information see the relevant data sheet or data handbook.

Limiting values definition — Limiting values given are in accordance with the Absolute Maximum Rating System (IEC 60134). Stress above one or more of the limiting values may cause permanent damage to the device. These are stress ratings only and operation of the device at these or at any other conditions above those given in the Characteristics sections of the specification is not implied. Exposure to limiting values for extended periods may affect device reliability.

Application information — Applications that are described herein for any of these products are for illustrative purposes only. Philips Semiconductors make no representation or warranty that such applications will be suitable for the specified use without further testing or modification.

customers using or selling these products for use in such applications do so at their own risk and agree to fully indemnify Philips Semiconductors for any damages resulting from such application.

Right to make changes — Philips Semiconductors reserves the right to make changes in the products - including circuits, standard cells, and/or software - described or contained herein in order to improve design and/or performance. When the product is in full production (status 'Production'), relevant changes will be communicated via a Customer Product/Process Change Notification (CPCN). Philips Semiconductors assumes no responsibility or liability for the use of any of these products, conveys no licence or title under any patent, copyright, or mask work right to these products, and makes no representations or warranties that these products are free from patent, copyright, or mask work right infringement, unless otherwise specified.

20. Trademarks

Notice — All referenced brands, product names, service names and trademarks are the property of their respective owners.

19. Disclaimers

Life support — These products are not designed for use in life support appliances, devices, or systems where malfunction of these products can reasonably be expected to result in personal injury. Philips Semiconductors

21. Contact information

For additional information, please visit: <http://www.semiconductors.philips.com>

For sales office addresses, send an email to: sales.addresses@www.semiconductors.philips.com

22. Contents

| | | |
|-----|--------------------------------------------|----|
| 1 | General description | 1 |
| 2 | Features | 1 |
| 3 | Quick reference data | 2 |
| 4 | Ordering information | 2 |
| 5 | Marking | 3 |
| 6 | Functional diagram | 3 |
| 7 | Pinning information | 3 |
| 7.1 | Pinning | 3 |
| 7.2 | Pin description | 4 |
| 8 | Functional description | 4 |
| 8.1 | Function table | 4 |
| 9 | Limiting values | 5 |
| 10 | Recommended operating conditions | 5 |
| 11 | Static characteristics | 6 |
| 12 | Dynamic characteristics | 9 |
| 13 | Waveforms | 11 |
| 14 | Package outline | 13 |
| 15 | Abbreviations | 16 |
| 16 | Revision history | 16 |
| 17 | Data sheet status | 17 |
| 18 | Definitions | 17 |
| 19 | Disclaimers | 17 |
| 20 | Trademarks | 17 |
| 21 | Contact information | 17 |



© Koninklijke Philips Electronics N.V. 2005

All rights are reserved. Reproduction in whole or in part is prohibited without the prior written consent of the copyright owner. The information presented in this document does not form part of any quotation or contract, is believed to be accurate and reliable and may be changed without notice. No liability will be accepted by the publisher for any consequence of its use. Publication thereof does not convey nor imply any license under patent- or other industrial or intellectual property rights.

Date of release: 16 January 2006
Document number: 74AUP2G04_1

Published in The Netherlands

www.DataSheet4U.com