

DATA SHEET

74ALVCH16540

**2.5V/3.3V 16-bit buffer/line driver,
inverting, 5V input tolerant (3-State)**

Product specification
Supersedes data of 1996 Feb 07
IC24 Data Handbook

1997 Aug 11

16-bit buffer/line driver, inverting, 5V input tolerant (3-State)

74ALVCH16540

FEATURES

- Wide supply voltage range of 1.2 V to 3.6 V
- Complies with JEDEC standard no. 8-1A
- CMOS low power consumption
- MULTIBYTE™ flow-through standard pin-out architecture
- Low inductance multiple V_{CC} and ground pins for minimum noise and ground bounce
- Direct interface with TTL levels
- Bus hold on all data inputs eliminates the need for external pull-up resistors to hold unused inputs
- Output drive capability 50Ω transmission lines @ 85°C

DESCRIPTION

The 74ALVCH16540 is a high-performance, low-power, low-voltage, Si-gate CMOS device, superior to most advanced CMOS compatible TTL families.

The 74ALVCH16540 is a 16-bit inverting buffer/line driver with 3-State outputs. The 3-State outputs are controlled by the output enable inputs $1\overline{OE}_n$ and $2\overline{OE}_n$. A HIGH on $n\overline{OE}_n$ causes the outputs to assume a high impedance OFF-state.

Active bus hold circuitry is provided to hold unused or floating data inputs at a valid logic level. This feature eliminates the need for external pull-up or pull-down resistors. The device can be used as four 4-bit buffers, two 8-bit buffers or one 16-bit buffer.

PIN CONFIGURATION

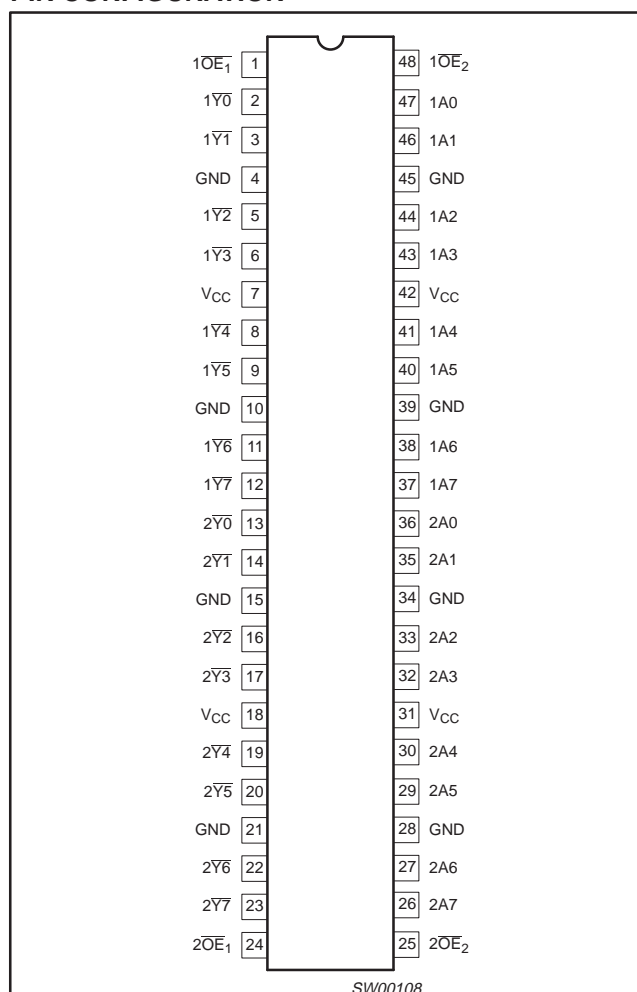

QUICK REFERENCE DATA

$GND = 0V$; $T_{amb} = 25^{\circ}C$; $t_r = t_f \leq 2.5ns$

SYMBOL	PARAMETER	CONDITIONS	TYPICAL	UNIT	
t_{PHL}/t_{PLH}	Propagation delay 1An to 1Yn; 2An to 2Yn	$C_L = 50pF$ $V_{CC} = 3.3V$	1.8	ns	
		$C_L = 30pF$ $V_{CC} = 2.5V$	1.8	ns	
C_I	Input capacitance		5.0	pF	
C_{PD}	Power dissipation capacitance per buffer	$V_I = GND$ to V_{CC}^1	Outputs enabled	26	pF
			Outputs disabled	5	pF

NOTES:

- C_{PD} is used to determine the dynamic power dissipation (P_D in μW):
 $P_D = C_{PD} \times V_{CC}^2 \times f_i + \sum (C_L \times V_{CC}^2 \times f_o)$ where:
 f_i = input frequency in MHz; C_L = output load capacitance in pF;
 f_o = output frequency in MHz; V_{CC} = supply voltage in V;
 $\sum (C_L \times V_{CC}^2 \times f_o)$ = sum of outputs.

ORDERING INFORMATION

PACKAGES	TEMPERATURE RANGE	OUTSIDE NORTH AMERICA	NORTH AMERICA	DWG NUMBER
48-Pin Plastic SSOP Type III	-40°C to +85°C	74ALVCH16540 DL	ACH16540 DL	SOT370-1
48-Pin Plastic TSSOP Type II	-40°C to +85°C	74ALVCH16540 DGG	ACH16540 DGG	SOT362-1

16-bit buffer/line driver, inverting, 5V input tolerant (3-State)

74ALVCH16540

PIN DESCRIPTION

PIN NUMBER	SYMBOL	NAME AND FUNCTION
1, 24	\overline{nOE}_1	Output enable input (active LOW)
2, 3, 5, 6, 8, 9, 11, 12	1Y0 to 1Y7	Data outputs
13, 14, 16, 17, 19, 20, 22, 23	2Y0 to 2Y7	
4, 10, 15, 21, 28, 34, 39, 45	GND	Ground (0V)
7, 18, 31, 42	V _{CC}	Positive supply voltage
25, 48	\overline{nOE}_2	Output enable input (active LOW)
36, 35, 33, 32, 30, 29, 27, 26	2A0 to 2A7	Data inputs
47, 46, 44, 43, 41, 40, 38, 37	1A0 to 1A7	

LOGIC SYMBOL (IEEE/IEC)

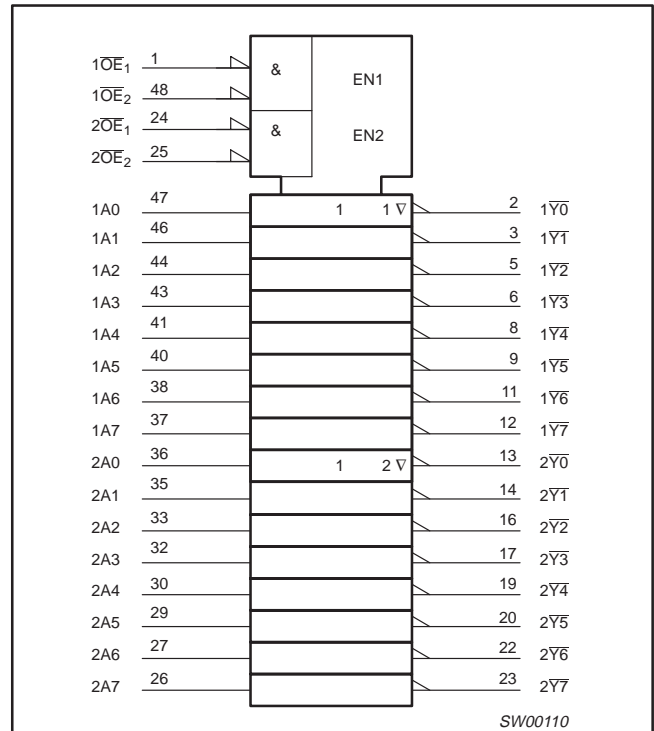

LOGIC SYMBOL

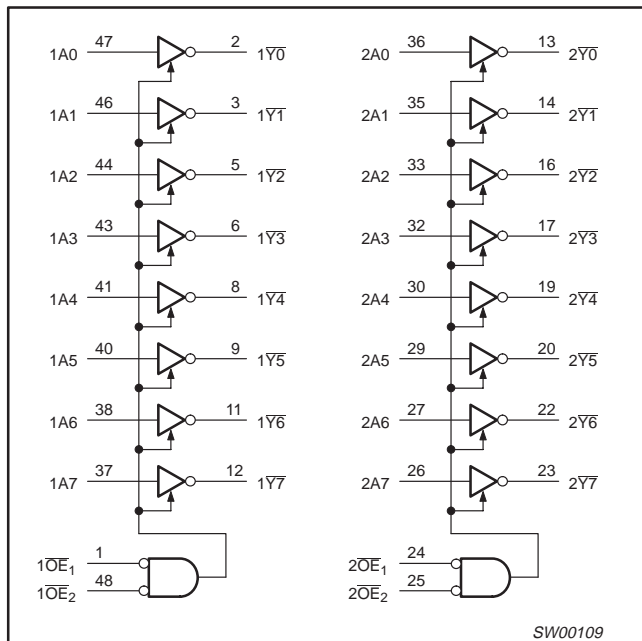

BUS HOLD CIRCUIT

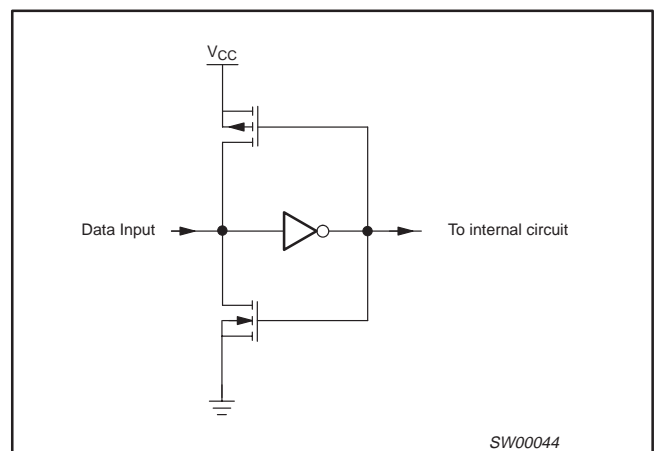

FUNCTION TABLE

INPUTS			OUTPUT
\overline{nOE}_1	\overline{nOE}_2	nAn	nYn
L	L	L	H
L	L	H	L
X	H	X	Z
H	X	X	Z

H = HIGH voltage level
 L = LOW voltage level
 X = don't care
 Z = high impedance OFF-state

16-bit buffer/line driver, inverting, 5V input tolerant (3-State)

74ALVCH16540

RECOMMENDED OPERATING CONDITIONS

SYMBOL	PARAMETER	CONDITIONS	LIMITS		UNIT
			MIN	MAX	
V_{CC}	DC supply voltage 2.5V range (for max. speed performance)		2.3	2.7	V
	DC supply voltage 3.3V range (for max. speed performance)		3.0	3.6	
	DC supply voltage (for low-voltage applications)		1.2	3.6	
V_I	DC Input voltage range	For data input pins	0	V_{CC}	V
	DC Input voltage range	For control pins	0	5.5	
V_O	DC output voltage range		0	V_{CC}	V
T_{amb}	Operating free-air temperature range		-40	+85	°C
t_r, t_f	Input rise and fall times	$V_{CC} = 2.3$ to $3.0V$ $V_{CC} = 3.0$ to $3.6V$	0 0	20 10	ns/V

ABSOLUTE MAXIMUM RATINGS^{1, 2}

In accordance with the Absolute Maximum Rating System (IEC 134)

Voltages are referenced to GND (ground = 0V)

SYMBOL	PARAMETER	CONDITIONS	RATING	UNIT
V_{CC}	DC supply voltage		-0.5 to +4.6	V
I_{IK}	DC input diode current	$V_I < 0$	-50	mA
V_I	DC input voltage	For control pins and data inputs of ALVC parts ²	-0.5 to +5.5	V
		For data inputs of ALVCH parts ²	-0.5 to $V_{CC} + 0.5$	
I_{OK}	DC output diode current	$V_O > V_{CC}$ or $V_O < 0$	± 50	mA
V_O	DC output voltage	Note 2	-0.5 to $V_{CC} + 0.5$	V
I_O	DC output source or sink current	$V_O = 0$ to V_{CC}	± 50	mA
I_{GND}, I_{CC}	DC V_{CC} or GND current		± 100	mA
T_{stg}	Storage temperature range		-65 to +150	°C
P_{TOT}	Power dissipation per package -plastic medium-shrink SO (SSOP) -plastic mini-pack (TSSOP)	For temperature range: -40 to +125 °C above +55°C derate linearly with 11.3 mW/K above +55°C derate linearly with 8 mW/K	850	mW
			600	

NOTES:

- Stresses beyond those listed may cause permanent damage to the device. These are stress ratings only and functional operation of the device at these or any other conditions beyond those indicated under "recommended operating conditions" is not implied. Exposure to absolute-maximum-rated conditions for extended periods may affect device reliability.
- The input and output voltage ratings may be exceeded if the input and output current ratings are observed.

16-bit buffer/line driver, inverting, 5V input tolerant (3-State)

74ALVCH16540

DC ELECTRICAL CHARACTERISTICS

SYMBOL	PARAMETER	TEST CONDITIONS	LIMITS			UNIT
			Temp = -40°C to +85°C			
			MIN	TYP ¹	MAX	
V _{IH}	HIGH level Input voltage	V _{CC} = 1.2V	V _{CC}			V
		V _{CC} = 2.3 to 2.7V	1.7			
		V _{CC} = 2.7 to 3.6V	2.0			
V _{IL}	LOW level Input voltage	V _{CC} = 1.2V			GND	V
		V _{CC} = 2.3 to 2.7V			0.7	
		V _{CC} = 2.7 to 3.6V			0.8	
V _{OH}	HIGH level output voltage	V _{CC} = 2.3V; V _I = V _{IH} or V _{IL} ; I _O = -1mA	V _{CC} - 0.3			V
		V _{CC} = 2.3V; V _I = V _{IH} or V _{IL} ; I _O = -8mA	V _{CC} - 0.5			
		V _{CC} = 2.7V; V _I = V _{IH} or V _{IL} ; I _O = -12mA	V _{CC} - 0.5			
		V _{CC} = 2.3/3.0V; V _I = V _{IH} or V _{IL} ; I _O = -100μA	V _{CC} - 0.2	V _{CC}		
		V _{CC} = 3.0V; V _I = V _{IH} or V _{IL} ; I _O = -24mA	V _{CC} - 1.0			
V _{OL}	LOW level output voltage	V _{CC} = 2.3V; V _I = V _{IH} or V _{IL} ; I _O = 1mA			0.40	V
		V _{CC} = 2.3V; V _I = V _{IH} or V _{IL} ; I _O = 8mA			0.60	
		V _{CC} = 2.7V; V _I = V _{IH} or V _{IL} ; I _O = 12mA			0.40	
		V _{CC} = 2.3/3.0V; V _I = V _{IH} or V _{IL} ; I _O = 100μA			0.20	
		V _{CC} = 3.0V; V _I = V _{IH} or V _{IL} ; I _O = 24mA			0.55	
I _I	Input leakage current	V _{CC} = 3.6V; V _I = 5.5V or GND	Control pins	± 0.1	± 5	μA
		V _{CC} = 3.6V; V _I = V _{CC} or GND	Data input pins	± 0.1	± 5	
I _{IHZ} /I _{ILZ}	Input current for common I/O pins	V _{CC} = 3.6V; V _I = V _{CC} or GND		± 0.1	± 15	μA
I _{OZ}	3-State output OFF-state current	V _{CC} = 3.6V; V _I = V _{IH} or V _{IL} ; V _O = V _{CC} or GND		0.1	± 10	μA
	3-State output OFF-state current	V _{CC} = 2.7V; V _I = V _{IH} or V _{IL} ; V _O = V _{CC} or GND		0.1	± 5	
I _{CC}	Quiescent supply current	V _{CC} = 3.6V; V _I = V _{CC} or GND; I _O = 0		0.2	40	μA
	Quiescent supply current	V _{CC} = 2.7V; V _I = V _{CC} or GND; I _O = 0		0.2	20	
ΔI _{CC}	Additional quiescent supply current per control pin	V _{CC} = 2.7V to 3.6V; V _I = V _{CC} - 0.6V; I _O = 0		5	500	μA
	Additional quiescent supply current per data I/O pin	V _{CC} = 2.7V to 3.6V; V _I = V _{CC} - 0.6V; I _O = 0		150	750	
IBHL	Bus hold LOW sustaining current	V _{CC} = 2.3V; V _I = 0.7V	45			μA
		V _{CC} = 3.0V; V _I = 0.8V	75			
IBHH	Bus hold HIGH sustaining current	V _{CC} = 2.3V; V _I = 1.7V	-45			μA
		V _{CC} = 3.0V; V _I = 2.0V	-75			
IBHLO	Bus hold LOW overdrive current	V _{CC} = 2.7V	300			μA
		V _{CC} = 3.6V	450			
IBHHO	Bus hold HIGH overdrive current	V _{CC} = 2.7V	-300			μA
		V _{CC} = 3.6V	-450			

NOTES:

1. All typical values are at V_{CC} = 3.3V and T_{amb} = 25°C.

16-bit buffer/line driver, inverting, 5V input tolerant (3-State)

74ALVCH16540

AC CHARACTERISTICS FOR $V_{CC} = 3.0V$ TO $3.6V$ RANGE AND $V_{CC} = 2.7V$

$GND = 0V$; $t_r = t_f \leq 2.5ns$; $C_L = 50pF$

SYMBOL	PARAMETER	WAVEFORM	LIMITS					UNIT
			$V_{CC} = 3.0 \pm 0.3V$			$V_{CC} = 2.7V$		
			MIN	TYP ¹	MAX	TYP	MAX	
t_{PHL}/t_{PLH}	Propagation delay 1An to 1Yn; 2An to 2Yn	4		1.8	3.0	2.1	3.6	ns
t_{PZH}/t_{PZL}	3-State output enable time 1OEn to 1Yn; 2OEn to 2Yn	5, 6		2.1	3.8	2.9	4.7	ns
t_{PHZ}/t_{PLZ}	3-State output disable time 1OEn to 1Yn; 2OEn to 2Yn	5, 6		2.7	4.1	3.2	4.5	ns

NOTE:

1. All typical values are at $V_{CC} = 3.3V$ and $T_{amb} = 25^\circ C$.

AC CHARACTERISTICS FOR $V_{CC} = 2.3V$ TO $2.7V$ RANGE AND $V_{CC} < 2.3V$

$GND = 0V$; $t_r = t_f \leq 2.0ns$; $C_L = 30pF$

SYMBOL	PARAMETER	WAVEFORM	LIMITS					UNIT
			$V_{CC} = 2.3$ to $2.7V$			$V_{CC} = 1.8V$	$V_{CC} = 1.2V$	
			MIN	TYP ¹	MAX	TYP	MAX	
t_{PHL}/t_{PLH}	Propagation delay 1An to 1Yn; 2An to 2Yn	4		1.8	3.2	3.1	6.0	ns
t_{PZH}/t_{PZL}	3-State output enable time 1OEn to 1Yn; 2OEn to 2Yn	5, 6		2.5	4.4	4.3	8.9	ns
t_{PHZ}/t_{PLZ}	3-State output disable time 1OEn to 1Yn; 2OEn to 2Yn	5, 6		2.2	3.8	3.6	6.4	ns

NOTE:

1. All typical values are at $V_{CC} = 2.5V$ and $T_{amb} = 25^\circ C$.

AC WAVEFORMS FOR $V_{CC} = 3.0V$ TO $3.6V$ AND $V_{CC} = 2.7V$ RANGE

$V_M = 1.5V$

$V_X = V_{OL} + 0.3V$

$V_Y = V_{OH} - 0.3V$

V_{OL} and V_{OH} are the typical output voltage drop that occur with the output load.

$V_I = 2.7V$

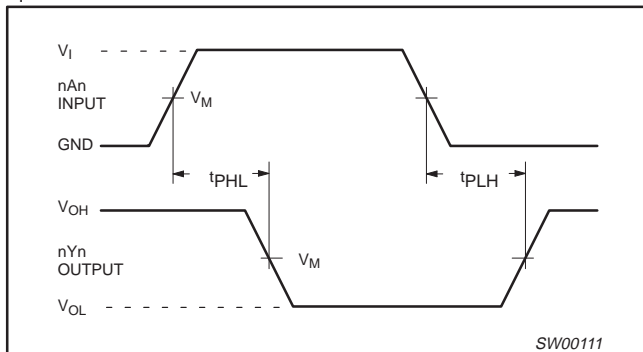

Waveform 1. Input (An) to output (Yn) propagation delay times

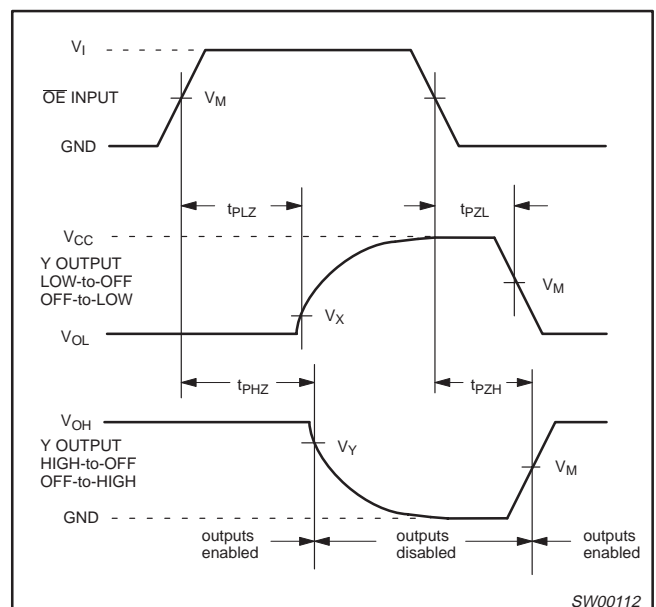

Waveform 2. 3-State enable and disable times

16-bit buffer/line driver, inverting, 5V input tolerant (3-State)

74ALVCH16540

TEST CIRCUIT

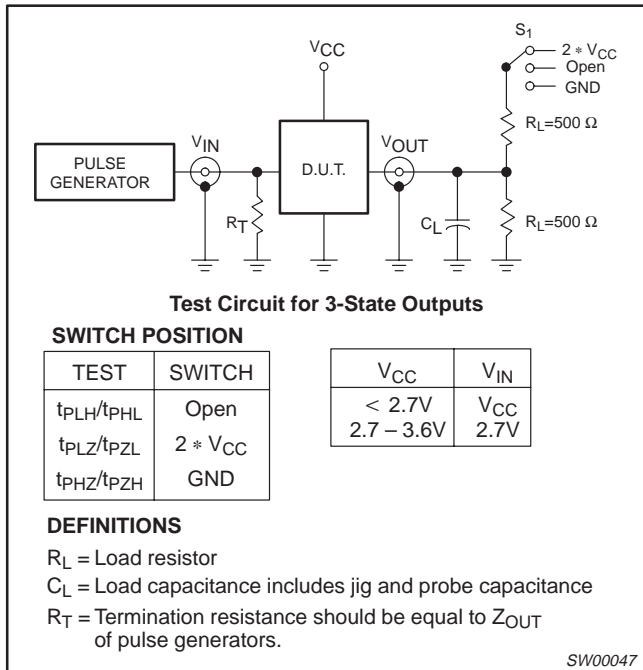

Waveform 3. Load circuitry for switching times

AC WAVEFORMS FOR $V_{CC} = 2.3V$ TO $2.7V$ AND $V_{CC} < 2.3V$ RANGE

$V_M = 0.5 * V_{CC}$
 $V_X = V_{OL} + 0.15V$
 $V_Y = V_{OH} - 0.15V$
 V_{OL} and V_{OH} are the typical output voltage drop that occur with the output load.
 $V_I = V_{CC}$

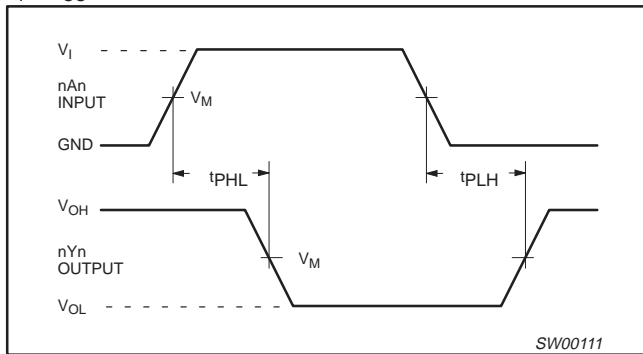

Waveform 4. Input (An) to output (Yn) propagation delay times

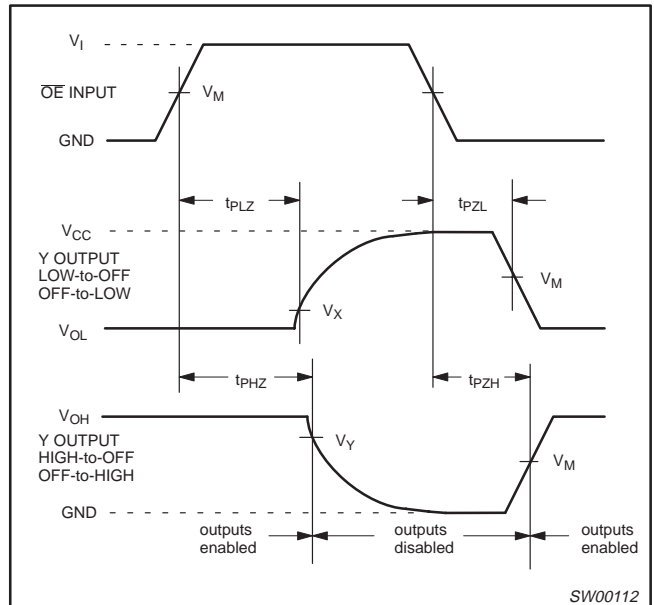

Waveform 5. 3-State enable and disable times

16-bit buffer/line driver, inverting, 5V input tolerant (3-State)

74ALVCH16540

TEST CIRCUIT

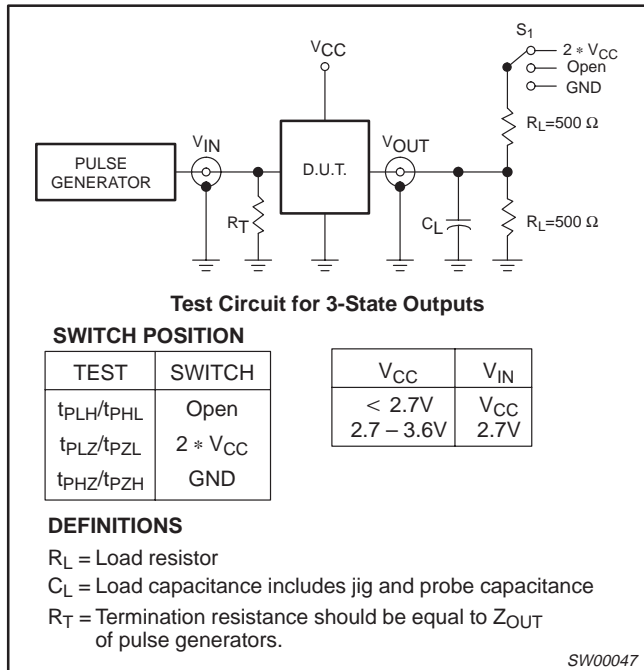

Waveform 6. Load circuitry for switching times

2.5V/3.3V 16-bit buffer/line driver, inverting,
5V input tolerant (3-State)

74ALVCH16540

SSOP48: plastic shrink small outline package; 48 leads; body width 7.5 mm

SOT370-1

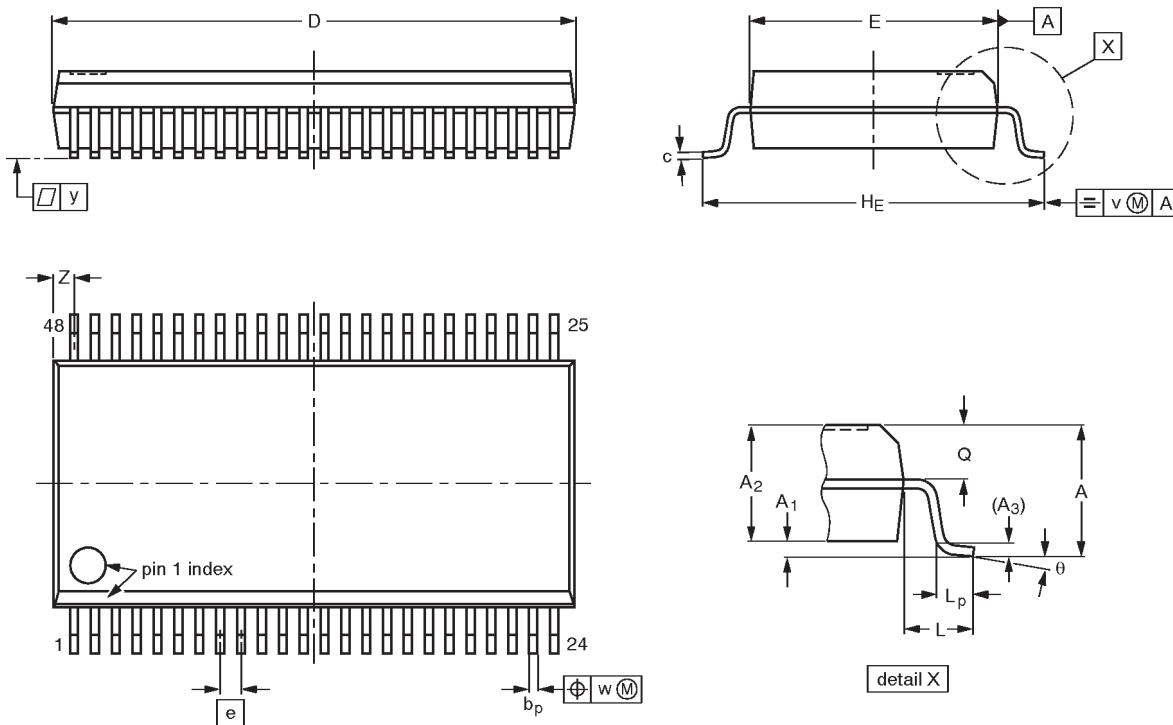

DIMENSIONS (mm are the original dimensions)

UNIT	A max.	A ₁	A ₂	A ₃	b _p	c	D ⁽¹⁾	E ⁽¹⁾	e	H _E	L	L _p	Q	v	w	y	Z ⁽¹⁾	θ
mm	2.8	0.4 0.2	2.35 2.20	0.25	0.3 0.2	0.22 0.13	16.00 15.75	7.6 7.4	0.635	10.4 10.1	1.4	1.0 0.6	1.2 1.0	0.25	0.18	0.1	0.85 0.40	8° 0°

Note

1. Plastic or metal protrusions of 0.25 mm maximum per side are not included.

OUTLINE VERSION	REFERENCES				EUROPEAN PROJECTION	ISSUE DATE
	IEC	JEDEC	EIAJ			
SOT370-1		MO-118AA				93-11-02- 95-02-04

2.5V/3.3V 16-bit buffer/line driver, inverting,
5V input tolerant (3-State)

74ALVCH16540

TSSOP48: plastic thin shrink small outline package; 48 leads; body width 6.1mm

SOT362-1

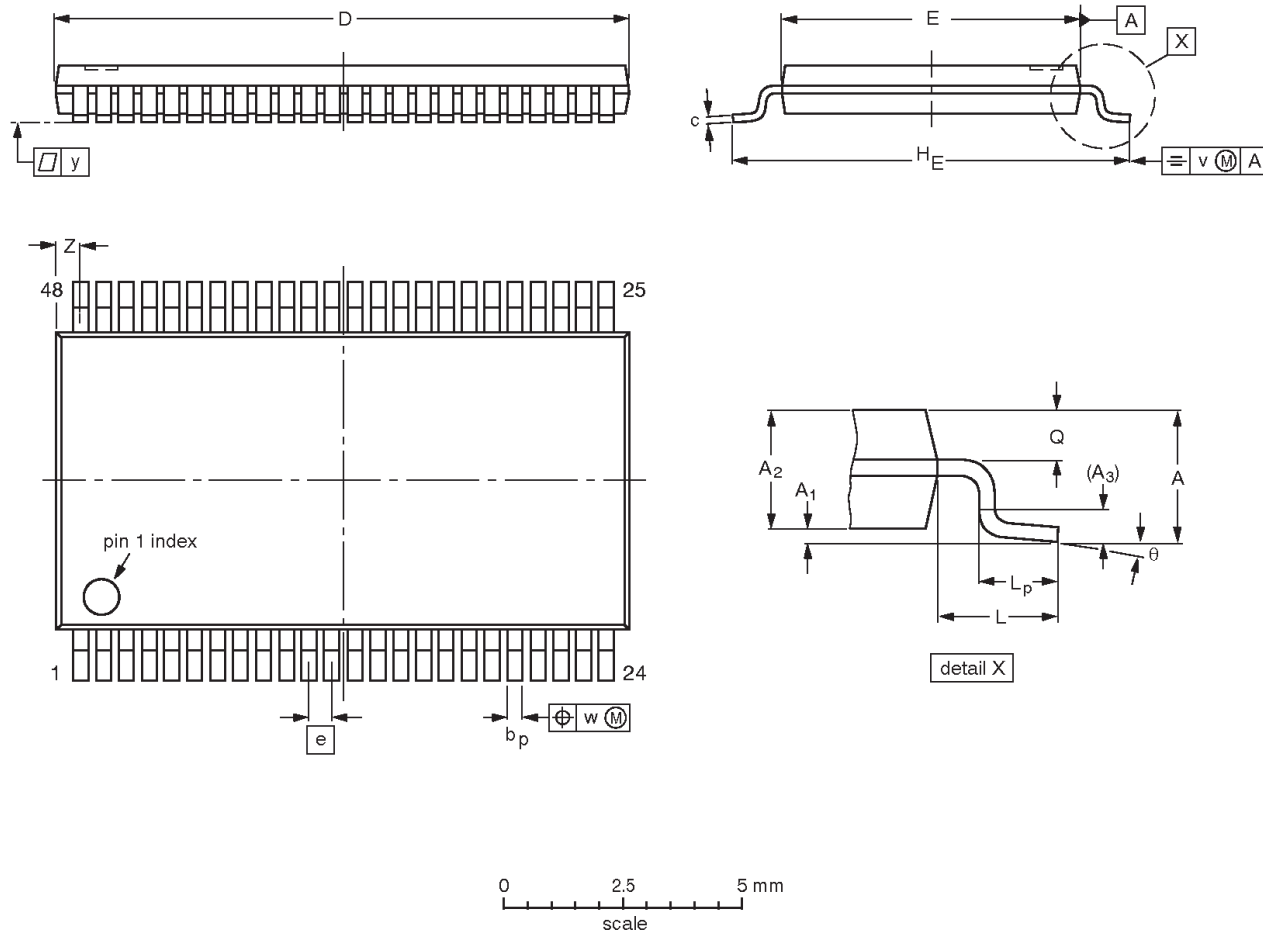

DIMENSIONS (mm are the original dimensions).

UNIT	A max.	A ₁	A ₂	A ₃	b _p	c	D ⁽¹⁾	E ⁽²⁾	e	H _E	L	L _p	Q	v	w	y	Z	θ
mm	1.2	0.15 0.05	1.05 0.85	0.25	0.28 0.17	0.2 0.1	12.6 12.4	6.2 6.0	0.5	8.3 7.9	1	0.8 0.4	0.50 0.35	0.25	0.08	0.1	0.8 0.4	8° 0°

Notes

1. Plastic or metal protrusions of 0.15 mm maximum per side are not included.
2. Plastic interlead protrusions of 0.25 mm maximum per side are not included.

OUTLINE VERSION	REFERENCES				EUROPEAN PROJECTION	ISSUE DATE
	IEC	JEDEC	EIAJ			
SOT362-1		MO-153ED				93-02-03 95-02-10

2.5V/3.3V 16-bit buffer/line driver, inverting,
5V input tolerant (3-State)

74ALVCH16540

NOTES

2.5V/3.3V 16-bit buffer/line driver, inverting, 5V input tolerant (3-State)

74ALVCH16540

DEFINITIONS

Data Sheet Identification	Product Status	Definition
<i>Objective Specification</i>	Formative or in Design	This data sheet contains the design target or goal specifications for product development. Specifications may change in any manner without notice.
<i>Preliminary Specification</i>	Preproduction Product	This data sheet contains preliminary data, and supplementary data will be published at a later date. Philips Semiconductors reserves the right to make changes at any time without notice in order to improve design and supply the best possible product.
<i>Product Specification</i>	Full Production	This data sheet contains Final Specifications. Philips Semiconductors reserves the right to make changes at any time without notice, in order to improve design and supply the best possible product.

Philips Semiconductors and Philips Electronics North America Corporation reserve the right to make changes, without notice, in the products, including circuits, standard cells, and/or software, described or contained herein in order to improve design and/or performance. Philips Semiconductors assumes no responsibility or liability for the use of any of these products, conveys no license or title under any patent, copyright, or mask work right to these products, and makes no representations or warranties that these products are free from patent, copyright, or mask work right infringement, unless otherwise specified. Applications that are described herein for any of these products are for illustrative purposes only. Philips Semiconductors makes no representation or warranty that such applications will be suitable for the specified use without further testing or modification.

LIFE SUPPORT APPLICATIONS

Philips Semiconductors and Philips Electronics North America Corporation Products are not designed for use in life support appliances, devices, or systems where malfunction of a Philips Semiconductors and Philips Electronics North America Corporation Product can reasonably be expected to result in a personal injury. Philips Semiconductors and Philips Electronics North America Corporation customers using or selling Philips Semiconductors and Philips Electronics North America Corporation Products for use in such applications do so at their own risk and agree to fully indemnify Philips Semiconductors and Philips Electronics North America Corporation for any damages resulting from such improper use or sale.

Philips Semiconductors
811 East Arques Avenue
P.O. Box 3409
Sunnyvale, California 94088-3409
Telephone 800-234-7381

© Copyright Philips Electronics North America Corporation 1998
 All rights reserved. Printed in U.S.A.

Date of release: 08-97

Document order number:

9397-750-04545

Let's make things better.

Philips
Semiconductors



PHILIPS