

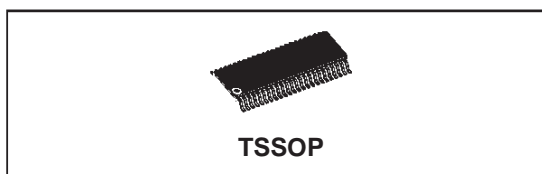

74ACT16244

16-BIT BUS BUFFER WITH 3 STATE OUTPUTS (NON INVERTED)

- HIGH SPEED: $t_{PD} = 4.8 \text{ ns}$ (TYP.) at $V_{CC} = 5V$
- LOW POWER DISSIPATION:
 $I_{CC} = 8 \mu\text{A}$ (MAX.) at $T_A = 25 \text{ }^\circ\text{C}$
- COMPATIBLE WITH TTL OUTPUTS
 $V_{IH} = 2V$ (MIN), $V_{IL} = 0.8V$ (MAX)
- 50Ω TRANSMISSION LINE DRIVING CAPABILITY
- SYMMETRICAL OUTPUT IMPEDANCE:
 $|I_{OH}| = I_{OL} = 24 \text{ mA}$ (MIN)
- BALANCED PROPAGATION DELAYS:
 $t_{PLH} \cong t_{PHL}$
- OPERATING VOLTAGE RANGE:
 V_{CC} (OPR) = 4.5V to 5.5V
- IMPROVED LATCH-UP IMMUNITY



ORDER CODES		
PACKAGE	TUBE	T & R
TSSOP		74ACT16244TTR

DESCRIPTION

The ACT16244 is an advanced CMOS 16-BIT BUS BUFFER (3-STATE) fabricated with sub-micron silicon gate and double-layer metal wiring C²MOS technology.

\overline{G} output control governs four BUS BUFFERS.

The device is designed to be used with 3-state memory address drivers, clock drivers, and bus-oriented receivers and transmitters. The device can be used as four 4-bit buffers, two 8-bit buffers, or one 16-bit buffer.

The device is designed to interface directly High Speed CMOS systems with TTL, NMOS and CMOS output voltage levels.

All inputs and outputs are equipped with protection circuits against static discharge, giving them 2KV ESD immunity and transient excess voltage.

PIN CONNECTION

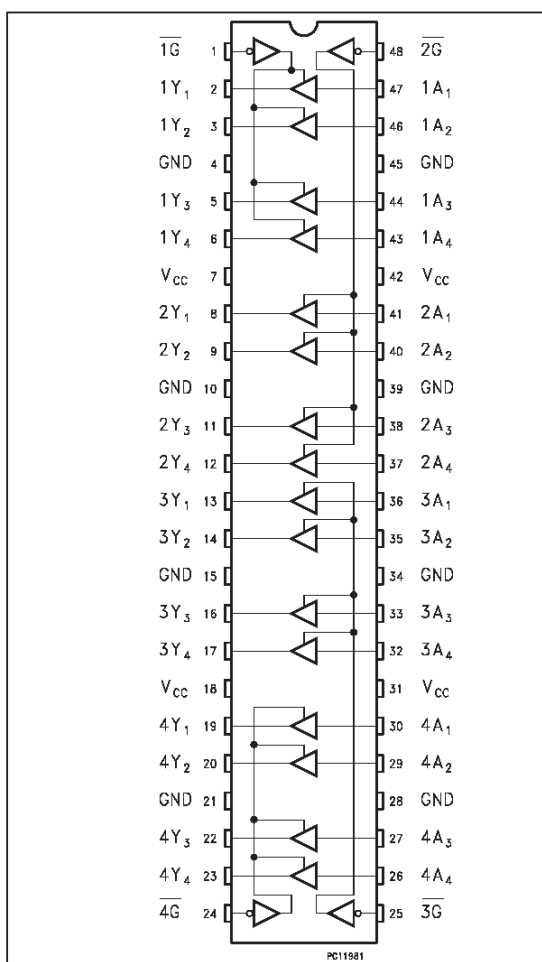

INPUT AND OUTPUT EQUIVALENT CIRCUIT

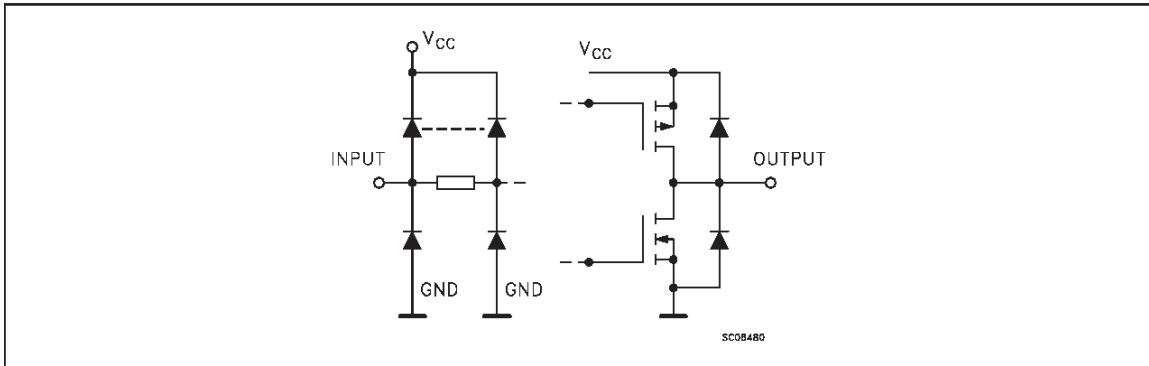

PIN DESCRIPTION

PIN No	SYMBOL	NAME AND FUNCTION
1	$\overline{1G}$	Output Enable Input
2, 3, 5, 6	1Y1 to 1Y4	Data Outputs
8, 9, 11, 12	2Y1 to 2Y4	Data Outputs
13, 14, 16, 17	3Y1 to 3Y4	Data Outputs
19, 20, 22, 23	4Y1 to 4Y4	Data Outputs
24	$\overline{4G}$	Output Enable Input
25	$\overline{3G}$	Output Enable Input
30, 29, 27, 26	4A1 to 4A4	Data Inputs
36, 35, 33, 32	3A1 to 3A4	Data Inputs
41, 40, 38, 37	2A1 to 2A4	Data Inputs
47, 46, 44, 43	1A1 to 1A4	Data Inputs
48	$\overline{2G}$	Output Enable Input
4, 10, 15, 21, 28, 34, 39, 45	GND	Ground (0V)
7, 18, 31, 42	Vcc	Positive Supply Voltage

IEC LOGIC SYMBOLS

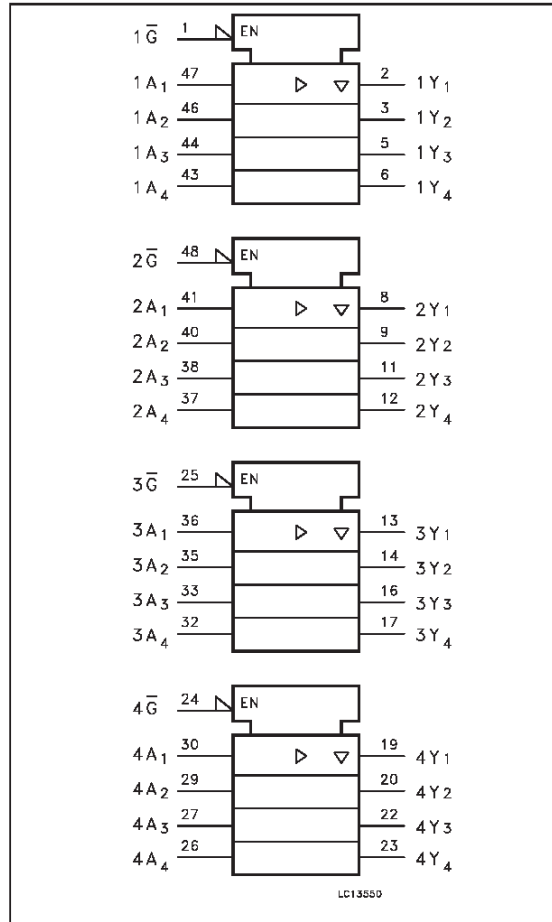

TRUTH TABLE

INPUT		OUTPUT
\overline{G}	A _n	Y _n
L	L	L
L	H	H
H	X	Z

X: "H" or "L"
Z: High impedance

ABSOLUTE MAXIMUM RATINGS

Symbol	Parameter	Value	Unit
V_{CC}	Supply Voltage	-0.5 to +7	V
V_I	DC Input Voltage	-0.5 to $V_{CC} + 0.5$	V
V_O	DC Output Voltage	-0.5 to $V_{CC} + 0.5$	V
I_{IK}	DC Input Diode Current	± 20	mA
I_{OK}	DC Output Diode Current	± 20	mA
I_O	DC Output Current	± 50	mA
I_{CC} or I_{GND}	DC V_{CC} or Ground Current	± 400	mA
T_{stg}	Storage Temperature	-65 to +150	°C
T_L	Lead Temperature (10 sec)	300	°C

Absolute Maximum Ratings are those values beyond which damage to the device may occur. Functional operation under these condition is not implied.

RECOMMENDED OPERATING CONDITIONS

Symbol	Parameter	Value	Unit
V_{CC}	Supply Voltage	4.5 to 5.5	V
V_I	Input Voltage	0 to V_{CC}	V
V_O	Output Voltage	0 to V_{CC}	V
T_{op}	Operating Temperature:	-40 to +85	°C
dt/dv	Input Rise and Fall Time $V_{CC} = 4.5$ to 5.5 V (note 1)	8	ns/V

1) V_{IN} from 0.8V to 2.0V

DC SPECIFICATIONS

Symbol	Parameter	Test Conditions		Value					Unit
				T _A = 25 °C			-40 to 85 °C		
				V _{CC} (V)	Min.	Typ.	Max.	Min.	
V _{IH}	High Level Input Voltage	4.5	V _O = 0.1 V or V _{CC} - 0.1 V	2.0			2.0		V
		5.5		2.0			2.0		
V _{IL}	Low Level Input Voltage	4.5	V _O = 0.1 V or V _{CC} - 0.1 V			0.8		0.8	V
		5.5				0.8		0.8	
V _{OH}	High Level Output Voltage	4.5	I _O = -50 μA	4.4	4.49		4.4		V
		5.5	I _O = -50 μA	5.4	5.49		5.4		
		4.5	I _O = -24 mA	3.94			3.8		
		5.5	I _O = -24 mA	4.94			4.8		
V _{OL}	Low Level Output Voltage	4.5	I _O = 50 μA		0.001	0.1		0.1	V
		5.5	I _O = 50 mA		0.001	0.1		0.1	
		4.5	I _O = 24 mA			0.36		0.44	
		5.5	I _O = 24 mA			0.36		0.44	
I _I	Input Leakage Current	5.5	V _I = V _{CC} or GND			±0.1		±1	μA
I _{OZ}	High Impedance Output Leakage Current	5.5	V _I = V _{IH} or V _{IL} V _O = V _{CC} or GND			±0.5		±5	μA
I _{CCR}	Max I _{CC} /Input	5.5	V _I = V _{CC} - 2.1 V			0.9		1	mA
I _{CC}	Quiescent Supply Current	5.5	V _I = V _{CC} or GND			8		80	μA
I _{OLD}	Dynamic Output Current (note 1, 2)	5.5	V _{OLD} = 1.65 V max				75		mA
I _{OHD}			V _{OHD} = 3.85 V min				-75		mA

1) Maximum test duration 2ms, one output loaded at time

2) Incident wave switching is guaranteed on transmission lines with impedances as low as 50 Ω.

AC ELECTRICAL CHARACTERISTICS ($C_L = 50 \text{ pF}$, $R_L = 500 \Omega$, Input $t_r = t_f = 3 \text{ ns}$)

Symbol	Parameter	Test Condition		Value					Unit
				T _A = 25 °C			-40 to 85 °C		
				V _{CC} (V)	Min.	Typ.	Max.	Min.	
t _{PLH} t _{PHL}	Propagation Delay Time	5.0 ^(*)	2.0	3.3	5.0	2.0	6.0	ns	
			3.0	4.8	6.5	3.0	8.0		
t _{PZL} t _{PZH}	Output Enable Time	5.0 ^(*)	4.0	6.5	8.7	4.0	9.7	ns	
			3.0	5.5	7.7	3.0	8.8		
t _{PLZ} t _{PHZ}	Output Disable Time	5.0 ^(*)	4.0	6.0	8.0	4.0	9.2	ns	
			3.0	4.6	6.4	3.0	7.3		

(*) Voltage range is $5\text{V} \pm 0.5\text{V}$ **CAPACITIVE CHARACTERISTICS**

Symbol	Parameter	Test Conditions		Value					Unit
				T _A = 25 °C			-40 to 85 °C		
				V _{CC} (V)	Min.	Typ.	Max.	Min.	
C _{IN}	Input Capacitance	5.0		3.6					pF
C _{OUT}	Output Capacitance	5.0		11					pF
C _{PD}	Power Dissipation Capacitance (note 1)	5.0		42					pF

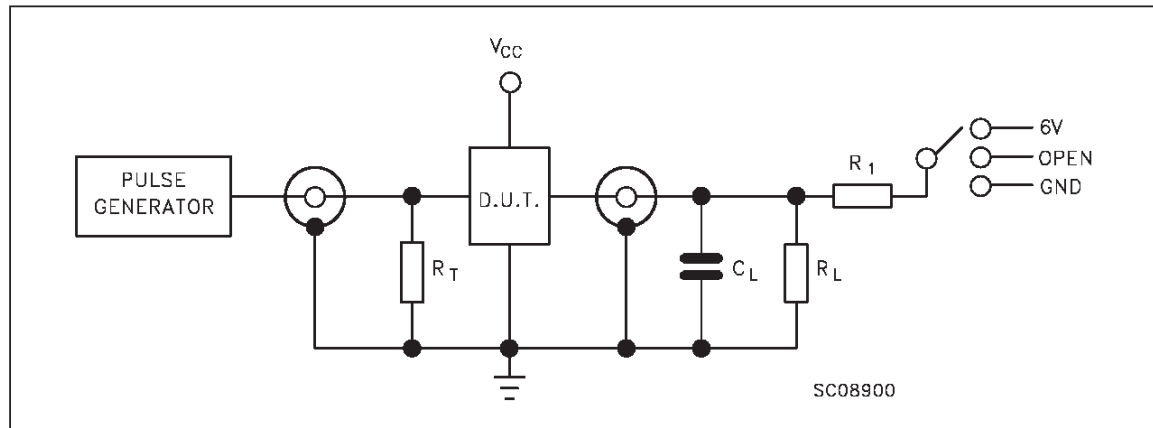
1) C_{PD} is defined as the value of the IC's internal equivalent capacitance which is calculated from the operating current consumption without load. (Refer to Test Circuit). Average operating current can be obtained by the following equation. $I_{CC(opr)} = C_{PD} \cdot V_{CC} \cdot f_{IN} + I_{CC}/16$ (per circuit)**TEST CIRCUIT**

TEST	SWITCH
t _{PLH} , t _{PHL}	Open
t _{PZL} , t _{PLZ}	2V _{CC}
t _{PZH} , t _{PHZ}	GND

C_L = 50 pF or equivalent (includes jig and probe capacitance)R_L = R₁ = 500Ω or equivalentR_T = Z_{OUT} of pulse generator (typically 50Ω)

WAVEFORM 1: PROPAGATION DELAYS (f=1MHz; 50% duty cycle)

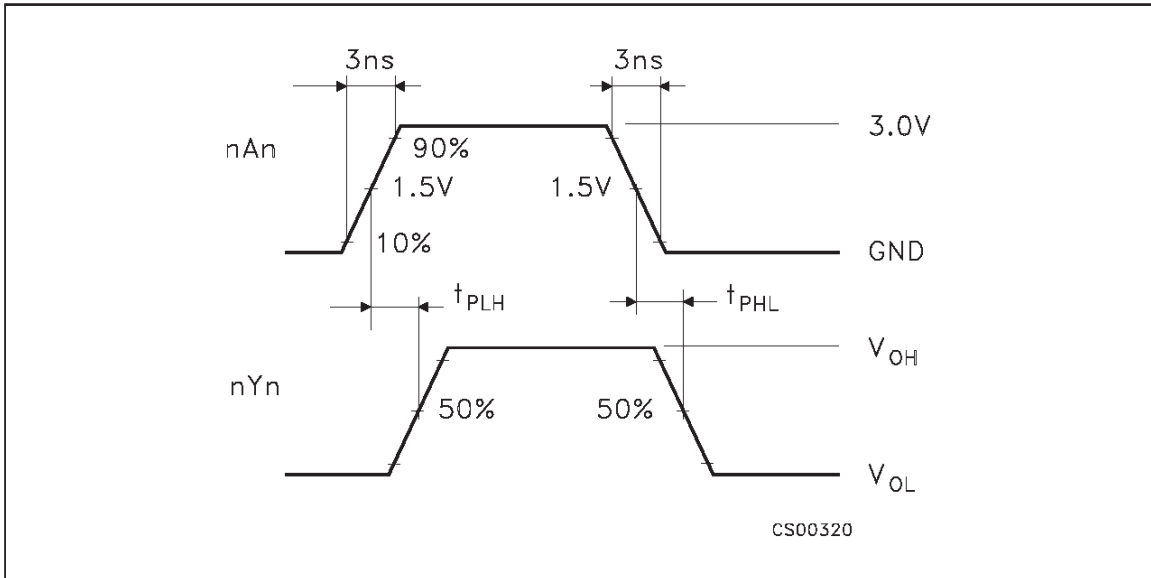

WAVEFORM 2: OUTPUT ENABLE AND DISABLE TIME (f=1MHz; 50% duty cycle)

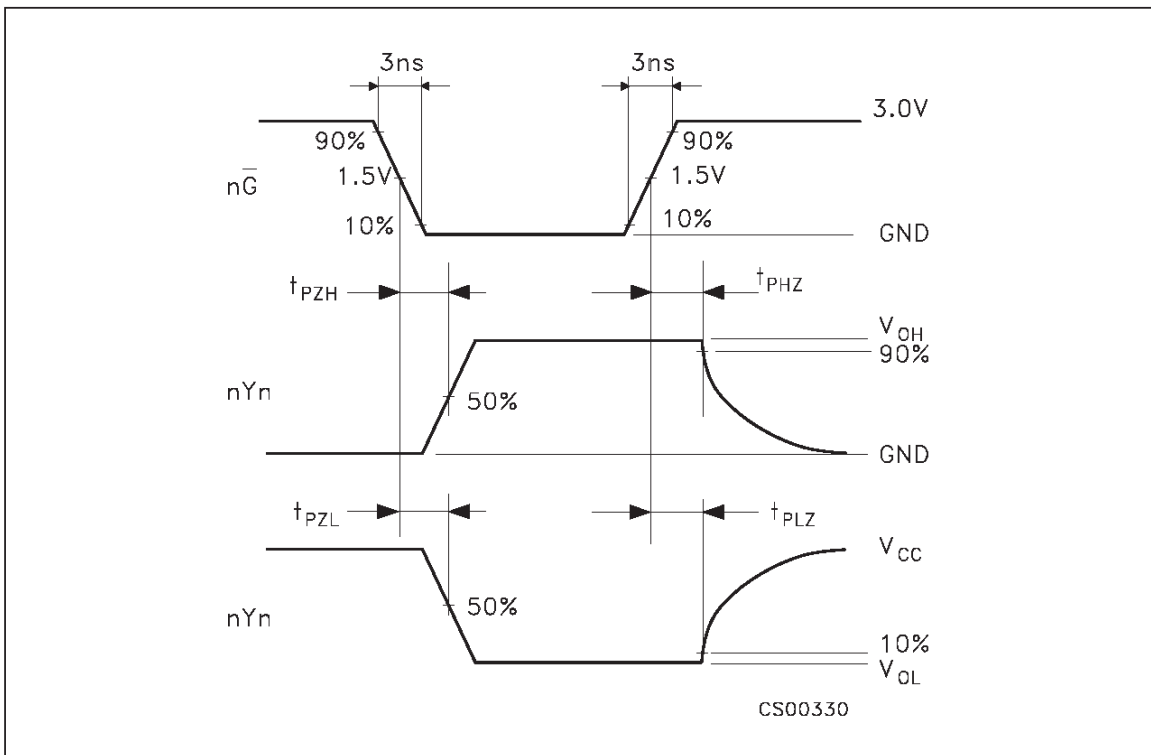

TSSOP48 MECHANICAL DATA

DIM.	mm			inch		
	MIN.	TYP.	MAX.	MIN.	TYP.	MAX.
A			1.1			0.433
A1	0.05	0.10	0.15	0.002	0.004	0.006
A2	0.85	0.9	0.95	0.335	0.354	0.374
b	0.17		0.27	0.0067		0.011
c	0.09		0.20	0.0035		0.0079
D	12.4	12.5	12.6	0.408	0.492	0.496
E	7.95	8.1	8.25	0.313	0.319	0.325
E1	6.0	6.1	6.2	0.236	0.240	0.244
e		0.5 BSC			0.0197 BSC	
K	0°	4°	8°	0°	4°	8°
L	0.50	0.60	0.70	0.020	0.024	0.028

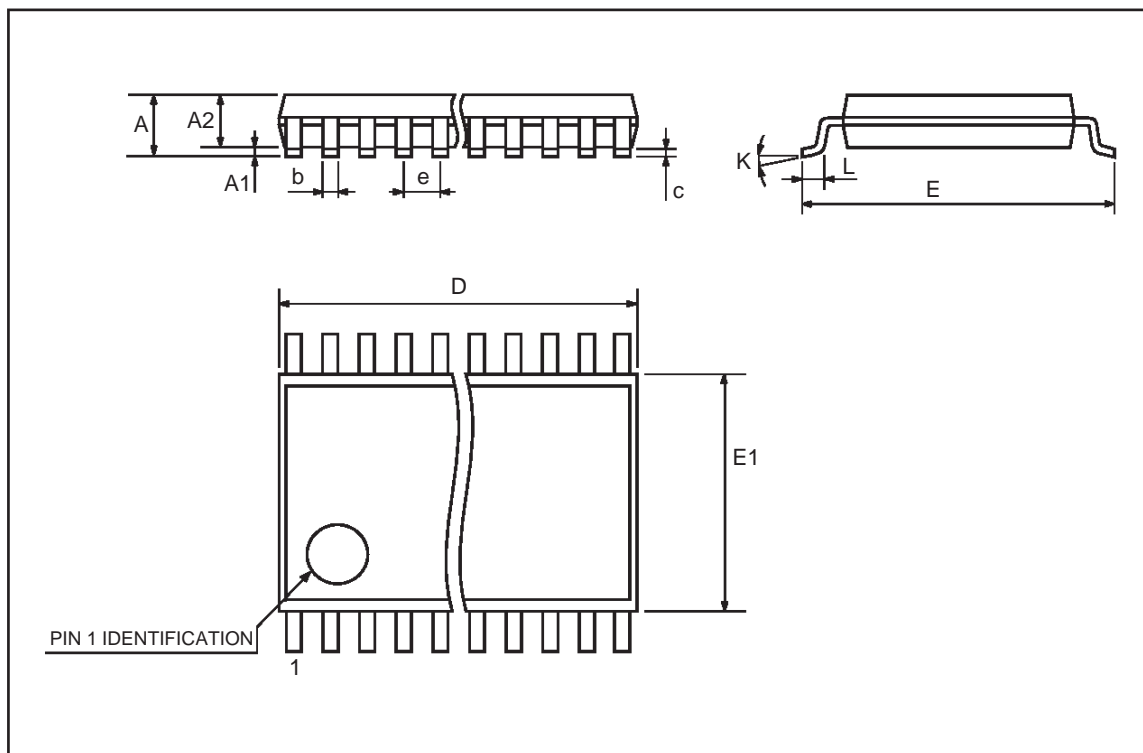

Information furnished is believed to be accurate and reliable. However, STMicroelectronics assumes no responsibility for the consequences of use of such information nor for any infringement of patents or other rights of third parties which may result from its use. No license is granted by implication or otherwise under any patent or patent rights of STMicroelectronics. Specification mentioned in this publication are subject to change without notice. This publication supersedes and replaces all information previously supplied. STMicroelectronics products are not authorized for use as critical components in life support devices or systems without express written approval of STMicroelectronics.

The ST logo is a registered trademark of STMicroelectronics

© 2000 STMicroelectronics – Printed in Italy – All Rights Reserved

STMicroelectronics GROUP OF COMPANIES

Australia - Brazil - China - Finland - France - Germany - Hong Kong - India - Italy - Japan - Malaysia - Malta - Morocco
Singapore - Spain - Sweden - Switzerland - United Kingdom - U.S.A.

<http://www.st.com>