

QUAD 2 CHANNEL MULTIPLEXER (INV.)

- HIGH SPEED: $t_{PD} = 4 \text{ ns}$ (TYP.) at $V_{CC} = 5V$
- LOW POWER DISSIPATION:
 $I_{CC} = 8 \mu A$ (MAX.) at $T_A = 25^\circ C$
- COMPATIBLE WITH TTL OUTPUTS
 $V_{IH} = 2V$ (MIN), $V_{IL} = 0.8V$ (MAX)
- 50Ω TRANSMISSION LINE DRIVING CAPABILITY
- SYMMETRICAL OUTPUT IMPEDANCE:
 $|I_{OH}| = I_{OL} = 24 \text{ mA}$ (MIN)
- BALANCED PROPAGATION DELAYS:
 $t_{PLH} \cong t_{PHL}$
- OPERATING VOLTAGE RANGE:
 V_{CC} (OPR) = 4.5V to 5.5V
- PIN AND FUNCTION COMPATIBLE WITH 74 SERIES 158
- IMPROVED LATCH-UP IMMUNITY

DESCRIPTION

The ACT158 is an high-speed CMOS QUAD 2-CHANNEL MULTIPLEXER fabricated with sub-micron silicon gate and double-layer metal wiring C²MOS technology. It is ideal for low power applications maintaining high speed operation similar to equivalent Bipolar Schottky TTL.

It consists of four 2-input digital multiplexers with

PRELIMINARY DATA

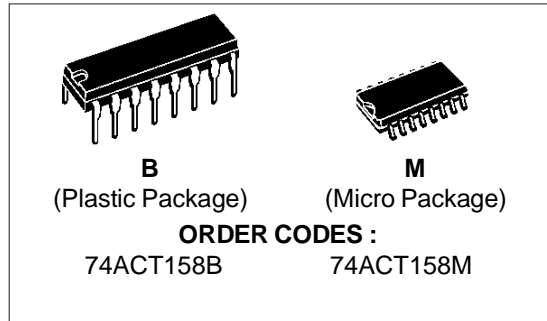

common select and strobe inputs. It is an inverting multiplexer. When the STROBE input is held High selection of data is inhibit and all the outputs become high. The SELECT decoding determines whether the A or B inputs get routed to their corresponding Y outputs.

The device is designed to interface directly High Speed CMOS systems with TTL, NMOS and CMOS output voltage levels.

All inputs and outputs are equipped with protection circuits against static discharge, giving them 2KV ESD immunity and transient excess voltage.

PIN CONNECTION AND IEC LOGIC SYMBOLS

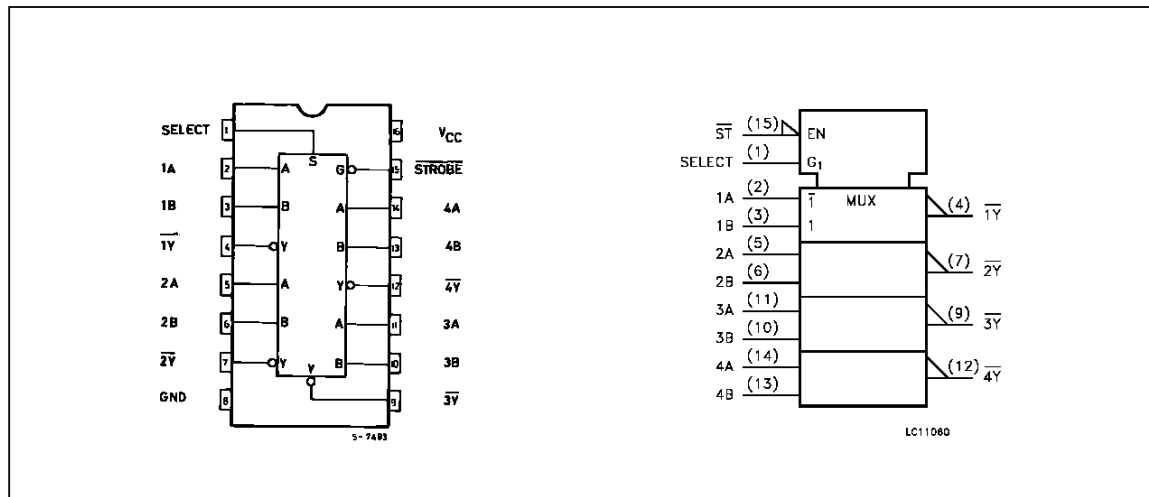

INPUT AND OUTPUT EQUIVALENT CIRCUIT

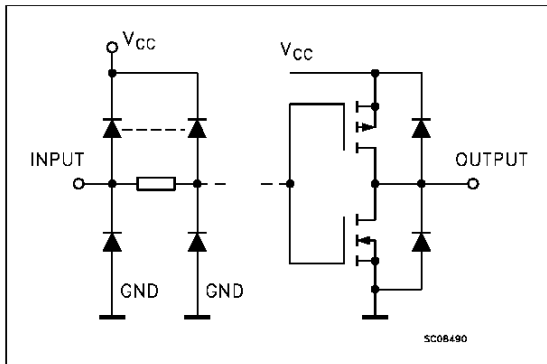

PIN DESCRIPTION

PIN No	SYMBOL	NAME AND FUNCTION
1	SELECT	Common Data Select Input
2, 5, 11, 14	1A to 4A	Data Inputs From Source A
3, 6, 10, 13	1B to 4B	Data Inputs From Source B
4, 7, 9, 12	$\overline{1Y}$ to $\overline{4Y}$	Multiplexer Outputs
15	$\overline{\text{STROBE}}$	Strobe Input
8	GND	Ground (0V)
16	V _{CC}	Positive Supply Voltage

TRUTH TABLE

INPUT				OUTPUT
$\overline{\text{STROBE}}$	SELECT	A	B	\overline{Y}
H	X	X	X	H
L	L	L	X	H
L	L	H	X	L
L	H	X	L	H
L	H	X	H	L

X: "H" or "L"

ABSOLUTE MAXIMUM RATING

Symbol	Parameter	Value	Unit
V _{CC}	Supply Voltage	-0.5 to +7	V
V _I	DC Input Voltage	-0.5 to V _{CC} + 0.5	V
V _O	DC Output Voltage	-0.5 to V _{CC} + 0.5	V
I _{IK}	DC Input Diode Current	± 20	mA
I _{OK}	DC Output Diode Current	± 20	mA
I _O	DC Output Current	± 50	mA
I _{CC} or I _{GND}	DC V _{CC} or Ground Current	± 200	mA
T _{stg}	Storage Temperature	-65 to +150	°C
T _L	Lead Temperature (10 sec)	300	°C

Absolute Maximum Ratings are those values beyond which damage to the device may occur. Functional operation under these condition is not implied.

RECOMMENDED OPERATING CONDITIONS

Symbol	Parameter	Value	Unit
V _{CC}	Supply Voltage	4.5 to 5.5	V
V _I	Input Voltage	0 to V _{CC}	V
V _O	Output Voltage	0 to V _{CC}	V
T _{op}	Operating Temperature:	-40 to +85	°C
dt/dv	Input Rise and Fall Time V _{CC} = 4.5 to 5.5V (note 1)	8	ns/V

1) V_{IN} from 0.8V to 2.0V

DC SPECIFICATIONS

Symbol	Parameter	Test Conditions		Value					Unit
				T _A = 25 °C			-40 to 85 °C		
				V _{CC} (V)	Min.	Typ.	Max.	Min.	
V _{IH}	High Level Input Voltage	4.5	V _O = 0.1 V or V _{CC} - 0.1 V	2.0	1.5		2.0		V
		5.5		2.0	1.5		2.0		
V _{IL}	Low Level Input Voltage	4.5	V _O = 0.1 V or V _{CC} - 0.1 V		1.5	0.8		0.8	V
		5.5			1.5	0.8		0.8	
V _{OH}	High Level Output Voltage	4.5	V _I ^(*) = V _{IH} or V _{IL}	I _O = -50 μA	4.4	4.49		4.4	V
		5.5		I _O = -50 μA	5.4	5.49		5.4	
		4.5		I _O = -24 mA	3.86			3.76	
		5.5		I _O = -24 mA	4.86			4.76	
V _{OL}	Low Level Output Voltage	4.5	V _I ^(*) = V _{IH} or V _{IL}	I _O = 50 μA		0.001	0.1	0.1	V
		5.5		I _O = 50 mA		0.001	0.1	0.1	
		4.5		I _O = 24 mA			0.36	0.44	
		5.5		I _O = 24 mA			0.36	0.44	
I _I	Input Leakage Current	5.5	V _I = V _{CC} or GND				±0.1	±1	μA
I _{CCT}	Max I _{CC} /Input	5.5	V _I = V _{CC} - 2.1 V		0.6			1.5	mA
I _{CC}	Quiescent Supply Current	5.5	V _I = V _{CC} or GND			8		80	μA
I _{OLD}	Dynamic Output Current (note 1, 2)	5.5	V _{OLD} = 1.65 V max V _{OHD} = 3.85 V min					75	mA
I _{OHD}								-75	mA

1) Maximum test duration 2ms, one output loaded at time

2) Incident wave switching is guaranteed on transmission lines with impedances as low as 50 Ω.

(*) All outputs loaded.

AC ELECTRICAL CHARACTERISTICS ($C_L = 50 \text{ pF}$, $R_L = 500 \Omega$, Input $t_r = t_f = 3 \text{ ns}$)

Symbol	Parameter	Test Condition		Value					Unit	
				V_{CC} (V)	$T_A = 25 \text{ }^\circ\text{C}$			$-40 \text{ to } 85 \text{ }^\circ\text{C}$		
					Min.	Typ.	Max.	Min.		Max.
t_{PLH} t_{PHL}	Propagation Delay Time SELECT to Y	$5.0^{(*)}$		1.5	5.5	9.0	1.0	10.0	ns	
t_{PLH} t_{PHL}	Propagation Delay Time STROBE to Y	$5.0^{(*)}$		1.5	5.5	9.5	1.0	10.5	ns	
t_{PLH} t_{PHL}	Propagation Delay Time A, B to Y	$5.0^{(*)}$		1.5	4.0	7.5	1.0	8.5	ns	

(*) Voltage range is $5V \pm 0.5V$

CAPACITIVE CHARACTERISTICS

Symbol	Parameter	Test Conditions		Value					Unit	
				V_{CC} (V)	$T_A = 25 \text{ }^\circ\text{C}$			$-40 \text{ to } 85 \text{ }^\circ\text{C}$		
					Min.	Typ.	Max.	Min.		Max.
C_{IN}	Input Capacitance	5.0			4				pF	
C_{PD}	Power Dissipation Capacitance (note 1)	5.0			TBD				pF	

1) C_{PD} is defined as the value of the IC's internal equivalent capacitance which is calculated from the operating current consumption without load. (Refer to Test Circuit). Average operating current can be obtained by the following equation. $I_{CC(opr)} = C_{PD} \cdot V_{CC} \cdot f_{IN} + I_{CC0/n}$ (per circuit)

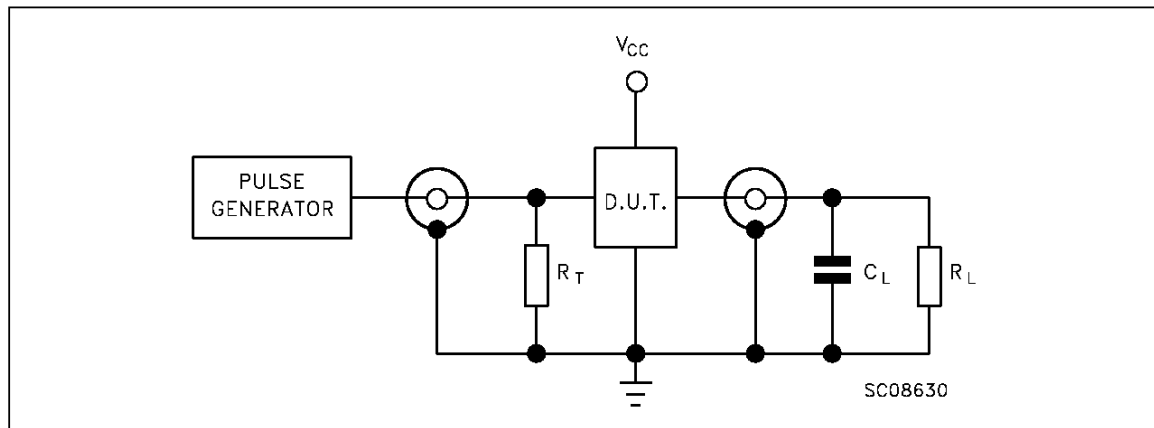
TEST CIRCUIT

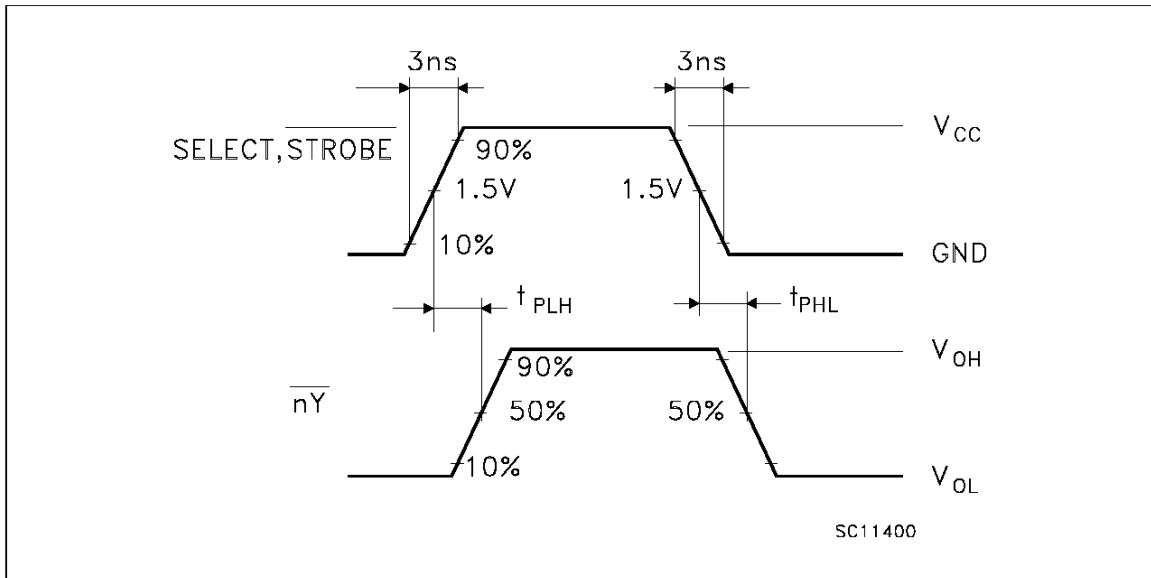
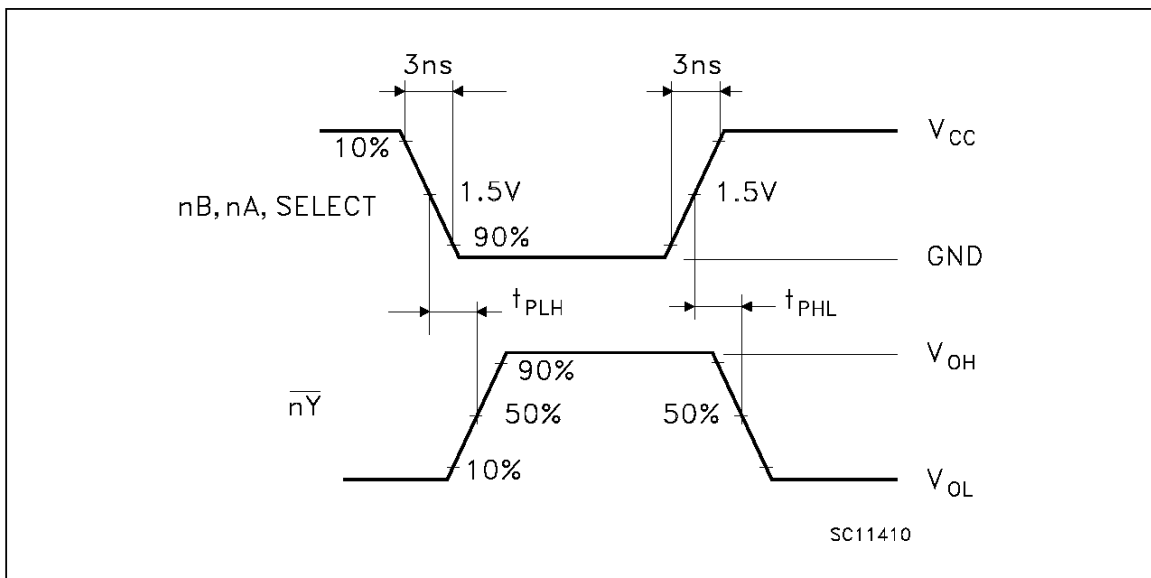
WAVEFORM 1: PROPAGATION DELAYS FOR NON-INVERTING CONDITIONS

WAVEFORM 2: PROPAGATION DELAYS FOR INVERTING CONDITIONS

Plastic DIP-16 (0.25) MECHANICAL DATA
--

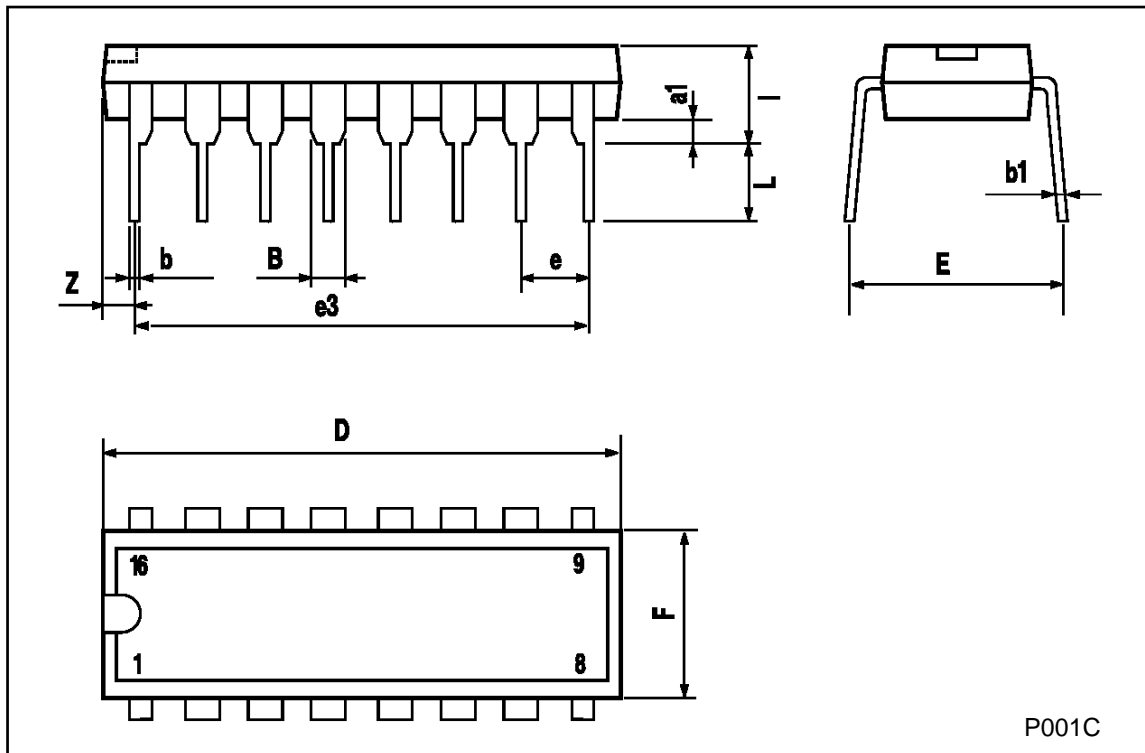
DIM.	mm			inch		
	MIN.	TYP.	MAX.	MIN.	TYP.	MAX.
a1	0.51			0.020		
B	0.77		1.65	0.030		0.065
b		0.5			0.020	
b1		0.25			0.010	
D			20			0.787
E		8.5			0.335	
e		2.54			0.100	
e3		17.78			0.700	
F			7.1			0.280
l			5.1			0.201
L		3.3			0.130	
Z			1.27			0.050



SO-16 MECHANICAL DATA

DIM.	mm			inch		
	MIN.	TYP.	MAX.	MIN.	TYP.	MAX.
A			1.75			0.068
a1	0.1		0.2	0.004		0.007
a2			1.65			0.064
b	0.35		0.46	0.013		0.018
b1	0.19		0.25	0.007		0.010
C		0.5			0.019	
c1	45 (typ.)					
D	9.8		10	0.385		0.393
E	5.8		6.2	0.228		0.244
e		1.27			0.050	
e3		8.89			0.350	
F	3.8		4.0	0.149		0.157
G	4.6		5.3	0.181		0.208
L	0.5		1.27	0.019		0.050
M			0.62			0.024
S	8 (max.)					

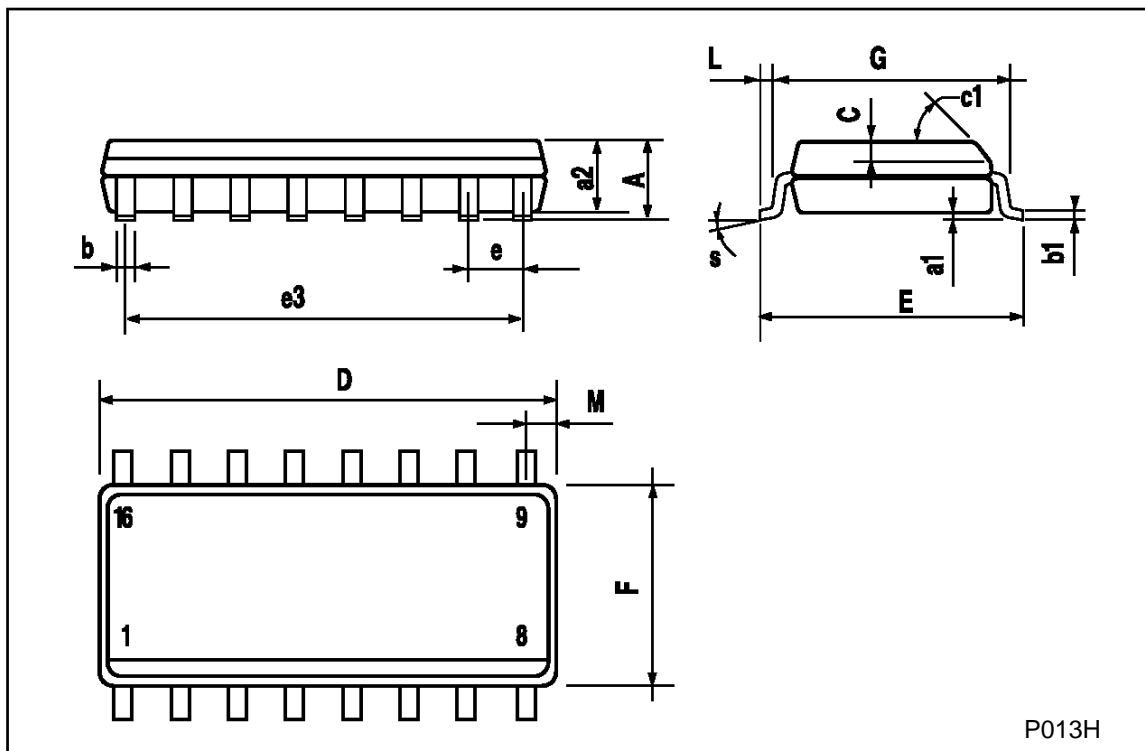

Information furnished is believed to be accurate and reliable. However, SGS-THOMSON Microelectronics assumes no responsibility for the consequences of use of such information nor for any infringement of patents or other rights of third parties which may result from its use. No license is granted by implication or otherwise under any patent or patent rights of SGS-THOMSON Microelectronics. Specifications mentioned in this publication are subject to change without notice. This publication supersedes and replaces all information previously supplied. SGS-THOMSON Microelectronics products are not authorized for use as critical components in life support devices or systems without express written approval of SGS-THOMSON Microelectronics.

© 1997 SGS-THOMSON Microelectronics - Printed in Italy - All Rights Reserved

SGS-THOMSON Microelectronics GROUP OF COMPANIES

Australia - Brazil - Canada - China - France - Germany - Hong Kong - Italy - Japan - Korea - Malaysia - Malta - Morocco - The Netherlands - Singapore - Spain - Sweden - Switzerland - Taiwan - Thailand - United Kingdom - U.S.A