



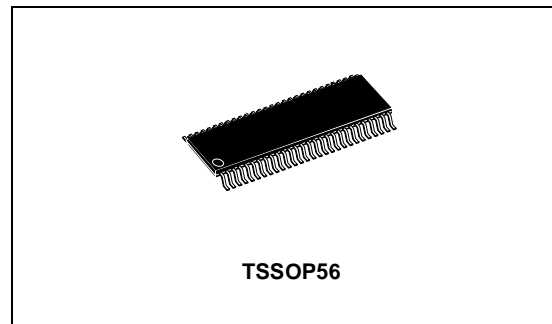
STLVDS385

+3.3V PROGRAMMABLE LVDS TRANSMITTER 24-BIT FLAT PANEL DISPLAY (FPD) LINK-85MHZ

- 20 TO 85 MHz SHIFT CLOCK SUPPORT
- BEST-IN-CLASS SET & HOLD TIMES ON TxINPUTs
- Tx POWER CONSUMPTION <130 mW (typ) @85MHz GRAYSCALE
- Tx POWER-DOWN MODE <200µW (max)
- SUPPORTS VGA, SVGA, XGA AND SINGLE/ DUAL PIXEL SXGA.
- NARROW BUS REDUCES CABLE SIZE AND COST
- UP TO 2.38 Gbps THROUGHPUT
- UP TO 297.5 Megabytes/sec BANDWIDTH
- 345 mV (typ) SWING LVDS DEVICES FOR LOW EMI
- PLL REQUIRES NO EXTERNAL COMPONENTS
- COMPATIBLE WITH TIA/EIA -644 LVDS STANDARD

DESCRIPTION

The STLVDS385 transmitter converts 28 bits of LVCMOS/LVTTL data into four LVDS (Low Voltage Differential Signaling) data streams. A phase-locked transmit clock is transmitted in parallel with the data streams over a fifth LVDS

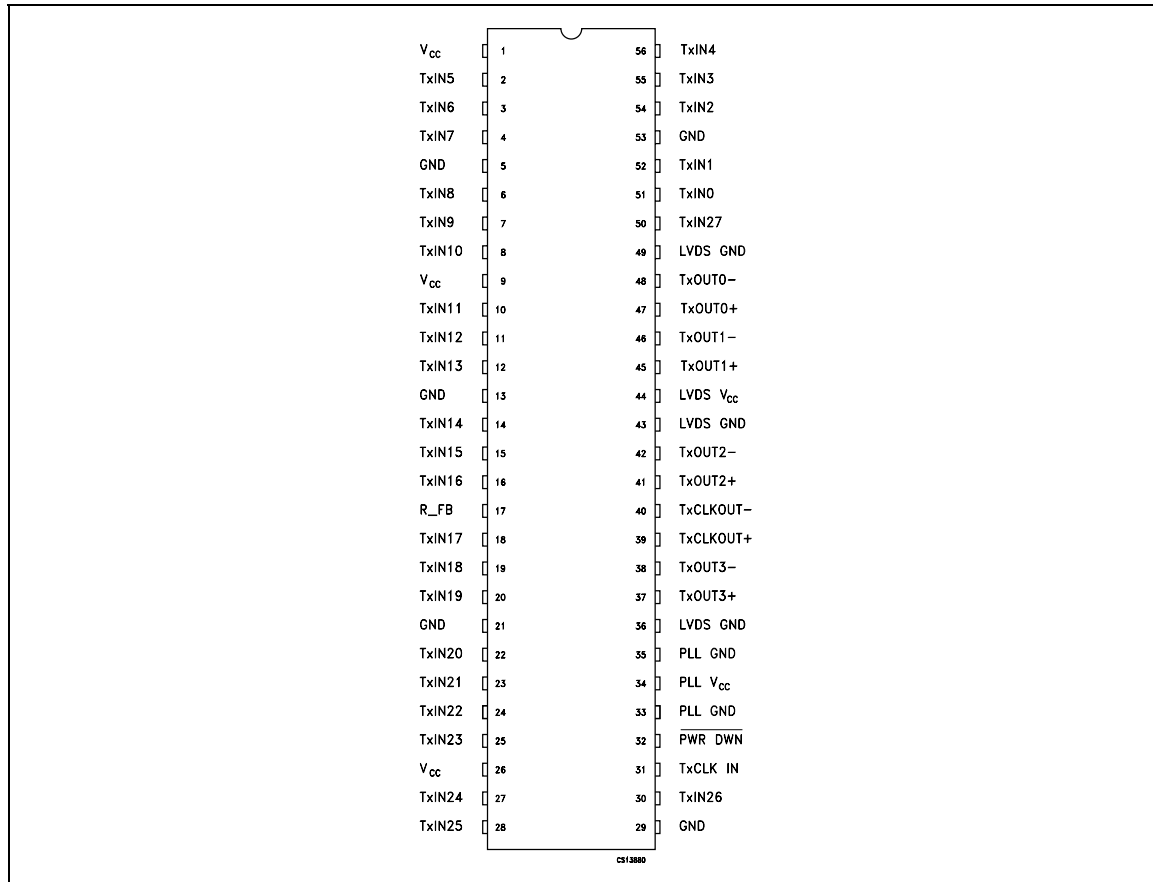


link. Every cycle of the transmit clock 28 bits of input data are sampled and transmitted. At a transmit clock frequency of 85 MHz, 24 bits of RGB data and 3 bits of LCD timing and control data (FPLINE, FPFRAME, DRDY) are transmitted at a rate of 595 Mbps per LVDS data channel. Using a 85 MHz clock, the data throughput is 297.5 Mbytes/sec. The transmitter can be programmed for Rising edge strobe or Falling edge strobe through a dedicated pin. A Rising edge or Falling edge strobe transmitter will inter operate with a Falling edge strobe Receiver without any translation logic.

ORDERING CODES

Type	Temperature Range	Package	Comments
STLVDS385BTR	-10 to 70°C	TSSOP56 (Tape & Reel)	2000 parts per reel

PIN CONFIGURATION



PIN DESCRIPTION

PIN N°	SYMBOL	NAME AND FUNCTION
1, 9, 26	V _{CC}	Power Supply pins for TTL Inputs
2, 3, 4, 6, 7, 8, 10, 11, 12, 14, 15, 16, 18, 19, 20, 22, 23, 24, 25, 27, 28, 30, 50, 51, 52, 54, 55, 56	T _X IN	TTL level input. This includes: 8 Red, 8 Green, 8 Blue and 4 control lines- FPLINE, FPFRAME, and DRDY (also referred to as HSYNC, VSYNC, Data Enable)
5, 13, 21, 29	GND	Ground pins for TTL Inputs
17	R_FB	Programmable strobe select (See Table 1)
31	TxCLKIN	TTL level clock input. Pin name TxCLK IN
32	$\overline{\text{PWRDWN}}$	TTL level input. When asserted (low input) TRI-STATES the outputs, ensuring low current at power down
33, 35	PLL GND	Ground pins for PLL
34	PLL V _{CC}	Power Supply pin for PLL
36, 43, 49	LVDS GND	Ground pins for LVDS outputs
37, 41, 45, 47	TxOUT+	Positive LVDS differential data output
38, 42, 46, 48	TxOUT-	Negative LVDS differential data output
39	TxCLK OUT+	Positive LVDS differential clock output
40	TxCLK OUT-	Negative LVDS differential clock output
44	LVDS V _{CC}	Power Supply pin for LVDS outputs

TABLE 1 PROGRAMMABLE TRANSMITTER

PIN	CONDITION	STROBE STATUS
R_FB	R_FB = V _{CC}	Rising edge strobe
R_FB	R_FB = GND or NC	Falling edge strobe

ABSOLUTE MAXIMUM RATINGS

Symbol	Parameter	Value	Unit
V _{CC}	Supply Voltage	-0.3 to 4	V
V _I	CMOS/TTL Input Voltage	-0.5 to (V _{CC} + 0.3)	V
V _{DO}	LVDS Driver Output Voltage	-0.3 to (V _{CC} + 0.3)	V
I _{OSD}	LVDS Output Short Circuit Duration	Continuous	
ESD	HBM	7	KV
	EIAJ	500	V
I _{LATCH}	Latch Up Tolerance	± 300	mA
T _J	Junction Temperature	+150	°C
T _{stg}	Storage Temperature Range	-65 to +150	°C

Absolute Maximum Ratings are those values beyond which damage to the device may occur. Functional operation under these condition is not implied.

RECOMMENDED OPERATING CONDITIONS

Symbol	Parameter	Min.	Typ.	Max.	Unit
V _{CC}	Supply Voltage	3.0	3.3	3.6	V
T _A	Operating Free Air Temperature	0		70	°C
ΔV _{CC}	Supply Noise Voltage			100	mV _{PP}
f _{TxCLKIN}	TxCLKIN frequency	20		85	MHZ

RECOMMENDED TRANSMITTER INPUT CHARACTERISTICS (V_{CC} = 3.3V, T_J = -10 to 70°C unless otherwise noted. Typical values are referred to T_A = 25°C)

Symbol	Parameter	Min.	Typ.	Max.	Unit
t _{CIT}	TxCLK IN Transition Time (Fig. 5)	1.0		6.0	ns
t _{CIP}	TxCLK IN Period (Fig. 6)	11.76	T	50	ns
t _{CIH}	TxCLK IN High Time (Fig. 6)	0.35T	0.5T	0.65T	ns
t _{CIL}	TxCLK IN Low Time (Fig. 6)	0.35T	0.5T	0.65T	ns
t _{XIT}	TxIN Transition Time	1.5		6.0	ns

ELECTRICAL CHARACTERISTICS

LVC MOS/LVTTL DC SPECIFICATIONS (V_{CC} = 3.3V, T_J = -10 to 70°C unless otherwise noted. Typical values are referred to T_A = 25°C)

Symbol	Parameter	Test Conditions	Min.	Typ.	Max.	Unit
V _{IH}	High Level Input Voltage		2.0		V _{CC}	mV
V _{IL}	Low Level Input Voltage		GND		0.8	mV
V _{CL}	Input Clamp Voltage	I _{CL} = -18mA		-0.79	-1.5	V
I _I	Input Current	V _I = 0.4 V, 2.5 or V _{CC}			10	μA
		V _I = GND	-10	0		μA



STLVDS385

LVDS DC SPECIFICATIONS ($V_{CC} = 3.3V$, $T_J = -10$ to $70^\circ C$ unless otherwise noted. Typical values are referred to $T_A = 25^\circ C$)

Symbol	Parameter	Test Conditions	Min.	Typ.	Max.	Unit
V_{OD}	Differential Output Voltage	$R_L = 100\Omega$	250	345	450	mV
ΔV_{OD}	Change in V_{OD} between Complimentary Output States	$R_L = 100\Omega$			35	mV
V_{OS}	Offset Voltage (Note 2)	$R_L = 100\Omega$	1.125	1.25	1.375	V
ΔV_{OS}	Change in V_{OS} between Complimentary Output States	$R_L = 100\Omega$			35	mV
I_{OS}	Output Short Circuit Current	$V_O = 0$, $R_L = 100\Omega$		-3.5	-5	mA
I_{OZ}	Output Tri-State Current	POWERDOWN = 0, $V_O = 0$ or V_{CC}		± 1	± 10	μA

TRANSMITTER SUPPLY CURRENT ($V_{CC} = 3.3V$, $T_J = -10$ to $70^\circ C$ unless otherwise noted. Typical values are referred to $T_A = 25^\circ C$)

Symbol	Parameter	Test Conditions	Min.	Typ.	Max.	Unit	
ICCTW	Transmitter Supply Current Worst Case	$R_L = 100\Omega$, $C_L = 5pF$, Worst Case Pattern (Fig. 1, 3)	f = 32.5 MHz		31	45	mA
			f = 40 MHz		32	50	
			f = 65 MHz		37	55	
			f = 85 MHz		42	60	
ICCTG	Transmitter Supply Current 16 Grayscale	$R_L = 100\Omega$, $C_L = 5pF$, 16 Grayscale Pattern (Fig. 1, 3)	f = 32.5 MHz		29	38	mA
			f = 40 MHz		30	40	
			f = 65 MHz		35	45	
			f = 85 MHz		39	50	
ICCTZ	Transmitter Supply Current Power Down	Powerdown = Low Driver Outputs in Tri-State under Power Down Mode		10	55	μA	

TRANSMITTER SWITCHING CHARACTERISTICS ($V_{CC} = 3.3V$, $T_J = -10$ to $70^\circ C$ unless otherwise noted. Typical values are referred to $T_A = 25^\circ C$)

Symbol	Parameter	Test Conditions	Min.	Typ.	Max.	Unit
t_{LLHT}	LVDS Low-to-High Transition Time (Fig. 4)			0.75	1.5	ns
t_{LLLT}	LVDS High-to-Low Transition Time (Fig. 4)			0.75	1.5	ns
t_{TPP0}	Transmitter Output Pulse Position for BIT 0 (Fig.11 - Note 3)	f = 40 MHz	-0.25	0	0.25	ns
t_{TPP1}	Transmitter Output Pulse Position for BIT 1		3.32	3.57	3.82	ns
t_{TPP2}	Transmitter Output Pulse Position for BIT 2		6.89	7.14	7.39	ns
t_{TPP3}	Transmitter Output Pulse Position for BIT 3		10.46	10.71	10.96	ns
t_{TPP4}	Transmitter Output Pulse Position for BIT 4		14.04	14.29	14.54	ns
t_{TPP5}	Transmitter Output Pulse Position for BIT 5		17.61	17.86	18.11	ns
t_{TPP6}	Transmitter Output Pulse Position for BIT 6		21.18	21.43	21.68	ns
t_{TPP0}	Transmitter Output Pulse Position for BIT 0 (Fig.11 - Note 3)	f = 65 MHz	-0.20	0	0.20	ns
t_{TPP1}	Transmitter Output Pulse Position for BIT 1		2.00	2.20	2.40	ns
t_{TPP2}	Transmitter Output Pulse Position for BIT 2		4.20	4.40	4.60	ns
t_{TPP3}	Transmitter Output Pulse Position for BIT 3		6.39	6.59	6.79	ns
t_{TPP4}	Transmitter Output Pulse Position for BIT 4		8.59	8.79	8.99	ns
t_{TPP5}	Transmitter Output Pulse Position for BIT 5		10.79	10.99	11.19	ns
t_{TPP6}	Transmitter Output Pulse Position for BIT 6		12.99	13.19	13.99	ns
t_{TPP0}	Transmitter Output Pulse Position for BIT 0 (Fig.11 - Note 3)	f = 85 MHz	-0.20	0	0.20	ns
t_{TPP1}	Transmitter Output Pulse Position for BIT 1		1.48	1.68	1.88	ns
t_{TPP2}	Transmitter Output Pulse Position for BIT 2		3.16	3.36	3.56	ns
t_{TPP3}	Transmitter Output Pulse Position for BIT 3		4.84	5.04	5.24	ns
t_{TPP4}	Transmitter Output Pulse Position for BIT 4		6.52	6.72	6.92	ns
t_{TPP5}	Transmitter Output Pulse Position for BIT 5		8.20	8.40	8.60	ns
t_{TPP6}	Transmitter Output Pulse Position for BIT 6		9.88	10.08	10.28	ns
t_{STC}	TxIN Setup to TxCLK IN (Fig. 6)		2.5			ns
t_{HTC}	TxIN Hold to TxCLK IN (Fig. 6)		0			ns
t_{CCD}	TxCLK IN to TxCLK OUT Delay (Fig. 7)	$T_A = 25^\circ C$, $V_{CC} = 3.3V$	3.8		6.3	ns
t_{CCD}	TxCLK IN to TxCLK OUT Delay (Fig. 7)		2.8		7.1	ns
t_{JCC}	Transmitter Jitter Cycle-to-Cycle (Fig. 12 - Note 4)	f = 85 MHz		110	150	ps
		f = 65 MHz		210	230	
		f = 40 MHz		350	370	
t_{PLLS}	Transmitter Phase Lock Loop Set (Fig. 8)			10	ms	
t_{PDD}	Transmitter Power Down Delay (Fig. 10)			100	ns	

Note 1: Current into device pins is defined as positive. Current out of device pins is defined as negative. Voltages are referenced to ground unless otherwise specified (except V_{OD} and ΔV_{OD}).

Note 2: V_{OS} previously referred as V_{CM} .

Note 3: The Minimum and Maximum Limits are based on statistical analysis of the device performance over process, voltage, and temperature range. This parameter is functionality tested only on Automatic Test Equipment (ATE).

Note 4: The limits are based on bench characterization of the device's jitter response over the power supply voltage range. Output clock jitter is measured with a cycle-to-cycle jitter of $\pm 3ns$ applied to the input clock signal while data inputs are switching (See Figures 15 and 16). A jitter event of 3ns, represents worse case jump in the clock edge from most graphics controller VGA chips currently available.

Note 5: The worst case test pattern produces a maximum toggling of digital circuits, LVDS I/O and CMOS/TTL I/O.

Note 6: The 16 grayscale test pattern tests device power consumption for a "typical" LCD display pattern. The test pattern approximates signal switching needed to produce groups of 16 vertical stripes across the display.

Note 7: Figures 1, 2 show a falling edge data strobe (TxCLK IN/RxCLK OUT).

Note 8: Recommended pin to signal mapping. Customer may choose to define differently.



AC TIMING DIAGRAMS

Figure 1 : "Worst Case" Test Pattern (Note 5)

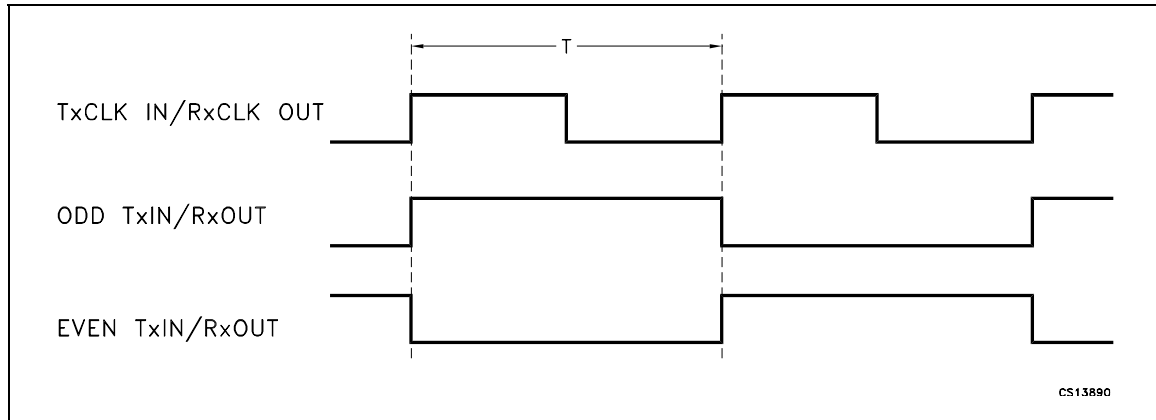


Figure 2 : "16 Grayscale" Test Patter (Notes 6, 7, 8)

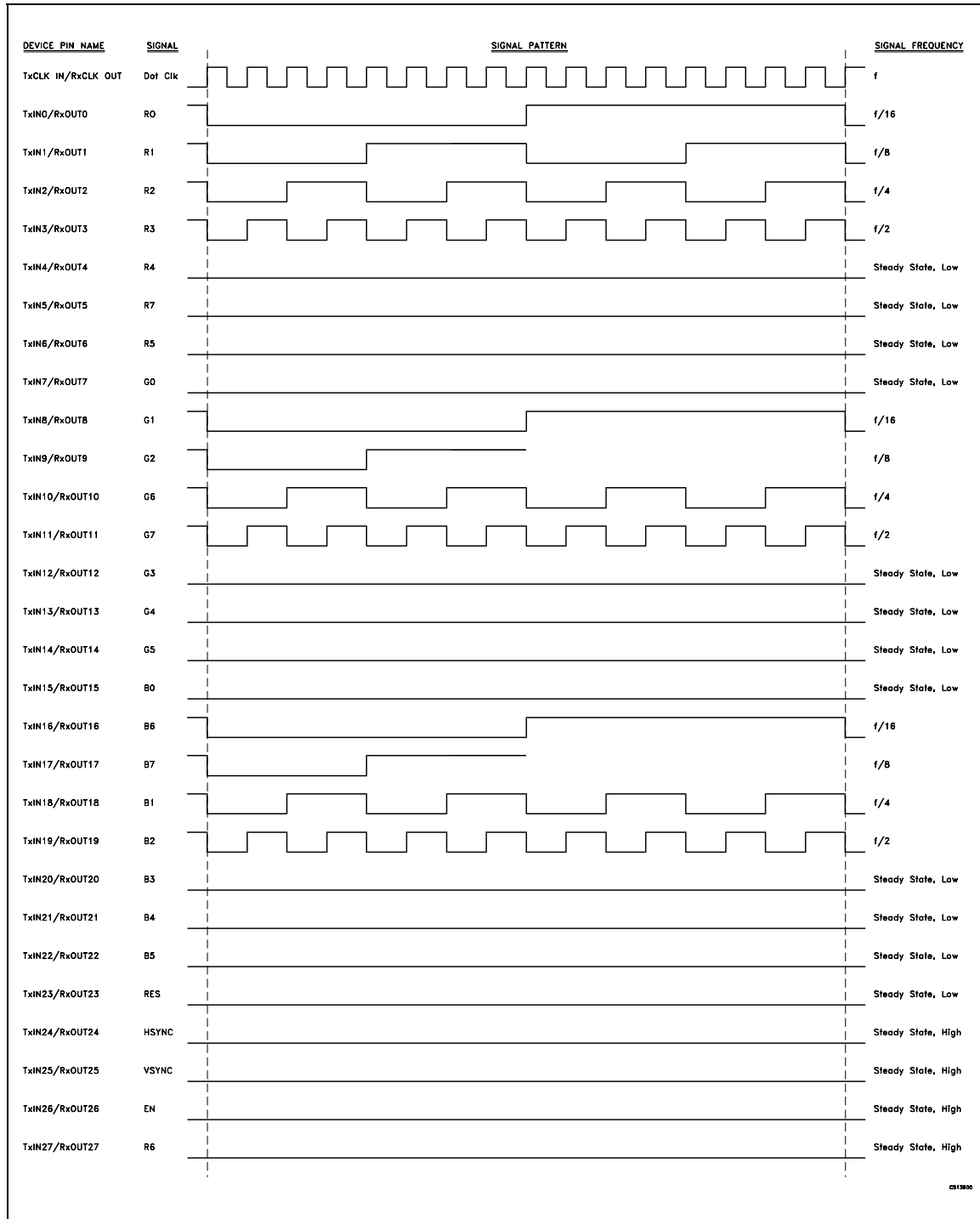


Figure 3 : (Transmitter) LVDS Output Load

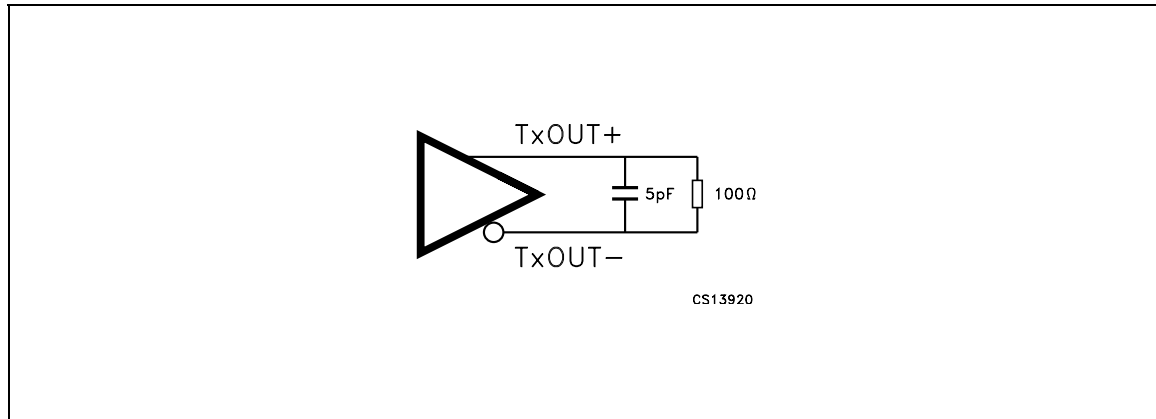


Figure 4 : (Transmitter) LVDS Transition Time

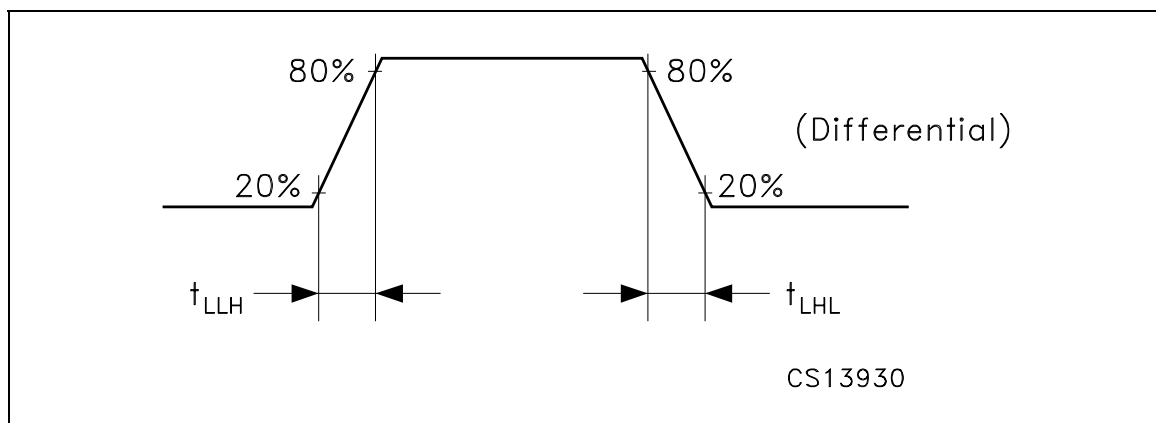


Figure 5 : (Transmitter) Input Clock Transition Time

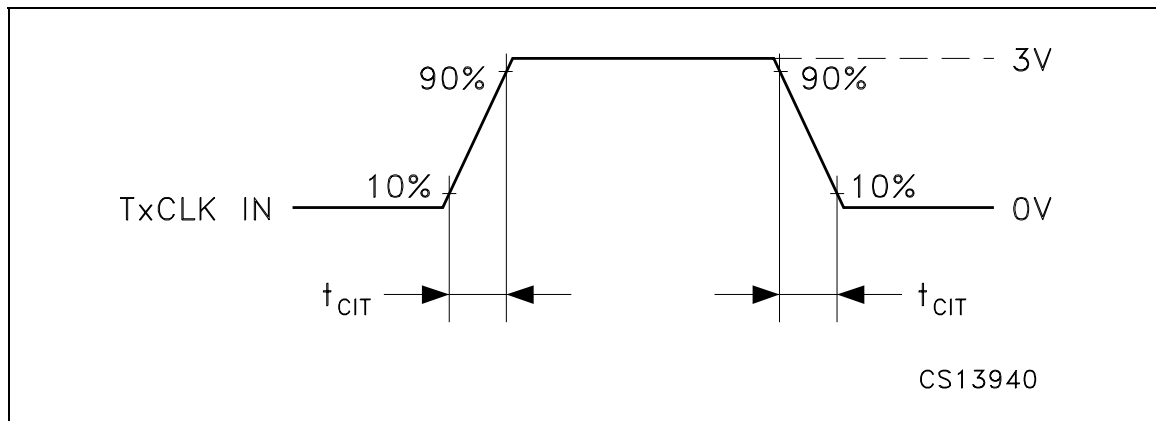


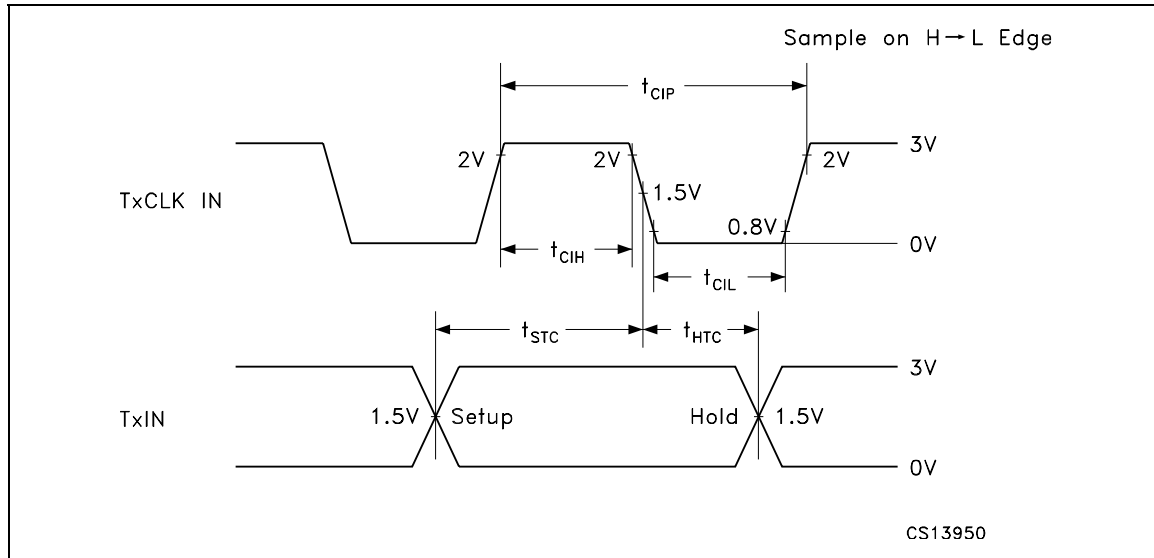
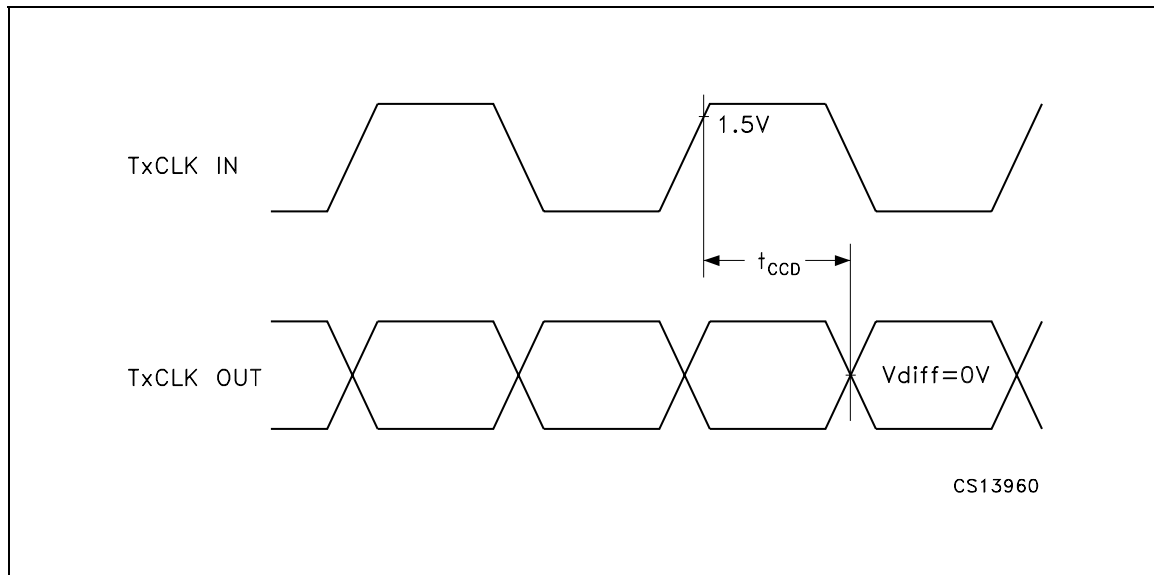
Figure 6 : (Transmitter) Setup/Hold and High/Low Times (Falling Edge Strobe)**Figure 7 :** (Transmitter) Clock In to Clock Out Delay

Figure 8 : (Transmitter) Phase Lock Loop Set Time

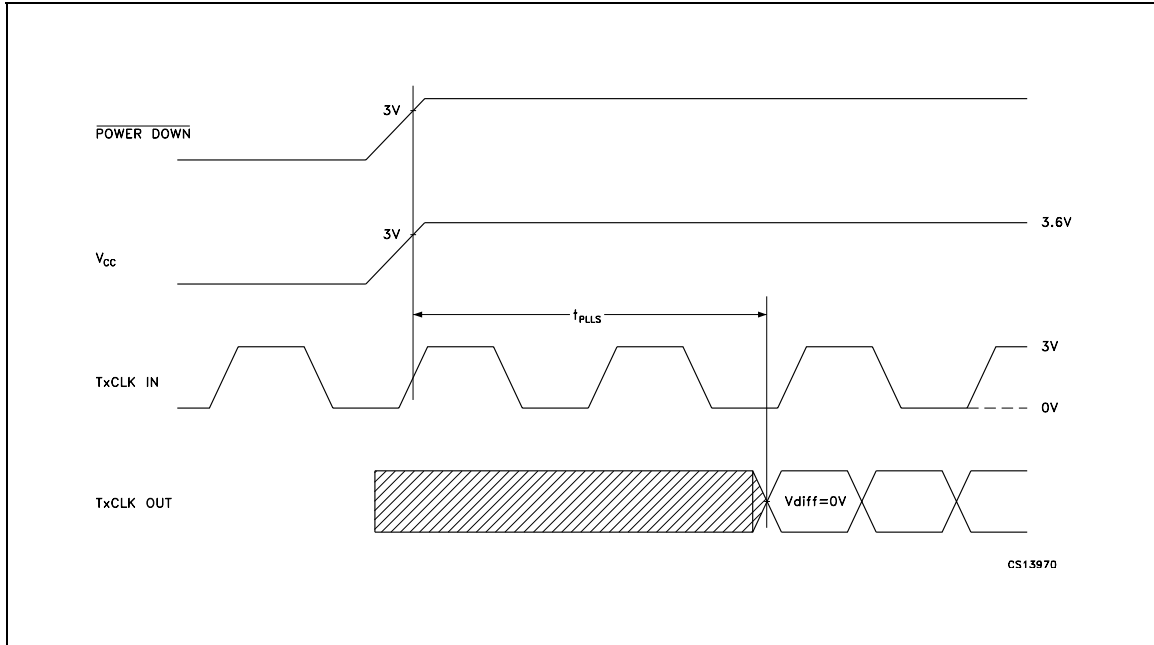


Figure 9 : 28 Parallel TTL Data Inputs Mapped to LVDS Outputs

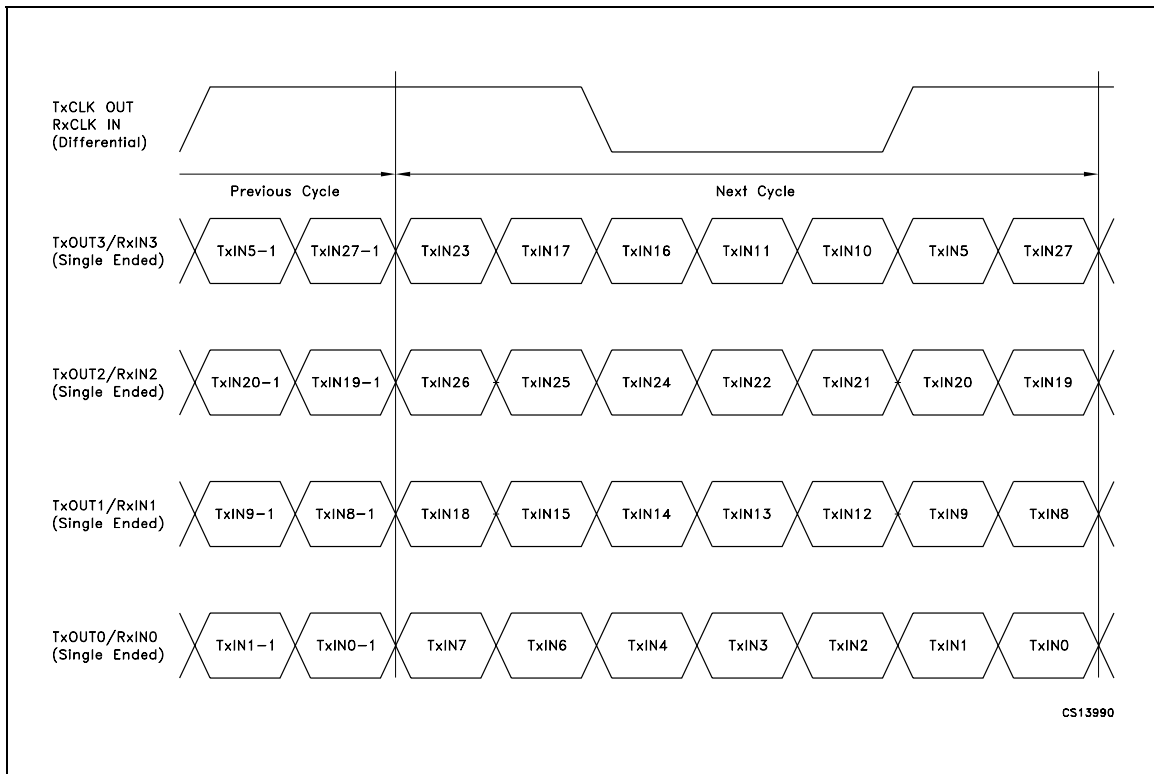


Figure 10 : Transmitter Power Down Delay

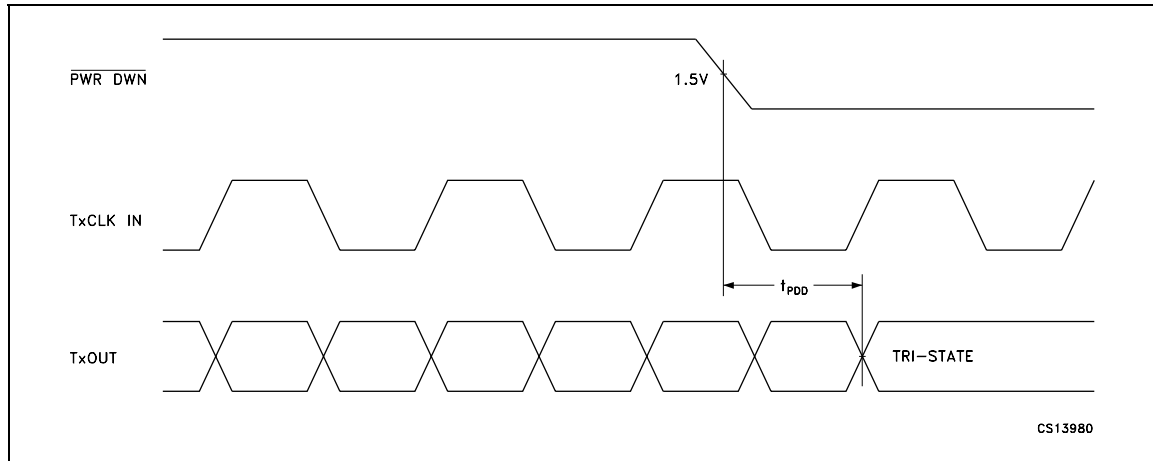
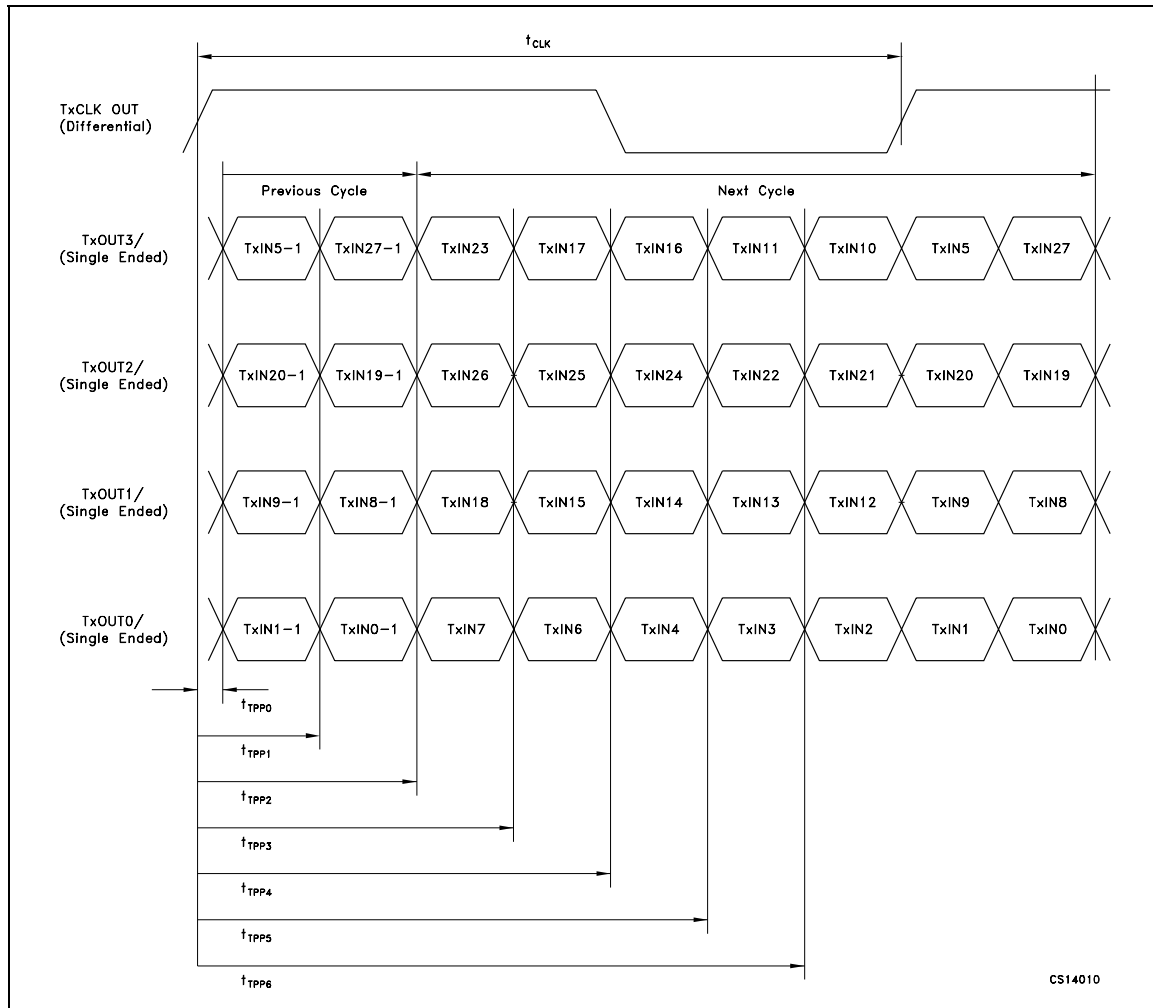
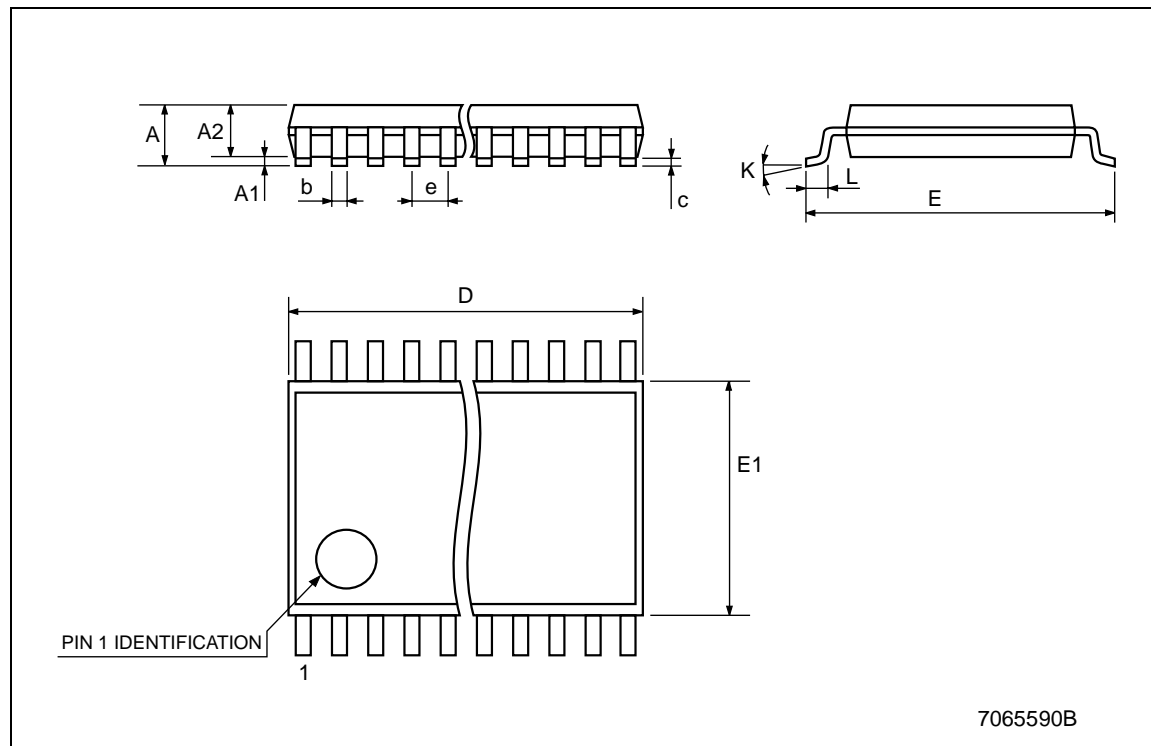


Figure 11 : Transmitter LVDS Output Pulse Position Measurement



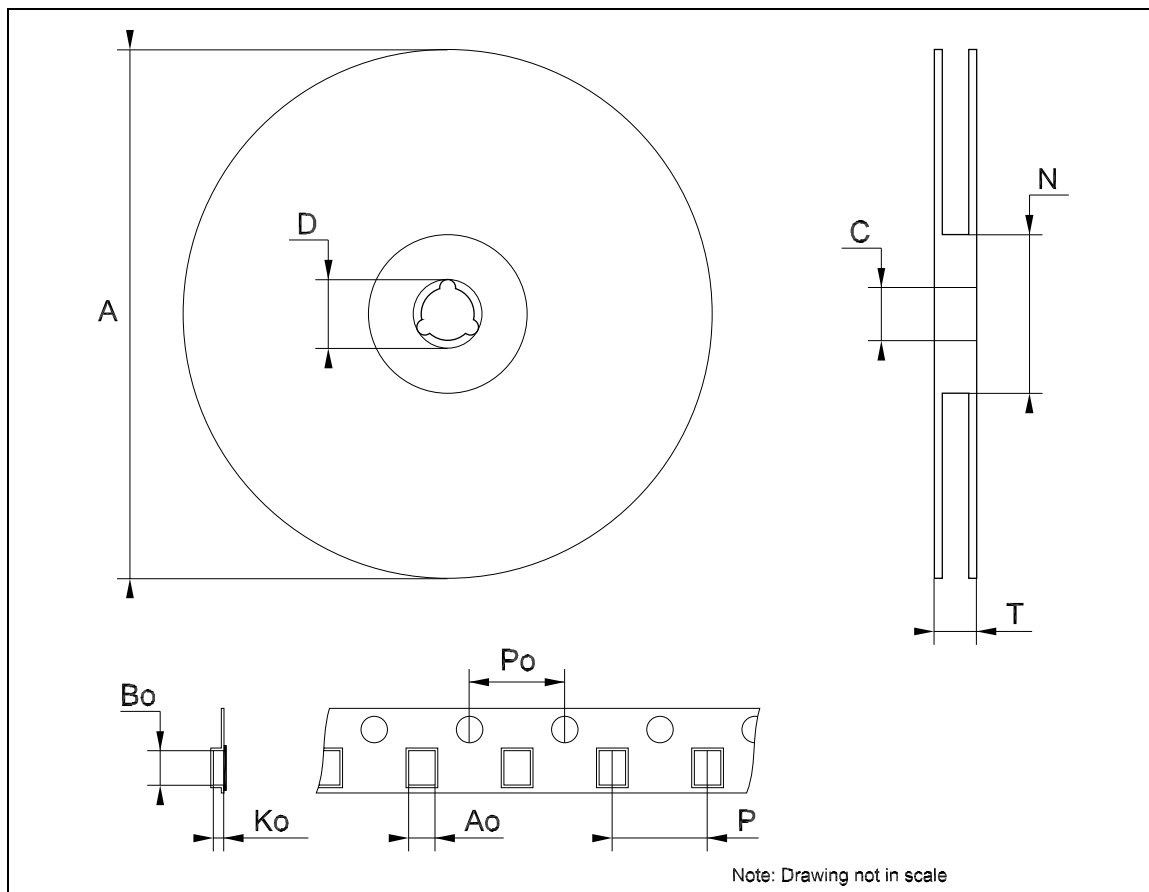
TSSOP56 MECHANICAL DATA

DIM.	mm.			inch		
	MIN.	TYP	MAX.	MIN.	TYP.	MAX.
A			1.2			0.047
A1	0.05		0.15	0.002		0.006
A2		0.9			0.035	
b	0.17		0.27	0.0067		0.011
c	0.09		0.20	0.0035		0.0079
D	13.9		14.1	0.547		0.555
E	7.95		8.25	0.313		0.325
E1	6.0		6.2	0.236		0.244
e		0.5 BSC			0.0197 BSC	
K	0°		8°	0°		8°
L	0.45		0.75	0.020		0.030



Tape & Reel TSSOP56 MECHANICAL DATA

DIM.	mm.			inch		
	MIN.	TYP	MAX.	MIN.	TYP.	MAX.
A			330			12.992
C	12.8		13.2	0.504		0.519
D	20.2			0.795		
N	60			2.362		
T			30.4			1.197
Ao	8.7		8.9	0.342		0.350
Bo	17.2		17.4	0.677		0.685
Ko	1.4		1.6	0.055		0.063
Po	3.9		4.1	0.153		0.161
P	11.9		12.1	0.468		0.476



Information furnished is believed to be accurate and reliable. However, STMicroelectronics assumes no responsibility for the consequences of use of such information nor for any infringement of patents or other rights of third parties which may result from its use. No license is granted by implication or otherwise under any patent or patent rights of STMicroelectronics. Specifications mentioned in this publication are subject to change without notice. This publication supersedes and replaces all information previously supplied. STMicroelectronics products are not authorized for use as critical components in life support devices or systems without express written approval of STMicroelectronics.

The ST logo is a registered trademark of STMicroelectronics
All other names are the property of their respective owners

© 2004 STMicroelectronics - All Rights Reserved
STMicroelectronics GROUP OF COMPANIES

Australia - Belgium - Brazil - Canada - China - Czech Republic - Finland - France - Germany - Hong Kong - India - Israel - Italy - Japan -
Malaysia - Malta - Morocco - Singapore - Spain - Sweden - Switzerland - United Kingdom - United States.
<http://www.st.com>