

# MC33441

## Electroluminescent Lamp Driver IC

The MC33441 is a DC-AC inverter integrated circuit for driving EL lamps. It can boost the supply voltage to the level required by EL lamps and also provide high voltage AC lamp excitation. It consists of an oscillator, a frequency divider, a coil driving circuit and a switched H-bridge network. The input supply voltage range is from 1.8 V to 3.5 V and is capable to supply a typical 140 Vpp AC output voltage. The standby current of the device is typically 10 nA which is ideal for low power portable products. Externally, one inductor and one resistor are needed to generate the desirable voltage charge and to fine tune the oscillator's frequency. This device is offered in 8-Pin TSSOP miniature package. The operating temperature is -20°C to 70°C.

### Features

- Battery Operation 1.8 V – 3.5 V
- Typical Voltage Output 140 Vpp
- Typical Standby Current 10 nA
- Internal Oscillator with External Tuning Resistor
- Enable Control Pin with a 300 K Internal Pull-Down Resistor
- 8-Pin TSSOP Package (Thickness = 1.05 mm, Width = 4.5 mm, Length = 3.1 mm & Lead Pitch = 0.65 mm)

### Types of Applications

- Pagers, Cellular Phones, Portable CD Players/Minidisks
- Databanks, Calculators

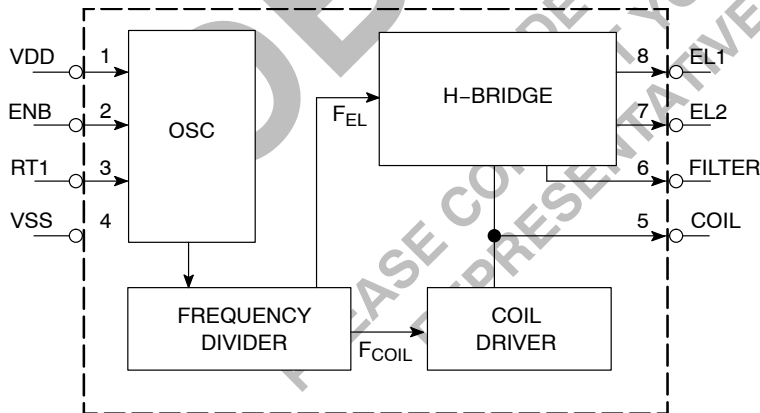

Simplified Block Diagram



ON Semiconductor™

<http://onsemi.com>

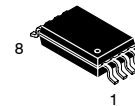

TSSOP-8  
DTB SUFFIX  
CASE 948J

### PIN CONNECTIONS AND MARKING DIAGRAM

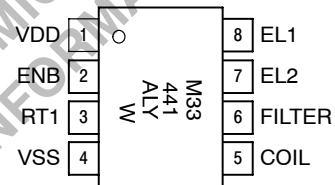

(Top View)

A = Assembly Location  
L = Wafer Lot  
Y = Year  
W = Work Week

### ORDERING INFORMATION

Device	Package	Shipping
MC33441DTBR2	TSSOP-8	2500 Units / Reel

# MC33441

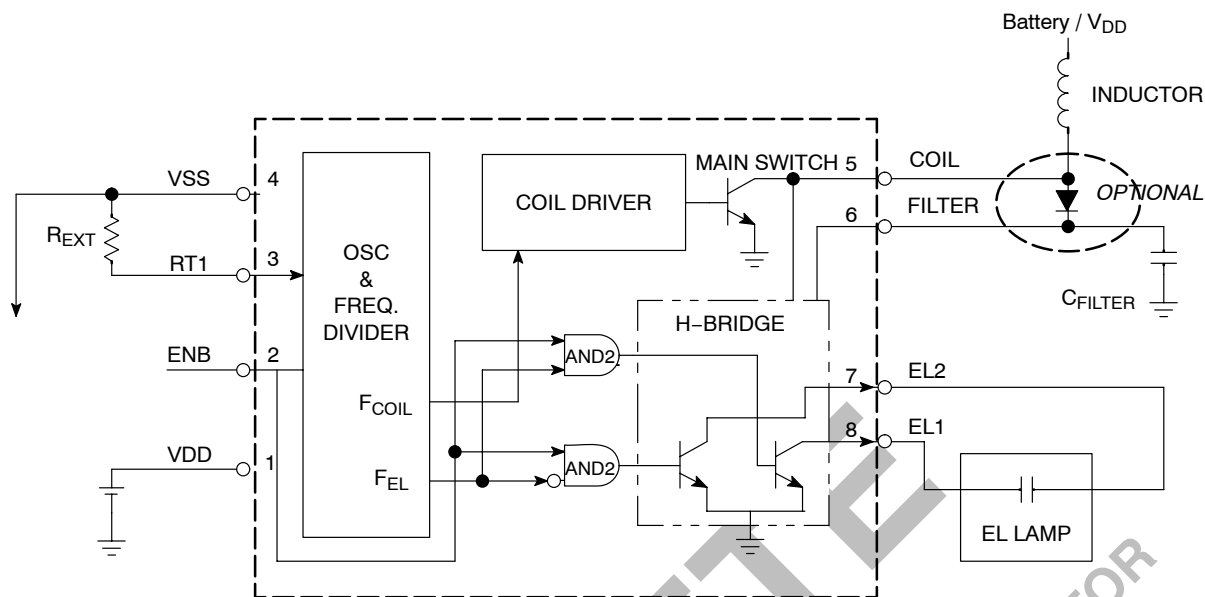

Figure 1. Test Circuit

## PIN FUNCTION DESCRIPTION

Pin No. (TSSOP-8)	Name	Description
Pin 1	VDD	Input voltage supply
Pin 2	ENB	Enable the whole device to operate
Pin 3	RT1	Internal oscillator's fine tuning resistance input
Pin 4	VSS	Analog/Power ground
Pin 5	COIL	Coil/Inductance input
Pin 6	Filter	EL Filter
Pin 7	EL2	EL lamp driver output 2
Pin 8	EL1	EL lamp driver output 1

# MC33441

## MAXIMUM RATINGS ( $T_C = 25^\circ\text{C}$ , unless otherwise noted.)

Rating	Symbol	Max	Unit
Power Supply Voltage	$V_{DD}$	7.5	V
Digital Input Voltage Range	LOGIC = 0 LOGIC = 1	0.5 $V_{DD}$	V
Operating Junction Temperature	$T_{J(max)}$	150	$^\circ\text{C}$
Operating Ambient Temperature	$T_A$	-20 to +70	$^\circ\text{C}$
Storage Temperature Range	$T_{stg}$	-50 to +150	$^\circ\text{C}$
Power Dissipation	$P_D$	300	mW
Thermal Resistance, Junction-to-Air	$R_{\theta JA}$	178	$^\circ\text{C/W}$

## DC ELECTRICAL CHARACTERISTICS ( $V_{DD} = 2.65\text{ V}$ , $T_A = 25^\circ\text{C}$ , Lamp Capacitance = 2.2 nF, Coil = 1 mH unless otherwise noted.)

Characteristic	Symbol	Min	Typ	Max	Unit
Supply Voltage	$V_{DD}$	1.8	-	3.5	V
Output Voltage ( $1.8\text{ V} < V_{DD} \leq 3.5\text{ V}$ )	$V_{EL}$	120	140	160	V
Peak Coil Current ( $1.8\text{ V} < V_{DD} \leq 3.5\text{ V}$ )	$I_{COIL}$	-	70	150	mA
Average Coil Current from Battery ( $1.8\text{ V} < V_{DD} \leq 3.5\text{ V}$ )	$I_{VDD}$	-	35	75	mA dc avg
Standby Current ( $V_{DD} = 3.0\text{ V}$ , ENB = 0)	$I_{STAND}$	-	10	100	nA
Clock Frequency ( $R_{EXT} = 125\text{ K}\Omega$ )	$F_{osc}$	112	140	168	kHz
Lamp Drive Frequency ( $F_{osc}$ Divide by 384)	$F_{EL}$	-	364.6	-	Hz
Coil Drive Frequency ( $F_{osc}$ Divide by 4)	$F_{COIL}$	-	35	-	kHz
Coil Drive Clock Duty Cycle	$DC_{COIL}$	-	75	-	%
EL Lamp Capacitance Range	$C_{EL}$	-	2.2	-	nF

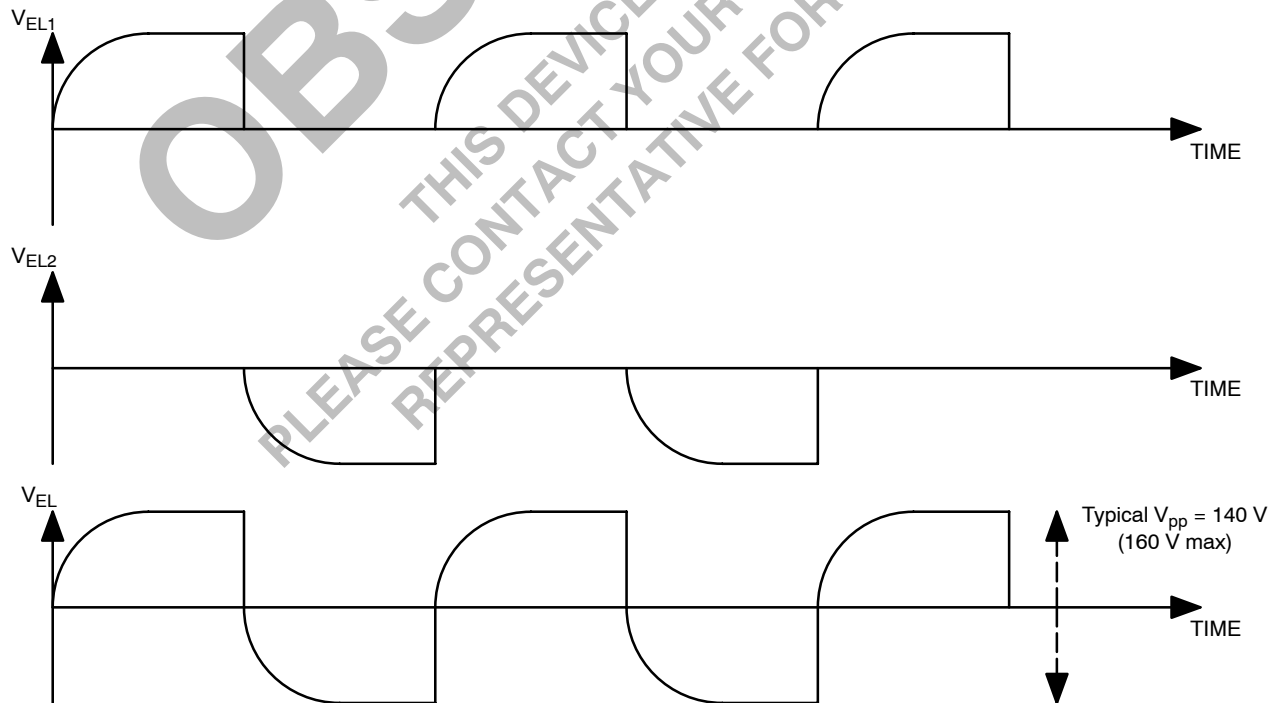

Figure 2. Output Waveform

# MC33441

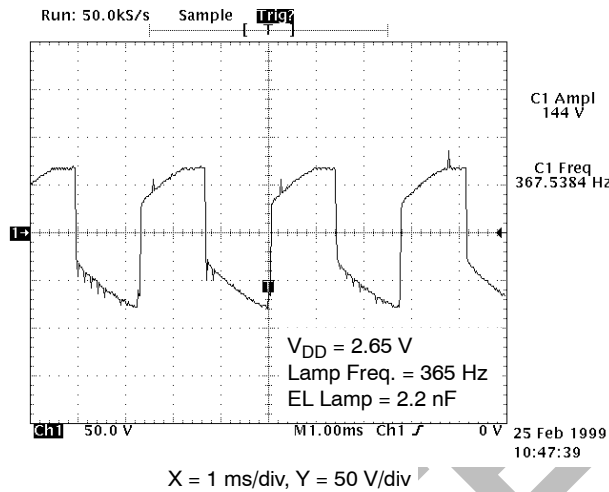

Figure 3. Output Waveform versus Time

## OPERATING DESCRIPTION

### General

The MC33441 is a DC-AC inverter integrated circuit for driving EL lamps. It can boost the supply voltage to the level required by EL lamps and also provide high voltage AC lamp excitation. It consists of an oscillator, a frequency divider, a coil driving circuit and a switched H-bridge network. The input supply voltage range is from 1.8 V to 3.5 V and is capable to supply a typical 140 V<sub>pp</sub> AC output voltage. The standby current of the device is typically 10 nA which is ideal for low power portable products. Externally, one inductor and one resistor are needed to generate the desirable voltage charge and to fine tune the oscillator's frequency. This device is offered in 8-Pin TSSOP packages. The operating temperature is -20°C to 70°C.

### Oscillator and Frequency Divider

Two circuits are put together to form the oscillator. They are Vref and I<sub>bias</sub>. The functionality of Vref block is to generate a zero temperature coefficient (TC) voltage reference which is about 1.27 V. This 1.27 V will then be used in I<sub>bias</sub> circuit to provide current biasing to all of the internal circuits with the value equal to Vref divided by an internal resistor. Besides of that, an external resistor is also connected to this circuit block for setting the oscillator's frequency. The temperature coefficient is dominated by the value of that resistor. Therefore, if a low TC resistor is used, the oscillator frequency's TC can be kept low.

The current mirrors with the induced current equal to the Vref divided by an external resistor are used to charge and discharge an internal capacitor to provide a 50% duty cycle clock signal. This original clock pulse will then be fed into the frequency divider which will generate two additional clock signals with different frequency and duty cycle to the coil-driver and the H-bridge circuits. The oscillator frequency is governed by the following equation:

$$F_{OSC} = \left( \frac{1}{6 \times R_{EXT} \times C_{INT}} \right) \text{ Hz} = \frac{1.667 \times 10^{10}}{R_{EXT}} \text{ Hz}$$

$$F_{COIL} = F_{OSC} \div 4$$

$$F_{EL} = F_{OSC} \div 384$$

where C<sub>INT</sub> is about 10pF.

### Coil Driver

The coil driver is basically a simplified boost converter. It takes a higher frequency clock signal from the frequency divider to turn on/off the main switch alternatively. When the main switch is on, current will flow through the coil to ground. Once the switch is being turned off, the energy stored in the coil will be released to the external capacitor (EL lamp) through an internal diode. According to the frequency of the clock signals between the coil driver and the H-bridge, the external capacitor (EL lamp) will be charging to the desirable level.

Current limit circuit (typical 70 mA & max. 150 mA) is implemented in this device. Since the current through the coil will increase corresponding to the input voltage, if the input voltage is high and the inductance of the coil is small, the coil can be saturated. The current limit feature is used to avoid this happen. The main switch is parallel to a much smaller switch which has their collector and their base connected together. However, the emitter of the smaller switch is tied to a sensing resistor while the emitter of the main switch is connected to ground. The coil current will split into two according to the sizing ratio between the main and the smaller switch. The current through the smaller switch will also flow through the sensing resistor and generates a voltage. If the voltage across this sensing resistor is above the pre-set value, then both switches

will be turned off and the energy will release to the EL lamp. And, those switches will remain off until the next clock cycle.

**H-Bridge Network**

To achieve the 140 V peak-to-peak voltage, H-bridge network is used to charge and discharge the EL lamp. The switching frequency of the bridge network is controlled by a clock signal from the divider with its frequency much lower than the one to the coil-driver. Moreover, to reduce the current consumption, the biasing current to the two low-side switches of the H-bridge is not activated until the coil-driver circuit needed to release the energy to the EL lamp. Then, the biasing circuit will be on and be ready before the main switch in the coil-driver really starts to turn off.

**External Components**

System designer will base on the application to decide the size and the type of the EL lamp to be used. The external resistance (R<sub>EXT</sub>) at RT1 pin determines the excitation frequency (F<sub>EL</sub>) for the lamp. The relationship between R<sub>EXT</sub> and the frequency is:

$$F_{EL} = F_{OSC} \div 384$$

By substitute the equation of F<sub>OSC</sub> from *Oscillator & Frequency Divider*.

$$F_{EL} = \frac{4.341 \times 10^7}{R_{EXT}} \text{ Hz}$$

so

$$R_{EXT} = \frac{4.341 \times 10^7}{F_{EL}} \Omega$$

Moreover, if a low TC resistor is used, the oscillator frequency's TC can be kept low. The filter capacitor is to provide a smooth and more stable output waveform for the EL lamp. The value of this capacitor depends on the input voltage and the coil's inductance value. Equations below can be used to estimate filter capacitor's value at different input voltage.

**Best Case Approximation for the Filter Capacitor:**

$$C_{FILTER} = 0.026 \times (V_{in} - V_{SW})^2 / (L \times F_{OSC}^2)$$

**Worst Case Approximation for the Filter Capacitor:**

$$C_{FILTER} = 0.085 \times (V_{in} - V_{SW})^2 / (L \times F_{OSC}^2)$$

where V<sub>IN</sub> is the input voltage, V<sub>SW</sub> is voltage across the switch when it is on, L is the coil's value and F<sub>OSC</sub> is the clock frequency.

Measurement below is recorded with the condition: coil = 1 mH, EL lamp = 2.2 nF and at room temperature.

**Table 1: Reference for C<sub>FILTER</sub>**

VDD	R <sub>EXT</sub>	C <sub>FILTER</sub>
1.8 V	100 K-130 KΩ	5 n-10 nF
2.0 V	100 K-130 KΩ	10 n-22 nF
2.5 V	100 K-130 KΩ	10 n-22 nF
3.0 V	100 K-130 KΩ	22 nF-33 nF

TYPICAL OPERATING CHARACTERISTICS

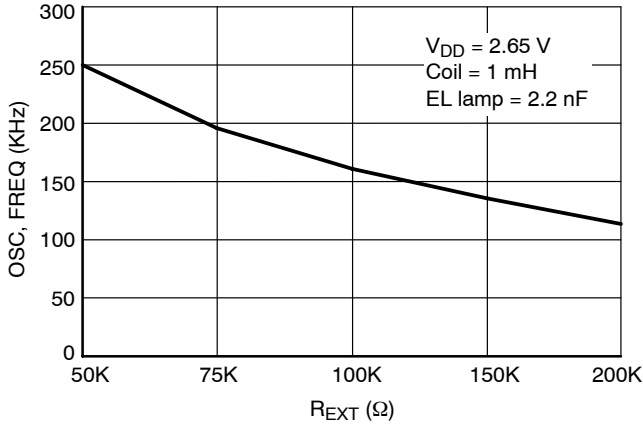

Figure 4. Oscillator Frequency versus R<sub>EXT</sub>

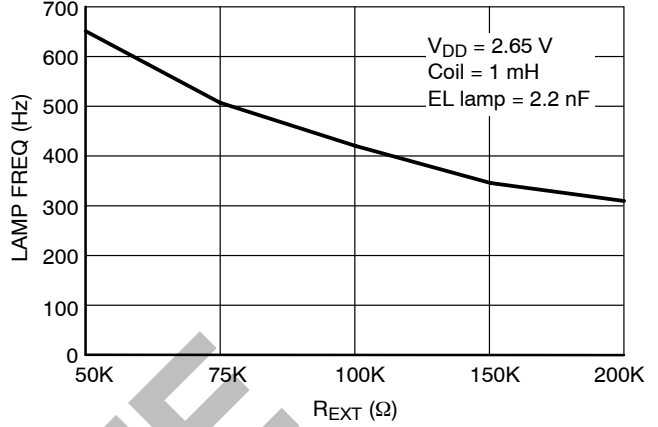

Figure 5. Lamp Frequency versus R<sub>EXT</sub>

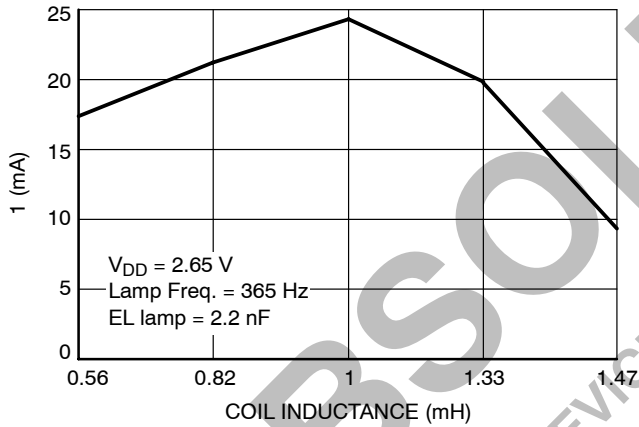

Figure 6. Current Consumption versus Coil Inductance

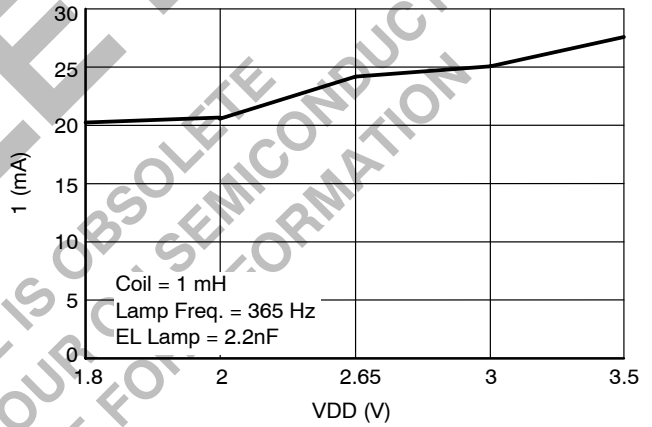

Figure 7. Current Consumption versus V<sub>DD</sub>

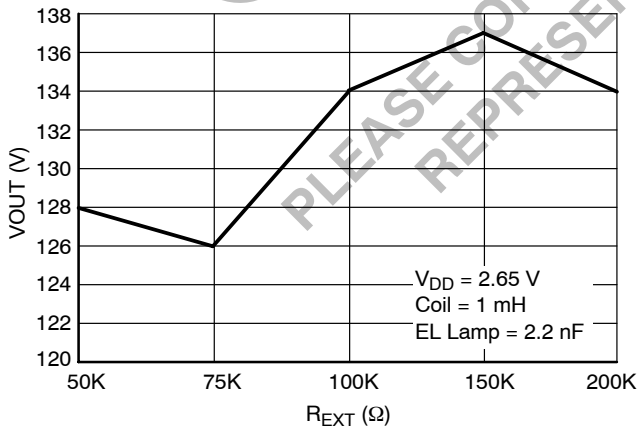

Figure 8. Output Voltage versus R<sub>EXT</sub>

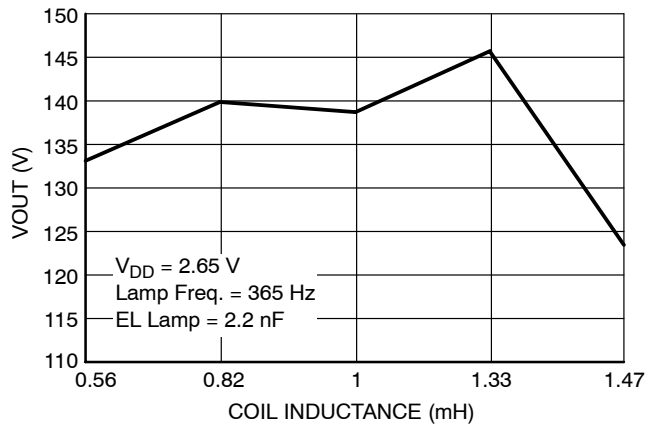

Figure 9. Output Voltage versus Coil Inductance

APPLICATION INFORMATION

**EL Lamp Selection**

EL lamps are a laminate which exhibit a capacitance on the order of 2.5 nF to 3.5 nF per square inch. The light will emit as the high voltage is applied across the electrodes of this capacitance. The color of the emitted light is determined by the type of chemical used and the frequency of the excitation voltage. On the other hand, the lamp brightness increases approximately the square of the applied voltage and nearly linear to the excitation frequency. Once a lamp has been selected, the operating frequency and the essential voltage for the optimum performance is determined. Then, the driver circuit can begin to design.

**Inductor Selection (L1)**

Use a 1 mH/0.15 A inductor for MC33441. Higher inductor values can be used to reduce the peak transient coil current from the battery supply. As the value of the inductor (L1), increases, the resistor (R1) value may need to increase correspondingly to provide optimum performance. While a lower inductor values lead to smaller physical size, it will generate a higher peak coil current. A lower resistor (R1) value should be used when a lower inductance coil is being used.

The inductor must have a saturation current rating equal to or bigger than the peak coil current which is 150 mA.

**Filter Capacitor Selection (C2)**

See Table 1 for the estimated value of the filter capacitors based on the input voltage supply. Since the maximum voltage of the filter capacitor can reach 70 V or even 80 V, capacitor with high voltage rating will be required.

**Resistor Selection (R1)**

Since the fundamental frequency of the oscillator is set by the external resistor (R1), the temperature coefficient of the frequency is dominated by the value of this resistor. A low temperature coefficient (TC) resistor is suggested to use for keeping the variation of oscillator’s frequency low against the operation temperature range. (See Page 4, Fig. 3 & Fig. 4)

$$R1 = R_{EXT} = \frac{4.341 \times 10^7 \Omega}{F_{EL}}$$

**Layout**

The MC33441 is high output voltage operation make PC board layout critical to minimize ground bounce and noise. Locate input bypass capacitor, filter capacitor and oscillator’s resistor as close to the device pins as possible.

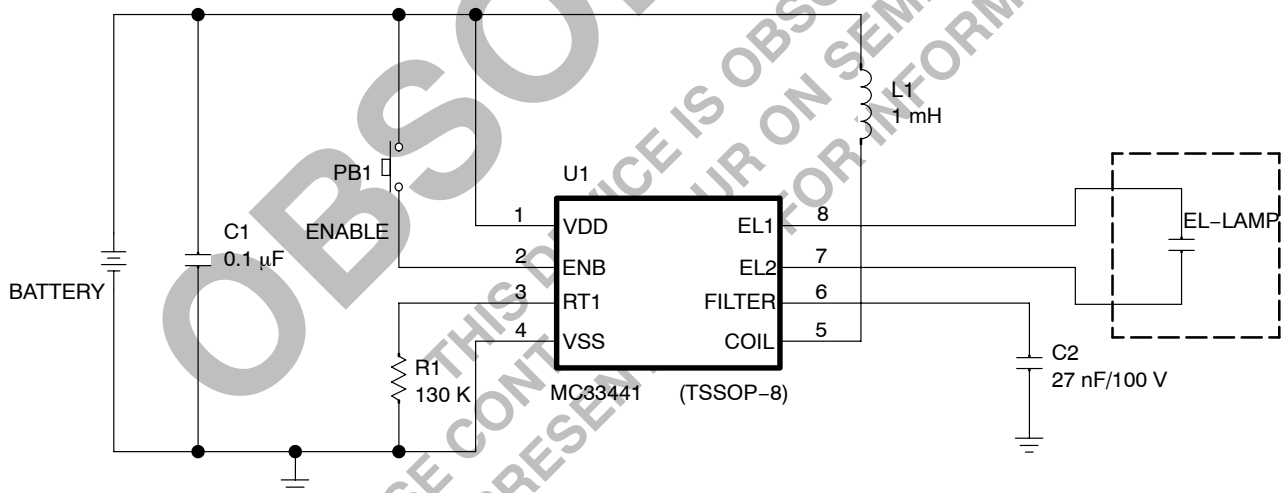

Figure 10. MC33441 Demo Board Schematic

**COMPONENT SUPPLIER**

Supplier	Part Number	Description	Phone
Tech-Wave Industrial Co., Ltd.	Part# CC-0012	EL-Lamp: 14.5 mm x 47 mm Color: Yellow-Green	(886)-2-22692827
Coils Electronics Co., Ltd.	Part# CRCH664-102K-831015	Inductor: 1 mH / 0.15 A	(852)-2341-5539

MC33441

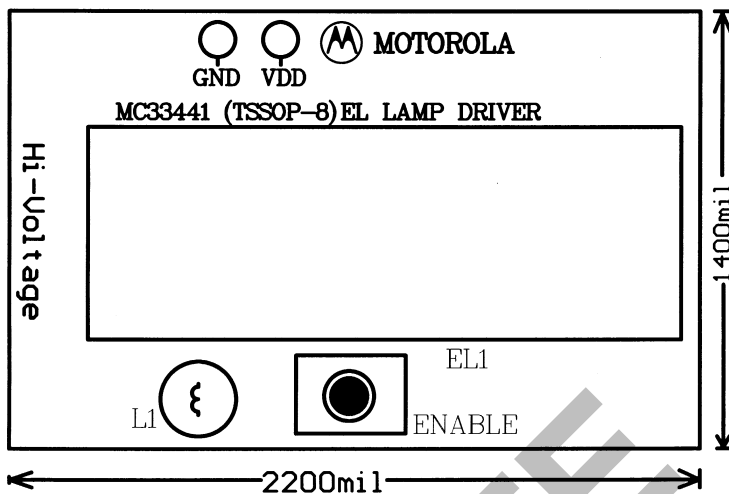

Figure 11. MC33441 PC Board - Top View

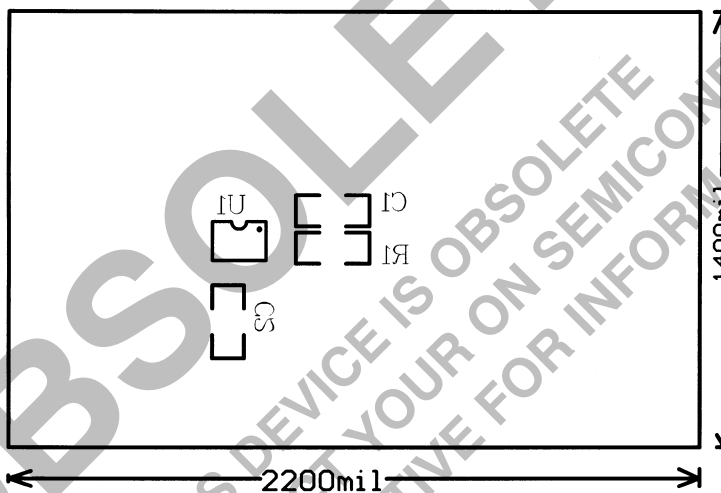

Figure 12. MC33441 Component Placement Guide - Component Side

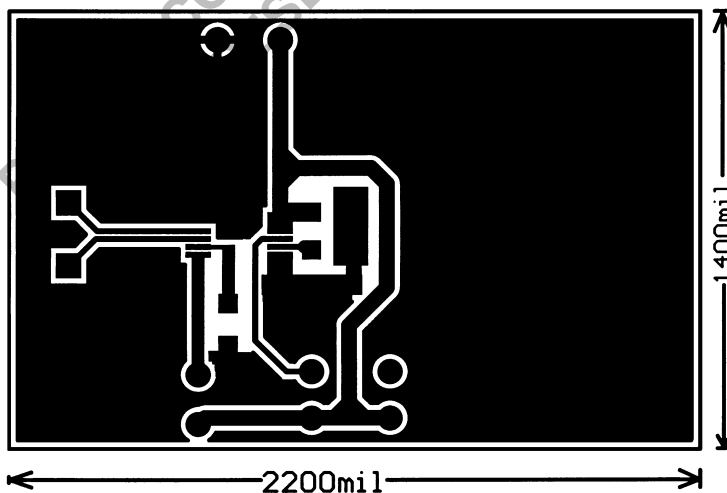

Figure 13. MC33441 PC Board - Bottom View



# MC33441

## PACKAGE DIMENSIONS

TSSOP-8  
DTB SUFFIX  
CASE 948J-01  
ISSUE 0

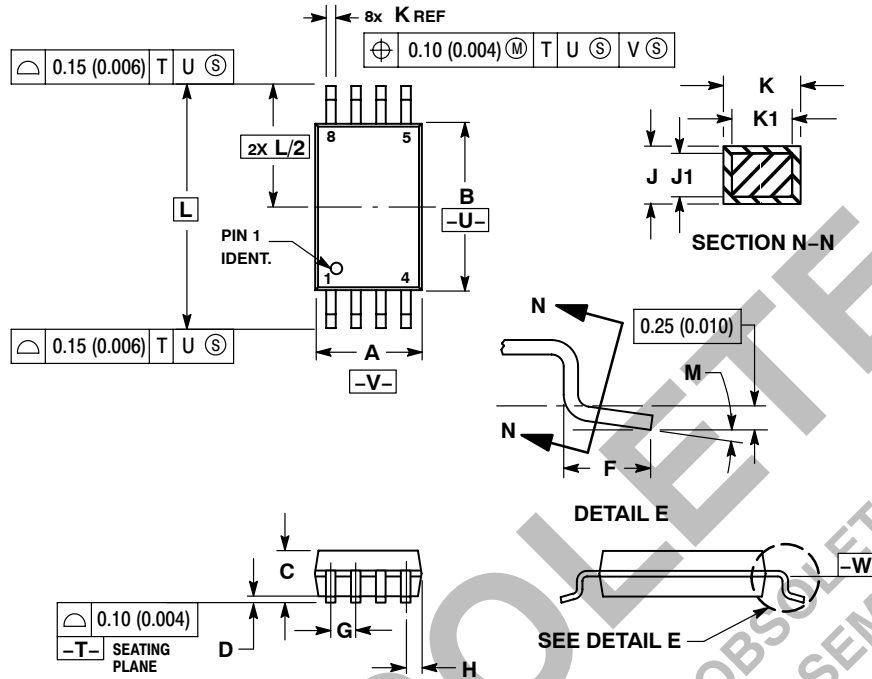

### NOTES:

1. DIMENSIONING AND TOLERANCING PER ANSI Y14.5M, 1982.
2. CONTROLLING DIMENSION: MILLIMETER.
3. DIMENSION A DOES NOT INCLUDE MOLD FLASH. PROTRUSIONS OR GATE BURRS. MOLD FLASH OR GATE BURRS SHALL NOT EXCEED 0.15 (0.006) PER SIDE.
4. DIMENSION B DOES NOT INCLUDE INTERLEAD FLASH OR PROTRUSION. INTERLEAD FLASH OR PROTRUSION SHALL NOT EXCEED 0.25 (0.010) PER SIDE.
5. DIMENSION K DOES NOT INCLUDE DAMBAR PROTRUSION. ALLOWABLE DAMBAR PROTRUSION SHALL BE 0.08 (0.003) TOTAL IN EXCESS OF THE K DIMENSION AT MAXIMUM MATERIAL CONDITION.
6. TERMINAL NUMBERS ARE SHOWN FOR REFERENCE ONLY.
7. DIMENSION A AND B ARE TO BE DETERMINED AT DATUM PLANE -W-.

DIM	MILLIMETERS		INCHES	
	MIN	MAX	MIN	MAX
A	2.90	3.10	0.114	0.122
B	4.30	4.50	0.169	0.177
C	---	1.20	---	0.047
D	0.05	0.15	0.002	0.006
F	0.50	0.75	0.020	0.030
G	0.65 BSC		0.026 BSC	
H	0.50	0.60	0.020	0.024
J	0.09	0.20	0.004	0.008
J1	0.09	0.16	0.004	0.006
K	0.19	0.30	0.007	0.012
K1	0.19	0.25	0.007	0.010
L	6.40 BSC		0.252 BSC	
M	0°	8°	0°	8°

ON Semiconductor and are registered trademarks of Semiconductor Components Industries, LLC (SCILLC). SCILLC reserves the right to make changes without further notice to any products herein. SCILLC makes no warranty, representation or guarantee regarding the suitability of its products for any particular purpose, nor does SCILLC assume any liability arising out of the application or use of any product or circuit, and specifically disclaims any and all liability, including without limitation special, consequential or incidental damages. "Typical" parameters which may be provided in SCILLC data sheets and/or specifications can and do vary in different applications and actual performance may vary over time. All operating parameters, including "Typicals" must be validated for each customer application by customer's technical experts. SCILLC does not convey any license under its patent rights nor the rights of others. SCILLC products are not designed, intended, or authorized for use as components in systems intended for surgical implant into the body, or other applications intended to support or sustain life, or for any other application in which the failure of the SCILLC product could create a situation where personal injury or death may occur. Should Buyer purchase or use SCILLC products for any such unintended or unauthorized application, Buyer shall indemnify and hold SCILLC and its officers, employees, subsidiaries, affiliates, and distributors harmless against all claims, costs, damages, and expenses, and reasonable attorney fees arising out of, directly or indirectly, any claim of personal injury or death associated with such unintended or unauthorized use, even if such claim alleges that SCILLC was negligent regarding the design or manufacture of the part. SCILLC is an Equal Opportunity/Affirmative Action Employer. This literature is subject to all applicable copyright laws and is not for resale in any manner.

### PUBLICATION ORDERING INFORMATION

**LITERATURE FULFILLMENT:**  
Literature Distribution Center for ON Semiconductor  
P.O. Box 5163, Denver, Colorado 80217 USA  
**Phone:** 303-675-2175 or 800-344-3860 Toll Free USA/Canada  
**Fax:** 303-675-2176 or 800-344-3867 Toll Free USA/Canada  
**Email:** orderlit@onsemi.com

**N. American Technical Support:** 800-282-9855 Toll Free  
USA/Canada  
**Europe, Middle East and Africa Technical Support:**  
Phone: 421 33 790 2910  
**Japan Customer Focus Center**  
Phone: 81-3-5773-3850

**ON Semiconductor Website:** [www.onsemi.com](http://www.onsemi.com)  
**Order Literature:** <http://www.onsemi.com/orderlit>

For additional information, please contact your local Sales Representative

MC33441/D