

# DATA SHEET

## **TDA9850** I<sup>2</sup>C-bus controlled BTSC stereo/SAP decoder

Preliminary specification  
File under Integrated Circuits, IC02

1995 Jun 19

**I<sup>2</sup>C-bus controlled BTSC stereo/SAP decoder****TDA9850****FEATURES**

- Quasi alignment-free application due to automatic adjustment of channel separation via I<sup>2</sup>C-bus
- Dbx noise reduction circuit
- Dbx decoded stereo, Second Audio Program (SAP) or mono selectable at the AF outputs
- Additional SAP output without dbx, including de-emphasis
- High integration level with automatically tuned integrated filters
- Input level adjustment I<sup>2</sup>C-bus controlled
- Alignment-free SAP processing
- Stereo pilot PLL circuit with ceramic resonator, automatic adjustment procedure for stereo channel separation, two pilot thresholds selectable via I<sup>2</sup>C-bus
- Automatic pilot cancellation
- Composite input noise detector with I<sup>2</sup>C-bus selectable thresholds for stereo and SAP off
- I<sup>2</sup>C-bus transceiver.

**GENERAL DESCRIPTION**

The TDA9850 is a bipolar-integrated BTSC stereo/SAP decoder (I<sup>2</sup>C-bus controlled) for application in TV sets, VCRs and multimedia.

**QUICK REFERENCE DATA**

SYMBOL	PARAMETER	CONDITIONS	MIN.	TYP.	MAX.	UNIT
V <sub>CC</sub>	supply voltage		8.5	9	9.5	V
I <sub>CC</sub>	supply current		–	58	75	mA
V <sub>comp(rms)</sub>	input signal voltage (RMS value)	100% modulation L + R; f <sub>i</sub> = 300 Hz	–	250	–	mV
V <sub>oR(rms)</sub> ; V <sub>oL(rms)</sub>	output signal voltage (RMS value)	100% modulation L + R; f <sub>i</sub> = 300 Hz	–	500	–	mV
G <sub>LA</sub>	input level adjustment control		–3.5	–	+4.0	dB
α <sub>cs</sub>	stereo channel separation	f <sub>L</sub> = 300 Hz; f <sub>R</sub> = 3 kHz	25	35	–	dB
THD <sub>L,R</sub>	total harmonic distortion L + R	f <sub>i</sub> = 1 kHz	–	0.2	–	%
S/N	signal-to-noise ratio	500 mV (RMS) mono output signal				
		CCIR noise weighting filter (peak value)	–	60	–	dB
		DIN noise weighting filter (RMS value)	–	73	–	dB

**ORDERING INFORMATION**

TYPE NUMBER	PACKAGE		
	NAME	DESCRIPTION	VERSION
TDA9850	SDIP32	plastic shrink dual in-line package; 32 leads (400 mil)	SOT232-1
TDA9850T	SO32	plastic small outline package; 32 leads; body width 7.5 mm	SOT287-1

---

**I<sup>2</sup>C-bus controlled BTSC stereo/SAP decoder****TDA9850**

---

**License information**

A license is required for the use of this product. For further information, please contact:

<b>COMPANY</b>	<b>BRANCH</b>	<b>ADDRESS</b>
THAT Corporation	Licensing Operations	734 Forest St. Marlborough, MA 01752 USA Tel.: (508) 229-2500 Fax: (508) 229-2590
	Tokyo Office	405 Palm House, 1-20-2 Honmachi Shibuya-ku, Tokyo 151 Japan Tel.: (03) 3378-0915 Fax: (03) 3374-5191

# I<sup>2</sup>C-bus controlled BTSC stereo/SAP decoder

## TDA9850

### BLOCK DIAGRAM

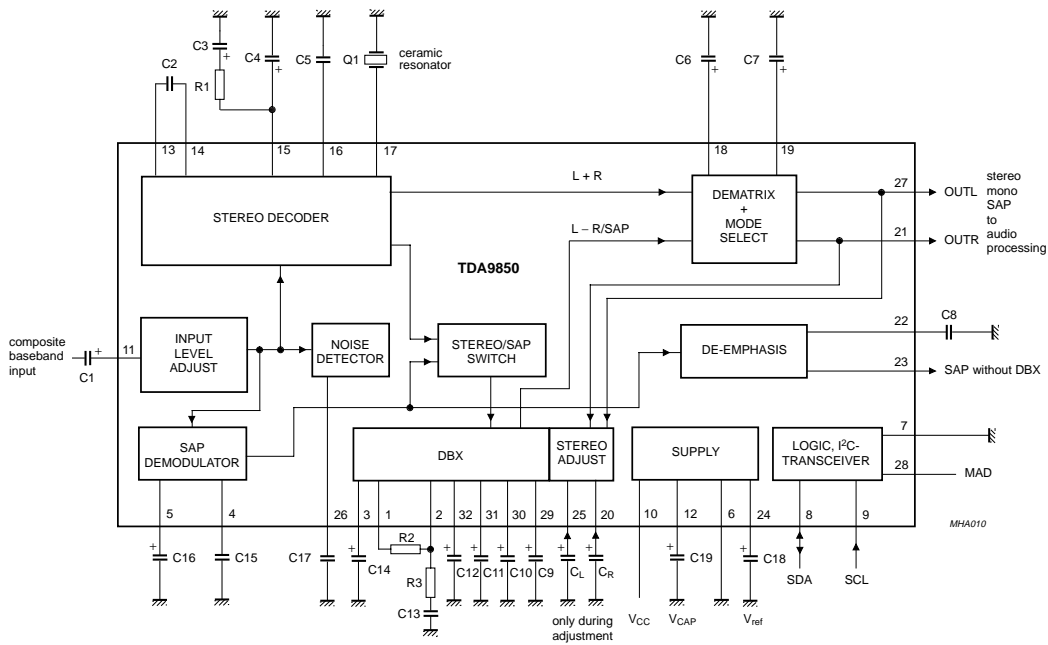

Fig.1 Block, application and test diagram.

I<sup>2</sup>C-bus controlled BTSC stereo/SAP decoder

TDA9850

**COMPONENT LIST**Electrolytic capacitors  $\pm 20\%$ ; foil capacitors  $\pm 10\%$ ; resistors  $\pm 5\%$ ; unless otherwise specified; see Fig.1.

COMPONENT	VALUE	TYPE	REMARK
C1	10 $\mu\text{F}$	electrolytic	63 V
C2	470 nF	foil	
C3	4.7 $\mu\text{F}$	electrolytic	63 V
C4	220 nF	foil	
C5	10 $\mu\text{F}$	electrolytic	63 V; $I_{\text{leak}} < 1.5 \mu\text{A}$
C6	4.7 $\mu\text{F}$	electrolytic	63 V
C7	4.7 $\mu\text{F}$	electrolytic	63 V
C8	15 nF	foil	
C9	10 $\mu\text{F}$	electrolytic	63 V $\pm 10\%$
C10	10 $\mu\text{F}$	electrolytic	63 V $\pm 10\%$
C11	1 $\mu\text{F}$	electrolytic	63 V
C12	1 $\mu\text{F}$	electrolytic	63 V
C13	47 nF	foil	$\pm 5\%$
C14	10 $\mu\text{F}$	electrolytic	63 V
C15	100 nF	foil	
C16	4.7 $\mu\text{F}$	electrolytic	63 V
C17	100 nF	foil	
C18	100 $\mu\text{F}$	electrolytic	16 V
C19	100 $\mu\text{F}$	electrolytic	16 V
CR	2.2 $\mu\text{F}$	electrolytic	63 V
CL	2.2 $\mu\text{F}$	electrolytic	63 V
R1	2.2 k $\Omega$		
R2	8.2 k $\Omega$		$\pm 2\%$
R3	160 $\Omega$		$\pm 2\%$
Q1		CSB503F58	radial leads
		CSB503JF958	alternative as SMD

I<sup>2</sup>C-bus controlled BTSC stereo/SAP decoder

TDA9850

## PINNING

SYMBOL	PIN	DESCRIPTION
VEO	1	variable emphasis output for dbx
VEI	2	variable emphasis input for dbx
C <sub>NR</sub>	3	capacitor noise reduction for dbx
C <sub>M</sub>	4	capacitor mute for SAP
C <sub>DEC</sub>	5	capacitor DC-decoupling for SAP
AGND	6	analog ground
DGND	7	digital ground
SDA	8	serial data input/output
SCL	9	serial clock input
V <sub>CC</sub>	10	supply voltage (+9 V)
COMP	11	composite input signal
V <sub>CAP</sub>	12	capacitor for electronic filtering of supply
C <sub>P1</sub>	13	capacitor for pilot detector
C <sub>P2</sub>	14	capacitor for pilot detector
C <sub>PH</sub>	15	capacitor for phase detector
C <sub>ADJ</sub>	16	capacitor for filter adjustment
CER	17	ceramic resonator
C <sub>MO</sub>	18	capacitor DC-decoupling mono
C <sub>SS</sub>	19	capacitor DC-decoupling stereo/SAP
C <sub>R</sub>	20	adjustment capacitor, right channel
OUTR	21	output, right channel
C <sub>SDE</sub>	22	capacitor SAP de-emphasis
SAP	23	SAP output
V <sub>ref</sub>	24	reference voltage $0.5 \times (V_{CC} - 1.5 V)$
C <sub>L</sub>	25	adjustment capacitor, left channel
C <sub>ND</sub>	26	noise detector capacitor
OUTL	27	output, left channel
MAD	28	programmable address bit
C <sub>TW</sub>	29	capacitor timing wideband for dbx
C <sub>TS</sub>	30	capacitor timing spectral for dbx
C <sub>W</sub>	31	capacitor wideband for dbx
C <sub>S</sub>	32	capacitor spectral for dbx

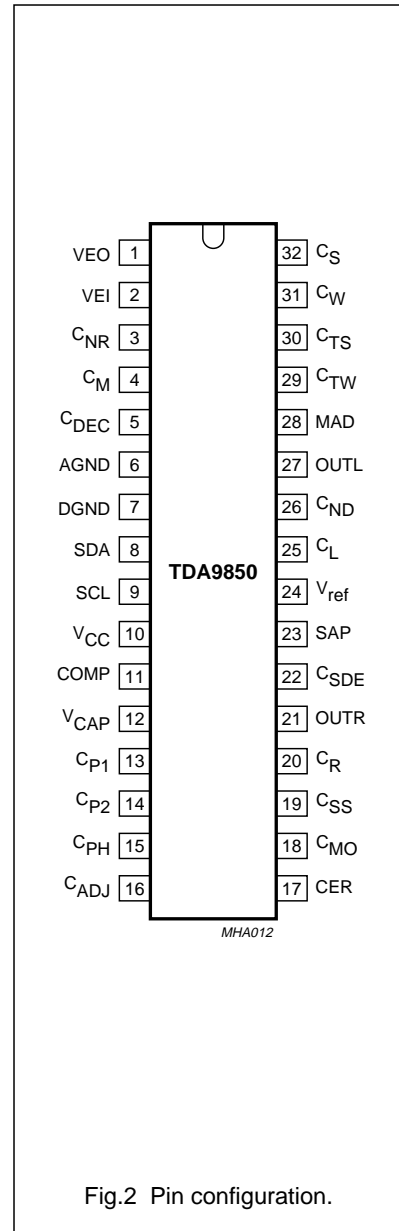

Fig.2 Pin configuration.

## I<sup>2</sup>C-bus controlled BTSC stereo/SAP decoder

TDA9850

### FUNCTIONAL DESCRIPTION

#### Input level adjustment

The composite input signal is fed to the input level adjustment stage. The control range is from -3.5 to +4.0 dB in steps of 0.5 dB. The subaddress control 4 of Tables 5 and 6 and the level adjust setting of Table 10 allows an optimum signal adjustment during the set alignment. The maximum input signal voltage is 2 V (RMS).

#### Stereo decoder

The output signal of the level adjustment stage is coupled to a low-pass filter which suppresses the baseband noise above 125 kHz. The composite signal is then fed into a pilot detector/pilot cancellation circuit and into the MPX demodulator. The main L + R signal passes a 75  $\mu$ s fixed de-emphasis filter and is fed into the dematrix circuit. The decoded sub-signal L - R is sent to the stereo/SAP switch. To generate the pilot signal the stereo demodulator uses a PLL circuit including a ceramic resonator. The stereo channel separation is adjusted by an automatic procedure to be performed during set production. For a detailed description see Section "Adjustment procedure". The stereo identification can be read by the I<sup>2</sup>C-bus (see Table 2). Two different pilot thresholds (data STS = 1; STS = 0) can be selected via the I<sup>2</sup>C-bus (see Table 14).

#### SAP demodulator

The composite signal is fed from the output of the input level adjustment stage to the SAP demodulator circuit through a 5f<sub>H</sub> band-pass filter. The demodulator level is automatically controlled. The SAP demodulator includes an internal field strength detector that mutes the SAP output in the event of insufficient signal conditions. The SAP identification signal can be read by the I<sup>2</sup>C-bus (see Table 2).

#### Noise detector

The composite input noise increases with decreasing antenna signal. This makes it necessary to switch stereo or SAP off at certain thresholds. These thresholds can be set via the I<sup>2</sup>C-bus. With ST0 to ST3 (see Table 6) the stereo threshold can be selected and with SP0 to SP3 the SAP threshold. A hysteresis can be achieved via software by making the threshold dependent of the identification bits STP and SAPP (see Table 2).

#### Mode selection

The stereo/SAP switch feeds either the L - R signal or the SAP demodulator output signal via the internal dbx noise reduction circuit to the dematrix/switching circuit. Table 8 shows the different switch modes provided at the output pins OUTR and OUTL.

#### dbx decoder

The dbx circuit includes all blocks required for the noise reduction system in accordance with the BTSC system specification. The output signal is fed through a 73  $\mu$ s fixed de-emphasis circuit to the dematrix block.

#### SAP output

Independent of the stereo/SAP switch, the SAP signal is also available at pin SAP. At SAP, the SAP signal is not dbx decoded. The capacitor at SDE provides a recommended de-emphasis (150  $\mu$ s) at SAP.

#### Integrated filters

The filter functions necessary for stereo and SAP demodulation and part of the dbx filter circuits are provided on-chip using transistor circuits. The required filter accuracy is attained by an automatic filter alignment circuit.

## I<sup>2</sup>C-bus controlled BTSC stereo/SAP decoder

TDA9850

### Adjustment procedure

#### COMPOSITE INPUT LEVEL ADJUSTMENT

Feed in from FM demodulator the composite signal with 100% modulation (25 kHz deviation) L + R;  $f_i = 300$  Hz. Set input level control via I<sup>2</sup>C-bus monitoring OUTL or OUTR (500 mV  $\pm$ 20 mV). Store the setting in a non-volatile memory.

#### AUTOMATIC ADJUSTMENT PROCEDURE

- Connect 2.2  $\mu$ F capacitors from ACR and ACL to ground.
- Composite input signal L = 300 Hz, R = 3.1 kHz, 14% modulation for each channel.
- Mode selection setting bits: STEREO = 1, SAP = 0 (see Table 8).
- Start adjustment by transmission ADJ = 1 in register ALI3. The decoder will align itself.
- After 1 second minimum stop alignment by transmitting ADJ = 0 in register ALI3 read the alignment data by an I<sup>2</sup>C-bus read operation from ALR1 and ALR2 (see Chapter "I<sup>2</sup>C-bus protocol") and store it in a non-volatile memory. The alignment procedure overwrites the previous data stored in ALI1 and ALI2.
- The capacitors from ACR and ACL may be disconnected after alignment.

#### MANUAL ADJUSTMENT

Manual adjustment is necessary when no dual tone generator is available (e.g. for service).

- Spectral and wideband data have to be set to 10000 (middle position for adjustment range)
- Composite input L = 300 Hz; 14% modulation
- Adjust channel separation by varying wideband data
- Composite input L = 3 kHz; 14% modulation
- Adjust channel separation by varying spectral data
- Iterative spectral/wideband operation for optimum adjustment
- Store data in non-volatile memory.

After every power-on, the alignment data and the input level adjustment data must be loaded from the non-volatile memory.

#### TIMING CURRENT FOR RELEASE RATE

Due to possible internal and external spreading, the timing current can be adjusted via I<sup>2</sup>C-bus, see Table 9, as recommended by dbx.



I<sup>2</sup>C-bus controlled BTSC stereo/SAP decoder

TDA9850

**LIMITING VALUES**

In accordance with the Absolute Maximum Rating System (IEC 134).

SYMBOL	PARAMETER	CONDITIONS	MIN.	MAX.	UNIT
V <sub>CC</sub>	supply voltage		0	10	V
V <sub>V<sub>CAP</sub></sub>	voltage of V <sub>CAP</sub> to GND		0	V <sub>CC</sub>	V
V <sub>VEO</sub>	voltage of VEO to GND		0	1/2 V <sub>CC</sub>	V
V <sub>SDA</sub>	voltage of SDA to GND		0	8.5	V
V <sub>SCL</sub>	voltage of SCL to GND		0	8.5	V
V <sub>n</sub>	voltage of all other pins to GND	V <sub>CC</sub> ≥ 8.5 V	0	8.5	V
		V <sub>CC</sub> < 8.5 V	0	V <sub>CC</sub>	V
T <sub>amb</sub>	operating ambient temperature	T <sub>j</sub> < 125 °C	-20	+70	°C
T <sub>stg</sub>	storage temperature		-65	+150	°C
V <sub>es</sub>	electrostatic handling	HBM; note 1			

**Note**

- Human Body Model (HBM): C = 100 pF; R = 1.5 kΩ; V = 2 kV; charge device model: C = 200 pF; R = 0 Ω; V = 300 V.

**THERMAL CHARACTERISTICS**

SYMBOL	PARAMETER	VALUE	UNIT
R <sub>th j-a</sub>	thermal resistance from junction to ambient in free air		
	SOT232-1	55	K/W
	SOT287-1	68	K/W

I<sup>2</sup>C-bus controlled BTSC stereo/SAP decoder

TDA9850

## REQUIREMENTS FOR THE COMPOSITE INPUT SIGNAL TO ENSURE CORRECT SYSTEM PERFORMANCE

SYMBOL	PARAMETER	CONDITIONS	MIN.	TYP.	MAX.	UNIT
COMP <sub>L+R(rms)</sub>	composite input level for 100% modulation L + R (25 kHz deviation); RMS value; f <sub>i</sub> = 300 Hz	measured at COMP	162	250	363	mV
ΔCOMP	composite input level spreading under operating conditions	T <sub>amb</sub> = -20 to +70 °C; aging; power supply influence	-0.5	-	+0.5	dB
Z <sub>source</sub>	source impedance	note 1	-	low-ohmic	5	kΩ
f <sub>lf</sub>	low frequency roll-off	25 kHz deviation L + R; -2 dB	-	-	5	Hz
f <sub>hf</sub>	high frequency roll-off	25 kHz deviation L + R; -2 dB	100	-	-	kHz
THD <sub>L,R</sub>	total harmonic distortion L + R	f <sub>i</sub> = 1 kHz; 25 kHz deviation	-	-	0.5	%
		f <sub>i</sub> = 1 kHz; 125 kHz deviation; note 2	-	-	1.5	%
S/N	signal-to-noise ratio L + R/noise	CCIR 468-2 weighted quasi peak; L + R; 25 kHz deviation; f <sub>i</sub> = 1 kHz; 75 μs de-emphasis				
	critical picture modulation; note 3		44	-	-	dB
	with sync only		54	-	-	dB
α <sub>SB</sub>	side band suppression mono into unmodulated SAP carrier; SAP carrier/side band	mono signal: 25 kHz deviation, f <sub>i</sub> = 1 kHz; side band: SAP carrier frequency ±1 kHz	40	-	-	dB
α <sub>SP</sub>	spectral spurious attenuation L + R/spurious	50 Hz to 100 kHz; mainly n × f <sub>H</sub> ; no de-emphasis; L + R; 25 kHz deviation, f = 1 kHz as reference				
	n = 1, 4, 5, 6		35	-	-	dB
	n = 2, 3		26	-	-	dB

## Notes

1. Low-ohmic preferred, otherwise the signal loss and spreading at COMP, caused by Z<sub>O</sub> and the composite input impedance (see Chapter "Characteristics"; row head "Input level adjustment control") must be taken into account.
2. In order to prevent clipping at over-modulation (maximum deviation in the BTSC system for 100% modulation is 73 kHz).
3. For example colour bar or flat field white; 100% video modulation.

I<sup>2</sup>C-bus controlled BTSC stereo/SAP decoder

TDA9850

**CHARACTERISTICS**

All voltages are measured relative to GND;  $V_{CC} = 9\text{ V}$ ;  $R_s = 600\ \Omega$ ;  $R_L = 10\ \text{k}\Omega$ ; AC-coupled;  $C_L = 2.5\ \text{nF}$ ;  $f_i = 1\ \text{kHz}$ ;  $T_{\text{amb}} = +25\ ^\circ\text{C}$ ; see Fig.1; unless otherwise specified.

SYMBOL	PARAMETER	CONDITIONS	MIN.	TYP.	MAX.	UNIT
<b>Supply</b>						
$V_{CC}$	supply voltage		8.5	9	9.5	V
$V_{\text{ripple(p-p)}}$	allowed supply voltage ripple (peak-to-peak value)	$f_i = 50\ \text{Hz to } 100\ \text{kHz}$	–	–	100	mV
$I_{CC}$	supply current		–	58	75	mA
$V_{\text{ref}}$	internal reference voltage at pin $V_{\text{ref}}$		–	3.7	–	V
$\alpha_{\text{ct}}$	crosstalk between bus inputs and signal outputs	notes 1 and 2	–	110	–	dB
<b>Input level adjustment control</b>						
$G_{\text{LA}}$	input level adjustment control		–3.5	–	+4.0	dB
$G_{\text{step}}$	step resolution		–	0.5	–	dB
$V_{i(\text{rms})}$	maximum input voltage level (RMS value)		2	–	–	V
$Z_i$	input impedance		29.5	35	40.5	k $\Omega$
<b>Stereo decoder</b>						
$MPX_{\text{L+R}}$	input voltage level for 100% modulation L + R; 25 kHz deviation (RMS value)	input level adjusted via I <sup>2</sup> C-bus (L + R; $f_i = 300\ \text{Hz}$ ); monitoring OUTL or OUTR	–	250	–	mV
$MPX_{\text{L-R}}$	input voltage level for 100% modulation L – R; 50 kHz deviation (peak value)		–	707	–	mV
$MPX_{(\text{max})}$	maximum headroom for L + R, L, R	$f_{\text{mod}} < 15\ \text{kHz}$ ; THD < 15%	9	–	–	dB
$MPX_{\text{pilot}}$	nominal stereo pilot voltage level (RMS value)		–	50	–	mV
$ST_{\text{on(rms)}}$	pilot threshold voltage stereo on (RMS value)	data STS = 1	–	–	35	mV
		data STS = 0	–	–	30	mV
$ST_{\text{off(rms)}}$	pilot threshold voltage stereo off (RMS value)	data STS = 1	15	–	–	mV
		data STS = 0	10	–	–	mV
Hys	hysteresis		–	2.5	–	dB
$OUT_{\text{L+R}}$	output voltage level for 100% modulation L + R at OUTL, OUTR	input level adjusted via I <sup>2</sup> C-bus (L + R; $f_i = 300\ \text{Hz}$ ); monitoring OUTL or OUTR	480	500	520	mV

I<sup>2</sup>C-bus controlled BTSC stereo/SAP decoder

TDA9850

SYMBOL	PARAMETER	CONDITIONS	MIN.	TYP.	MAX.	UNIT
$\alpha_{cs}$	stereo channel separation L/R	aligned with dual tone 14% modulation for each channel; see Section "Adjustment procedure"				
		$f_L = 300 \text{ Hz}; f_R = 3 \text{ kHz}$	25	35	–	dB
		$f_L = 300 \text{ Hz}; f_R = 8 \text{ kHz}$	20	30	–	dB
		$f_L = 300 \text{ Hz};$ $f_R = 10 \text{ kHz}$	15	25	–	dB
$f_{L,R}$	L, R frequency response	14% modulation; $f_{ref} = 300 \text{ Hz}$ L or R				
		$f_i = 50 \text{ Hz}$ to 10 kHz	–3	–	–	dB
		$f_i = 12 \text{ kHz}$	–	–3	–	dB
THD <sub>L,R</sub>	total harmonic distortion L, R	modulation L or R 1% to 100%; $f_i = 1 \text{ kHz}$	–	0.2	1.0	%
S/N	signal-to-noise ratio	mono mode; CCIR 468-2 weighted; quasi peak; 500 mV output signal	50	60	–	dB
<b>Stereo decoder, oscillator (VCXO); note 3</b>						
$f_o$	nominal VCXO output frequency ( $32f_H$ )	with nominal ceramic resonator	–	503.5	–	kHz
$f_{of}$	spread of free-running frequency	with nominal ceramic resonator	500.0	–	507.0	kHz
$\Delta f_H$	capture range frequency (nominal pilot)		$\pm 190$	$\pm 265$	–	Hz
<b>SAP demodulator; note 4</b>						
SAP <sub>i(rms)</sub>	nominal SAP carrier input voltage level (RMS value)	15 kHz frequency deviation of intercarrier	–	150	–	mV
SAP <sub>on(rms)</sub>	threshold voltage SAP on (RMS value)		–	–	68	mV
SAP <sub>off(rms)</sub>	threshold voltage SAP off (RMS value)		28	–	–	mV
SAP <sub>hys</sub>	hysteresis		–	2	–	dB
SAP <sub>LEV</sub>	SAP output voltage level at OUTL, OUTR	mode selector in position SAP/SAP; $f_{mod} = 300 \text{ Hz};$ 100% modulation	–	500	–	mV
$f_{res}$	frequency response	14% modulation; 50 Hz to 8 kHz; $f_{ref} = 300 \text{ Hz}$	–3	–	–	dB
THD	total harmonic distortion	$f_i = 1 \text{ kHz}$	–	0.5	2.0	%

I<sup>2</sup>C-bus controlled BTSC stereo/SAP decoder

TDA9850

SYMBOL	PARAMETER	CONDITIONS	MIN.	TYP.	MAX.	UNIT
<b>SAP output</b>						
Z <sub>o</sub>	output impedance		–	80	120	Ω
V <sub>O</sub>	DC output voltage		–	0.5V <sub>CC</sub> –1.5	–	V
R <sub>L</sub>	output load resistance (AC-coupled)		5	–	–	kΩ
C <sub>L</sub>	output load capacitance		–	–	2.5	nF
V <sub>o(rms)</sub>	nominal output voltage (RMS value)	150 μs de-emphasis	see Fig.3			
<b>Outputs OUTL and OUTR</b>						
V <sub>o(rms)</sub>	nominal output voltage (RMS value)	100% modulation	–	500	–	mV
HEAD <sub>o</sub>	output headroom		9	–	–	dB
Z <sub>o</sub>	output impedance		–	80	120	Ω
V <sub>O</sub>	DC output voltage		0.45V <sub>CC</sub> –1.5	0.5V <sub>CC</sub> –1.5	0.55V <sub>CC</sub> –1.5	V
R <sub>L</sub>	output load resistance (AC-coupled)		5	–	–	kΩ
C <sub>L</sub>	output load capacitance		–	–	2.5	nF
α <sub>ct</sub>	crosstalk L, R into SAP	100% modulation; f <sub>i</sub> = 1 kHz; L or R; mode selector switched to SAP/SAP	50	75	–	dB
	crosstalk SAP into L, R	100% modulation; f <sub>i</sub> = 1 kHz; SAP; mode selector switched to stereo	50	70	–	dB
ΔV <sub>ST-SAP</sub>	output voltage difference if switched from L, R to SAP	250 Hz to 6.3 kHz	–	–	3	dB
<b>Dbx noise reduction circuit</b>						
t <sub>adj</sub>	stereo adjustment time	see Section "Adjustment procedure"	–	–	1	s
I <sub>s</sub>	nominal timing current for nominal release rate of spectral RMS detector	I <sub>s</sub> can be measured at pin C <sub>TS</sub> via current meter connected to ½V <sub>CC</sub> + 0.25 V	–	24	–	μA
ΔI <sub>s</sub>	spread of timing current		–15	–	+15	%
I <sub>s</sub> range	timing current range	7 steps via I <sup>2</sup> C-bus	–	±30	–	%
I <sub>t</sub>	timing current for release rate of wideband RMS detector		–	⅓I <sub>s</sub>	–	μA
Rel <sub>rate</sub>	nominal RMS detector release rate wideband spectral	nominal timing current and external capacitor values	–	125	–	dB/s
			–	381	–	dB/s

I<sup>2</sup>C-bus controlled BTSC stereo/SAP decoder

TDA9850

SYMBOL	PARAMETER	CONDITIONS	MIN.	TYP.	MAX.	UNIT
<b>Noise detector</b>						
f <sub>0</sub>	noise band-pass centre frequency	composite input level 100 mV (RMS)	–	185	–	kHz
Q	quality factor		–	6	–	–
Ster1, SAP1	lowest noise threshold for stereo off respectively SAP off (RMS value; see Tables 11 and 12)	f <sub>i</sub> = 185 kHz	17	24	34	mV
Ster16, SAP16	highest noise threshold for stereo off respectively SAP off (RMS value)	f <sub>i</sub> = 185 kHz	210	290	400	mV
ΔSter, ΔSAP	noise threshold step width	f <sub>i</sub> = 185 kHz	0	1.5	3	dB
<b>Power-on reset; note 5</b>						
V <sub>RESET(STA)</sub>	start of reset voltage	increasing supply voltage	–	–	2.5	V
		decreasing supply voltage	4.2	5	5.8	V
V <sub>RESET(END)</sub>	end of reset voltage	increasing supply voltage	5.2	6	6.8	V
<b>Digital part (I<sup>2</sup>C-bus pins); note 6</b>						
V <sub>IH</sub>	HIGH level input voltage		3	–	8.5	V
V <sub>IL</sub>	LOW level input voltage		–0.3	–	+1.5	V
I <sub>IH</sub>	HIGH level input current		–10	–	+10	μA
I <sub>IL</sub>	LOW level input current		–10	–	+10	μA
V <sub>OL</sub>	LOW level output voltage	I <sub>IL</sub> = 3 mA	–	–	0.4	V

**Notes to the characteristics**

- Crosstalk:  $20 \log \frac{V_{bus(p-p)}}{V_{o(rms)}}$
- The transmission contains:
  - Total initialization with MAD and SAD for volume and 11 DATA words, see also definition of characteristics
  - Clock frequency = 50 kHz
  - Repetition burst rate = 400 Hz
  - Maximum bus signal amplitude = 5 V (p-p).
- The oscillator is designed to operate together with MURATA resonator CSB503F58 or CSB503JF958 as SMD. Change of the resonator supplier is possible, but the resonator specification must be close to the specified ones.
- The internal SAP carrier level is determined by the composite input level and the level adjustment gain.
- When reset is active the SMU-bit (SAP mute) and the LMU-bit (OUTL, OUTR mute) is set and the I<sup>2</sup>C-bus receiver is in the reset position.
- The AC characteristics are in accordance with the I<sup>2</sup>C-bus specification for standard mode (clock frequency maximum 100 kHz). A higher frequency, up to 280 kHz, can be used if all clock and data times are interpolated between standard mode (100 kHz) and fast mode (400 kHz) in accordance with the I<sup>2</sup>C-bus specification. Information about the I<sup>2</sup>C-bus can be found in brochure "I<sup>2</sup>C-bus and how to use it" (order number 9398 393 40011).

I<sup>2</sup>C-bus controlled BTSC stereo/SAP decoder

TDA9850

**I<sup>2</sup>C-BUS PROTOCOL****I<sup>2</sup>C-bus format to read (slave transmits data)**

S	SLAVE ADDRESS	R/W	A	DATA	MA	DATA	P
---	---------------	-----	---	------	----	------	---

**Table 1** Explanation of I<sup>2</sup>C-bus format to read (slave transmits data)

NAME	DESCRIPTION
S	START condition; generated by the master
Standard SLAVE ADDRESS (MAD)	1011011 pin MAD not connected
Pin programmable SLAVE ADDRESS	1011010 pin MAD connected to ground
R/W	1 (read); generated by the master
A	acknowledge; generated by the slave
DATA	slave transmits an 8-bit data word
MA	acknowledge; generated by the master
P	STOP condition; generated by the master

**Table 2** Definition of the transmitted bytes after read condition

FUNCTION	BYTE	MSB								LSB	
		D7	D6	D5	D4	D3	D2	D1	D0		
Alignment read 1	ALR1	Y	SAPP	STP	A14	A13	A12	A11	A10		
Alignment read 2	ALR2	Y	SAPP	STP	A24	A23	A22	A21	A20		

**Table 3** Function of the bits in Table 2

BITS	FUNCTION
STP	stereo pilot identification (stereo received = 1)
SAPP	SAP pilot identification (SAP received = 1)
A1X to A2X	stereo alignment read data
A1X	for wideband expander
A2X	for spectral expander
Y	indefinite

The master generates an acknowledge when it has received the first data word, ALR1, then the slave transmits the next data word ALR2. The master next generates an acknowledge, then slave begins transmitting the first data word ALR1, and so on until the master generates no acknowledge and transmits a STOP condition.

I<sup>2</sup>C-bus controlled BTSC stereo/SAP decoder

TDA9850

I<sup>2</sup>C-bus format to write (slave receives data)

S	SLAVE ADDRESS	R/W	A	SUBADDRESS	A	DATA	A	P
---	---------------	-----	---	------------	---	------	---	---

**Table 4** Explanation of I<sup>2</sup>C-bus format to write (slave receives data)

NAME	DESCRIPTION
S	START condition
Standard SLAVE ADDRESS (MAD)	101 101 1 pin MAD not connected
Pin programmable SLAVE ADDRESS	101 101 0 pin MAD connected to ground
R/W	0 (write)
A	acknowledge; generated by the slave
SUBADDRESS (SAD)	see Table 5
DATA	see Table 6
P	STOP condition

If more than 1 byte of DATA is transmitted, then auto-increment is performed, starting from the transmitted subaddress and auto-increment of subaddress in accordance with the order of Table 5 is performed.

**Table 5** Subaddress second byte after MAD

FUNCTION	REGISTER	MSB								LSB
		D7	D6	D5	D4	D3	D2	D1	D0	
Control 1	CON1	0	0	0	0	0	1	0	0	
Control 2	CON2	0	0	0	0	0	1	0	1	
Control 3	CON3	0	0	0	0	0	1	1	0	
Control 4	CON4	0	0	0	0	0	1	1	1	
Alignment 1	ALI1	0	0	0	0	1	0	0	0	
Alignment 2	ALI2	0	0	0	0	1	0	0	1	
Alignment 3	ALI3	0	0	0	0	1	0	1	0	

**Table 6** Definition of third byte, third byte after MAD and SAD

FUNCTION	REGISTER	MSB								LSB
		D7	D6	D5	D4	D3	D2	D1	D0	
Control 1	CON1	0	0	0	0	ST3	ST2	ST1	ST0	
Control 2	CON2	0	0	0	0	SP3	SP2	SP1	SP0	
Control 3	CON3	SAP	STEREO	0	SMU	LMU	0	0	0	
Control 4	CON4	0	0	0	0	L3	L2	L1	L0	
Alignment 1	ALI1	0	0	0	A14	A13	A12	A11	A10	
Alignment 2	ALI2	STS	0	0	A24	A23	A22	A21	A20	
Alignment 3	ALI3	ADJ	0	0	0	0	TC2	TC1	TC0	



I<sup>2</sup>C-bus controlled BTSC stereo/SAP decoder

TDA9850

**Table 7** Function of the bits in Table 6

BITS	FUNCTION
ST0 to ST3	noise threshold for stereo
SP0 to SP3	noise threshold for SAP
STEREO, SAP	mode selection
LMU	mute control OUTL and OTR
SMU	mute control SAP
L0 to L3	input level adjustment
ADJ	stereo adjustment on/off
A1X to A2X	stereo alignment data
A1X	for wideband expander
A2X	for spectral expander
TC0 to TC2	timing current alignment data
STS	stereo level switch

**Table 8** Mode selection

FUNCTION MODE AT		DATA TRANSMISSION STATUS INTERNAL SWITCH, READABLE BITS: STP, SAPP	SETTING BITS	
OUTL	OUTR		STEREO	SAP
SAP	SAP	SAP received	1	1
Mute	mute	no SAP received	1	1
Left	right	STEREO received	1	0
Mono	mono	no STEREO received	1	0
Mono	SAP	SAP received	0	1
Mono	mute	no SAP received	0	1
Mono	mono	independent	0	0

**Table 9** Timing current setting

FUNCTION I <sub>s</sub> RANGE	DATA		
	TC2	TC1	TC0
+30%	1	0	0
+20%	1	0	1
+10%	1	1	1
Nominal	0	1	1
-10%	0	1	0
-20%	0	0	1
-30%	0	0	0

I<sup>2</sup>C-bus controlled BTSC stereo/SAP decoder

TDA9850

**Table 10** Level adjust setting

G <sub>L</sub> (dB)	DATA			
	L3	L2	L1	L0
+4.0	1	1	1	1
+3.5	1	1	1	0
+3.0	1	1	0	1
+2.5	1	1	0	0
+2.0	1	0	1	1
+1.5	1	0	1	0
+1.0	1	0	0	1
+0.5	1	0	0	0
0.0	0	1	1	1
-0.5	0	1	1	0
-1.0	0	1	0	1
-1.5	0	1	0	0
-2.0	0	0	1	1
-2.5	0	0	1	0
-3.0	0	0	0	1
-3.5	0	0	0	0

**Table 11** Stereo noise threshold (Ster)

THRESHOLD	DATA			
	ST3	ST2	ST1	ST0
Ster1	0	0	0	0
Ster2	0	0	0	1
Ster3	0	0	1	0
Ster4	0	0	1	1
Ster5	0	1	0	0
Ster6	0	1	0	1
Ster7	0	1	1	0
Ster8	0	1	1	1
Ster9	1	0	0	0
Ster10	1	0	0	1
Ster11	1	0	1	0
Ster12	1	0	1	1
Ster13	1	1	0	0
Ster14	1	1	0	1
Ster15	1	1	1	0
Ster16	1	1	1	1

**Table 12** SAP noise threshold (SAP)

THRESHOLD	DATA			
	SP3	SP2	SP1	SP0
SAP1	0	0	0	0
SAP2	0	0	0	1
SAP3	0	0	1	0
SAP4	0	0	1	1
SAP5	0	1	0	0
SAP6	0	1	0	1
SAP7	0	1	1	0
SAP8	0	1	1	1
SAP9	1	0	0	0
SAP10	1	0	0	1
SAP11	1	0	1	0
SAP12	1	0	1	1
SAP13	1	1	0	0
SAP14	1	1	0	1
SAP15	1	1	1	0
SAP16	1	1	1	1

**Table 13** ADJ bit setting

FUNCTION	DATA
Stereo decoder operation mode	0
Auto adjustment of channel separation	1

**Table 14** STS bit setting (pilot threshold stereo on)

FUNCTION	DATA
ST <sub>on</sub> ≤ 35 mV	1
ST <sub>on</sub> ≤ 30 mV	0

**Table 15** Mute setting

FUNCTION	DATA LMU	FUNCTION	DATA SMU
Forced mute at OUTR, OUTL	1	forced mute at SAP	1
No forced mute at OUTR, OUTL	0	no forced mute at SAP	0

I<sup>2</sup>C-bus controlled BTSC stereo/SAP decoder

## TDA9850

**Table 16** Alignment data for expander in read register ALR1 and ALR2 and in write register ALI1 and ALI2

FUNCTION	DATA				
	D4 AX4	D3 AX3	D2 AX2	D1 AX1	D0 AX0
Gain increase	1	1	1	1	1
	1	1	1	1	0
	1	1	1	0	1
	1	1	1	0	0
	1	1	0	1	1
	1	1	0	1	0
	1	1	0	0	1
	1	1	0	0	0
	1	0	1	1	1
	1	0	1	1	0
	1	0	1	0	1
	1	0	1	0	0
	1	0	0	1	1
	1	0	0	1	0
	1	0	0	0	1
Nominal gain	1	0	0	0	0
	0	1	1	1	1
Gain decrease	0	1	1	1	0
	0	1	1	0	1
	0	1	1	0	0
	0	1	0	1	1
	0	1	0	1	0
	0	1	0	0	1
	0	1	0	0	0
	0	0	1	1	1
	0	0	1	1	0
	0	0	1	0	1
	0	0	0	1	0
	0	0	0	1	1
	0	0	0	1	0
	0	0	0	0	1
	0	0	0	0	0

I<sup>2</sup>C-bus controlled BTSC stereo/SAP decoder

TDA9850

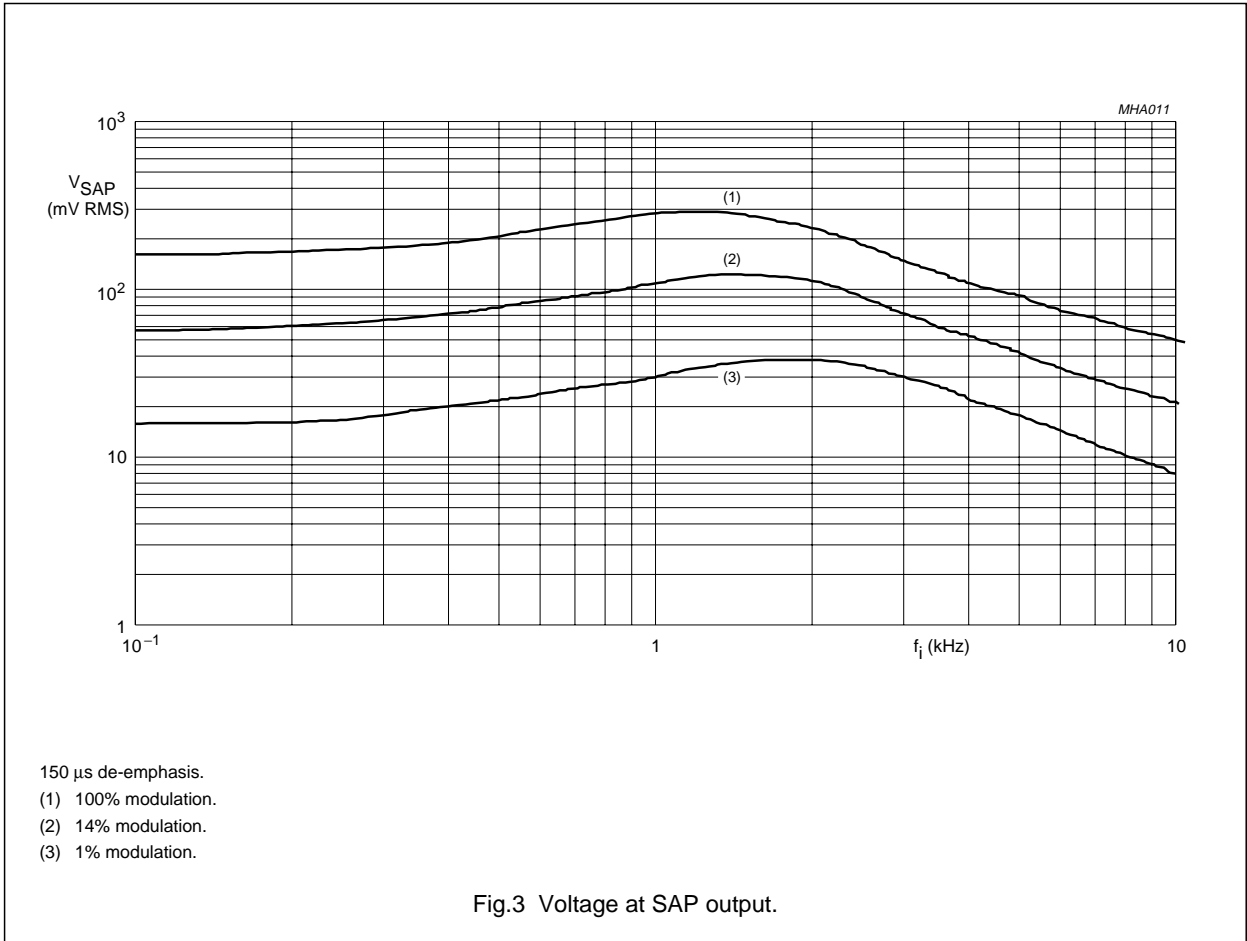

I<sup>2</sup>C-bus controlled BTSC stereo/SAP decoder

TDA9850

INTERNAL PIN CONFIGURATIONS

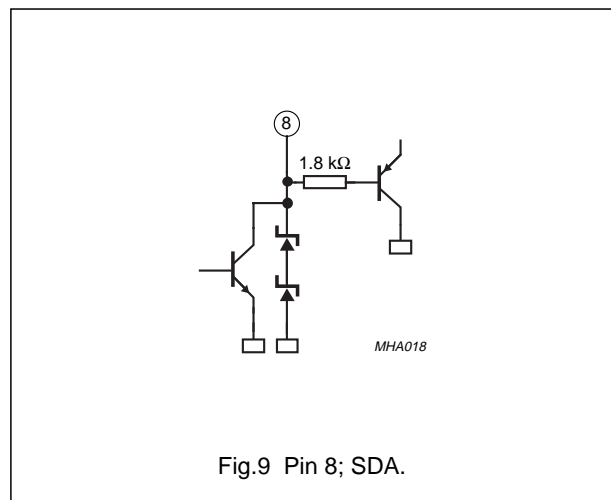
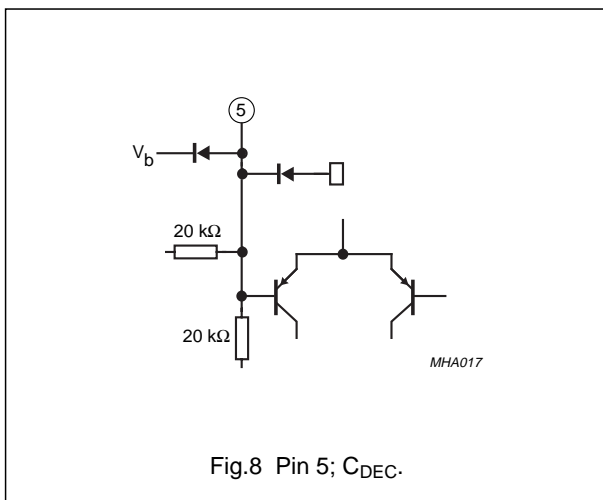
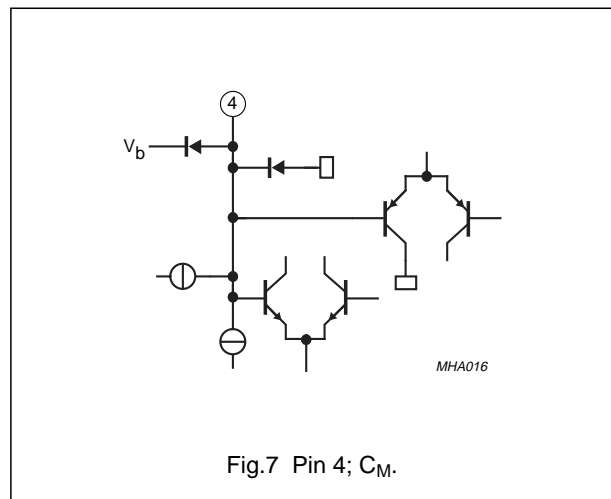
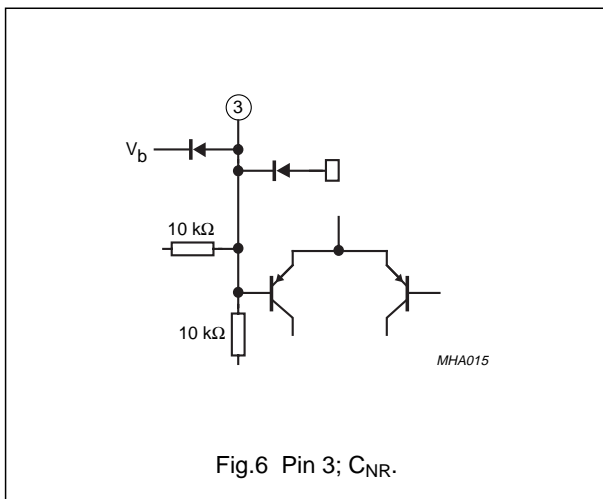
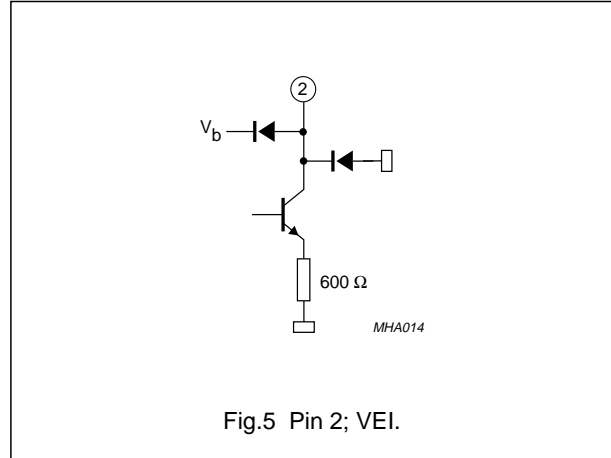
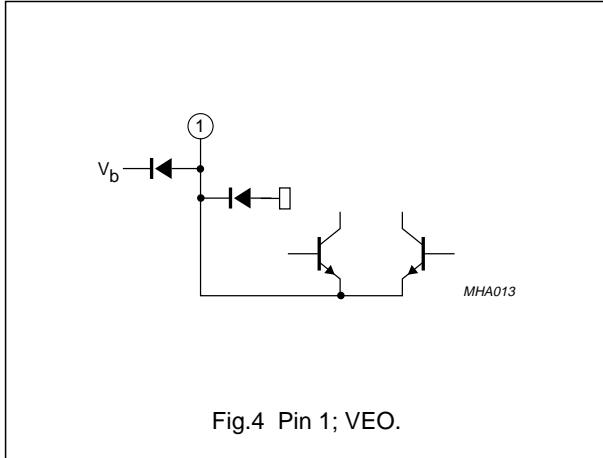

I<sup>2</sup>C-bus controlled BTSC stereo/SAP decoder

TDA9850

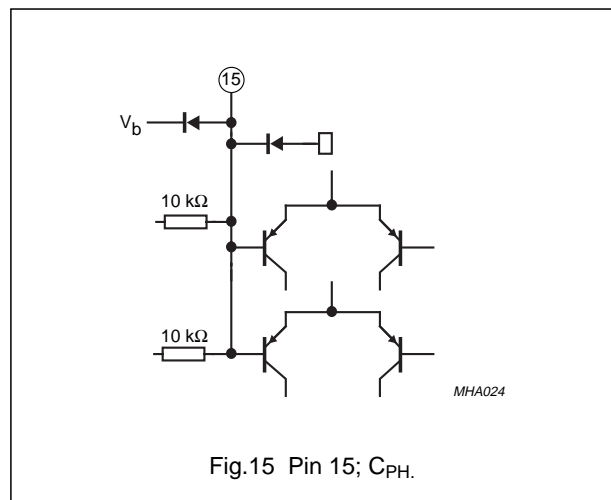
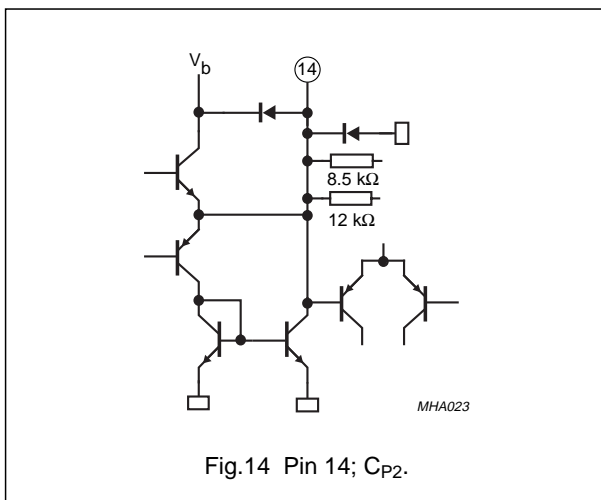
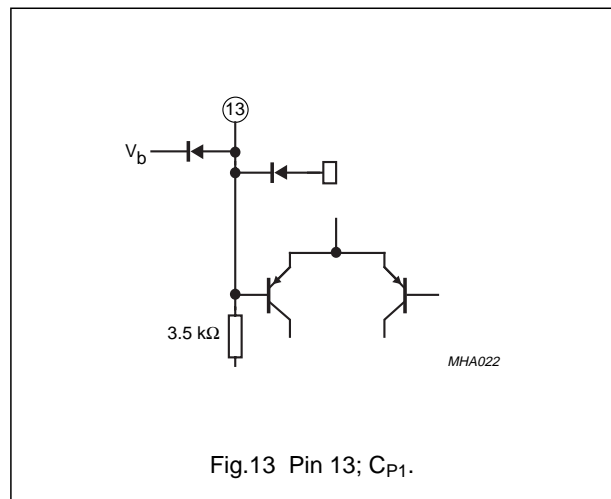
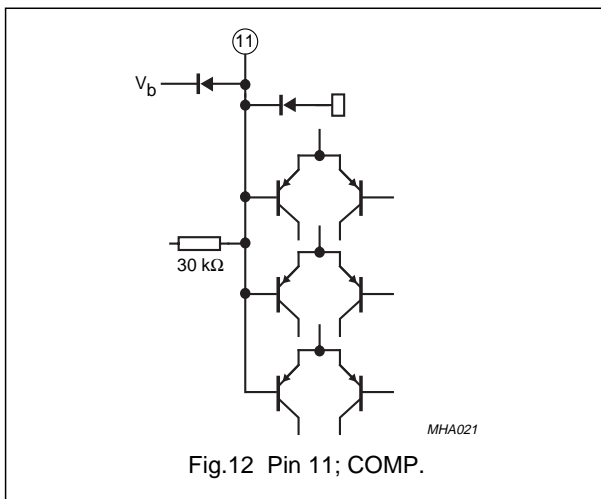
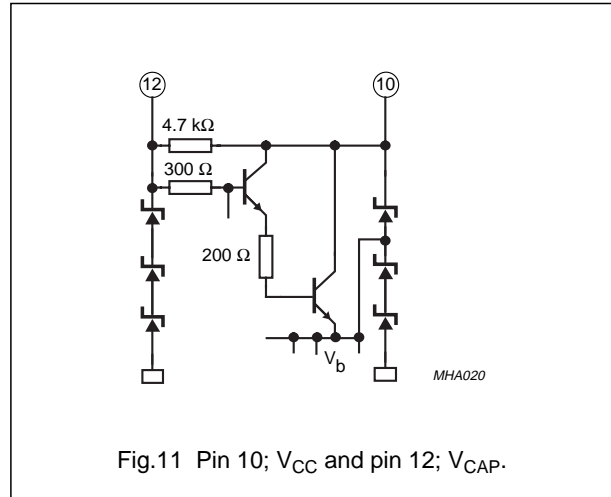
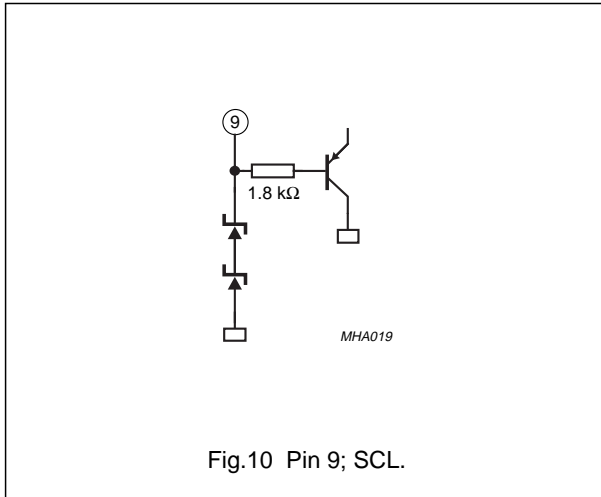

I<sup>2</sup>C-bus controlled BTSC stereo/SAP decoder

TDA9850

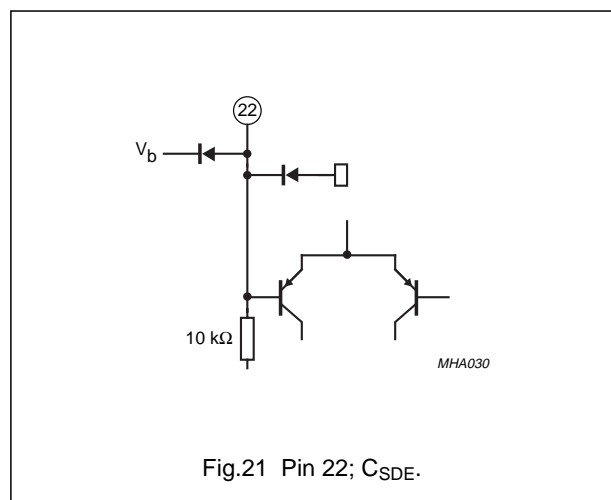
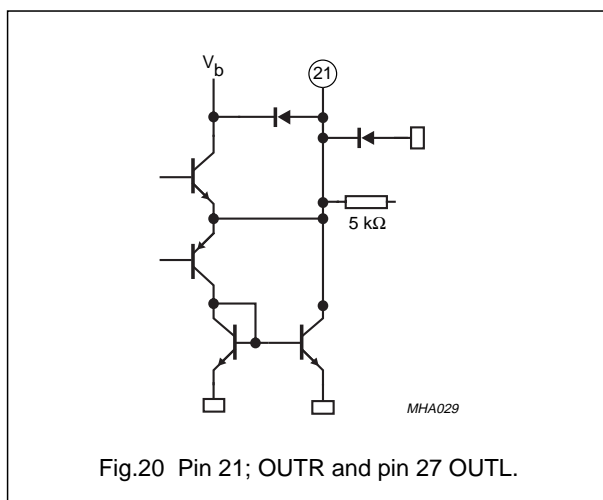
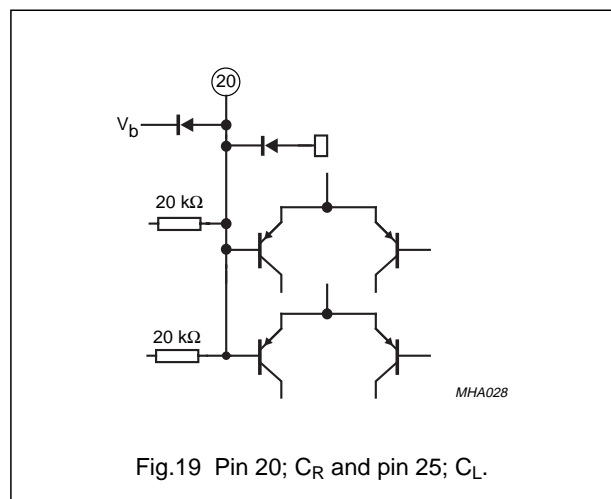
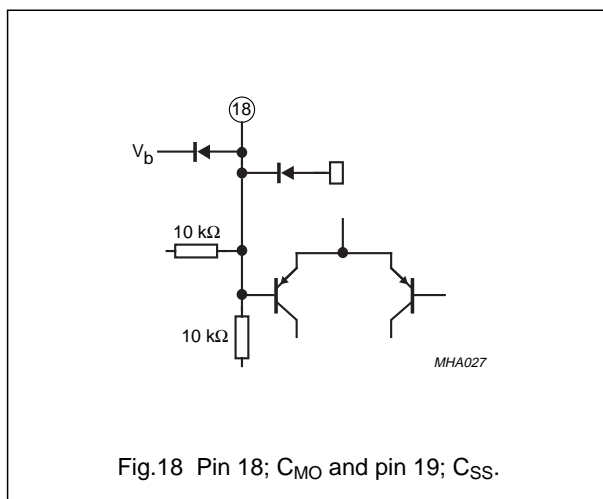
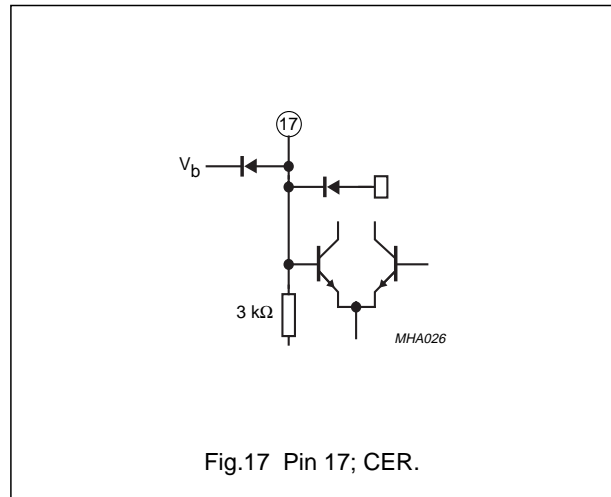
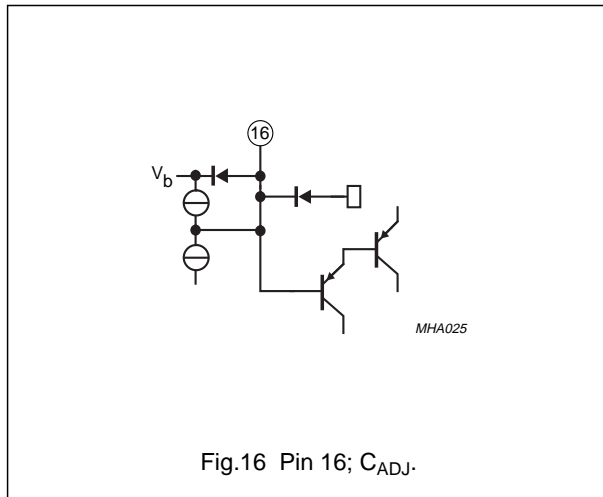

I<sup>2</sup>C-bus controlled BTSC stereo/SAP decoder

TDA9850

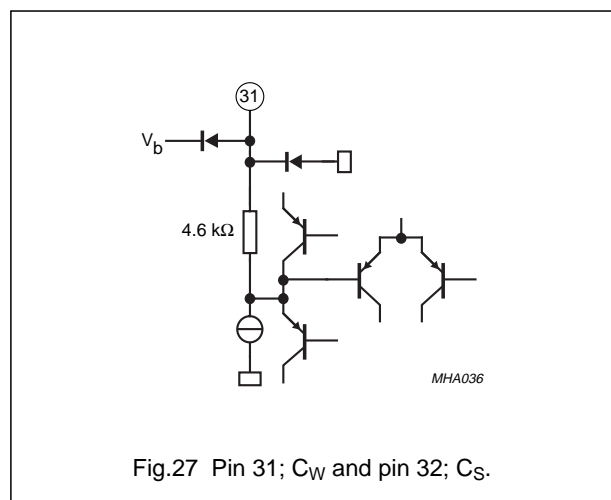
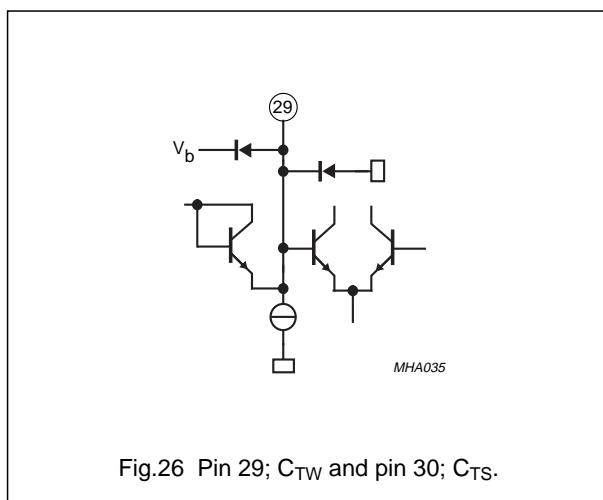
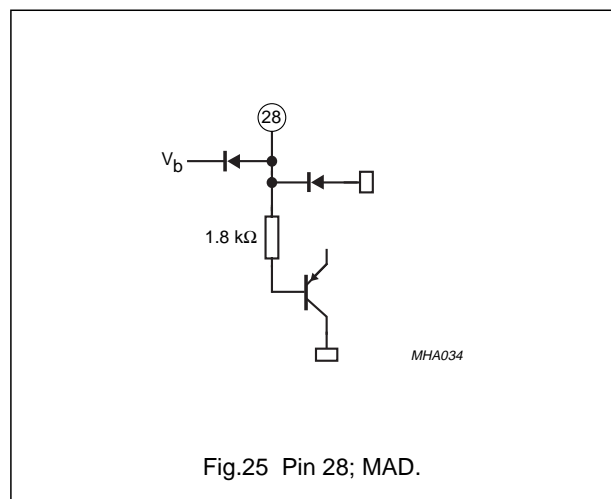
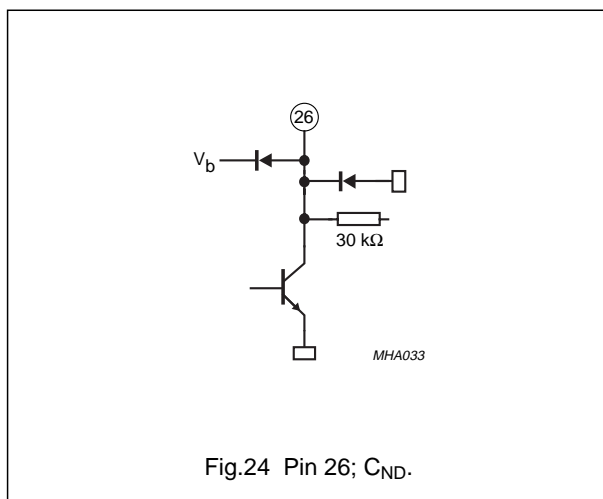
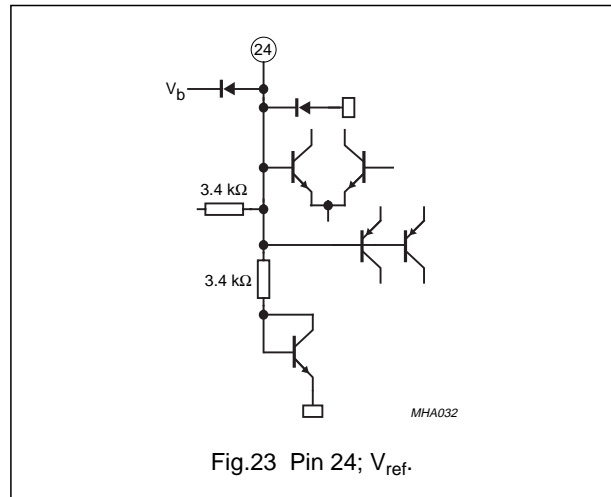
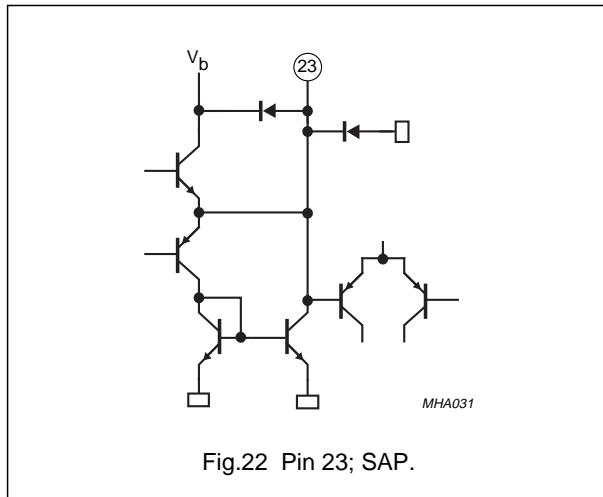



I<sup>2</sup>C-bus controlled BTSC stereo/SAP decoder

TDA9850

PACKAGE OUTLINES

SDIP32: plastic shrink dual in-line package; 32 leads (400 mil)

SOT232-1

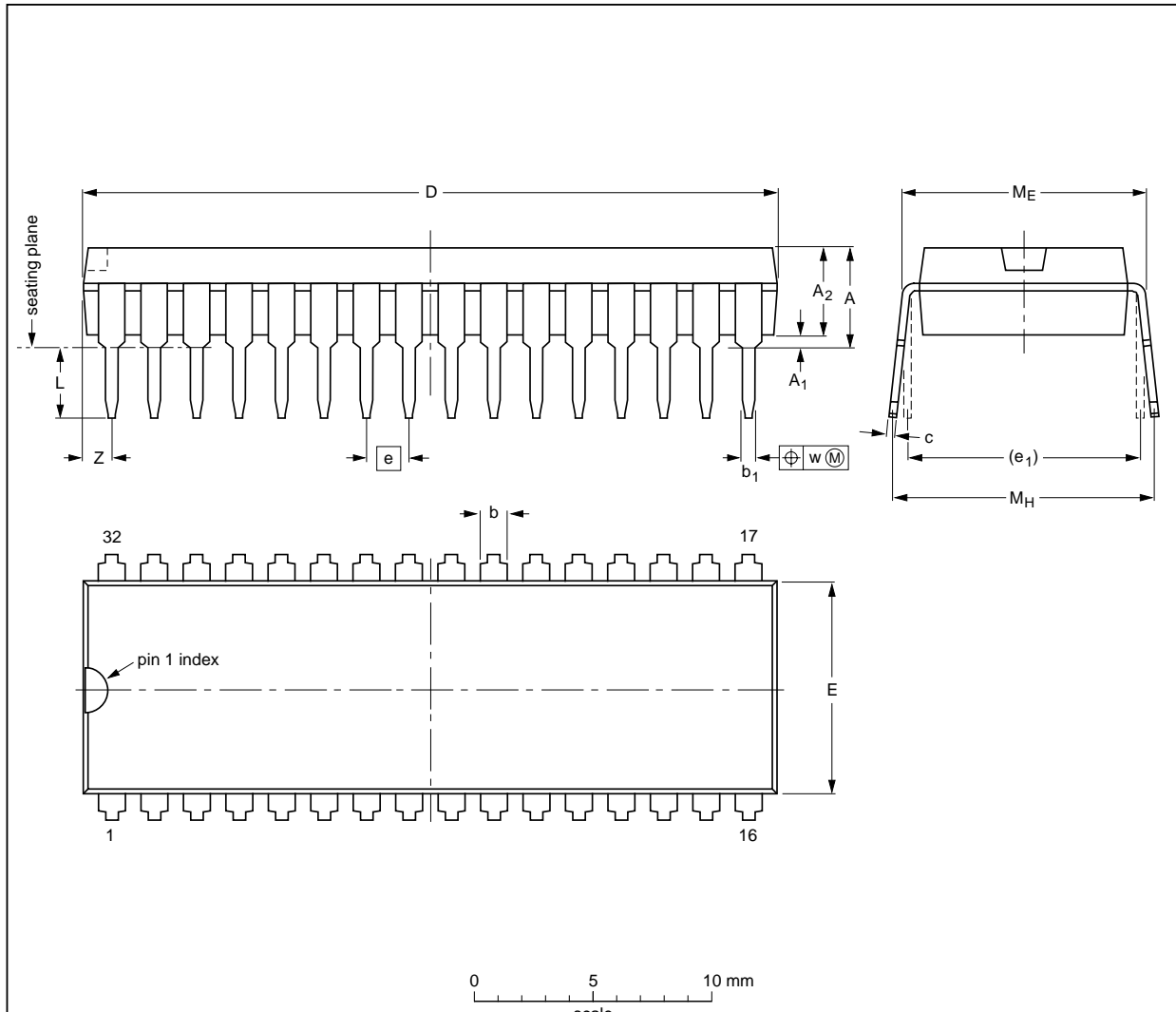

DIMENSIONS (mm are the original dimensions)

UNIT	A max.	A <sub>1</sub> min.	A <sub>2</sub> max.	b	b <sub>1</sub>	c	D <sup>(1)</sup>	E <sup>(1)</sup>	e	e <sub>1</sub>	L	M <sub>E</sub>	M <sub>H</sub>	w	Z <sup>(1)</sup> max.
mm	4.7	0.51	3.8	1.3 0.8	0.53 0.40	0.32 0.23	29.4 28.5	9.1 8.7	1.778	10.16	3.2 2.8	10.7 10.2	12.2 10.5	0.18	1.6

Note

1. Plastic or metal protrusions of 0.25 mm maximum per side are not included.

OUTLINE VERSION	REFERENCES				EUROPEAN PROJECTION	ISSUE DATE
	IEC	JEDEC	EIAJ			
SOT232-1						92-11-17 95-02-04

I<sup>2</sup>C-bus controlled BTSC stereo/SAP decoder

TDA9850

SO32: plastic small outline package; 32 leads; body width 7.5 mm

SOT287-1

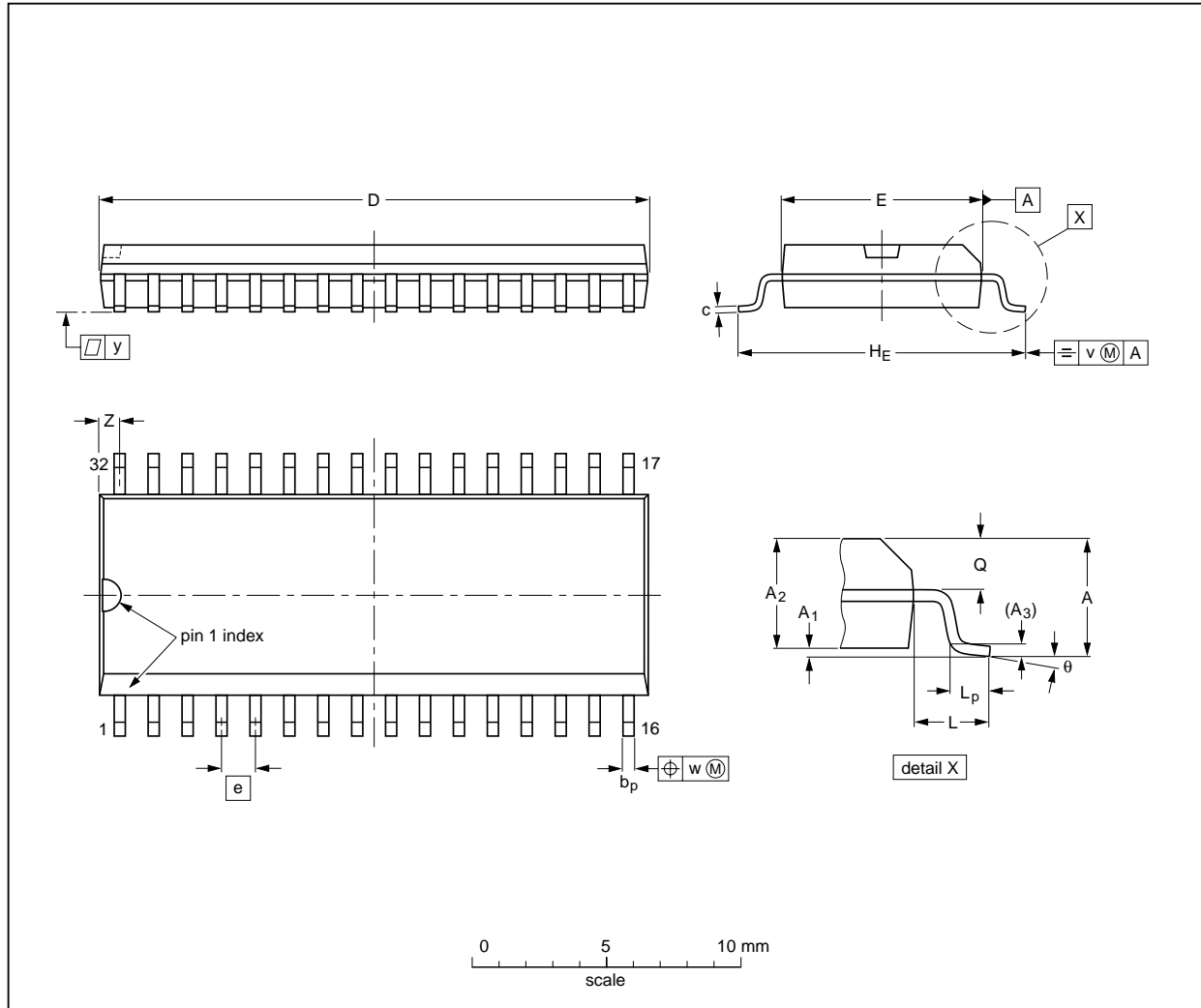

DIMENSIONS (inch dimensions are derived from the original mm dimensions)

UNIT	A max.	A <sub>1</sub>	A <sub>2</sub>	A <sub>3</sub>	b <sub>p</sub>	c	D <sup>(1)</sup>	E <sup>(1)</sup>	e	H <sub>E</sub>	L	L <sub>p</sub>	Q	v	w	y	Z <sup>(1)</sup>	θ
mm	2.65	0.3 0.1	2.45 2.25	0.25	0.49 0.36	0.27 0.18	20.7 20.3	7.6 7.4	1.27	10.65 10.00	1.4	1.1 0.4	1.2 1.0	0.25	0.25	0.1	0.95 0.55	8° 0°
inches	0.10	0.012 0.004	0.096 0.086	0.01	0.02 0.01	0.011 0.007	0.81 0.80	0.30 0.29	0.050	0.419 0.394	0.055	0.043 0.016	0.047 0.039	0.01	0.01	0.004	0.037 0.022	

Note

1. Plastic or metal protrusions of 0.15 mm maximum per side are not included.

OUTLINE VERSION	REFERENCES				EUROPEAN PROJECTION	ISSUE DATE
	IEC	JEDEC	EIAJ			
SOT287-1						95-01-25 97-05-22

## I<sup>2</sup>C-bus controlled BTSC stereo/SAP decoder

TDA9850

### SOLDERING DIP, SDIP, HDIP, DBS and SIL

#### Introduction

There is no soldering method that is ideal for all IC packages. Wave soldering is often preferred when through-hole and surface mounted components are mixed on one printed-circuit board. However, wave soldering is not always suitable for surface mounted ICs, or for printed-circuits with high population densities. In these cases reflow soldering is often used.

This text gives a very brief insight to a complex technology. A more in-depth account of soldering ICs can be found in our *"IC Package Databook"* (order code 9398 652 90011).

#### Soldering by dip or wave

The maximum permissible temperature of the solder is 260 °C; solder at this temperature must not be in contact with the joint for more than 5 seconds. The total contact time of successive solder waves must not exceed 5 seconds.

The device may be mounted to the seating plane, but the temperature of the plastic body must not exceed the specified storage maximum. If the printed-circuit board has been pre-heated, forced cooling may be necessary immediately after soldering to keep the temperature within the permissible limit.

#### Repairing soldered joints

Apply a low voltage soldering iron (less than 24 V) to the lead(s) of the package, below the seating plane or not more than 2 mm above it. If the temperature of the soldering iron bit is less than 300 °C it may remain in contact for up to 10 seconds. If the bit temperature is between 300 and 400 °C, contact may be up to 5 seconds.

### SOLDERING SO

#### Introduction

There is no soldering method that is ideal for all IC packages. Wave soldering is often preferred when through-hole and surface mounted components are mixed on one printed-circuit board. However, wave soldering is not always suitable for surface mounted ICs, or for printed-circuits with high population densities. In these cases reflow soldering is often used.

This text gives a very brief insight to a complex technology. A more in-depth account of soldering ICs can be found in our *"IC Package Databook"* (order code 9398 652 90011).

#### Reflow soldering

Reflow soldering techniques are suitable for all SO packages.

Reflow soldering requires solder paste (a suspension of fine solder particles, flux and binding agent) to be applied to the printed-circuit board by screen printing, stencilling or pressure-syringe dispensing before package placement.

Several techniques exist for reflowing; for example, thermal conduction by heated belt. Dwell times vary between 50 and 300 seconds depending on heating method. Typical reflow temperatures range from 215 to 250 °C.

Preheating is necessary to dry the paste and evaporate the binding agent. Preheating duration: 45 minutes at 45 °C.

#### Wave soldering

Wave soldering techniques can be used for all SO packages if the following conditions are observed:

- A double-wave (a turbulent wave with high upward pressure followed by a smooth laminar wave) soldering technique should be used.
- The longitudinal axis of the package footprint must be parallel to the solder flow.
- The package footprint must incorporate solder thieves at the downstream end.

During placement and before soldering, the package must be fixed with a droplet of adhesive. The adhesive can be applied by screen printing, pin transfer or syringe dispensing. The package can be soldered after the adhesive is cured.

Maximum permissible solder temperature is 260 °C, and maximum duration of package immersion in solder is 10 seconds, if cooled to less than 150 °C within 6 seconds. Typical dwell time is 4 seconds at 250 °C.

A mildly-activated flux will eliminate the need for removal of corrosive residues in most applications.

#### Repairing soldered joints

Fix the component by first soldering two diagonally-opposite end leads. Use only a low voltage soldering iron (less than 24 V) applied to the flat part of the lead. Contact time must be limited to 10 seconds at up to 300 °C. When using a dedicated tool, all other leads can be soldered in one operation within 2 to 5 seconds at between 270 and 320 °C.

I<sup>2</sup>C-bus controlled BTSC stereo/SAP decoder

TDA9850

**DEFINITIONS**

<b>Data sheet status</b>	
Objective specification	This data sheet contains target or goal specifications for product development.
Preliminary specification	This data sheet contains preliminary data; supplementary data may be published later.
Product specification	This data sheet contains final product specifications.
<b>Limiting values</b>	
Limiting values given are in accordance with the Absolute Maximum Rating System (IEC 134). Stress above one or more of the limiting values may cause permanent damage to the device. These are stress ratings only and operation of the device at these or at any other conditions above those given in the Characteristics sections of the specification is not implied. Exposure to limiting values for extended periods may affect device reliability.	
<b>Application information</b>	
Where application information is given, it is advisory and does not form part of the specification.	

**LIFE SUPPORT APPLICATIONS**

These products are not designed for use in life support appliances, devices, or systems where malfunction of these products can reasonably be expected to result in personal injury. Philips customers using or selling these products for use in such applications do so at their own risk and agree to fully indemnify Philips for any damages resulting from such improper use or sale.

**PURCHASE OF PHILIPS I<sup>2</sup>C COMPONENTS**

Purchase of Philips I<sup>2</sup>C components conveys a license under the Philips' I<sup>2</sup>C patent to use the components in the I<sup>2</sup>C system provided the system conforms to the I<sup>2</sup>C specification defined by Philips. This specification can be ordered using the code 9398 393 40011.

---

I<sup>2</sup>C-bus controlled BTSC stereo/SAP decoder

TDA9850

---

**NOTES**

---

I<sup>2</sup>C-bus controlled BTSC stereo/SAP decoder

TDA9850

---

**NOTES**

---

I<sup>2</sup>C-bus controlled BTSC stereo/SAP decoder

TDA9850

---

**NOTES**

## Philips Semiconductors – a worldwide company

**Argentina:** IEROD, Av. Juramento 1992 - 14.b, (1428)  
BUENOS AIRES, Tel. (541)786 7633, Fax. (541)786 9367

**Australia:** 34 Waterloo Road, NORTH RYDE, NSW 2113,  
Tel. (02)805 4455, Fax. (02)805 4466

**Austria:** Triester Str. 64, A-1101 WIEN, P.O. Box 213,  
Tel. (01)60 101-1236, Fax. (01)60 101-1211

**Belgium:** Postbus 90050, 5600 PB EINDHOVEN, The Netherlands,  
Tel. (31)40 783 749, Fax. (31)40 788 399

**Brazil:** Rua do Rocio 220 - 5<sup>th</sup> floor, Suite 51,  
CEP: 04552-903-SÃO PAULO-SP, Brazil.  
P.O. Box 7383 (01064-970),  
Tel. (011)821-2333, Fax. (011)829-1849

**Canada:** PHILIPS SEMICONDUCTORS/COMPONENTS:  
Tel. (800) 234-7381, Fax. (708) 296-8556

**Chile:** Av. Santa Maria 0760, SANTIAGO,  
Tel. (02)773 816, Fax. (02)777 6730

**Colombia:** IPRELENZO LTDA, Carrera 21 No. 56-17,  
77621 BOGOTÁ, Tel. (571)249 7624/(571)217 4609,  
Fax. (571)217 4549

**Denmark:** Prags Boulevard 80, PB 1919, DK-2300  
COPENHAGEN S, Tel. (032)88 2636, Fax. (031)57 1949

**Finland:** Sinikallontie 3, FIN-02630 ESPOO,  
Tel. (358)0-615 800, Fax. (358)0-61580 920

**France:** 4 Rue du Port-aux-Vins, BP317,  
92156 SURESNES Cedex,  
Tel. (01)4099 6161, Fax. (01)4099 6427

**Germany:** P.O. Box 10 63 23, 20043 HAMBURG,  
Tel. (040)3296-0, Fax. (040)3296 213.

**Greece:** No. 15, 25th March Street, GR 17778 TAVROS,  
Tel. (01)4894 339/4894 911, Fax. (01)4814 240

**Hong Kong:** PHILIPS HONG KONG Ltd., 15/F Philips Ind. Bldg.,  
24-28 Kung Yip St., KWAI CHUNG, N.T.,  
Tel. (852)424 5121, Fax. (852)480 6960/480 6009

**India:** Philips INDIA Ltd, Shivsagar Estate, A Block,  
Dr. Annie Besant Rd. Worli, Bombay 400 018  
Tel. (022)4938 541, Fax. (022)4938 722

**Indonesia:** Philips House, Jalan H.R. Rasuna Said Kav. 3-4,  
P.O. Box 4252, JAKARTA 12950,  
Tel. (021)5201 122, Fax. (021)5205 189

**Ireland:** Newstead, Clonskeagh, DUBLIN 14,  
Tel. (01)7640 000, Fax. (01)7640 200

**Italy:** PHILIPS SEMICONDUCTORS S.r.l.,  
Piazza IV Novembre 3, 20124 MILANO,  
Tel. (0039)2 6752 2531, Fax. (0039)2 6752 2557

**Japan:** Philips Bldg 13-37, Kohnan2-chome, Minato-ku, TOKYO 108,  
Tel. (03)3740 5130, Fax. (03)3740 5077

**Korea:** Philips House, 260-199 Itaewon-dong,  
Yongsan-ku, SEOUL, Tel. (02)709-1412, Fax. (02)709-1415

**Malaysia:** No. 76 Jalan Universiti, 46200 PETALING JAYA,  
SELANGOR, Tel. (03)750 5214, Fax. (03)757 4880

**Mexico:** 5900 Gateway East, Suite 200, EL PASO, TX 79905,  
Tel. 9-5(800)234-7381, Fax. (708)296-8556

**Netherlands:** Postbus 90050, 5600 PB EINDHOVEN, Bldg. VB  
Tel. (040)783749, Fax. (040)788399

**New Zealand:** 2 Wagener Place, C.P.O. Box 1041, AUCKLAND,  
Tel. (09)849-4160, Fax. (09)849-7811

**Norway:** Box 1, Manglerud 0612, OSLO,  
Tel. (022)74 8000, Fax. (022)74 8341

**Pakistan:** Philips Electrical Industries of Pakistan Ltd.,  
Exchange Bldg. ST-2/A, Block 9, KDA Scheme 5, Clifton,  
KARACHI 75600, Tel. (021)587 4641-49,  
Fax. (021)577035/5874546

**Philippines:** PHILIPS SEMICONDUCTORS PHILIPPINES Inc,  
106 Valero St. Salcedo Village, P.O. Box 2108 MCC, MAKATI,  
Metro MANILA, Tel. (02)810 0161, Fax. (02)817 3474

**Portugal:** PHILIPS PORTUGUESA, S.A.,  
Rua dr. António Loureiro Borges 5, Arquiparque - Miraflores,  
Apartado 300, 2795 LINDA-A-VELHA,  
Tel. (01)4163160/4163333, Fax. (01)4163174/4163366

**Singapore:** Lorong 1, Toa Payoh, SINGAPORE 1231,  
Tel. (65)350 2000, Fax. (65)251 6500

**South Africa:** S.A. PHILIPS Pty Ltd.,  
195-215 Main Road Martindale, 2092 JOHANNESBURG,  
P.O. Box 7430, Johannesburg 2000,  
Tel. (011)470-5911, Fax. (011)470-5494.

**Spain:** Balmes 22, 08007 BARCELONA,  
Tel. (03)301 6312, Fax. (03)301 42 43

**Sweden:** Kottbygatan 7, Akalla. S-164 85 STOCKHOLM,  
Tel. (0)8-632 2000, Fax. (0)8-632 2745

**Switzerland:** Allmendstrasse 140, CH-8027 ZÜRICH,  
Tel. (01)488 2211, Fax. (01)481 77 30

**Taiwan:** PHILIPS TAIWAN Ltd., 23-30F, 66, Chung Hsiao West  
Road, Sec. 1. Taipei, Taiwan ROC, P.O. Box 22978,  
TAIPEI 100, Tel. (02)388 7666, Fax. (02)382 4382

**Thailand:** PHILIPS ELECTRONICS (THAILAND) Ltd.,  
209/2 Sanpavuth-Bangna Road Prakanong,  
Bangkok 10260, THAILAND,  
Tel. (662)398-0141, Fax. (662)398-3319

**Turkey:** Talatpasa Cad. No. 5, 80640 GÜLTEPE/ISTANBUL,  
Tel. (0212)279 27 70, Fax. (0212)282 67 07

**United Kingdom:** Philips Semiconductors LTD.,  
276 Bath Road, Hayes, MIDDLESEX UB3 5BX,  
Tel. (0181)730-5000, Fax. (0181)754-8421

**United States:** 811 East Arques Avenue, SUNNYVALE,  
CA 94088-3409, Tel. (800)234-7381, Fax. (708)296-8556

**Uruguay:** Coronel Mora 433, MONTEVIDEO,  
Tel. (02)70-4044, Fax. (02)92 0601

**Internet:** <http://www.semiconductors.philips.com/ps/>

**For all other countries apply to:** Philips Semiconductors,  
International Marketing and Sales, Building BE-p,  
P.O. Box 218, 5600 MD EINDHOVEN, The Netherlands,  
Telex 35000 phtncl, Fax. +31-40-724825

SCD40 © Philips Electronics N.V. 1995

All rights are reserved. Reproduction in whole or in part is prohibited without the prior written consent of the copyright owner.

The information presented in this document does not form part of any quotation or contract, is believed to be accurate and reliable and may be changed without notice. No liability will be accepted by the publisher for any consequence of its use. Publication thereof does not convey nor imply any license under patent- or other industrial or intellectual property rights.

Printed in The Netherlands

533061/1500/01/pp32  
Document order number:

Date of release: 1995 Jun 19  
9397 750 00176