

# DATA SHEET



## **TDA9178**

YUV one chip picture improvement  
based on luminance vector-, colour  
vector- and spectral processor

Preliminary specification  
File under Integrated Circuits, IC02

1999 Sep 24



# YUV one chip picture improvement based on luminance vector-, colour vector- and spectral processor

TDA9178

## FEATURES

- Picture content dependent non-linear Y, U and V processing by luminance histogram analysis
- Variable gamma control
- Adaptive black and white stretch control
- Skin tone correction
- Green enhancement
- Blue stretch
- Luminance Transient Improvement (LTI)
- Smart peaking for detail enhancement
- Colour Transient Improvement (CTI)
- SCAn VELOCITY Modulation (SCAVEM) output
- Line Width Control (LWC)
- Video Dependent Coring (VDC)
- Colour Dependent Sharpness (CDS)
- Noise measurement
- Feature Mode (FM) detector
- Cue Flash (CF) detector
- Three additional pins for access to 6-bit ADC and I<sup>2</sup>C-bus
- Adjustable chrominance delay
- TV standard independent
- I<sup>2</sup>C-bus controlled
- 1f<sub>H</sub> and 2f<sub>H</sub>
- DEMonstration MOde (DEMO).

## GENERAL DESCRIPTION

The TDA9178 is a transparent analog video processor with YUV input and output interfaces. It offers three main functions: luminance vector processing, colour vector processing and spectral processing. Beside these three main functions, there are some additional functions.

In the luminance vector processor, the luminance transfer function is controlled in a non-linear way by the distribution, in 5 discrete histogram sections, of the luminance values measured in a picture. As a result, the contrast ratio of the most important parts of the scene will be improved. Black restoration is available in the event of a set-up in the luminance signal.

A variable gamma function, after the histogram conversion, offers the possibilities of alternative brightness control or factory adjustment of the picture tube.



The adaptive black stretch function of the TDA9178 offers the possibility of having a larger 'weight' for the black parts of the video signal; the white stretch function offers an additional overall gain for increased light production.

To maintain a proper colour reproduction, the saturation of the U- and V-colour difference signals is also controlled as a function of the actual non-linearity in the luminance channel.

In the colour vector processor, the dynamic skin tone correction locally changes the hue of colours that match skin tones to the correct hue. The green enhancement circuit activates medium saturated green towards to more saturated green. The blue stretch circuit can be activated which shifts colours near white towards blue.

The spectral processor provides 1D luminance transient improvement, luminance detail enhancement by smart peaking and a 1 D colour transient improvement. The TDA9178 can be used as a cost effective alternative to (but also in combination with) scan velocity modulation.

In the spectral processor line width control (or aperture control) can be user defined. The TDA9178 is capable of adjusting the amount of coring according to the video level with the video dependent coring. The TDA9178 is also capable to give extra sharpness in the cases of saturated red and magenta parts of the screen using the colour dependent sharpness feature.

An embedded noise detector measures noise during the field retrace in parts which are expected to be free from video or text information. With the noise detector a variety of 'smart noise control' architectures can be set up.

A feature mode detector is available for detecting signal sources like VCR (in still picture mode) that re-insert the levels of the retrace part. For this kind of signals the noise measurement of the TDA9178 is not reliable.

An output signal (on the I<sup>2</sup>C-bus and on a separate pin) is available that detects when the picture content has been changed significantly, called cue flash.

An embedded 6-bit ADC can be used for interfacing three analog low frequency voltage signals (e.g. ambient light control or beam current voltage level) to the I<sup>2</sup>C-bus.

# YUV one chip picture improvement based on luminance vector-, colour vector- and spectral processor

TDA9178

In the demonstration mode all the features selected by the user are automatically toggled between on and off.

The TDA9178 concept has a maximum flexibility which can be controlled by the embedded I<sup>2</sup>C-bus. The supply voltage is 8 V. The device is mounted in a 24-lead SDIP package, or in a 24-lead SO package.

## QUICK REFERENCE DATA

SYMBOL	PARAMETER	CONDITIONS	MIN.	TYP.	MAX.	UNIT
V <sub>CC</sub>	supply voltage		7.2	8.0	8.8	V
V <sub>i(Y)</sub>	luminance input voltage (excluding sync)	AMS = 0	–	0.315	0.45	V
		AMS = 1	–	1.0	1.41	V
V <sub>i(UV)</sub>	UV input voltage		–	–	1.9	V
V <sub>FS(ADC)</sub>	full-scale ADC input voltage		–	2.0	–	V

## ORDERING INFORMATION

TYPE NUMBER	PACKAGE		
	NAME	DESCRIPTION	VERSION
TDA9178	SDIP24	plastic shrink dual in-line package; 24 leads (400 mil)	SOT234-1
TDA9178T	SO24	plastic small outline package; 24 leads; body width 7.5 mm	SOT137-1

YUV one chip picture improvement based on luminance vector-, colour vector- and spectral processing

TDA9178

BLOCK DIAGRAM

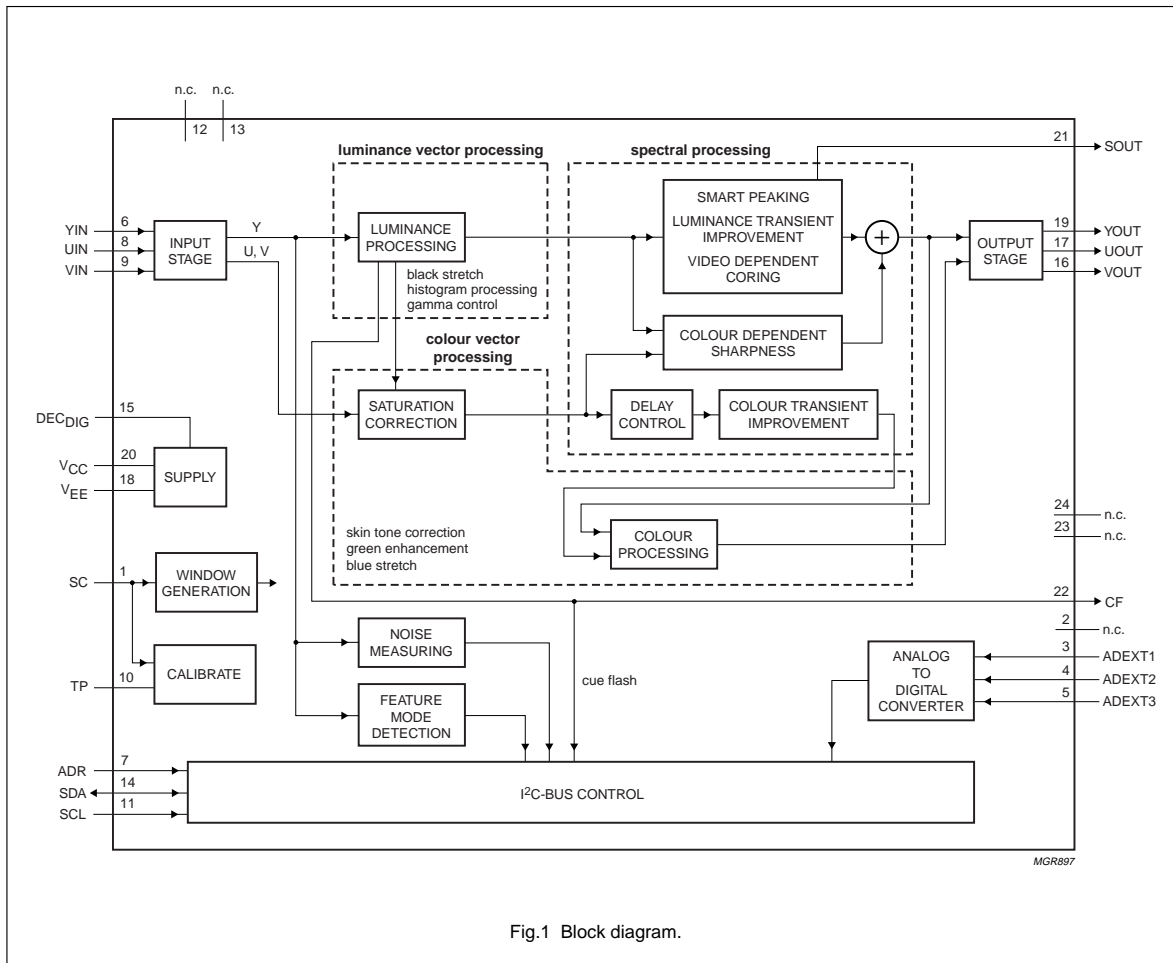

Fig.1 Block diagram.

# YUV one chip picture improvement based on luminance vector-, colour vector- and spectral processor

TDA9178

## PINNING

SYMBOL	PIN	DESCRIPTION
SC	1	sandcastle input
n.c.	2	not connected
ADEXT1	3	ADC input 1
ADEXT2	4	ADC input 2
ADEXT3	5	ADC input 3
YIN	6	luminance input
ADR	7	address selection input
UIN	8	U signal input
VIN	9	V signal input
TP	10	test pin
SCL	11	serial clock input (I <sup>2</sup> C-bus)
n.c.	12	not connected

SYMBOL	PIN	DESCRIPTION
n.c.	13	not connected
SDA	14	serial data input/output (I <sup>2</sup> C-bus)
DEC <sub>DIG</sub>	15	decoupling digital supply
VOUT	16	V signal output
UOUT	17	U signal output
V <sub>EE</sub>	18	ground
YOUT	19	luminance output
V <sub>CC</sub>	20	supply voltage
SOUT	21	SCAVEM output
CF	22	cue flash output
n.c.	23	not connected
n.c.	24	not connected

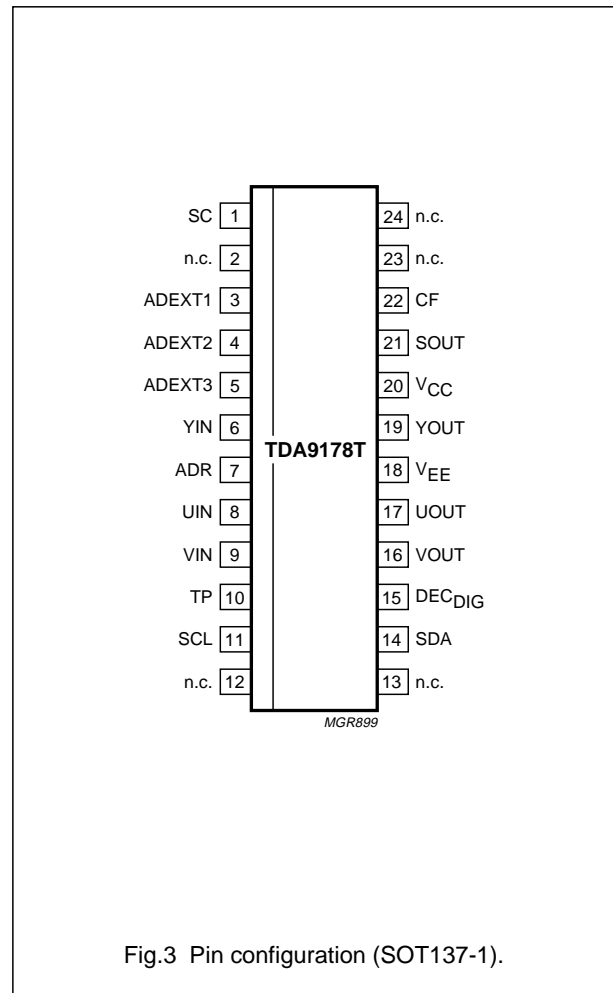
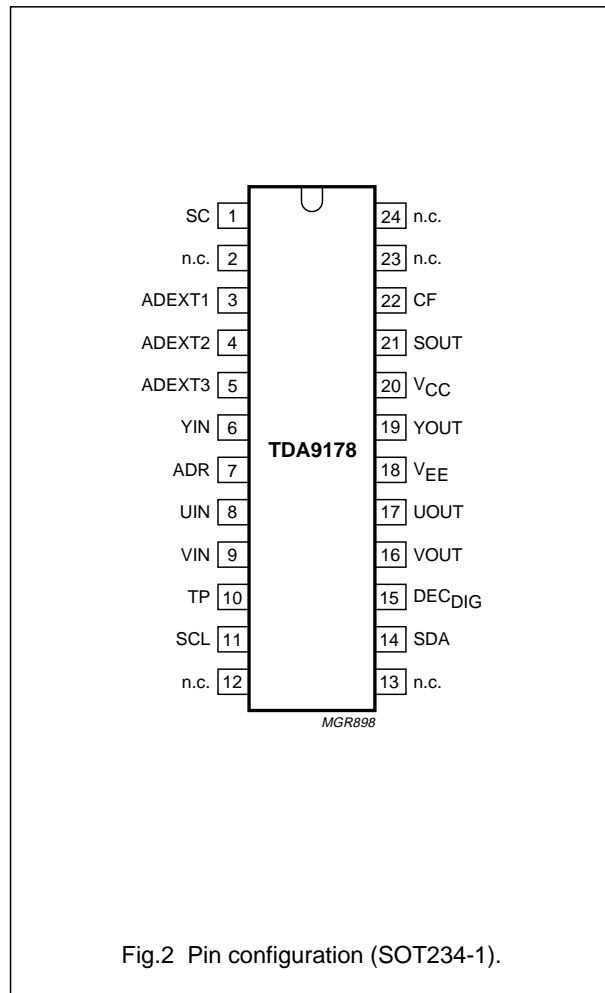

# YUV one chip picture improvement based on luminance vector-, colour vector- and spectral processor

TDA9178

## FUNCTIONAL DESCRIPTION

### Y input selection and amplification

The gain of the luminance input amplifier and output amplifier can be adjusted to signal amplitudes of 0.315 and 1.0 V typically (excluding sync) by I<sup>2</sup>C-bus bit AMS. The sync part is processed transparently to the output, independently of the feature settings.

The Y, U and V input signals are clamped during the burstkey period, defined by the sandcastle reference and should be DC-coupled (the circuit uses internal clamp capacitors). During the clamp pulse (see Figs 7, 8, 9 and 10) an artificial black level is inserted in the Y input signal to correctly preset the internal circuitry.

### Luminance vector processor

In the luminance vector processor the transfer is controlled by a black stretch, the histogram processing and a gamma control circuit. The luminance vector processor also creates the cue flash signal.

#### BLACK STRETCH

A black detector measures and stores the level of the most black part of the scene within an internal defined fixed window in each field into a time constant. The time constant and the response time of the loop are internally fixed. Any difference between this value and the value measured during the clamp is regarded as black offset. In a closed loop offsets until a predefined value of the full-scale value are fed back to the input stage for compensation. The loop gain is a function of the histogram and variable gamma settings. The black offset correction can be switched on and off by the I<sup>2</sup>C-bus bit BON. Related to the corrected black offset the nominal signal amplitude is set again to 100% full scale through an amplitude stretch function. Luminance values beyond full scale are unaffected. Additionally, the measured black offset is also used to set the adaptive black stretch gain (see also Section "Adaptive black stretch").

#### HISTOGRAM PROCESSING

For the luminance signal the histogram distribution is measured in real-time over five segments within an internally defined fixed window in each field. During the period that the luminance is in one segment, a corresponding internal capacitor is loaded by a current source. At the end of the field five segment voltages are stored into on-board memories. The voltages stored in the memories determine the non-linear processing of the luminance signal to achieve a picture with a maximum of information (visible details).

Each field the capacitors are discharged and the measurement starts all over again.

Parts in the scene that do not contribute to the information in that scene, like sub or side titles, should be omitted from the histogram measurement. No measurements are performed outside the internal fixed window period.

Very rapid picture changes, also related to the field interlace, can result in flicker effects. The histogram values are averaged at the field rate thus cancelling the flicker effects.

#### *Adaptive black stretch*

The so-called adaptive black stretch gain is one of the factors that control the gamma of the picture. This gain is controlled by the measured black offset value in the black stretch circuit and the I<sup>2</sup>C-bus adaptive black stretch DAC: bits BT5 to BT0. For pictures with no black offset the black stretch gain equals unity so the gamma is not changed and the DAC setting has no influence. In case of a black offset, the black stretch gain is increased so the gamma of the picture is reduced. This procedure results in a maximum of visible details over the whole range of luminances. However, depending on personal taste, sometimes higher values of gamma are preferred. Therefore the amount of gamma reduction can be adjusted by the DAC.

#### *Adaptive white-point stretching*

For pictures with many details in white parts, the histogram conversion procedure makes a transfer with large gain in the white parts. The amount of light coming out of the scene is reduced accordingly. The white stretcher introduces additional overall gain for increased light production, and so violating the principle of having a full-scale reference. The white-point stretching can be switched on or off by means of the I<sup>2</sup>C-bus bit WPO.

#### *Standard deviation*

For scenes in which segments of the histogram distribution are very dominant with respect to the others, the non-linear amplification should be reduced in comparison to scenes with a flat histogram distribution. The standard deviation detector measures the spread of the histogram distribution and modulates the user setting of the non-linear amplifier.

#### *Non-linear amplifier*

The stored segment voltages determine the individual gain of each segment in such a way that continuity is granted for the complete luminance range.

## YUV one chip picture improvement based on luminance vector-, colour vector- and spectral processor

TDA9178

The maximum and minimum gain of each segment is limited. Apart from the adaptive white-point stretching the black and white references are not affected by the non-linear processing. The amount of non-linearity can be controlled by the I<sup>2</sup>C-bus non-linearity DAC: bits NL5 to NL0.

### VARIABLE GAMMA

On top of the histogram conversion a variable gamma function is applied for an alternative brightness control, or for factory adjustment. It is intended as an alternative for the DC-offset of the classic brightness user control. It maintains the black and white references. The gamma ranges from 0.5 to 1.5. The gamma can be set by the I<sup>2</sup>C-bus variable gamma DAC: bits VG5 to VG0.

### CUE FLASH

In the present TV environment there is a lot of measured information like ambient light and noise. This information can be used to make an update of settings of the several algorithms after a picture has changed. The cue flash signal detects when a picture changes significantly. When the picture content has changed, the I<sup>2</sup>C-bus bit CF is set to logic 1 in the status register. After reading the status register, bit CF is reset to logic 0. On the output pin CF the cue flash information is present (active LOW) for only one line in the vertical retrace part. This pin is configured as an open drain output and therefore should be pulled up to the 5 V supply.

### Spectral processor

In the spectral processor the luminance transfer is controlled by smart peaking, colour dependent sharpness and luminance transient improvement, defined by the sharpness improvement processor. The colour transfer is controlled by a colour transient improvement circuit; an additional output is available to provide a SCAVEM circuit.

### ADJUSTABLE CHROMINANCE DELAY

The colour vector processor drives a delay line for correcting delay errors between the luminance input signal and the chrominance input signals (U and V). The chrominance delay can be adjusted in 6 steps of 12 ns ( $1f_H$ ) or 6 ns ( $2f_H$ ) by the I<sup>2</sup>C-bus bits CD2 to CD0.

### SHARPNESS IMPROVEMENT PROCESSOR

The sharpness improvement processor increases the slope of large luminance transients of vertical objects and enhances transients of details in natural scenes by contour correction.

It comprises three main processing units: the step improvement processor, the contour processor and the smart sharpness controller.

### Transient improvement processor

The step improvement processor (see Fig.11) comprises two main functions:

- MINMAX generator
- MINMAX fader.

The MINMAX generator utilizes all taps of an embedded luminance delay line to calculate the minimum and maximum envelope of all signals momentarily stored in the delay line. The MINMAX fader chooses between the minimum and maximum envelopes, depending on the polarity of a decision signal derived from the contour processor. Figures 12, 13 and 14 show some waveforms of the step improvement processor and illustrate that fast transients result with this algorithm. The MINMAX generator also outputs a signal that represents the momentary envelope of the luminance input signal. This envelope information is used by the smart sharpness controller.

Line width control (also called aperture control) can be performed by I<sup>2</sup>C-bus line width DAC: bits LW5 to LW0. This control can be used to compensate for horizontal geometry errors caused by the gamma, for blooming of the spot of the CRT, or for compensating SCAVEM.

### Contour processor

The contour processor comprises two contour generators with different frequency characteristics. The contour generator generates a second-order derivative of the incoming luminance signal which is supplied to the smart sharpness controller. In the smart sharpness controller, this signal is added to the properly delayed original luminance input signal, making up the peaking signal for detail enhancement. The peaking path features a low peaking frequency of 2 MHz (at  $1f_H$ ), or a high peaking frequency of 3 MHz (at  $1f_H$ ), selectable by I<sup>2</sup>C-bus bit CFS.

The contour generators utilize three taps of the embedded luminance delay line. Figure 15 illustrates the normalized frequency transfer of the filter.

## YUV one chip picture improvement based on luminance vector-, colour vector- and spectral processor

TDA9178

### Smart sharpness controller

The smart sharpness controller (see Fig.16) is a fader circuit that fades between peaked luminance and step-improved luminance, controlled by the output of a step discriminating device known as the step detector. It also contains a variable coring level stage.

The step detector is basically a differentiator, so both amplitude of the step and its slope add to the detection criterion. The smart sharpness controller has four user controls:

- Steepness control, performed by the I<sup>2</sup>C-bus DAC: bits SP5 to SP0
- Peaking control, performed by the I<sup>2</sup>C-bus DAC: bits PK5 to PK0
- Video dependent coring, switched on or switched off by the I<sup>2</sup>C-bus bit VDC
- Coring level control, performed by the I<sup>2</sup>C-bus DAC: bits CR5 to CR0.

The steepness setting controls the amount of steepness in the edge-correction processing path.

The peaking setting controls the amount of contour correction for proper detail enhancement. The envelope signal generated by the step improvement processor modulates the peaking setting in order to reduce the amount of peaking for large sine wave excursions.

With video dependent coring, it is possible to have more reduction of the peaking in the black parts of a scene than in the white parts, and therefore automatically reducing the visibility of the background noise.

The coring setting controls the coring level in the peaking path for rejection of high-frequency noise.

All four settings facilitate reduction of the impact of the sharpness features, e.g. for noisy luminance signals.

### COLOUR DEPENDENT SHARPNESS

The colour dependent sharpness circuit increases the luminance sharpness in saturated red and magenta parts of the screen. Because of the limited bandwidth of the colour signals, there is no need to increase the high frequencies of the colour signals. Instead, the details in the luminance signal will be enhanced. In this circuit a limited number of colours are enhanced (red and magenta). Contrary to normal peaking algorithm, extra gain is applied for low frequencies (2 MHz at  $1f_H$ ). This is needed, because the information that is lacking below 2 MHz (at  $1f_H$ ) is most important. In large coloured parts the normal peaking is still active to enhance the fine details.

The smart peaking algorithm has been designed such that the luminance output amplitude will never exceed 110% of the luminance input signal amplitude. Therefore the normal peaking range (12 dB) will be reduced at large transients, and in case of colour dependent sharpness there is even more reduction.

However, by setting bit OSP (Overrule Smart Peaking) one can undo the extra peaking reduction in case of colour dependant sharpness. It must be emphasized that setting OSP may lead to unwanted large luminance output signals, for instance in details in red coloured objects.

### COLOUR TRANSIENT IMPROVEMENT

The colour transient improvement circuit (see Fig.17) increases the slope of the colour transients of vertical objects. Each channel of the CTI circuit basically consists of two delay cells: an electronic potentiometer and an edge detector circuit that controls the wiper position of the potentiometer. Normally the wiper of the potentiometer will be in position B (mid position), so passing the input signal B to the output with a single delay. The control signal is obtained by the signals A and C.

When an edge occurs the value of the control signal will fade between +1 and -1 and finally will become zero again. A control signal value of +1 fades the wiper in position C, passing the two times delayed input signal to the output. A control signal of -1 fades the wiper in position A, so an undelayed input signal is passed to the output. The result is an output signal which has steeper edges than the input signal. Contrary to other existing CTI algorithms, the transients remain time correct with respect to the luminance signal, as the algorithm steepens edges proportionally, without discontinuity.

### SCAVEM

A luminance output is available for SCAVEM processing. This luminance signal is not affected by the spectral processing functions.

### Colour vector processor

The colour processing part contains skin tone correction, green enhancement and blue stretch. The colour vector processing is dependent on the amplitude and sign of the colour difference signals. Therefore, both the polarity and the nominal amplitude of the colour difference signals are relevant when using the colour vector processor facility.



# YUV one chip picture improvement based on luminance vector-, colour vector- and spectral processor

TDA9178

## SKIN TONE CORRECTION

Skin tones are very sensitive for transmission (hue) errors, because we have an absolute feeling for skin tones. To make a picture look free of hue error, the goal is to make sure that skin tones are put at a correct colour.

The dynamic skin tone correction circuit achieves this goal by instantaneously and locally changing the hue of those colours which are located in the area in the UV plane that matches skin tones (see Fig.4).

The correction is dependent on luminance, saturation and distance to the preferred axis and can be done towards two different angles. The preferred angle can be chosen by bit ASK in the I<sup>2</sup>C-bus settings. The settings are 123° (ASK = 0) and 117° (ASK = 1). The enclosed correction area can be increased to 140% with the I<sup>2</sup>C-bus bit SSK (so-called: Size). The enclosed detection 'angle' of the correcting area can be increased to 160% with the I<sup>2</sup>C-bus bit WSK (so-called: Width). The skin tone correction can be switched on or off with the I<sup>2</sup>C-bus bit DSK.

## GREEN ENHANCEMENT

The green enhancement circuit (see Fig.5) is intended to shift low saturated green colours towards more saturated green colours. This shift is achieved by instantaneously and locally changing those colours which are located in the area in the UV plane that matches low saturated green. The saturation shift is dependent on the luminance, saturation and distance to the detection axis of 208°. The direction of shift in the colour is fixed by hardware. The amount of green enhancement can be increased to 160% by the I<sup>2</sup>C-bus bit GGR. The enclosed detection 'angle' of the correcting area can be increased to 160% with the I<sup>2</sup>C-bus bit WGR (so-called: Width). The enclosed correction area can be increased to 140% with the I<sup>2</sup>C-bus bit SGR (so-called: Size). The green enhancement can be switched on or switched off with the I<sup>2</sup>C-bus bit DGR.

## BLUE STRETCH

The blue stretch circuit (see Fig.6) is intended to shift colours near white towards more blueish coloured white to give a brighter impression. This shift is achieved by instantaneously and locally changing those colours which are located in the area in the UV plane that matches colours near white. The shift is dependent on the luminance and saturation. The direction of shift (towards an angle of 330°) in the colour is fixed by hardware. The amount of blue stretch can be increased to 160% by the I<sup>2</sup>C-bus bit GBL.

The enclosed correction area can be increased to 140% by the I<sup>2</sup>C-bus bit SBL (so-called: Size). The blue stretch can be switched on or off by the I<sup>2</sup>C-bus bit DBL.

## SATURATION CORRECTION

The non-linear luminance processing done by the histogram modification and variable gamma, influences the colour reproduction; mainly the colour saturation. Therefore, the U and V signals are linear processed for saturation compensation.

## Noise measuring

A video line which is supposed to be free from video information ('empty line') is used to measure the amount of noise. The measured RMS value of the noise can be used for reducing several features, by the I<sup>2</sup>C-bus interface, such as luminance vector processing and spectral processing. For the TDA9178 the empty line is chosen three lines after recognition of the vertical blanking from the sandcastle pulse input. Figures 7, 8, 9 and 10 show the measurement locations for different broadcast norms.

The noise detector is capable of measuring the signal-to-noise ratio between -45 and -20 dB. The output scale runs linearly with dB. The noise samples are averaged for over 20 fields to reduce the fluctuations in the measurement process. It is obvious, that for signal sources (like VCR in still picture mode) that re-insert the levels of the retrace part, the measurement is not reliable (see Section "Feature mode detector"). The result of the averaging process will update the contents of the I<sup>2</sup>C-bus register: bits ND5 to ND0 at a rate of 1/32 of the field frequency. If a register access conflict occurs, the data of the noise register is made invalid by setting the flag bit DV (Data Valid) to zero.

## Feature mode detector

A detector is available for detecting signal sources (like VCR in still picture mode) that re-inserted the levels of the retrace part. For this kind of signals the noise measurement of the TDA9178 is not reliable, but this detector sets bit FM in the ND-register to logic 1. For normal video signals bit FM is set to logic 0. This circuit measures transients (like synchronization pulses) on the luminance input during the internal V-pulse. The feature mode detector is setting bit FM to logic 1 when no transients are present during 2 lines in the vertical retrace part over 3 fields (like the synchronization pulses).

# YUV one chip picture improvement based on luminance vector-, colour vector- and spectral processor

TDA9178

## Successive approximation ADC

Pins ADEXT1, ADEXT2 and ADEXT3 are connected to a 6-bit successive approximation ADC via a multiplexer. The multiplexer toggles between the inputs with each field. At each field flyback, a conversion is started for two of the three inputs and the result is stored in the corresponding bus register ADEXT1, ADEXT2 or ADEXT3. The input pin ADEXT1 is updated every field, while input fields ADEXT2 and ADEXT3 are updated once in two consecutive fields (see Figs 7, 8, 9 and 10). Once in 32 fields the ADEXT2 input is not updated, because then the noise measurement is updated.

In this way, any slow varying analog signal can be given access to the I<sup>2</sup>C-bus. If a register access conflict occurs, the data of that register is made invalid by setting the flag bit DV (Data Valid) to zero.

## Smart noise control

With the help of the internal noise detector and a user-preferred noise algorithm, the user can make a fully automatic I<sup>2</sup>C-bus feature reduction, briefly called 'Smart Noise Control'.

## Demonstration mode

By the I<sup>2</sup>C-bus bit DEM all the picture improvement features can be demonstrated in one picture. By setting bit DEM to logic 1, all the features selected by the user are active for 5 s in 1f<sub>H</sub> mode (in 2f<sub>H</sub> mode: 2.5 s), and for another 5 s in 1f<sub>H</sub> mode (in 2f<sub>H</sub> mode: 2.5 s) all features selected are turned off (then the TDA9178 is 'transparent' to the incoming signal).

## Internal window

To determine the histogram levels and the black offset the TDA9178 performs several measurements. An internally defined window serves to exclude parts in the scene like 'subtittling' or 'logos'. The internal window can be regarded as a weighting function which has a value of one within a square near the centre of the screen and which gradually decreases to zero towards the edges.

When bit WLB (Window Letter Box) is made logic 1, the height of the window is reduced by a factor of  $\frac{2}{3}$ . This prevents the contribution of the black bars above and below a 16 : 9 scene to the measurements.

## I<sup>2</sup>C-bus

The I<sup>2</sup>C-bus is always in standby mode and responds on a properly addressed command. Bit PDD (Power-Down Detected) in the status register is set each time an interruption of the power supply occurs and is reset only by reading the status register. A 3-bit identification code can also be read from the status register, which code can be used to automatically configure the application by software.

The input control registers can be written sequentially by the I<sup>2</sup>C-bus by the embedded automatic subaddress increment feature or by addressing them directly. The output control functions cannot be addressed separately. Reading out the output control functions always starts at subaddress 00H and all subsequent words are read out by the automatic subaddress increment procedure.

The bits in the I<sup>2</sup>C-bus are preset to logic 0 at power-on except for bits AMS and VG5: therefore the TDA9178 is in 1.0 V luminance signal range and the variable gamma is set to 20H (gamma correction 0%).

## I<sup>2</sup>C-BUS SPECIFICATION

The slave address of the IC is given in Table "Slave address". If pin ADR of the TDA9178 is connected to ground, the I<sup>2</sup>C-bus address is 40H; if pin ADR is connected to pin DEC<sub>DIG</sub>, the I<sup>2</sup>C-bus address is E0H. The circuit operates on clock frequencies up to 400 kHz.

### Slave address

A6	A5	A4	A3	A2	A1	A0	R/W
ADR	1	ADR	0	0	0	0	X

Auto-increment mode is available for subaddresses.

# YUV one chip picture improvement based on luminance vector-, colour vector- and spectral processor

TDA9178

## Control functions

FUNCTIONS	TYPE	SUBADDRESS	DATA BYTE							
			D7	D6	D5	D4	D3	D2	D1	D0
<b>Inputs</b>										
Control 1	REG	00	DEM	VDC	WLB	FHS	CFS	LDH	0	AMS
Control 2		01	0	0	OSP	WPO	0	CD2	CD1	CD0
Control 3		02	SGR	WGR	GGR	DGR	SSK	WSK	ASK	DSK
Control 4		03	0	0	BON	CTI	CDS	SBL	GBL	DBL
Adaptive black stretch	DAC	04	0	0	BT5	BT4	BT3	BT2	BT1	BT0
Non-linearity amplifier		05	0	0	NL5	NL4	NL3	NL2	NL1	NL0
Variable gamma		06	0	0	VG5	VG4	VG3	VG2	VG1	VG0
Peaking		07	0	0	PK5	PK4	PK3	PK2	PK1	PK0
Steepness		08	0	0	SP5	SP4	SP3	SP2	SP1	SP0
Coring		09	0	0	CR5	CR4	CR3	CR2	CR1	CR0
Line width		0A	0	0	LW5	LW4	LW3	LW2	LW1	LW0
<b>Outputs</b>										
Status	REG	00	X	X	X	CF	ID2	ID1	ID0	PDD
Noise detection		01	FM	DV	ND5	ND4	ND3	ND2	ND1	ND0
ADEXT1 (output)		02	X	DV	AD5	AD4	AD3	AD2	AD1	AD0
ADEXT2 (output)		03	X	DV	AD5	AD4	AD3	AD2	AD1	AD0
ADEXT3 (output)		04	X	DV	AD5	AD4	AD3	AD2	AD1	AD0

# YUV one chip picture improvement based on luminance vector-, colour vector- and spectral processor

TDA9178

## Input signals

**Table 1** Amplitude mode selection

AMS	FUNCTION
0	0.315 V luminance (black to white) at YIN
1	1.0 V luminance (black to white) at YIN

**Table 2** Luminance determined histogram

LDH	FUNCTION
0	histogram segments fixed
1	histogram segments determined by peak white

**Table 3** Contour filter selection

CFS	FUNCTION
0	peaking frequency is 2 MHz at $1f_H$ or 4 MHz at $2f_H$
1	peaking frequency is 3 MHz at $1f_H$ or 6 MHz at $2f_H$

**Table 4** Line frequency selection

FHS	FUNCTION
0	$1f_H$
1	$2f_H$

**Table 5** Window letterbox format

WLB	FUNCTION
0	normal internal window format
1	'Letterbox' internal window format

**Table 6** Video dependent coring on/off

VDC	FUNCTION
0	video dependent coring off
1	video dependent coring on

**Table 7** Demonstration mode on/off

DEM	FUNCTION
0	DEMO off
1	DEMO on: auto-toggle selected features on/off (cycle is 10 s at $1f_H$ or 5 s at $2f_H$ )

**Table 8** Chrominance delay

CD2	CD1	CD0	FUNCTION
0	0	0	40 ns at $1f_H$ or 20 ns at $2f_H$
1	1	1	-32 ns at $1f_H$ or +16 ns at $2f_H$

**Table 9** Overrule smart peaking

OSP	FUNCTION
0	smart peaking (maximum peaking reduced if Coxing)
1	overrule smart peaking

**Table 10** White-point stretch on/off

WPO	FUNCTION
0	white-point stretch on
1	white-point stretch off

**Table 11** Dynamic skin tone on/off

DSK	FUNCTION
0	skin tone off
1	skin tone on

**Table 12** Dynamic skin tone angle

ASK	FUNCTION
0	angle correction $123^\circ$
1	angle correction $117^\circ$

**Table 13** Dynamic skin tone width

WSK	FUNCTION
0	default detection angle
1	60% increased detection angle

**Table 14** Dynamic skin tone size

SSK	FUNCTION
0	default area
1	40% increased area

**Table 15** Green enhancement on/off

DGR	FUNCTION
0	green enhancement off
1	green enhancement on

# YUV one chip picture improvement based on luminance vector-, colour vector- and spectral processor

TDA9178

**Table 16** Green enhancement gain

GGR	FUNCTION
0	default enhancement
1	60% increased gain

**Table 17** Green enhancement width

WGR	FUNCTION
0	default detection angle
1	60% increased detection angle

**Table 18** Green enhancement size

SGR	FUNCTION
0	default area
1	40% increased area

**Table 19** Blue stretch on/off

DBL	FUNCTION
0	blue stretch off
1	blue stretch on

**Table 20** Blue stretch gain

GBL	FUNCTION
0	default gain
1	60% increased gain

**Table 21** Blue stretch size

SBL	FUNCTION
0	default area
1	40% increased area

**Table 22** Colour dependent sharpness on/off

CDS	FUNCTION
0	colour dependent sharpness off
1	colour dependent sharpness on

**Table 23** Colour transient improvement on/off

CTI	FUNCTION
0	colour transient improvement off
1	colour transient improvement on

**Table 24** Black offset compensation on/off

BON	FUNCTION
0	black offset compensation off
1	black offset compensation on

**Table 25** Adaptive black stretch

BT5	BT4	BT3	BT2	BT1	BT0	FUNCTION
0	0	0	0	0	0	0%
1	1	1	1	1	1	100%

**Table 26** Non-linearity amplifier

NL5	NL4	NL3	NL2	NL1	NL0	FUNCTION
0	0	0	0	0	0	0%
1	1	1	1	1	1	100%

**Table 27** Variable gamma

VG5	VG4	VG3	VG2	VG1	VG0	FUNCTION
0	0	0	0	0	0	-100%
1	1	1	1	1	1	100%

**Table 28** Peaking amplitude

PK5	PK4	PK3	PK2	PK1	PK0	FUNCTION
0	0	0	0	0	0	0%
1	1	1	1	1	1	100%

**Table 29** Steepness correction

SP5	SP4	SP3	SP2	SP1	SP0	FUNCTION
0	0	0	0	0	0	0%
1	1	1	1	1	1	100%

**Table 30** Coring level

CR5	CR4	CR3	CR2	CR1	CR0	FUNCTION
0	0	0	0	0	0	0%
1	1	1	1	1	1	30%

# YUV one chip picture improvement based on luminance vector-, colour vector- and spectral processor

TDA9178

**Table 31** Line width correction

LW5	LW4	LW3	LW2	LW1	LW0	FUNCTION
0	0	0	0	0	0	33% duty factor at 2 MHz sine wave/1f <sub>H</sub>
1	1	1	1	1	1	67% duty factor at 2 MHz sine wave/1f <sub>H</sub>

**Output signals****Table 32** Power-down detection

PDD	FUNCTION
0	no power-down detected since last read
1	power-down detected

**Table 33** Identification code

ID2	ID1	ID0	FUNCTION
0	1	0	TDA9178/N1

**Table 34** Cue flash

CF	FUNCTION
0	no cue flash since last read
1	cue flash detected

**Table 35** Noise detector

ND5	ND4	ND3	ND2	ND1	ND0	FUNCTION
0	0	0	0	0	0	-45 dB
1	1	1	1	1	1	-20 dB

**Table 36** ADEXT1, ADEXT2 and ADEXT3

AD5	AD4	AD3	AD2	AD1	AD0	FUNCTION
0	0	0	0	0	0	external voltage = 0 V
1	1	1	1	1	1	external voltage = 2 V

**Table 37** Data valid bit of noise detector/ADEXT1, 2 and 3 registers

DV	FUNCTION
0	data not valid because of possible register access collision
1	data is valid

**Table 38** Feature mode detector

FM	FUNCTION
0	normal video signal detected
1	feature mode detected (noise detector is not reliable)

**LIMITING VALUES**

In accordance with the Absolute Maximum Rating System (IEC 134); all voltages referenced to ground.

SYMBOL	PARAMETER	MIN.	MAX.	UNIT
V <sub>CC</sub>	supply voltage	-0.5	+8.8	V
V <sub>n</sub>	voltage on any pin	-0.5	V <sub>CC</sub> + 0.5	V
T <sub>stg</sub>	storage temperature	-55	+150	°C
T <sub>amb</sub>	operating ambient temperature	-10	+70	°C
T <sub>j</sub>	operating junction temperature	-	150	°C

**HANDLING**

All pins are protected against ESD by means of internal clamping diodes. The protection circuit meets the following specification:

Human body model: C = 100 pF; R = 1.5 kΩ; all pins >3000 V

Machine model: C = 200 pF; R = 0 Ω; all pins >200 V.

At an ambient temperature of 90 °C, all pins meet the following specification:

I<sub>trigger</sub> > 100 mA or V<sub>pin</sub> > 1.5V<sub>CC(max)</sub>

I<sub>trigger</sub> < -100 mA or V<sub>pin</sub> < -0.5V<sub>CC(max)</sub>

# YUV one chip picture improvement based on luminance vector-, colour vector- and spectral processor

TDA9178

## THERMAL CHARACTERISTICS

SYMBOL	PARAMETER	CONDITIONS	VALUE	UNIT
$R_{th(j-a)}$	thermal resistance from junction to ambient	in free air		
	TDA9178 (SDIP24)		56	K/W
	TDA9178T (SO24)		65	K/W

## QUALITY SPECIFICATION

In accordance with "SNW-FQ-611 part E".

## CHARACTERISTICS

$V_{CC} = 8\text{ V}$ ;  $T_{amb} = 25\text{ °C}$ ; unless otherwise specified.

SYMBOL	PARAMETER	CONDITIONS	MIN.	TYP.	MAX.	UNIT
<b>Supply</b>						
SUPPLY VOLTAGE (PIN $V_{CC}$ )						
$V_{CC}$	supply voltage		7.2	8.0	8.8	V
$I_{CC}$	supply current	1f <sub>H</sub> mode	–	100	–	mA
		2f <sub>H</sub> mode	–	105	–	mA
DIGITAL SUPPLY DECOUPLING (PIN $DEC_{DIG}$ )						
$V_{DECDIG}$	decoupling voltage		–	5	–	V
$I_{DECDIG}$	decoupling load current		–	–	1	mA
<b>Input and output selection</b>						
LUMINANCE INPUT (PIN $Y_{IN}$ )						
$V_{i(Y)}$	input voltage (excluding sync)	AMS = 0	–	0.315	0.45	V
		AMS = 1	–	1.0	1.41	V
$I_{i(bias)(Y)}$	input bias current	no clamp	–	–	0.1	μA
LUMINANCE OUTPUT (PIN $Y_{OUT}$ )						
$V_{o(cl)}$	output voltage level during clamping	AMS = 1	–	2.7	–	V
		AMS = 0	–	0.8	–	V
$G_{Y(i-o)}$	luminance gain input to output	transparent at AMS = 1; at 1 V (p-p)	0.93	1.04	1.15	
		transparent at AMS = 0; at 0.3 V (p-p)	0.96	1.07	1.18	
$S/N(Y)$	signal-to-noise ratio of luminance output	transparent	52	–	–	dB
$B_Y$	luminance bandwidth	1f <sub>H</sub> mode (–1 dB); transparent	5	–	–	MHz
		2f <sub>H</sub> mode (–1 dB); transparent	6	–	–	MHz
$E_{bl}$	black level error	transparent	–1.0	0	+1.0	%

# YUV one chip picture improvement based on luminance vector-, colour vector- and spectral processor

TDA9178

SYMBOL	PARAMETER	CONDITIONS	MIN.	TYP.	MAX.	UNIT
$R_o$	output resistance		–	–	150	$\Omega$
$I_{o(bias)}$	output bias current		1.3	–	–	mA
$C_L$	load capacitance		–	–	15	pF
COLOUR DIFFERENCE INPUTS U AND V (PINS UIN AND VIN)						
$V_{i(U)(p-p)}$	input voltage U (peak-to-peak value)		–	1.33	1.9	V
$V_{i(V)(p-p)}$	input voltage V (peak-to-peak value)		–	1.05	1.9	V
$I_{i(bias)}$	input bias current	no clamp	–	–	0.1	$\mu$ A
COLOUR DIFFERENCE OUTPUTS U AND V (PINS UOUT AND VOUT)						
$V_{o(cl)}$	output voltage level during clamping		–	2.7	–	V
$G_{UV(i-o)}$	gain inputs to output	transparent	0.90	1.00	1.10	
$E_{offset}$	offset error	transparent	–1	0	+1	%
$\Delta G_{track}$	UV gain tracking error	transparent	–	–	5	%
$B_{UV}$	bandwidth	1f <sub>H</sub> mode; transparent (–3 dB)	2.5	–	–	MHz
		2f <sub>H</sub> mode; transparent (–3 dB)	5	–	–	MHz
$R_o$	output resistance		–	–	150	$\Omega$
$I_{o(bias)}$	output bias current		1.3	–	–	mA
$C_L$	load capacitance		–	–	15	pF
<b>Luminance vector processing</b>						
BLACK STRETCH						
$BLOS_{cor(i)}$	input black offset correction		8	10	12	%
HISTOGRAM						
<i>White-point stretch</i>						
$G_{WP(max)}$	maximum luminance gain for white stretch	maximum non-linearity setting gain	–	1.1	–	
<i>Non-linear amplifier</i>						
$G_{nla(min)}$	minimum segment gain	maximum non-linearity setting gain	–	0.4	–	
$G_{nla(max)}$	maximum segment gain	maximum non-linearity setting gain	–	2.0	–	
$G_{nla}$	non-linear control curve	63 steps	–	0 to 100	–	%
VARIABLE GAMMA						
$G_{g(var)(min)L}$	minimum variable gamma setting		–	0.5	–	
$G_{g(var)(max)}$	maximum variable gamma setting		–	1.5	–	
$G_{nla}$	non-linear control curve	63 steps	–	0 to 100	–	%



# YUV one chip picture improvement based on luminance vector-, colour vector- and spectral processor

TDA9178

SYMBOL	PARAMETER	CONDITIONS	MIN.	TYP.	MAX.	UNIT
<b>Colour vector processing</b>						
SKIN TONE; note 1 and Fig.4						
$\varphi_{cor}$	correction angle	ASK = 0; DSK = 1	–	123	–	deg
		ASK = 1; DSK = 1	–	117	–	deg
$\varphi_{ap}$	correction range (or aperture angle)	DSK = 1; SSK = 1; WSK = 0	–	45	–	deg
GREEN ENHANCEMENT; note 1 and Fig.5						
$\varphi_{cor}$	correction angle	DGR = 1	–	208	–	deg
$\varphi_{ap}$	correction range (or aperture angle)	DGR = 1; SGR = 0; WGR = 0	–	45	–	deg
BLUE STRETCH; note 2 and Fig.6						
$\varphi_{(str)}$	stretch angle	DBL = 1	–	330	–	deg
<b>Spectral processing</b>						
GENERAL						
$Q_{max}$	maximum contour amplitude at centre frequency	note 3	–	12	–	dB
<i>Contour filter low frequency peaking</i>						
$f_{pc(l)}$	peaking centre frequency	$1f_H$ mode; CFS = 0	–	2.0	–	MHz
		$2f_H$ mode; CFS = 0	–	4.0	–	MHz
<i>Contour filter high frequency peaking</i>						
$f_{pc(h)}$	peaking centre frequency	$1f_H$ mode; CFS = 1	–	3.0	–	MHz
		$2f_H$ mode; CFS = 1	–	6.0	–	MHz
<i>Step detector</i>						
$f_{dc}$	detection centre frequency	$1f_H$ mode	–	1.18	–	MHz
		$2f_H$ mode	–	2.36	–	MHz
PEAKING						
$G_{PK}$	peaking control curve	63 steps	–	0 to 100	–	%
CORING						
$G_{CR}$	coring control curve	63 steps	–	0 to 45	–	%
LUMINANCE TRANSIENT IMPROVEMENT						
$t_{r(min)}$	minimum rise time 10% to 90%	note 4	–	30	–	ns
$G_{SP}$	steepness control curve	63 steps	–	0 to 100	–	%
<i>Line width control</i>						
$t_{sd(max)}$	maximum step displacement	$1f_H$ mode	–	140	–	ns
		$2f_H$ mode	–	70	–	ns
$G_{LW}$	line width control curve (duty factor)	63 steps at 1 MHz sine wave at $1f_H$	–	33 to 67	–	%

# YUV one chip picture improvement based on luminance vector-, colour vector- and spectral processor

TDA9178

SYMBOL	PARAMETER	CONDITIONS	MIN.	TYP.	MAX.	UNIT
<b>COLOUR TRANSIENT IMPROVEMENT</b>						
$t_{r(\min)}$	minimum rise time 10% to 90%	note 5	–	50	–	ns
<b>COLOUR DEPENDENT SHARPNESS</b>						
$f_{pc}$	peaking centre frequency	$1f_H$ mode	–	2.0	–	MHz
		$2f_H$ mode	–	4.0	–	MHz
$Q_{\max}$	maximum contour amplitude at centre frequency	note 3	–	6	–	dB
<b>SCAVEM</b>						
<b>SCAVEM OUTPUT (PIN SOUT)</b>						
$V_{o(\text{cl})}$	output voltage level during clamping		–	2.2	–	V
$G_Y$	gain luminance input to SCAVEM output		0.93	1.04	1.15	
$B_Y$	bandwidth	$1f_H$ mode (–1 dB)	5	–	–	MHz
		$2f_H$ mode (–1 dB)	6.0	–	–	MHz
$R_o$	output resistance		–	–	150	$\Omega$
$I_{o(\text{bias})}$	output bias current		0.8	–	–	mA
$C_L$	load capacitance		–	–	15	pF
$t_{d(\text{SOUT-YOUT})}$	delay w.r.t. YOUT		–	–20	–	ns
<b>Successive approximation ADC</b>						
<b>ADC INPUTS (PINS ADEXT1, ADEXT2 AND ADEXT3)</b>						
$V_{FS}$	full-scale input voltage range	with respect to ground	–	2.0	–	V
$I_{i(\text{bias})}$	input bias current		–	–	0.1	$\mu\text{A}$
RES	data path resolution		–	6	–	bit
DLE	differential linearity error		–	–	1	LSB
ILE	integral linearity error		–	–	1	LSB
$f_{\text{con}}$	conversion frequency	ADEXT1	–	$1f_V$	–	Hz
		ADEXT2; ADEXT3	–	$0.5f_V$	–	Hz
$Q_{\text{adt}}$	conversion time (video lines)	each channel	–	8	–	lines
<b>Timing</b>						
<b>SANDCASTLE INPUT (PIN SC)</b>						
$I_{i(\text{bias})}$	input bias current		–	–	1	$\mu\text{A}$
$V_{sc(\text{bn})}$	detection level for blank	no clamping	0.9	1.15	1.40	V
$V_{sc(\text{bc})}$	detection level for clamp		–	$0.9V_{\text{top}}$	–	V
$t_{W(\text{bk})}$	burst key pulse width	$1f_H$ mode	1.8	–	–	$\mu\text{s}$
		$2f_H$ mode	0.9	–	–	$\mu\text{s}$
$t_V$	vertical retrace time		6	–	–	lines
$V_{\text{bk}(\text{var})}(\text{p-p})$	ripple on sandcastle burst key level (peak-to-peak value)		–	–	$0.04V_{\text{top}}$	V

# YUV one chip picture improvement based on luminance vector-, colour vector- and spectral processor

TDA9178

SYMBOL	PARAMETER	CONDITIONS	MIN.	TYP.	MAX.	UNIT
<b>Overall output group delay performance</b>						
$t_{d(YUV)}$	input to output delay of YUV signals	1f <sub>H</sub> mode; transparent	–	300	–	ns
		2f <sub>H</sub> mode; transparent	–	180	–	ns
$t_{dm(UV-Y)}$	adjustment delay U and V signals w.r.t. Y signal	1f <sub>H</sub> mode; transparent	–32	0	+40	ns
		2f <sub>H</sub> mode; transparent	–16	0	+20	ns
<b>Noise measurement</b>						
$R_{noise}$	range of noise detector	see Figure 18	–45	–	–20	dB
$t_{con}$	conversion time		–	32f <sub>V</sub>	–	s
<b>Cue flash</b>						
CUE FLASH OUTPUT (PIN CF); OPEN COLLECTOR						
$V_{o(max)}$	maximum output voltage	pull-up to external supply	–	–	5.5	V
$I_{sink(max)}$	maximum sink current		–	–	1	mA

**Notes**

1. The amount of correction depends on the parameters of the incoming YUV signals; therefore it is not possible to give exact figures for the correction angle. The aperture angle of the correction range of 45° (±22.5°) is just given as an indication and is valid for an input signal with a luminance signal amplitude of 75% and a colour saturation of 50%.
2. The amount of correction depends on the parameters of the incoming YUV signals; therefore it is not possible to give exact figures for the correction angle.
3. The contour signal cannot be measured separately from the luminance input signal. The contour signal is also processed by the smart noise controller. The frequency transfer in the peaking mode of the luminance signal can be derived from the frequency transfer of the selected contour signal, taking into account the summation of the contour signal and the luminance input signal. The frequency transfer is most easily measured by sine excitation with a relatively small signal amplitude of 10% of the selected dynamic range of the luminance input, to avoid interaction with the step detector.
4. Peaking set to minimum. Input signal is a sine wave with the nominal peak-to-peak amplitude corresponding to the selected input range.
5. Input signal is a 250 kHz block with a rise time of 260 ns and a nominal peak-to-peak amplitude corresponding to the selected input range.

# YUV one chip picture improvement based on luminance vector-, colour vector- and spectral processor

TDA9178

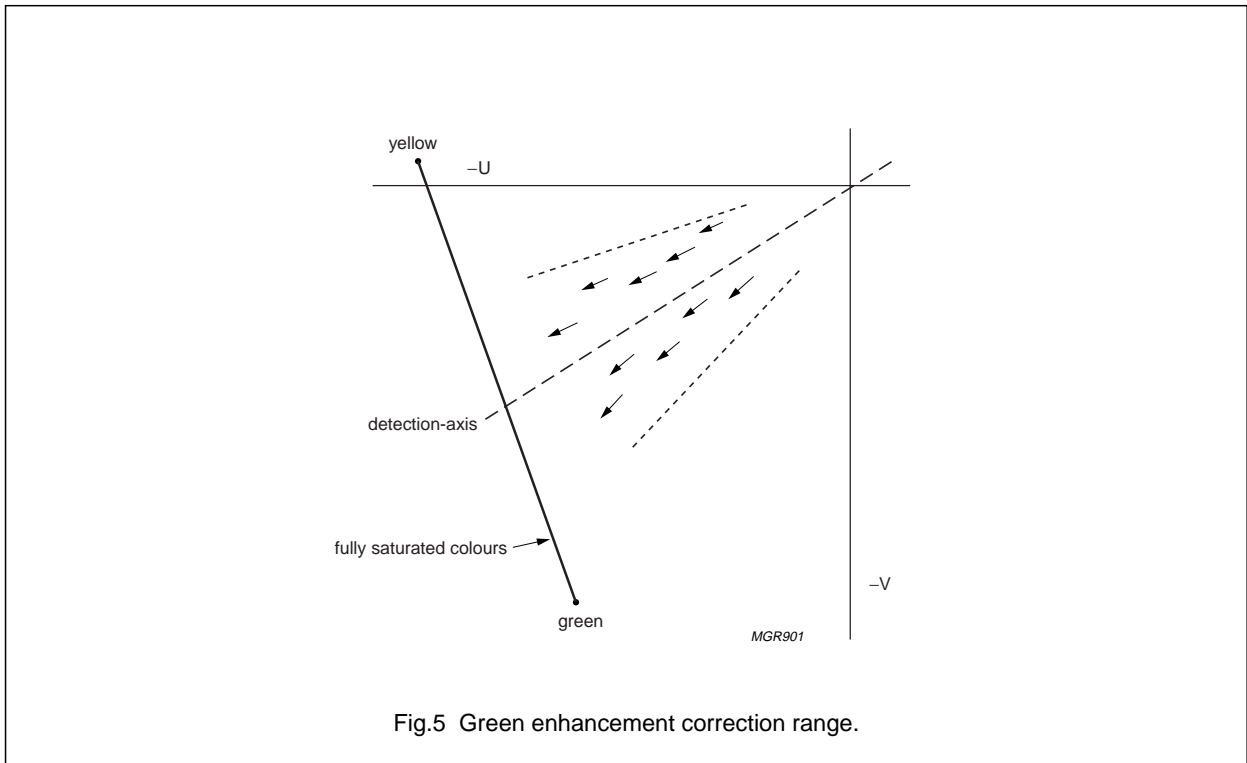
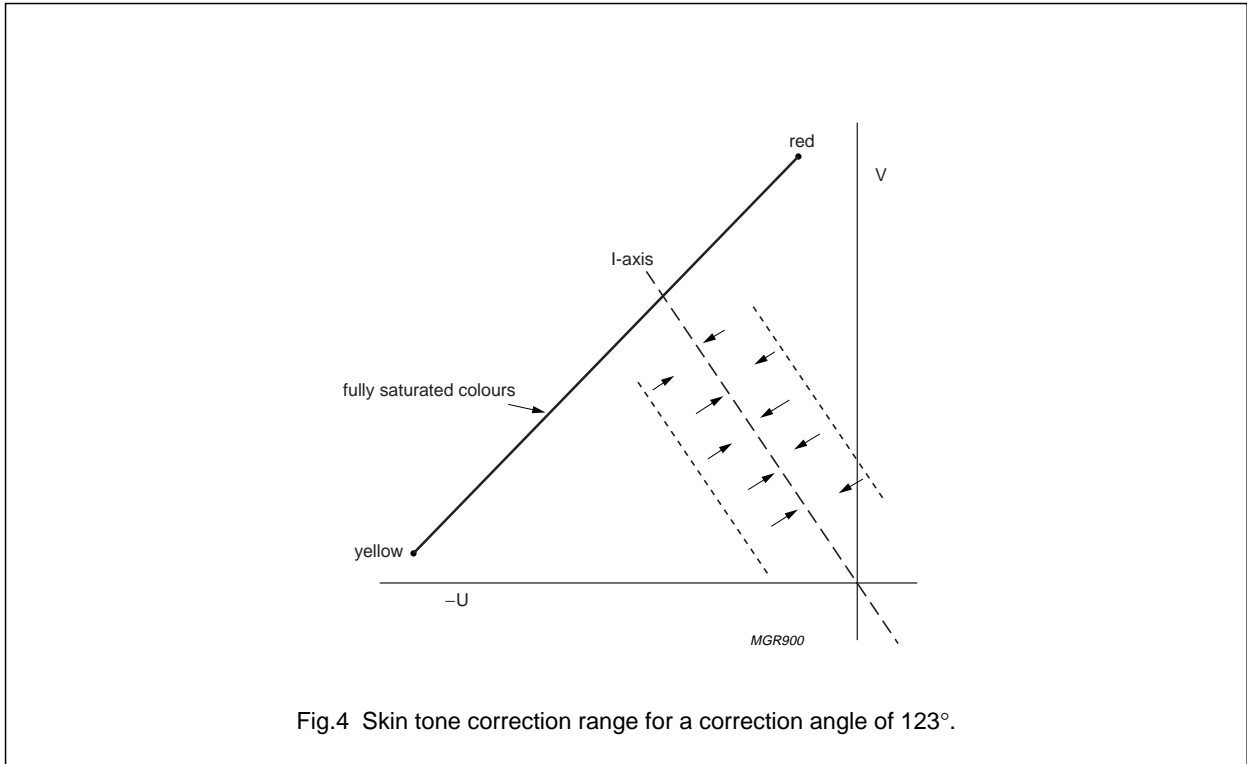

YUV one chip picture improvement based on luminance vector-, colour vector- and spectral processor

TDA9178

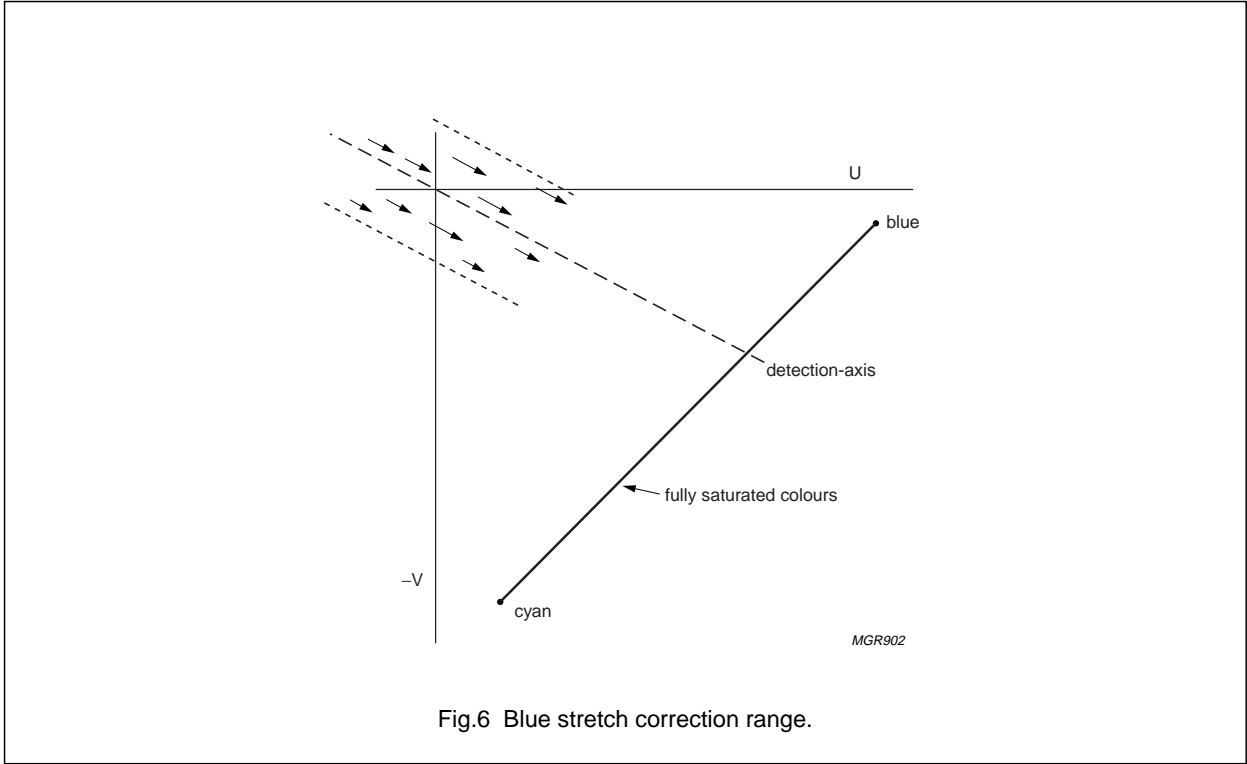

YUV one chip picture improvement based on luminance  
vector-, colour vector- and spectral processor

TDA9178

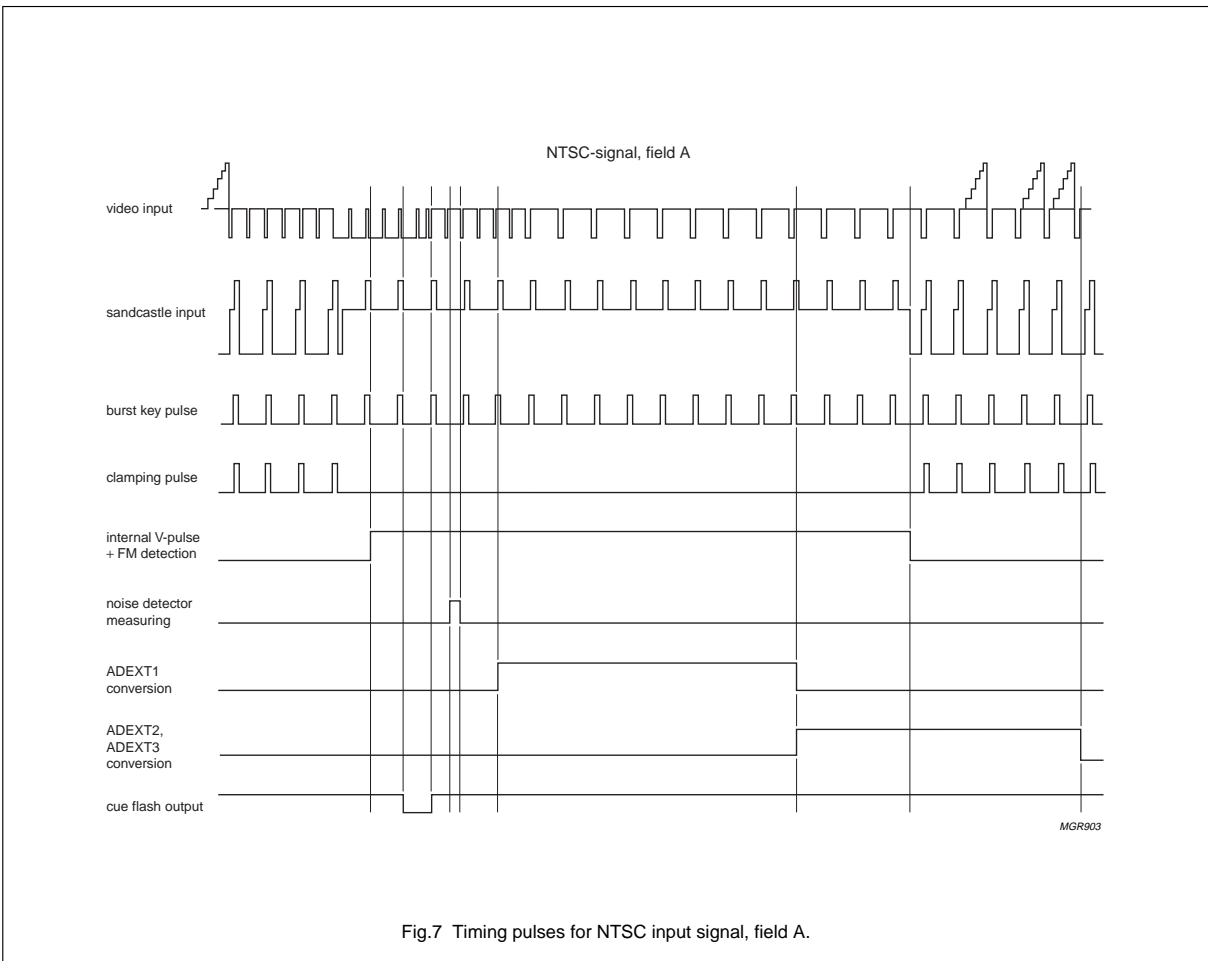

Fig.7 Timing pulses for NTSC input signal, field A.

YUV one chip picture improvement based on luminance  
vector-, colour vector- and spectral processor

TDA9178

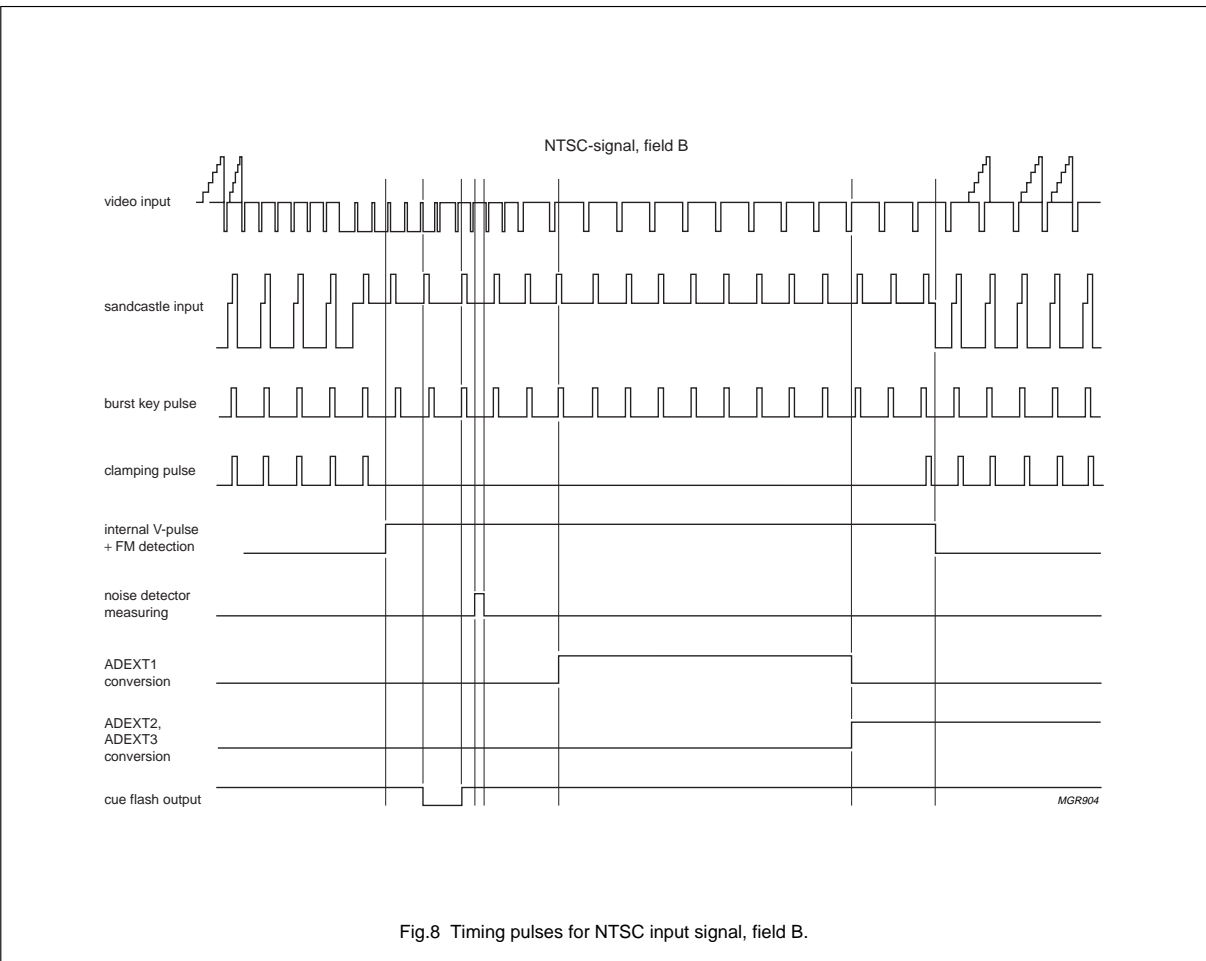

Fig.8 Timing pulses for NTSC input signal, field B.

YUV one chip picture improvement based on luminance  
vector-, colour vector- and spectral processor

TDA9178

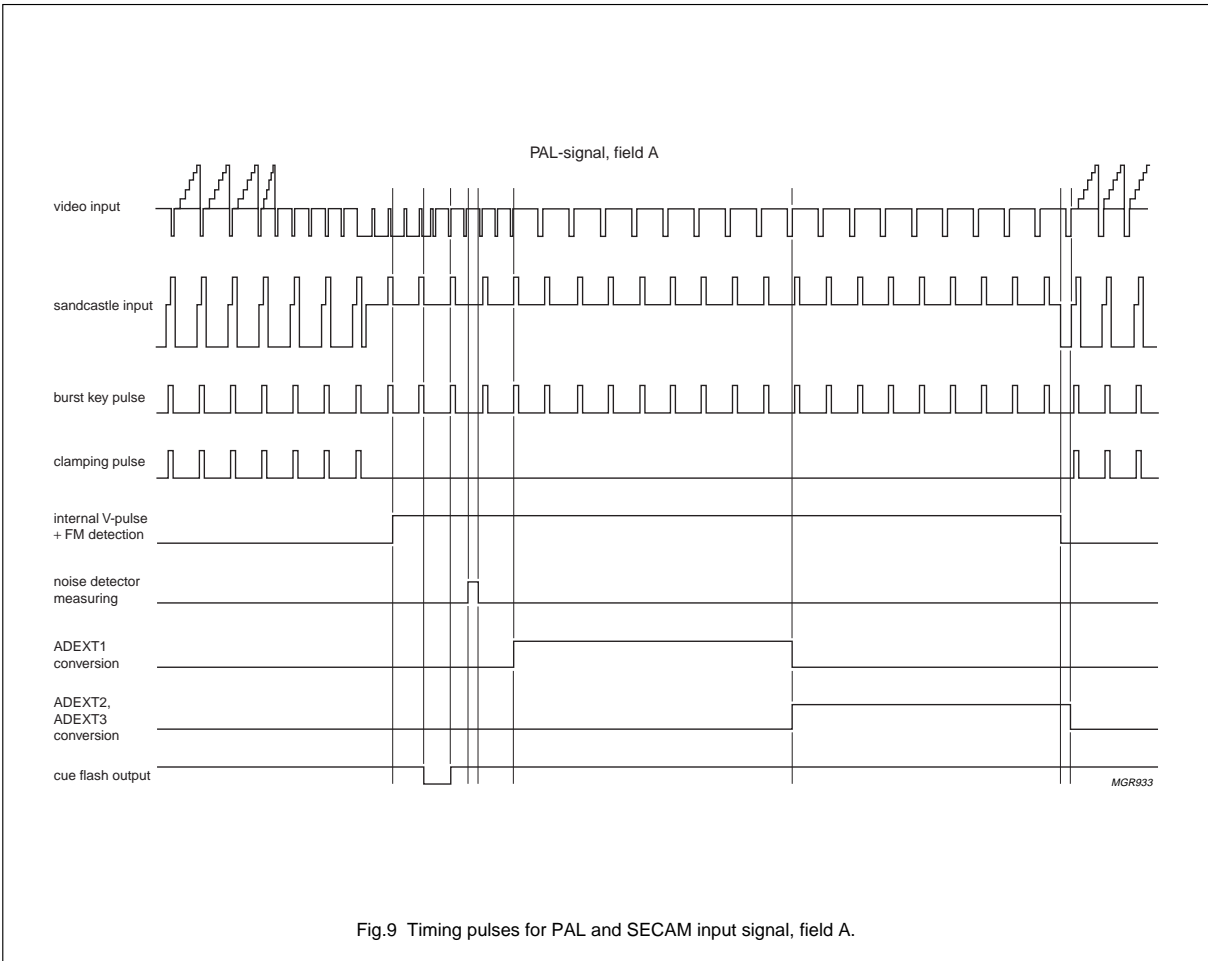

Fig.9 Timing pulses for PAL and SECAM input signal, field A.



YUV one chip picture improvement based on luminance vector-, colour vector- and spectral processor

TDA9178

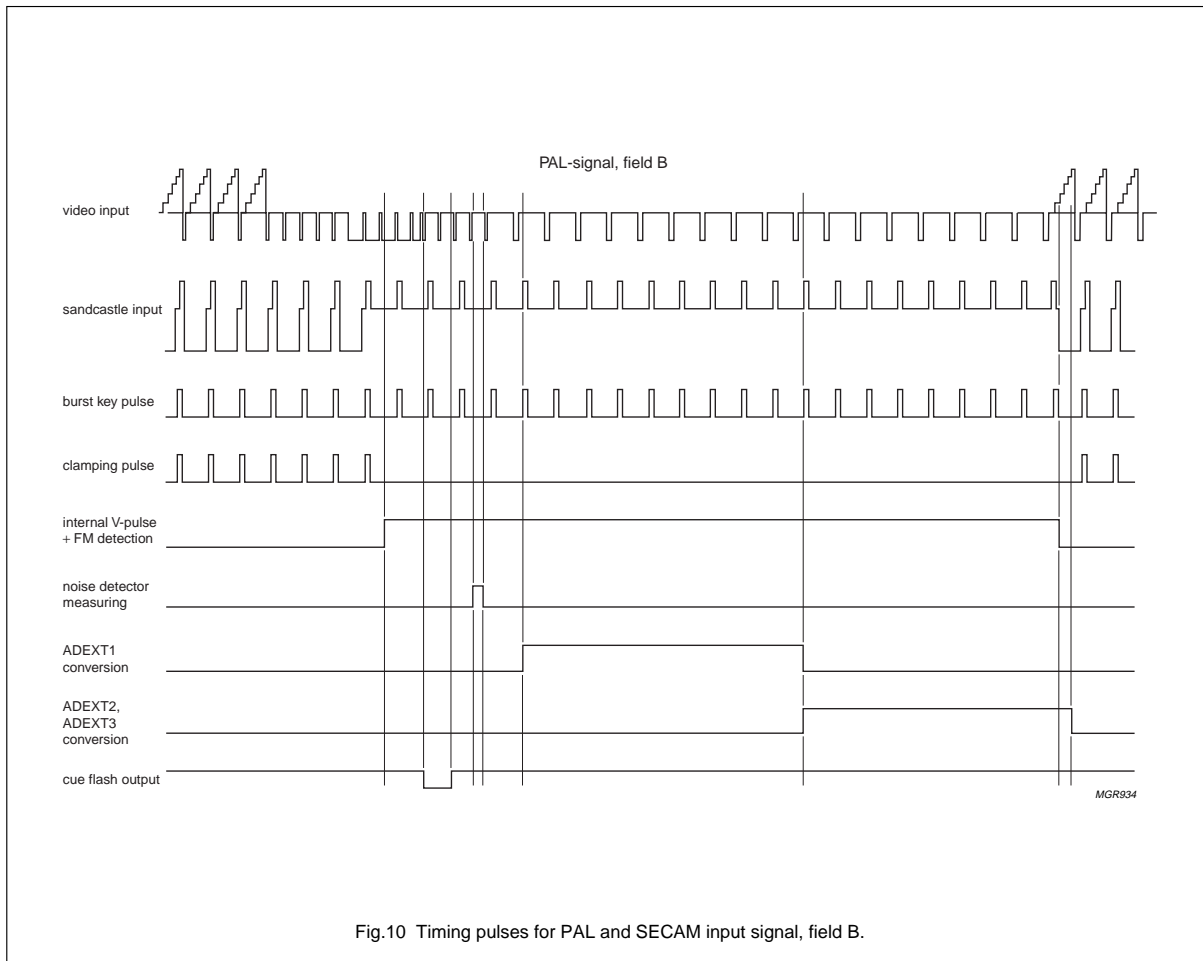

Fig.10 Timing pulses for PAL and SECAM input signal, field B.

YUV one chip picture improvement based on luminance vector-, colour vector- and spectral processor

TDA9178

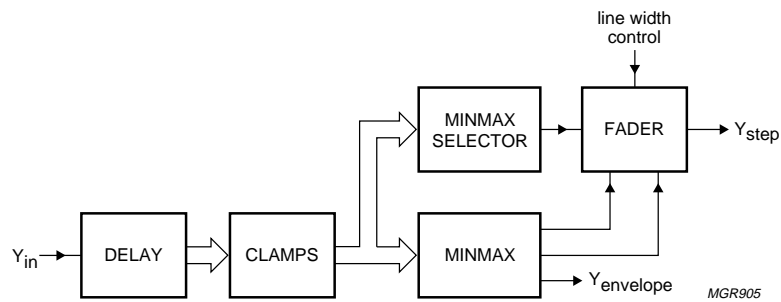
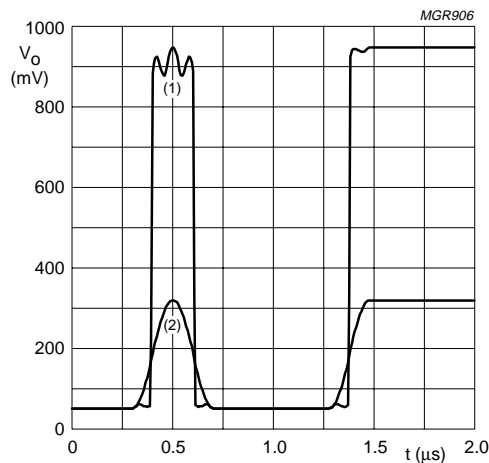

Fig.11 Block diagram of the step improvement processor.



- (1) 90% of nominal amplitude.
- (2) 30% of nominal amplitude.

Fig.12 Response signals for maximum step improvement, no peaking and nominal line width.

YUV one chip picture improvement based on luminance vector-, colour vector- and spectral processor

TDA9178

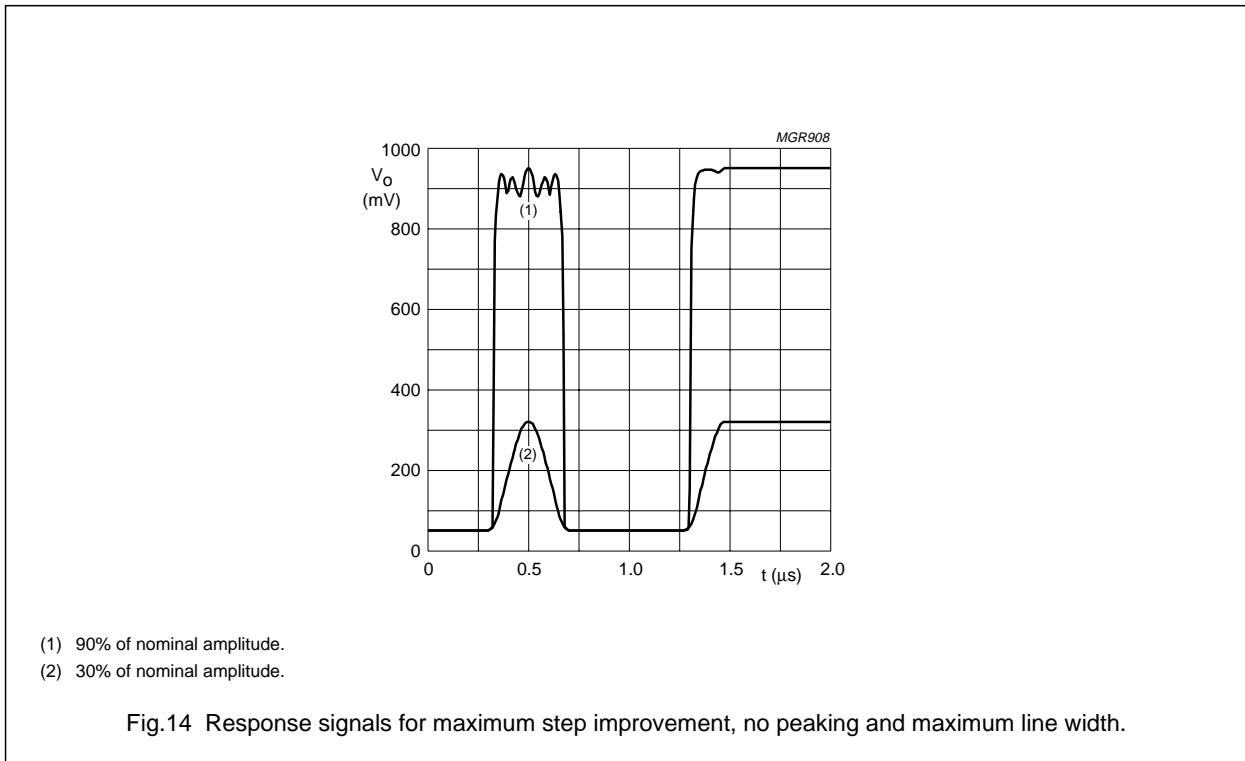
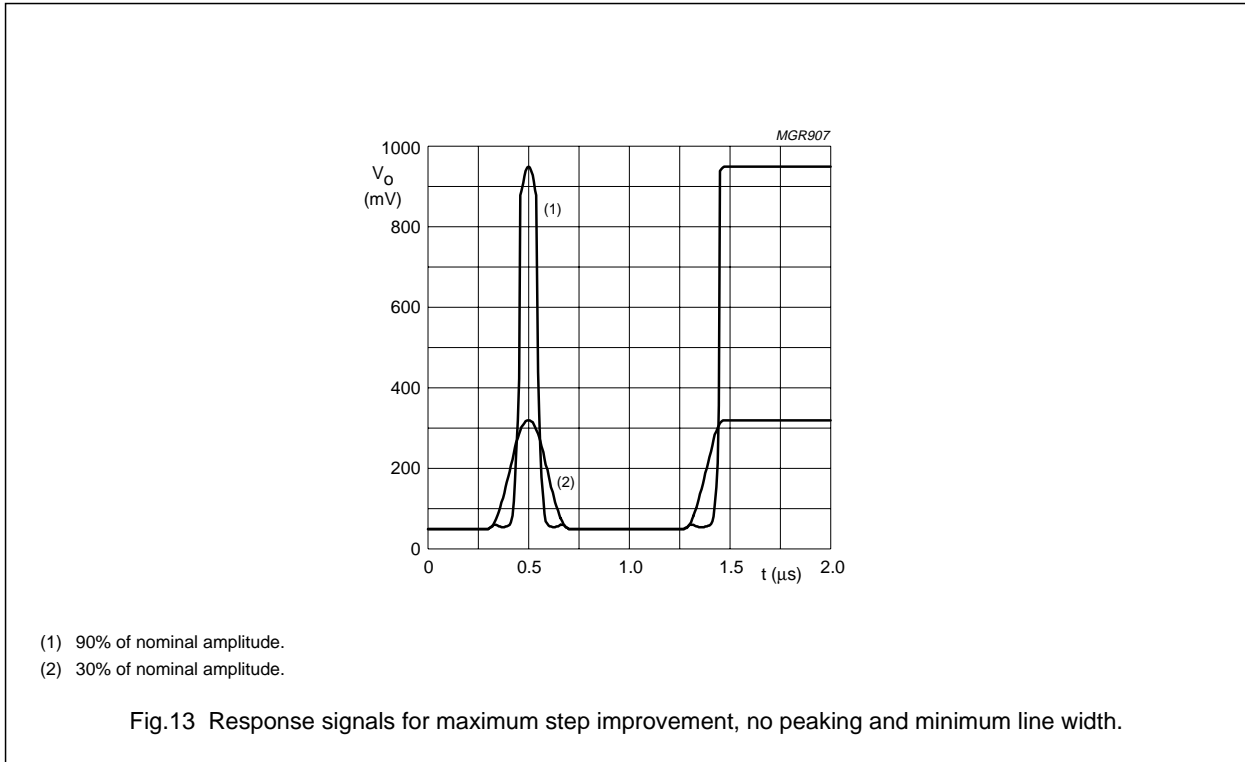

YUV one chip picture improvement based on luminance vector-, colour vector- and spectral processor

TDA9178

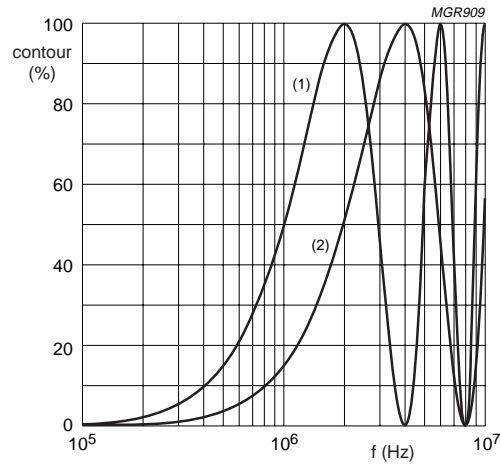

- (1)  $1f_H$  mode.
- (2)  $2f_H$  mode.

Fig.15 Frequency transfers of contour filter at  $f = 2.0$  MHz.

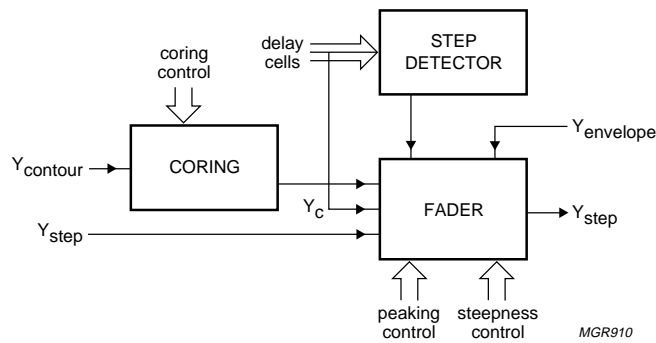

Fig.16 Block diagram of smart sharpness controller.

YUV one chip picture improvement based on luminance vector-, colour vector- and spectral processor

TDA9178

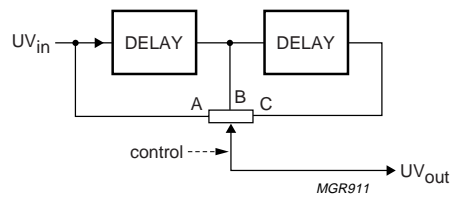

Fig.17 Block diagram of colour transient improvement.

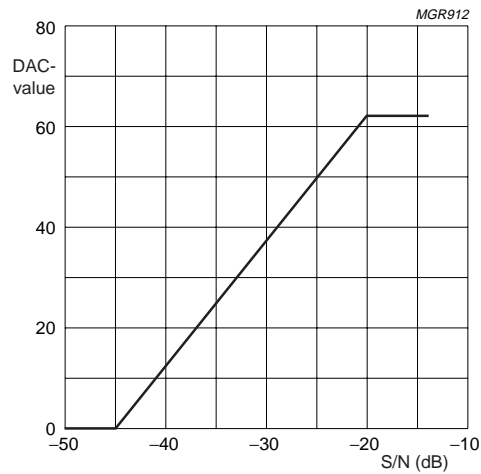

Fig.18 Typical noise measurement curve of input noise (dB) versus DAC-value.

# YUV one chip picture improvement based on luminance vector-, colour vector- and spectral processor

TDA9178

## TEST AND APPLICATION INFORMATION

The TDA9178 is especially designed for YUV applications. A typical application diagram is shown in Fig.19.

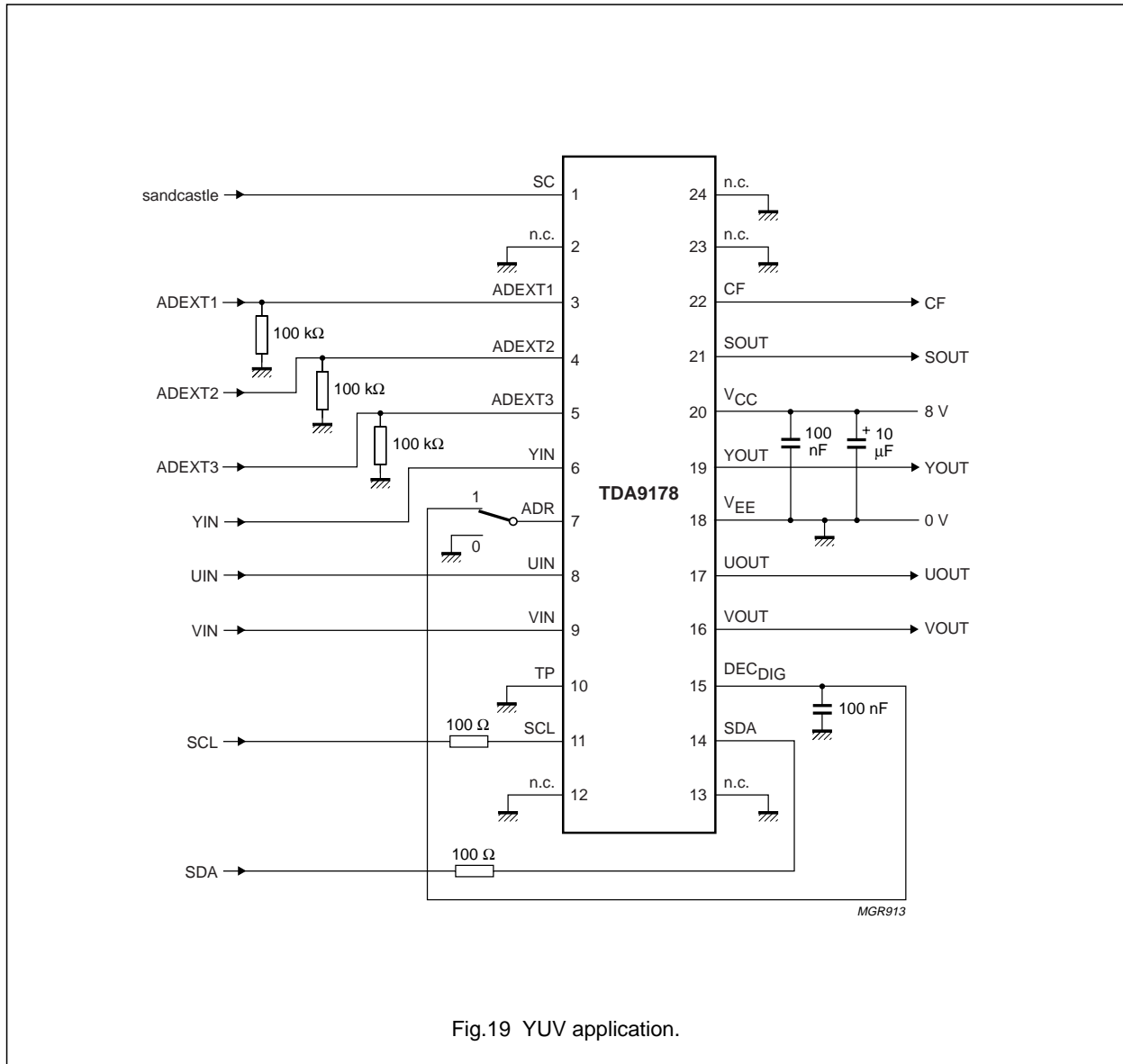

Fig.19 YUV application.

YUV one chip picture improvement based on luminance vector-, colour vector- and spectral processor

TDA9178

PACKAGE OUTLINES

SDIP24: plastic shrink dual in-line package; 24 leads (400 mil)

SOT234-1

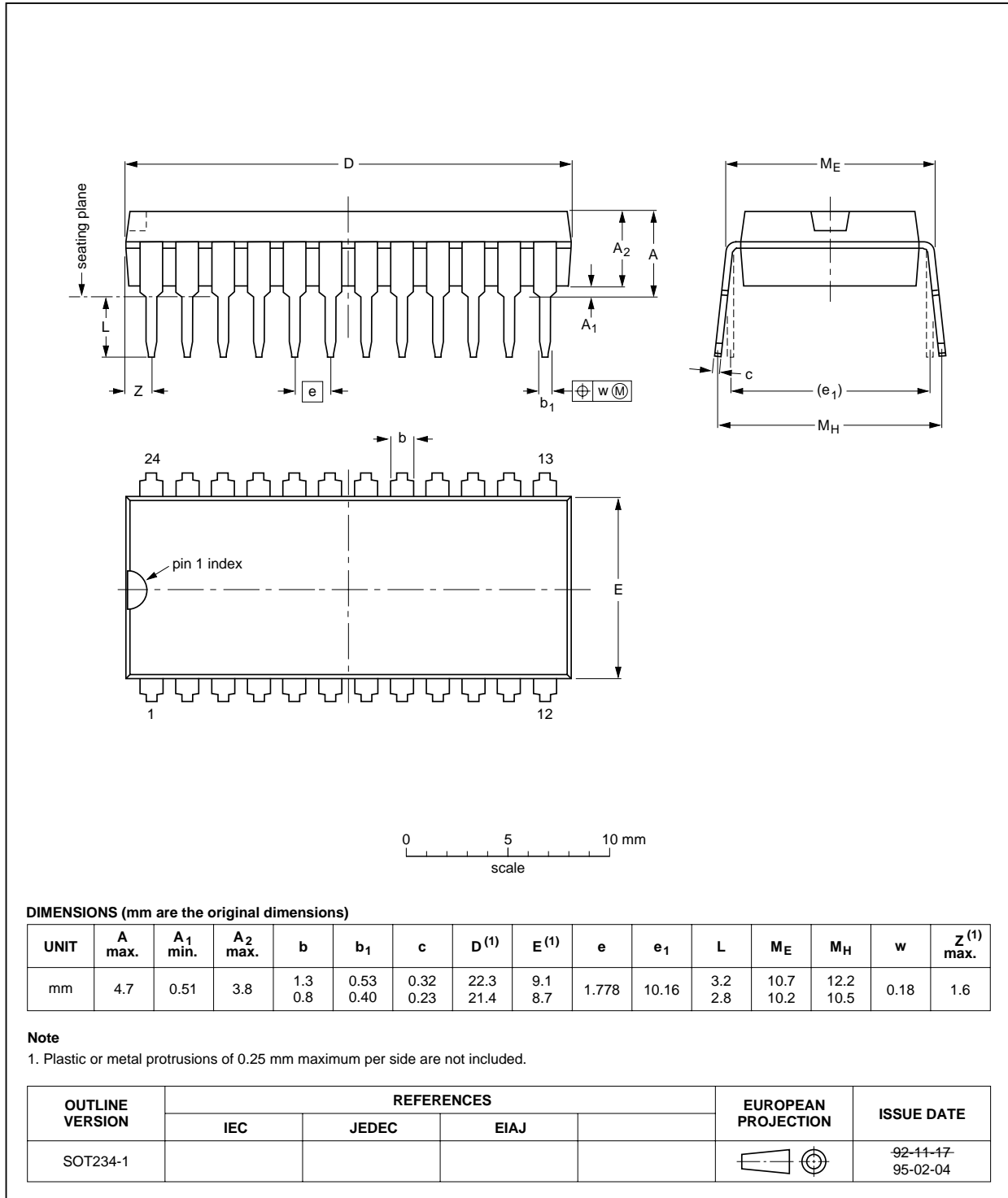

YUV one chip picture improvement based on luminance vector-, colour vector- and spectral processor

TDA9178

SO24: plastic small outline package; 24 leads; body width 7.5 mm

SOT137-1

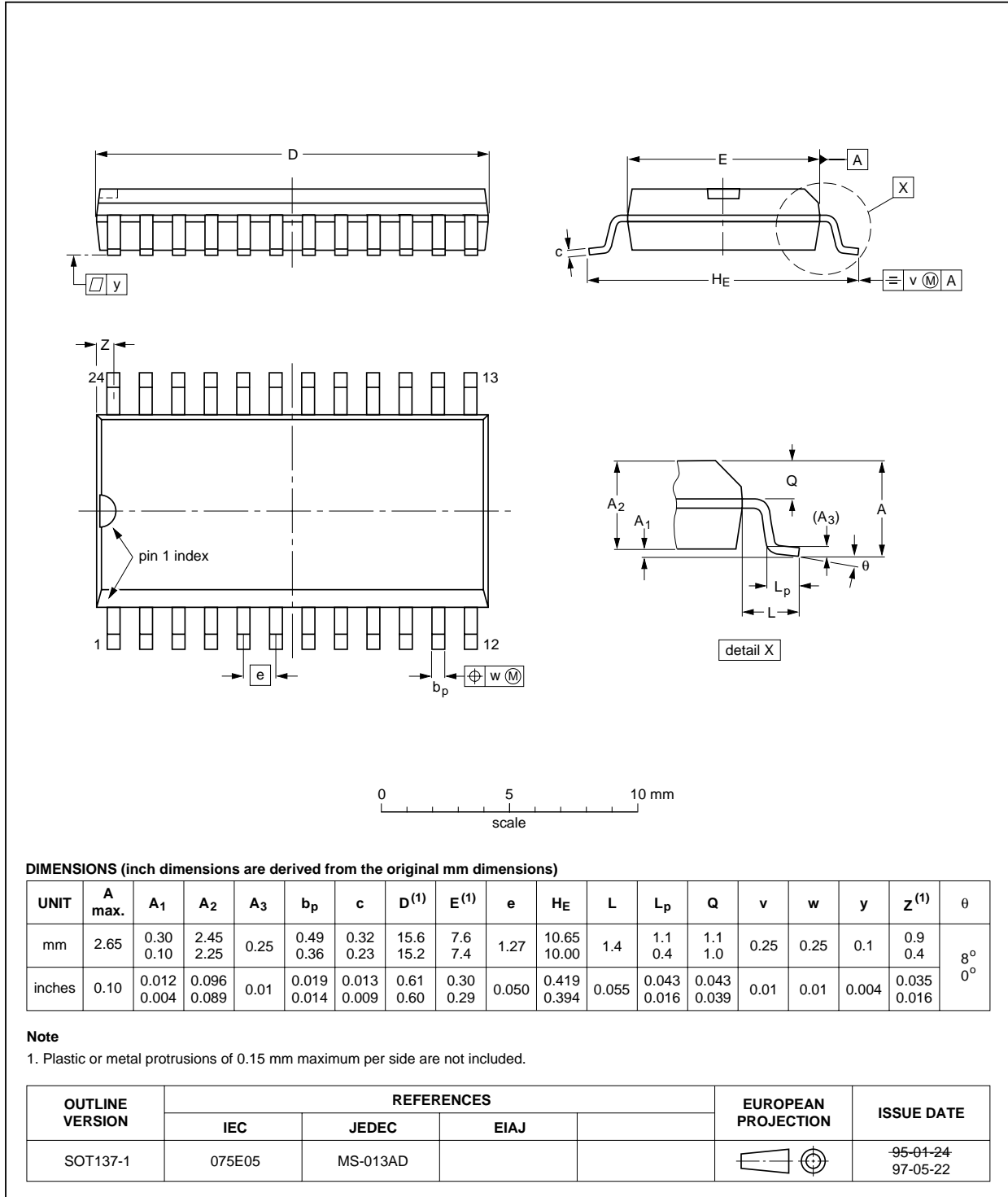



# YUV one chip picture improvement based on luminance vector-, colour vector- and spectral processor

TDA9178

## SOLDERING

### Introduction

This text gives a very brief insight to a complex technology. A more in-depth account of soldering ICs can be found in our "Data Handbook IC26; Integrated Circuit Packages" (document order number 9398 652 90011).

There is no soldering method that is ideal for all IC packages. Wave soldering is often preferred when through-hole and surface mount components are mixed on one printed-circuit board. However, wave soldering is not always suitable for surface mount ICs, or for printed-circuit boards with high population densities. In these situations reflow soldering is often used.

### Through-hole mount packages

#### SOLDERING BY DIPPING OR BY SOLDER WAVE

The maximum permissible temperature of the solder is 260 °C; solder at this temperature must not be in contact with the joints for more than 5 seconds. The total contact time of successive solder waves must not exceed 5 seconds.

The device may be mounted up to the seating plane, but the temperature of the plastic body must not exceed the specified maximum storage temperature ( $T_{stg(max)}$ ). If the printed-circuit board has been pre-heated, forced cooling may be necessary immediately after soldering to keep the temperature within the permissible limit.

#### MANUAL SOLDERING

Apply the soldering iron (24 V or less) to the lead(s) of the package, either below the seating plane or not more than 2 mm above it. If the temperature of the soldering iron bit is less than 300 °C it may remain in contact for up to 10 seconds. If the bit temperature is between 300 and 400 °C, contact may be up to 5 seconds.

### Surface mount packages

#### REFLOW SOLDERING

Reflow soldering requires solder paste (a suspension of fine solder particles, flux and binding agent) to be applied to the printed-circuit board by screen printing, stencilling or pressure-syringe dispensing before package placement.

Several methods exist for reflowing; for example, infrared/convection heating in a conveyor type oven. Throughput times (preheating, soldering and cooling) vary between 100 and 200 seconds depending on heating method.

Typical reflow peak temperatures range from 215 to 250 °C. The top-surface temperature of the packages should preferably be kept below 230 °C.

#### WAVE SOLDERING

Conventional single wave soldering is not recommended for surface mount devices (SMDs) or printed-circuit boards with a high component density, as solder bridging and non-wetting can present major problems.

To overcome these problems the double-wave soldering method was specifically developed.

If wave soldering is used the following conditions must be observed for optimal results:

- Use a double-wave soldering method comprising a turbulent wave with high upward pressure followed by a smooth laminar wave.
- For packages with leads on two sides and a pitch (e):
  - larger than or equal to 1.27 mm, the footprint longitudinal axis is **preferred** to be parallel to the transport direction of the printed-circuit board;
  - smaller than 1.27 mm, the footprint longitudinal axis **must** be parallel to the transport direction of the printed-circuit board.

The footprint must incorporate solder thieves at the downstream end.

- For packages with leads on four sides, the footprint must be placed at a 45° angle to the transport direction of the printed-circuit board. The footprint must incorporate solder thieves downstream and at the side corners.

During placement and before soldering, the package must be fixed with a droplet of adhesive. The adhesive can be applied by screen printing, pin transfer or syringe dispensing. The package can be soldered after the adhesive is cured.

Typical dwell time is 4 seconds at 250 °C.

A mildly-activated flux will eliminate the need for removal of corrosive residues in most applications.

#### MANUAL SOLDERING

Fix the component by first soldering two diagonally-opposite end leads. Use a low voltage (24 V or less) soldering iron applied to the flat part of the lead. Contact time must be limited to 10 seconds at up to 300 °C.

When using a dedicated tool, all other leads can be soldered in one operation within 2 to 5 seconds between 270 and 320 °C.

# YUV one chip picture improvement based on luminance vector-, colour vector- and spectral processor

TDA9178

## Suitability of IC packages for wave, reflow and dipping soldering methods

MOUNTING	PACKAGE	SOLDERING METHOD		
		WAVE	REFLOW <sup>(1)</sup>	DIPPING
Through-hole mount	DBS, DIP, HDIP, SDIP, SIL	suitable <sup>(2)</sup>	–	suitable
Surface mount	BGA, LFBGA, SQFP, TFBGA	not suitable	suitable	–
	HBCC, HLQFP, HSQFP, HSOP, HTQFP, HTSSOP, SMS	not suitable <sup>(3)</sup>	suitable	–
	PLCC <sup>(4)</sup> , SO, SOJ	suitable	suitable	–
	LQFP, QFP, TQFP	not recommended <sup>(4)(5)</sup>	suitable	–
	SSOP, TSSOP, VSO	not recommended <sup>(6)</sup>	suitable	–

### Notes

1. All surface mount (SMD) packages are moisture sensitive. Depending upon the moisture content, the maximum temperature (with respect to time) and body size of the package, there is a risk that internal or external package cracks may occur due to vaporization of the moisture in them (the so called popcorn effect). For details, refer to the Drypack information in the "Data Handbook IC26; Integrated Circuit Packages; Section: Packing Methods".
2. For SDIP packages, the longitudinal axis must be parallel to the transport direction of the printed-circuit board.
3. These packages are not suitable for wave soldering as a solder joint between the printed-circuit board and heatsink (at bottom version) can not be achieved, and as solder may stick to the heatsink (on top version).
4. If wave soldering is considered, then the package must be placed at a 45° angle to the solder wave direction. The package footprint must incorporate solder thieves downstream and at the side corners.
5. Wave soldering is only suitable for LQFP, QFP and TQFP packages with a pitch (e) equal to or larger than 0.8 mm; it is definitely not suitable for packages with a pitch (e) equal to or smaller than 0.65 mm.
6. Wave soldering is only suitable for SSOP and TSSOP packages with a pitch (e) equal to or larger than 0.65 mm; it is definitely not suitable for packages with a pitch (e) equal to or smaller than 0.5 mm.

# YUV one chip picture improvement based on luminance vector-, colour vector- and spectral processor

TDA9178

## DEFINITIONS

<b>Data sheet status</b>	
Objective specification	This data sheet contains target or goal specifications for product development.
Preliminary specification	This data sheet contains preliminary data; supplementary data may be published later.
Product specification	This data sheet contains final product specifications.
<b>Limiting values</b>	
Limiting values given are in accordance with the Absolute Maximum Rating System (IEC 134). Stress above one or more of the limiting values may cause permanent damage to the device. These are stress ratings only and operation of the device at these or at any other conditions above those given in the Characteristics sections of the specification is not implied. Exposure to limiting values for extended periods may affect device reliability.	
<b>Application information</b>	
Where application information is given, it is advisory and does not form part of the specification.	

## LIFE SUPPORT APPLICATIONS

These products are not designed for use in life support appliances, devices, or systems where malfunction of these products can reasonably be expected to result in personal injury. Philips customers using or selling these products for use in such applications do so at their own risk and agree to fully indemnify Philips for any damages resulting from such improper use or sale.

## PURCHASE OF PHILIPS I<sup>2</sup>C COMPONENTS



Purchase of Philips I<sup>2</sup>C components conveys a license under the Philips' I<sup>2</sup>C patent to use the components in the I<sup>2</sup>C system provided the system conforms to the I<sup>2</sup>C specification defined by Philips. This specification can be ordered using the code 9398 393 40011.

# Philips Semiconductors – a worldwide company

**Argentina:** see South America

**Australia:** 3 Figtree Drive, HOMEBUSH, NSW 2140,  
Tel. +61 2 9704 8141, Fax. +61 2 9704 8139

**Austria:** Computerstr. 6, A-1101 WIEN, P.O. Box 213,  
Tel. +43 1 60 101 1248, Fax. +43 1 60 101 1210

**Belarus:** Hotel Minsk Business Center, Bld. 3, r. 1211, Volodarski Str. 6,  
220050 MINSK, Tel. +375 172 20 0733, Fax. +375 172 20 0773

**Belgium:** see The Netherlands

**Brazil:** see South America

**Bulgaria:** Philips Bulgaria Ltd., Energoproject, 15th floor,  
51 James Bourchier Blvd., 1407 SOFIA,  
Tel. +359 2 68 9211, Fax. +359 2 68 9102

**Canada:** PHILIPS SEMICONDUCTORS/COMPONENTS,  
Tel. +1 800 234 7381, Fax. +1 800 943 0087

**China/Hong Kong:** 501 Hong Kong Industrial Technology Centre,  
72 Tat Chee Avenue, Kowloon Tong, HONG KONG,  
Tel. +852 2319 7888, Fax. +852 2319 7700

**Colombia:** see South America

**Czech Republic:** see Austria

**Denmark:** Sydhavnsgade 23, 1780 COPENHAGEN V,  
Tel. +45 33 29 3333, Fax. +45 33 29 3905

**Finland:** Sinikalliontie 3, FIN-02630 ESPOO,  
Tel. +358 9 615 800, Fax. +358 9 6158 0920

**France:** 51 Rue Carnot, BP317, 92156 SURESNES Cedex,  
Tel. +33 1 4099 6161, Fax. +33 1 4099 6427

**Germany:** Hammerbrookstraße 69, D-20097 HAMBURG,  
Tel. +49 40 2353 60, Fax. +49 40 2353 6300

**Hungary:** see Austria

**India:** Philips INDIA Ltd, Band Box Building, 2nd floor,  
254-D, Dr. Annie Besant Road, Worli, MUMBAI 400 025,  
Tel. +91 22 493 8541, Fax. +91 22 493 0966

**Indonesia:** PT Philips Development Corporation, Semiconductors Division,  
Gedung Philips, Jl. Buncit Raya Kav.99-100, JAKARTA 12510,  
Tel. +62 21 794 0040 ext. 2501, Fax. +62 21 794 0080

**Ireland:** Newstead, Clonskeagh, DUBLIN 14,  
Tel. +353 1 7640 000, Fax. +353 1 7640 200

**Israel:** RAPAC Electronics, 7 Kehilat Saloniki St, PO Box 18053,  
TEL AVIV 61180, Tel. +972 3 645 0444, Fax. +972 3 649 1007

**Italy:** PHILIPS SEMICONDUCTORS, Via Casati, 23 - 20052 MONZA (MI),  
Tel. +39 039 203 6838, Fax +39 039 203 6800

**Japan:** Philips Bldg 13-37, Kohnan 2-chome, Minato-ku,  
TOKYO 108-8507, Tel. +81 3 3740 5130, Fax. +81 3 3740 5057

**Korea:** Philips House, 260-199 Itaewon-dong, Yongsan-ku, SEOUL,  
Tel. +82 2 709 1412, Fax. +82 2 709 1415

**Malaysia:** No. 76 Jalan Universiti, 46200 PETALING JAYA, SELANGOR,  
Tel. +60 3 750 5214, Fax. +60 3 757 4880

**Mexico:** 5900 Gateway East, Suite 200, EL PASO, TEXAS 79905,  
Tel. +9-5 800 234 7381, Fax +9-5 800 943 0087

**Middle East:** see Italy

**Netherlands:** Postbus 90050, 5600 PB EINDHOVEN, Bldg. VB,  
Tel. +31 40 27 82785, Fax. +31 40 27 88399

**New Zealand:** 2 Wagener Place, C.P.O. Box 1041, AUCKLAND,  
Tel. +64 9 849 4160, Fax. +64 9 849 7811

**Norway:** Box 1, Manglerud 0612, OSLO,  
Tel. +47 22 74 8000, Fax. +47 22 74 8341

**Pakistan:** see Singapore

**Philippines:** Philips Semiconductors Philippines Inc.,  
106 Valero St. Salcedo Village, P.O. Box 2108 MCC, MAKATI,  
Metro MANILA, Tel. +63 2 816 6380, Fax. +63 2 817 3474

**Poland:** Al.Jerozolimskie 195 B, 02-222 WARSAW,  
Tel. +48 22 5710 000, Fax. +48 22 5710 001

**Portugal:** see Spain

**Romania:** see Italy

**Russia:** Philips Russia, Ul. Usatcheva 35A, 119048 MOSCOW,  
Tel. +7 095 755 6918, Fax. +7 095 755 6919

**Singapore:** Lorong 1, Toa Payoh, SINGAPORE 319762,  
Tel. +65 350 2538, Fax. +65 251 6500

**Slovakia:** see Austria

**Slovenia:** see Italy

**South Africa:** S.A. PHILIPS Pty Ltd., 195-215 Main Road Martindale,  
2092 JOHANNESBURG, P.O. Box 58088 Newville 2114,  
Tel. +27 11 471 5401, Fax. +27 11 471 5398

**South America:** Al. Vicente Pinzon, 173, 6th floor,  
04547-130 SÃO PAULO, SP, Brazil,  
Tel. +55 11 821 2333, Fax. +55 11 821 2382

**Spain:** Balmes 22, 08007 BARCELONA,  
Tel. +34 93 301 6312, Fax. +34 93 301 4107

**Sweden:** Kottbygatan 7, Akalla, S-16485 STOCKHOLM,  
Tel. +46 8 5985 2000, Fax. +46 8 5985 2745

**Switzerland:** Allmendstrasse 140, CH-8027 ZÜRICH,  
Tel. +41 1 488 2741 Fax. +41 1 488 3263

**Taiwan:** Philips Semiconductors, 6F, No. 96, Chien Kuo N. Rd., Sec. 1,  
TAIPEI, Taiwan Tel. +886 2 2134 2886, Fax. +886 2 2134 2874

**Thailand:** PHILIPS ELECTRONICS (THAILAND) Ltd.,  
209/2 Sanpavuth-Bangna Road Prakanong, BANGKOK 10260,  
Tel. +66 2 745 4090, Fax. +66 2 398 0793

**Turkey:** Yukari Dudullu, Org. San. Blg., 2.Cad. Nr. 28 81260 Umraniye,  
ISTANBUL, Tel. +90 216 522 1500, Fax. +90 216 522 1813

**Ukraine:** PHILIPS UKRAINE, 4 Patrice Lumumba str., Building B, Floor 7,  
252042 KIEV, Tel. +380 44 264 2776, Fax. +380 44 268 0461

**United Kingdom:** Philips Semiconductors Ltd., 276 Bath Road, Hayes,  
MIDDLESEX UB3 5BX, Tel. +44 208 730 5000, Fax. +44 208 754 8421

**United States:** 811 East Arques Avenue, SUNNYVALE, CA 94088-3409,  
Tel. +1 800 234 7381, Fax. +1 800 943 0087

**Uruguay:** see South America

**Vietnam:** see Singapore

**Yugoslavia:** PHILIPS, Trg N. Pasica 5/v, 11000 BEOGRAD,  
Tel. +381 11 62 5344, Fax.+381 11 63 5777

**For all other countries apply to:** Philips Semiconductors,  
International Marketing & Sales Communications, Building BE-p, P.O. Box 218,  
5600 MD EINDHOVEN, The Netherlands, Fax. +31 40 27 24825

**Internet:** <http://www.semiconductors.philips.com>

© Philips Electronics N.V. 1999

SCA 68

All rights are reserved. Reproduction in whole or in part is prohibited without the prior written consent of the copyright owner.

The information presented in this document does not form part of any quotation or contract, is believed to be accurate and reliable and may be changed without notice. No liability will be accepted by the publisher for any consequence of its use. Publication thereof does not convey nor imply any license under patent- or other industrial or intellectual property rights.

Printed in The Netherlands

545004/01/pp36

Date of release: 1999 Sep 24

Document order number: 9397 750 04621

*Let's make things better.*

**Philips**  
**Semiconductors**



**PHILIPS**