



# MICROCHIP MCP616/617/618/619

## 2.3V to 5.5V Micropower Bi-CMOS Op Amps

### FEATURES

- Low Power:  $I_{DD} = 25 \mu A$ , max
- Low Offset Voltage:  $150 \mu V$ , max
- Rail-to-Rail Swing at Output
- Low Input Offset Current:  $0.3 nA$ , typical
- Specifications rated for 2.3V to 5.5V Supplies
- Unity Gain Stable
- Chip Select (CS) Capability with MCP618
- Industrial Temperature range supported
- No Phase Reversal
- Available in Single, Dual, and Quad

### APPLICATIONS

- Battery Powered Instruments
- Strain Gauges
- Medical Instruments
- Test Equipment

### AVAILABLE TOOLS

- Spice Macromodels (at [www.microchip.com](http://www.microchip.com))
- FilterLab™ Software (at [www.microchip.com](http://www.microchip.com))

### HISTOGRAM OF INPUT OFFSET VOLTAGE

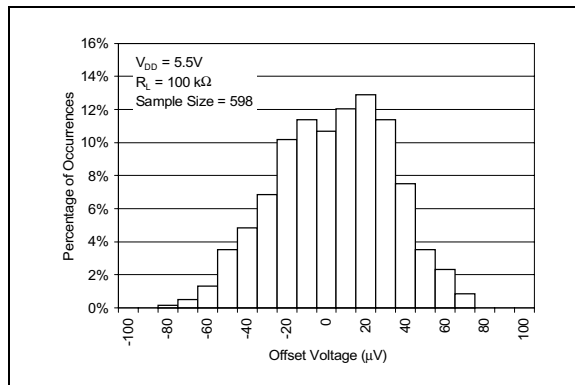

### DESCRIPTION

The MCP616, MCP617, MCP618 and MCP619 from Microchip Technology, Inc. are unity gain stable, low offset voltage operational amplifiers capable of precision low power single supply operation. Performance characteristics include ultra low offset voltage ( $150 \mu V$ , max.), rail-to-rail output swing capability, and low input offset current ( $0.3 nA$  typ.). These features make this family of amplifiers well suited for single supply precision, high impedance, battery powered applications.

The single MCP616 is available in standard 8-lead PDIP, SOIC, and MSOP packages. Another version of the single op amp, MCP618 is offered with a Chip Select (CS) option in standard 8-lead PDIP, SOIC, and MSOP packages. The dual MCP617 is offered in standard 8-lead PDIP, SOIC, as well as the MSOP package. Finally, the quad MCP619 is offered in 14-lead PDIP, SOIC and TSSOP packages. All devices are fully specified from  $-40^\circ C$  to  $+85^\circ C$  with power supplies from 2.3V to 5.5V.

### PACKAGES

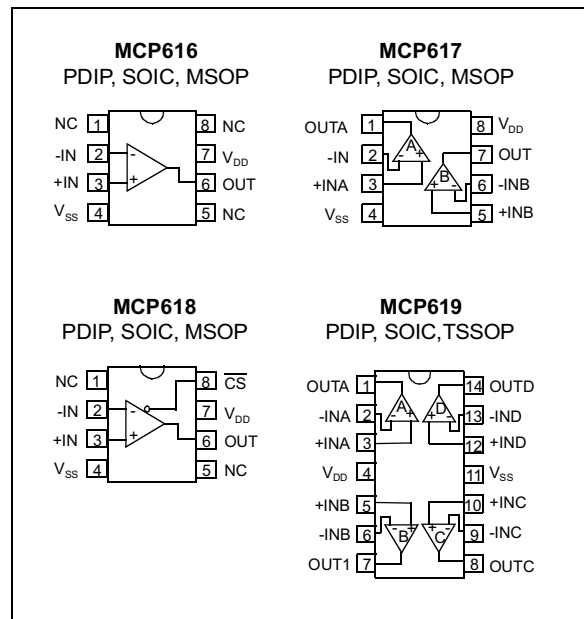

# MCP616/617/618/619

## 1.0 ELECTRICAL CHARACTERISTICS

### 1.1 Maximum Ratings†

$V_{DD}$ .....	7.0V
All inputs and outputs w.r.t. ... $V_{SS}$	-0.3V to $V_{DD} + 0.3V$
Difference Input voltage .....	$ V_{DD} - V_{SS} $
Output Short Circuit Current .....	continuous
Current at Input Pins .....	$\pm 2$ mA
Current at Output and Supply Pins .....	$\pm 30$ mA
Storage temperature .....	-65°C to +150°C
Ambient temp. with power applied .....	-55°C to +125°C
ESD protection on all pins (HBM).....	$\geq 4$ kV

† **Notice:** Stresses above those listed under "Maximum Ratings" may cause permanent damage to the device. This is a stress rating only and functional operation of the device at those or any other conditions above those indicated in the operational listings of this specification is not implied. Exposure to maximum rating conditions for extended periods may affect device reliability.

### PIN FUNCTION TABLE

Name	Function
+IN/+INA/+INB/+INC/+IND	Non-inverting Input Terminals
-IN/-INA/-INB/-INC/-IND	Inverting Input Terminals
$V_{DD}$	Positive Power Supply
$V_{SS}$	Negative Power Supply
OUT/OUTA/OUTB/OUTC/OUTD	Output Terminals
CS	Chip Select
NC	No internal connection to IC

## DC CHARACTERISTICS

Unless otherwise specified, all limits are specified for  $V_{DD} = +2.3V$  to  $+5.5V$ ,  $V_{SS} = GND$ ,  $T_A = 25^\circ C$ ,  $V_{CM} = V_{DD}/2$ ,  $R_L = 100$  k $\Omega$  to  $V_{DD}/2$ , and  $V_{OUT} \sim V_{DD}/2$

PARAMETERS	SYM.	MIN.	TYP.	MAX.	UNITS	CONDITIONS
<b>INPUT OFFSET</b>						
Input Offset Voltage	$V_{OS}$	-150	—	+150	$\mu V$	$T_A = -40^\circ C$ to $+85^\circ C$
Drift with Temperature	$dV_{OS}/dT$	—	$\pm 2$	—	$\mu V/^\circ C$	
Power Supply Rejection	PSRR	86	105	—	dB	
<b>INPUT BIAS CURRENT AND IMPEDANCE</b>						
Input Bias Current	$I_B$	-35	-15	-5	nA	$T_A = -40^\circ C$ to $+85^\circ C$
Over Temperature	$I_B$	-70	—	—	nA	
Input Offset Bias Current	$I_{OS}$	—	$\pm 0.3$	—	nA	
Common Mode Input Impedance	$Z_{CM}$	—	600  4	—	M $\Omega$   pF	
Differential Input Impedance	$Z_{DIFF}$	—	3  2	—	M $\Omega$   pF	
<b>COMMON MODE</b>						
Common-Mode Input Range	CMR	$V_{SS}$	—	$V_{DD} - 0.9$	V	$V_{DD} = 5V$ , $V_{CM} = 0.0$ to $4.1V$
Common-Mode Rejection Ratio	CMRR	80	100	—	dB	
<b>OPEN LOOP GAIN</b>						
DC Open Loop Gain	$A_{OL}$	100	120	—	dB	$R_L = 25$ k $\Omega$ to $V_{DD}/2$ , $50$ mV $< V_{OUT} <$ $(V_{DD} - 50$ mV)
DC Open Loop Gain	$A_{OL}$	95	115	—	dB	$R_L = 5$ k $\Omega$ to $V_{DD}/2$ , $100$ mV $< V_{OUT} <$ $(V_{DD} - 100$ mV)
<b>OUTPUT</b>						
Maximum Output Voltage Swing	$V_{OL}, V_{OH}$	$V_{SS} + 0.015$	—	$V_{DD} - 0.020$	V	$R_L = 25$ k $\Omega$ to $V_{DD}/2$
	$V_{OL}, V_{OH}$	$V_{SS} + 0.045$	—	$V_{DD} - 0.060$	V	$R_L = 5$ k $\Omega$ to $V_{DD}/2$
Linear Region Output Voltage Swing	$V_{OL}, V_{OH}$	$V_{SS} + 0.050$	—	$V_{DD} - 0.050$	V	$R_L = 25$ k $\Omega$ to $V_{DD}/2$ , $A_{OL} \geq 100$ dB
	$V_{OL}, V_{OH}$	$V_{SS} + 0.100$	—	$V_{DD} - 0.100$	V	$R_L = 5$ k $\Omega$ to $V_{DD}/2$ , $A_{OL} \geq 95$ dB
Output Short Circuit Current	$I_{SC}$	—	$\pm 17$	—	mA	$V_{OUT} = 2.75V$ , $V_{DD} = 5.5V$
<b>POWER SUPPLY</b>						
Supply Voltage	$V_S$	2.3	—	5.5	V	$I_O = 0$
Quiescent Current Per Amplifier	$I_Q$	12	19	25	$\mu A$	

# MCP616/617/618/619

## AC CHARACTERISTICS

Unless otherwise specified, all limits are specified for  $V_{DD} = +2.3V$  to  $+5.5V$ ,  $V_{SS} = GND$ ,  $T_A = 25^\circ C$ ,  $V_{CM} = V_{DD}/2$ ,  $R_L = 100\text{ k}\Omega$  to  $V_{DD}/2$ , and  $V_{OUT} \sim V_{DD}/2$

PARAMETERS	SYM.	MIN.	TYP.	MAX.	UNITS	CONDITIONS
Gain Bandwidth Product	GBWP	—	190	—	kHz	$G = 1$ , $V_{DD} = 5V$ , $C_L = 60\text{ pF}$
Phase Margin at Unity Crossing	$\theta$	—	57	—	degrees	$G = 1$ , $V_{DD} = 5V$ , $C_L = 60\text{ pF}$
Slew Rate	SR	—	0.08	—	V/ $\mu s$	$G = 1$ , $V_{DD} = 5V$ , $C_L = 60\text{ pF}$
Input Voltage Noise	$E_n$	—	2.2	—	$\mu V$ p-p	$f = 0.1\text{ Hz}$ to $10\text{ Hz}$
Noise Density	$e_n$	—	32	—	nV/ $\sqrt{\text{Hz}}$	$f \geq 1\text{ kHz}$
Input Current Noise Density	$i_n$	—	70	—	fA/ $\sqrt{\text{Hz}}$	$f \geq 1\text{ kHz}$

## SPECIFICATIONS FOR MCP618 CHIP SELECT ( $\overline{CS}$ ) FEATURE

Unless otherwise specified, all limits are specified for  $V_{DD} = +2.3V$  to  $+5.5V$ ,  $V_{SS} = GND$ ,  $T_A = 25^\circ C$ ,  $V_{CM} = V_{DD}/2$ ,  $R_L = 100\text{ k}\Omega$ , and  $V_{OUT} \sim V_{DD}/2$

PARAMETERS	SYM.	MIN.	TYP.	MAX.	UNITS	CONDITIONS
<b>CS LOW SPECIFICATIONS</b>						
$\overline{CS}$ Logic Threshold, Low	$V_{IL}$	$V_{SS}$	—	$0.2 V_{DD}$	V	For entire $V_{DD}$ range
$\overline{CS}$ Input Current, Low	$I_{CSL}$	-1.0	0.01	—	$\mu A$	$\overline{CS} = 0.2V_{DD}$
<b>CS HIGH SPECIFICATIONS</b>						
$\overline{CS}$ Logic Threshold, High	$V_{IH}$	$0.8 V_{DD}$	—	$V_{DD}$	V	For entire $V_{DD}$ range
$\overline{CS}$ Input Current, High	$I_{CSH}$	—	0.01	2	$\mu A$	$\overline{CS} = V_{DD}$
$\overline{CS}$ Input High, GND Current	$I_Q$	—	0.05	2	$\mu A$	$\overline{CS} = V_{DD}$
Amplifier Output Leakage, $\overline{CS}$ High	—	—	0.01	—	$\mu A$	$\overline{CS} = 0.8V_{DD}$
<b>DYNAMIC SPECIFICATIONS</b>						
$\overline{CS}$ Low to Amplifier Output High Turn-on Time	$t_{ON}$	—	9	100	$\mu s$	$\overline{CS}$ low = $0.2V_{DD}$ , $V_{OUT} = 0.9 * V_{DD}/2$ , $G = +1V/V$
$\overline{CS}$ High to Amplifier Output High Z	$t_{OFF}$	—	0.1	—	$\mu s$	$\overline{CS}$ high = $0.8V_{DD}$ , $V_{OUT} = 0.1 * V_{DD}/2$ , $G = +1V/V$
Hysteresis	—	—	0.6	—	V	$V_{DD} = 5V$

## TEMPERATURE SPECIFICATIONS

Unless otherwise specified, all limits are specified for  $V_{DD} = +2.3V$  to  $+5.5V$ ,  $V_{SS} = GND$

PARAMETERS	SYM.	MIN.	TYP.	MAX.	UNITS	CONDITIONS
<b>TEMPERATURE RANGES</b>						
Specified Temperature Range	$T_A$	-40	—	+85	$^\circ C$	
Operating Temperature Range	$T_A$	-40	—	+85	$^\circ C$	
Storage Temperature Range	$T_A$	-65	—	+150	$^\circ C$	
<b>THERMAL PACKAGE RESISTANCE</b>						
Thermal Resistance, 8L-PDIP	$\theta_{JA}$	—	85	—	$^\circ C/W$	
Thermal Resistance, 8L-SOIC	$\theta_{JA}$	—	163	—	$^\circ C/W$	
Thermal Resistance, 8L-MSOP	$\theta_{JA}$	—	206	—	$^\circ C/W$	
Thermal Resistance, 14L-PDIP	$\theta_{JA}$	—	70	—	$^\circ C/W$	
Thermal Resistance, 14L-SOIC	$\theta_{JA}$	—	120	—	$^\circ C/W$	
Thermal Resistance, 14L-TSSOP	$\theta_{JA}$	—	100	—	$^\circ C/W$	

# MCP616/617/618/619

## 2.0 TYPICAL PERFORMANCE CURVES

**Note:** Unless otherwise indicated,  $T_A = 25^\circ\text{C}$ ,  $V_{CM} = V_{DD} / 2$  and  $V_{OUT} \sim V_{DD}/2$ ,  $V_{SS} = \text{GND}$

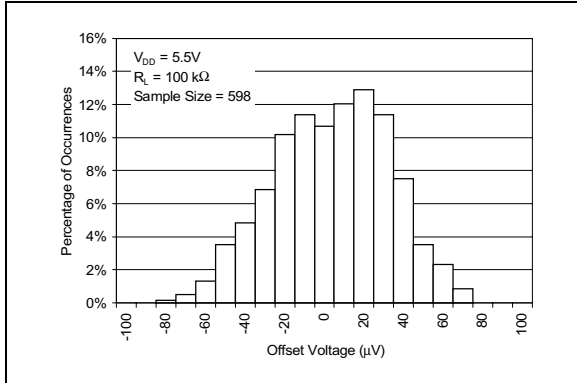

**FIGURE 2-1:** Histogram of Offset Voltage with  $V_{DD} = 5.5\text{V}$ .

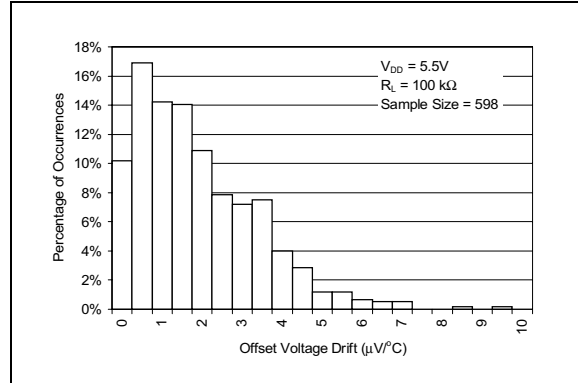

**FIGURE 2-4:** Histogram of Offset Voltage Drift with  $V_{DD} = 5.5\text{V}$ .

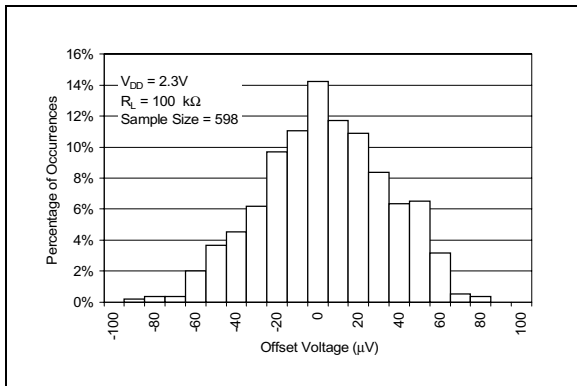

**FIGURE 2-2:** Histogram of Offset Voltage with  $V_{DD} = 2.3\text{V}$ .

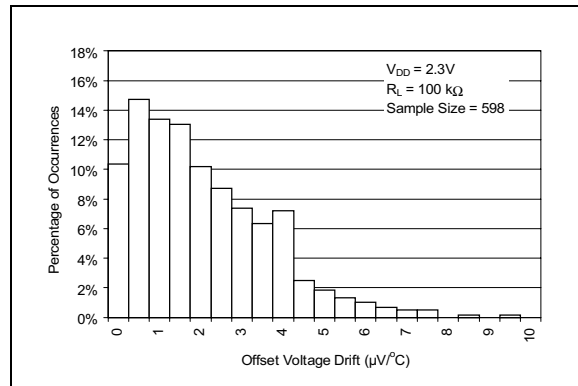

**FIGURE 2-5:** Histogram of Offset Voltage Drift with  $V_{DD} = 2.3\text{V}$ .

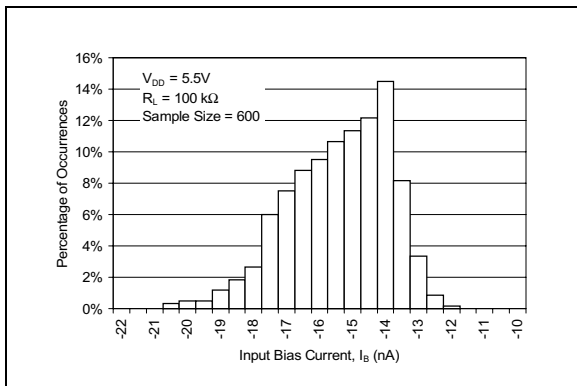

**FIGURE 2-3:** Histogram of Input Bias Current with  $V_{DD} = 5.5\text{V}$ .

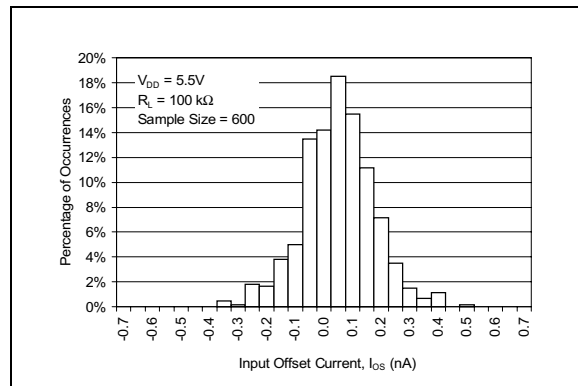

**FIGURE 2-6:** Histogram of Input Offset Current with  $V_{DD} = 5.5\text{V}$ .

# MCP616/617/618/619

**Note:** Unless otherwise indicated,  $T_A = 25^\circ\text{C}$ ,  $V_{CM} = V_{DD} / 2$  and  $V_{OUT} \sim V_{DD}/2$ ,  $V_{SS} = \text{GND}$

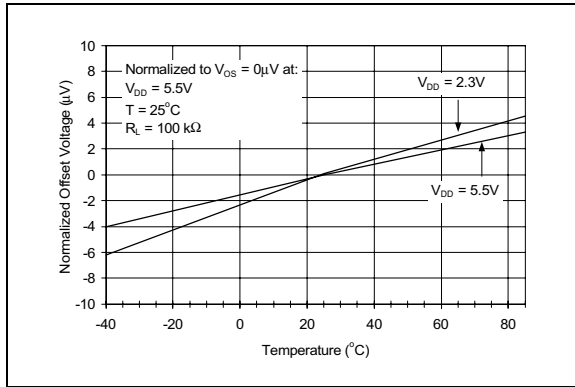

**FIGURE 2-7:** Normalized Offset Voltage vs. Temperature.

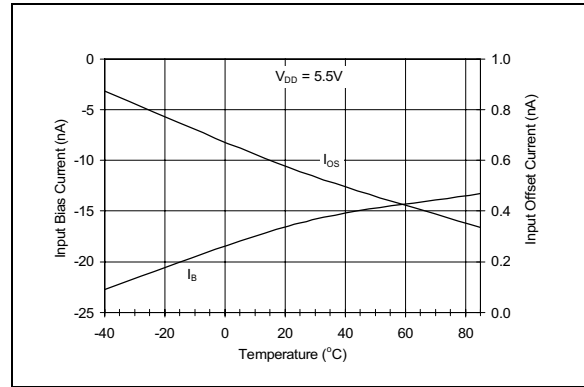

**FIGURE 2-10:** Input Bias Current, Input Offset Current vs. Temperature.

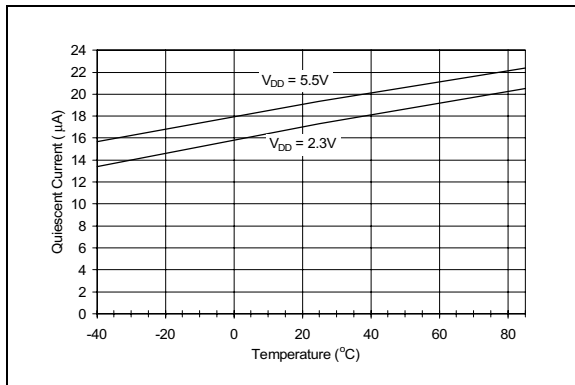

**FIGURE 2-8:** Quiescent Current vs. Temperature vs. Power Supply Voltage.

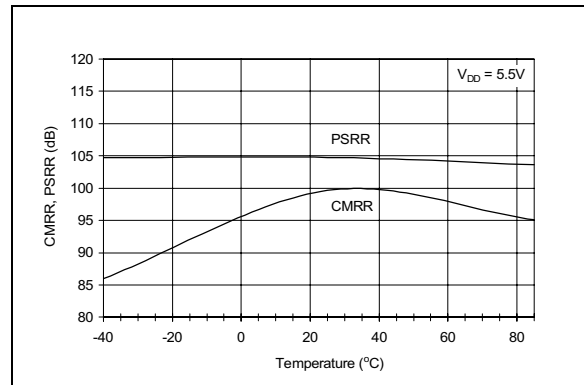

**FIGURE 2-11:** Common Mode Rejection Ratio, Power Supply Rejection Ratio vs. Temperature.

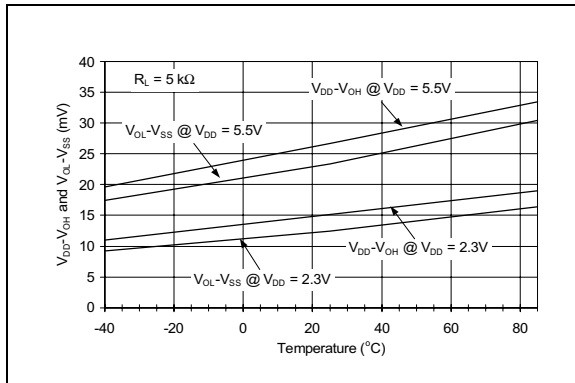

**FIGURE 2-9:** Maximum Output Voltage Swing vs. Temperature with  $R_L = 5\text{ k}\Omega$ .

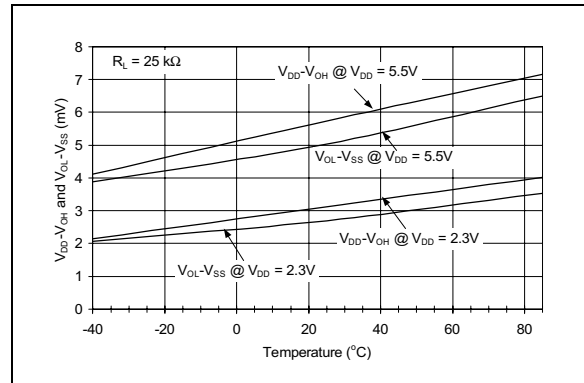

**FIGURE 2-12:** Maximum Output Voltage Swing vs. Temperature with  $R_L = 25\text{ k}\Omega$ .

# MCP616/617/618/619

**Note:** Unless otherwise indicated,  $T_A = 25^\circ\text{C}$ ,  $V_{CM} = V_{DD} / 2$  and  $V_{OUT} \sim V_{DD}/2$ ,  $V_{SS} = \text{GND}$

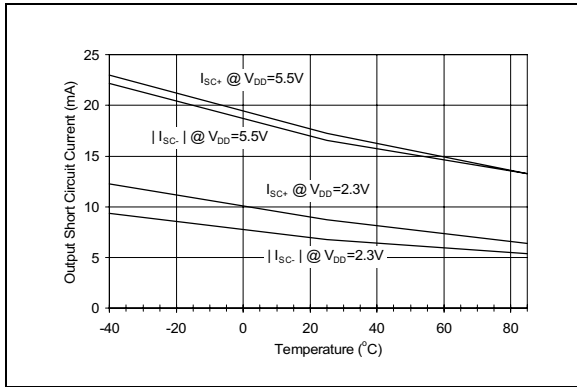

**FIGURE 2-13:** Output Short Circuit Current vs. Temperature vs. Power Supply Voltage.

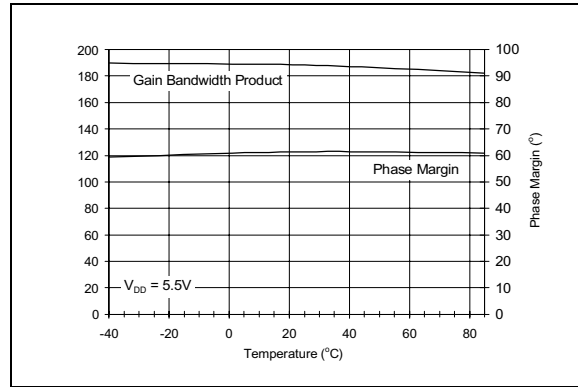

**FIGURE 2-16:** Gain Bandwidth Product, Phase Margin vs. Temperature.

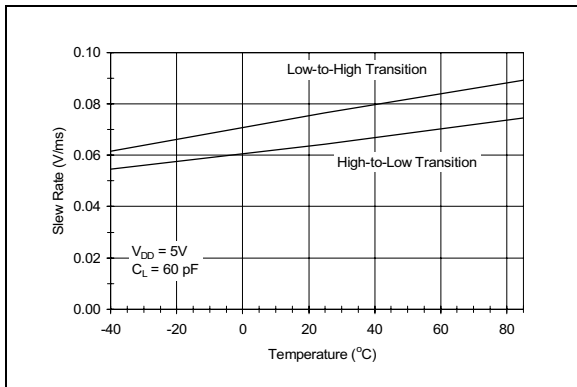

**FIGURE 2-14:** Slew Rate vs. Temperature.

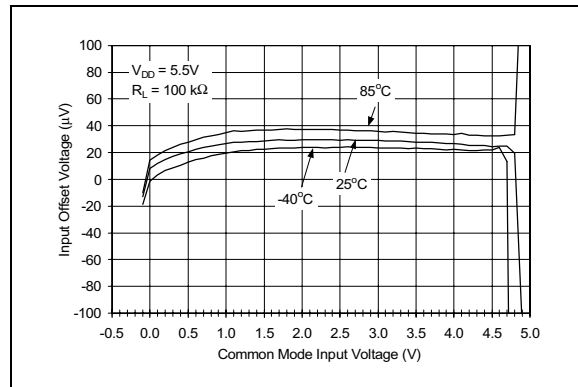

**FIGURE 2-17:** Input Offset Voltage vs. Common Mode Input Voltage vs. Temperature.

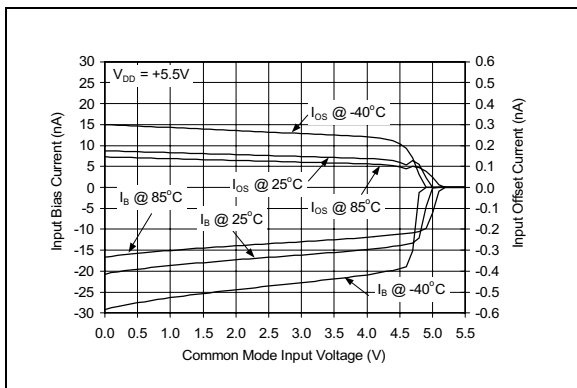

**FIGURE 2-15:** Input Bias and Offset Current vs. Common Mode Input Voltage vs. Temperature.

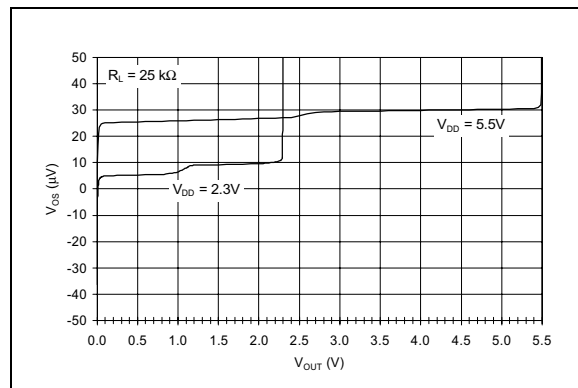

**FIGURE 2-18:** Input Offset Voltage vs. Output Voltage.

# MCP616/617/618/619

**Note:** Unless otherwise indicated,  $T_A = 25^\circ\text{C}$ ,  $V_{CM} = V_{DD} / 2$  and  $V_{OUT} \sim V_{DD}/2$ ,  $V_{SS} = \text{GND}$

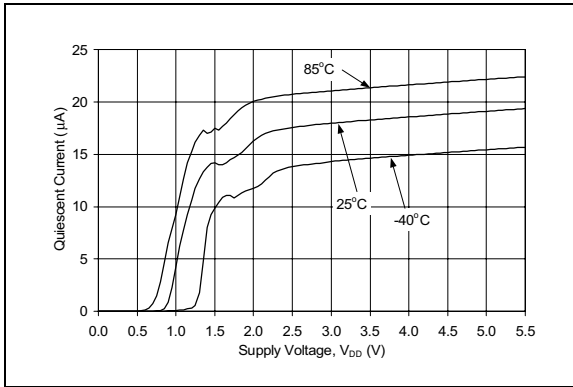

**FIGURE 2-19:** Quiescent Current vs. Power Supply Voltage vs. Temperature.

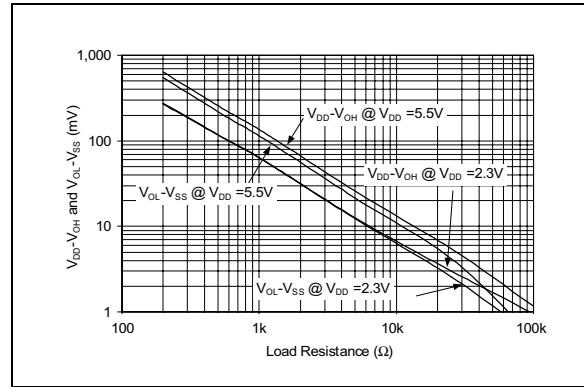

**FIGURE 2-22:** Maximum Output Voltage Swing vs. Load Resistance.

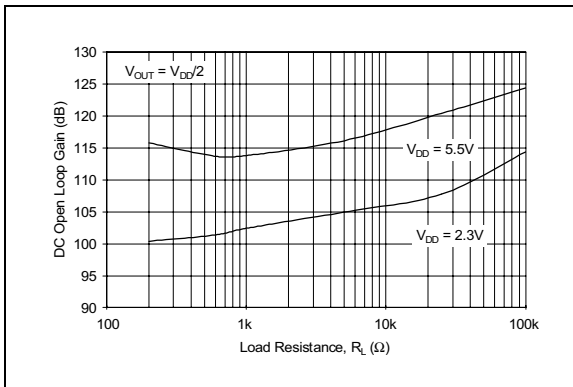

**FIGURE 2-20:** DC Open Loop Gain vs. Load Resistance vs. Power Supply Voltage.

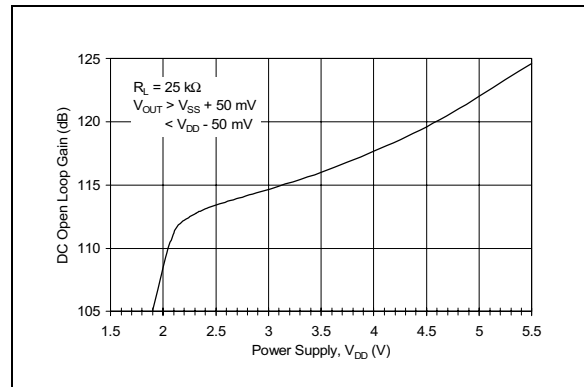

**FIGURE 2-23:** DC Open Loop Gain vs. Power Supply Voltage.

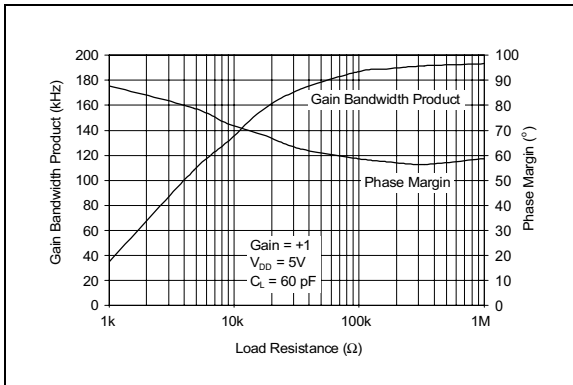

**FIGURE 2-21:** Gain Bandwidth Product, Phase Margin vs. Load Resistance.

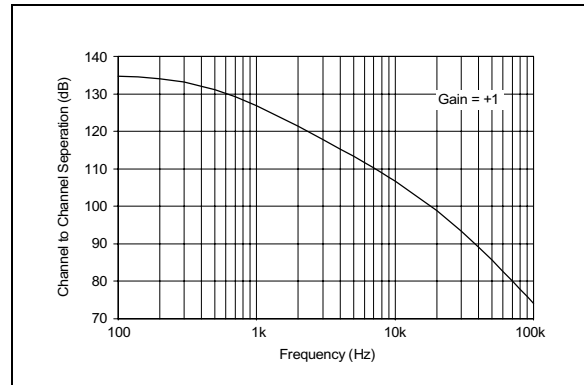

**FIGURE 2-24:** Channel to Channel Separation vs. Frequency (MCP617 and MCP619 only).

# MCP616/617/618/619

**Note:** Unless otherwise indicated,  $T_A = 25^\circ\text{C}$ ,  $V_{CM} = V_{DD} / 2$  and  $V_{OUT} \sim V_{DD}/2$ ,  $V_{SS} = \text{GND}$

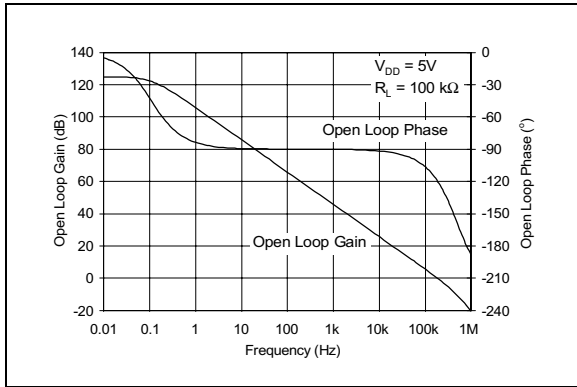

**FIGURE 2-25:** Open Loop Gain, Phase vs. Frequency.

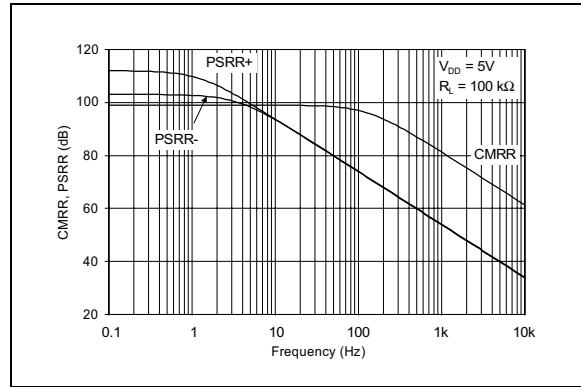

**FIGURE 2-28:** Common-Mode Rejection Ratio, Power Supply Rejection Ratio vs. Frequency.

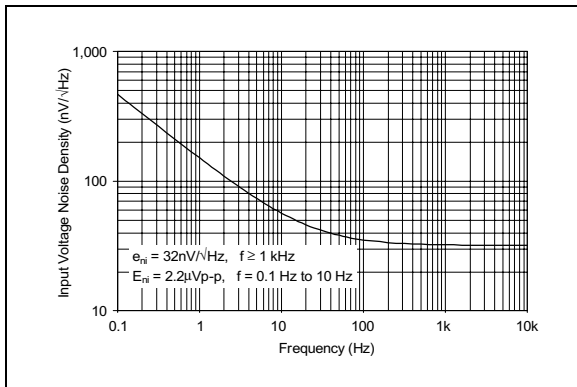

**FIGURE 2-26:** Input Voltage Noise Density vs. Frequency.

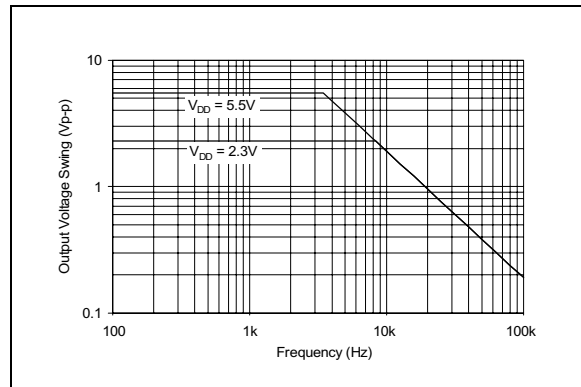

**FIGURE 2-29:** Maximum Output Voltage Swing vs. Frequency.

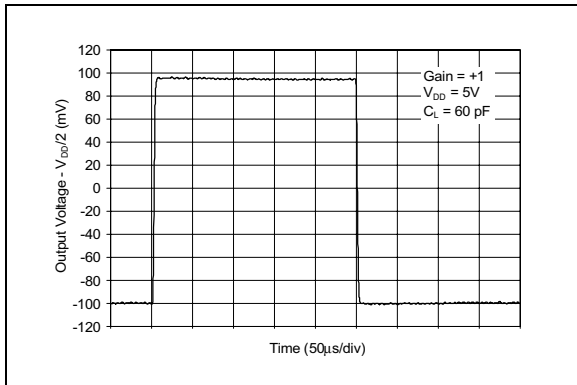

**FIGURE 2-27:** Small Signal Non-Inverting Pulse Response.

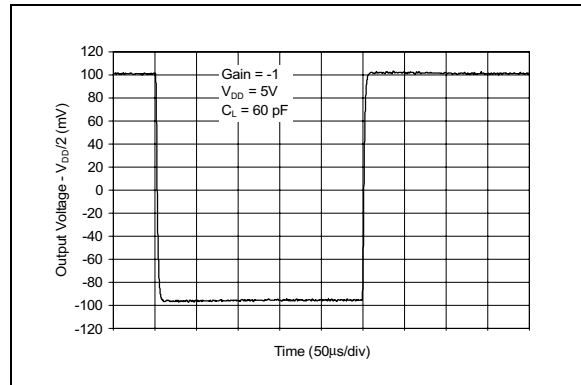
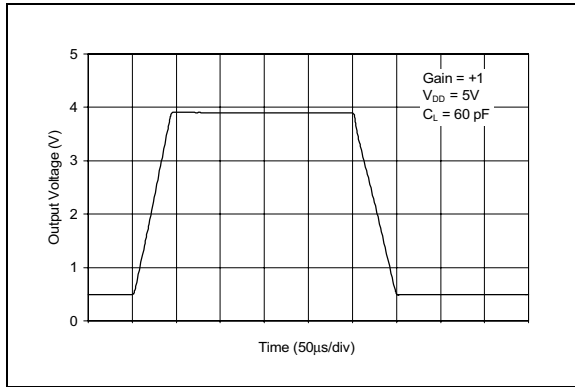

**FIGURE 2-30:** Small Signal Inverting Pulse Response.



# MCP616/617/618/619

**Note:** Unless otherwise indicated,  $T_A = 25^\circ\text{C}$ ,  $V_{CM} = V_{DD} / 2$  and  $V_{OUT} \sim V_{DD}/2$ ,  $V_{SS} = \text{GND}$



**FIGURE 2-31:** Large Signal Non-Inverting Pulse Response.

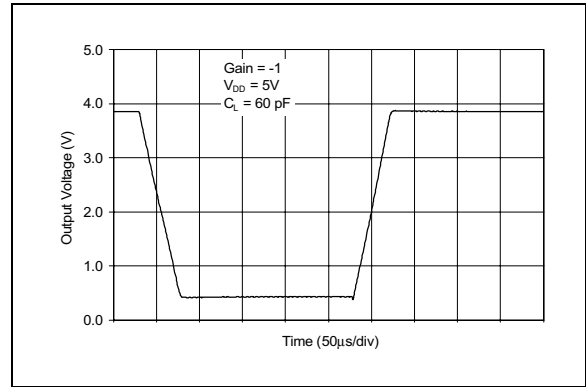

**FIGURE 2-33:** Large Signal Inverting Pulse Response.

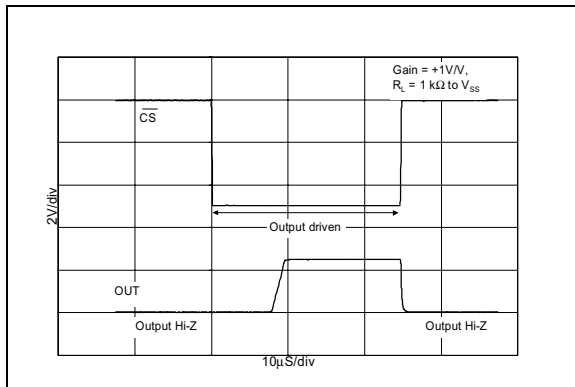

**FIGURE 2-32:**  $\overline{\text{CS}}$  to Amplifier Output Response Time (MCP618 only).

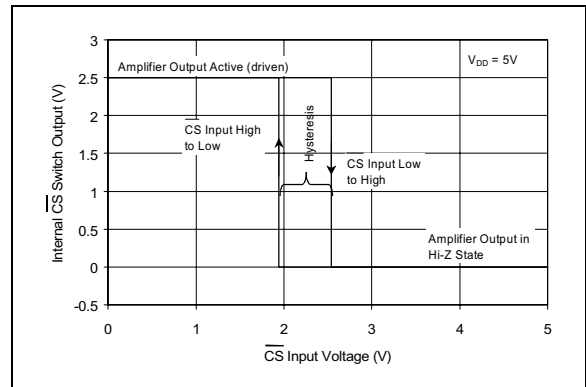

**FIGURE 2-34:**  $\overline{\text{CS}}$  Hysteresis (MCP618 only).

# MCP616/617/618/619

## 3.0 APPLICATIONS INFORMATION

The MCP616/617/618/619 family of operational amplifiers are fabricated on Microchip's state-of-the-art CMOS process. They are unity gain stable and suitable for a wide range of general purpose applications. With this family of operational amplifiers, the power supply pin should be by-passed with a 0.1  $\mu\text{F}$  capacitor.

### 3.1 Rail-to-Rail Output Swing

There are two specifications that describe the output swing capability of the MCP616/617/618/619 family of operational amplifiers. The first specification, Maximum Output Voltage Swing, defines the absolute maximum swing that can be achieved under specified loaded conditions. For instance, the MCP616/617/618/619 family is specified to be able to swing at least to 15 mV from the negative rail with a 25 k $\Omega$  load to  $V_{DD}/2$ . This output swing performance is shown in Figure 3-1, where the output of an MCP616 is configured in a gain of +2V/V and overdriven with a 4 kHz triangle wave.

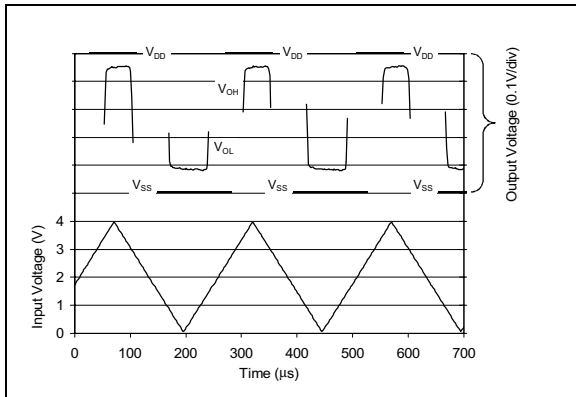

**FIGURE 3-1:** Maximum Output Voltage Swing.

The second specification that describes the output swing capability of these amplifiers is the Linear Region Output Voltage Swing. This specification defines the maximum output swing that can be achieved while the amplifier is still operating in its linear region. For instance, the open loop gain is  $\geq 100$  dB for a 25 k $\Omega$  load over the specified range of  $V_{SS} + 0.050\text{V}$  and  $V_{DD} - 0.050\text{V}$ .

The classical definition of the DC open loop gain of an amplifier is:

$$A_{OL} = 20 \log_{10} \left( \frac{\Delta V_{OUT}}{\Delta V_{OS}} \right)$$

where:

$A_{OL}$  is the DC open loop gain of the amplifier

$\Delta V_{OUT}$  is the change in  $V_{OUT}$  while in the Linear Region Output Voltage swing spec

$\Delta V_{OS}$  is the change in input offset voltage with the change in  $V_{OUT}$

### 3.2 Input Voltage and Phase Reversal

The MCP616/617/618/619 amplifier family is designed with CMOS devices and PNP input transistors. It is designed to not exhibit phase inversion when the input pins exceed the supply voltages. Figure 3-2 shows an input voltage exceeding both supplies with no resulting phase inversion.

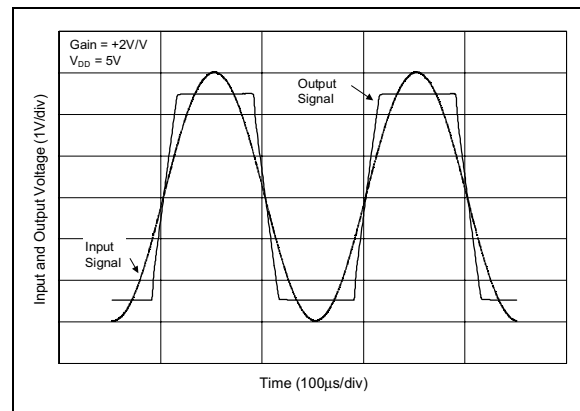

**FIGURE 3-2:** The MCP616/617/618/619 family of op amps do not have phase reversal issues. For this graph, the amplifier is in a gain of +2V/V.

The maximum operating common-mode voltage that can be applied to the inputs is  $V_{SS}$  to  $V_{DD} - 0.9V$ . In contrast, the absolute maximum input voltage is  $V_{SS} - 0.3V$  and  $V_{DD} + 0.3V$ . Voltages on the input that exceed this absolute maximum rating can cause excessive current to flow in or out of the input pins. Current beyond  $\pm 2\text{ mA}$  can cause possible reliability problems. Applications that exceed this rating must be externally limited with an input resistor as shown in Figure 3-3.

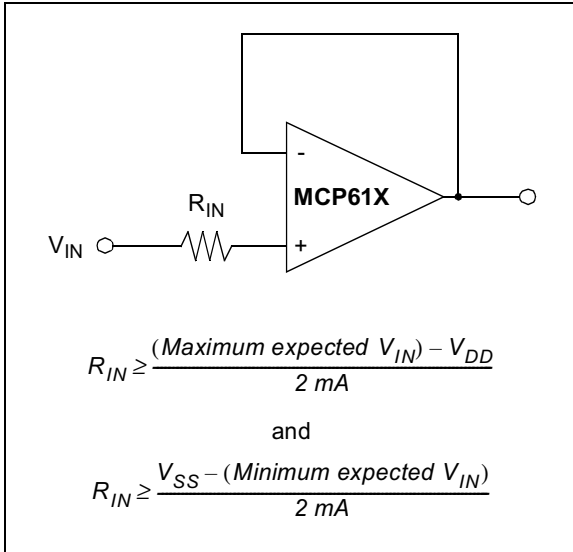

**FIGURE 3-3:** If the inputs of the amplifier exceed the Absolute Maximum Specifications, an input resistor,  $R_{IN}$ , should be used to limit the current flow into that pin.

### 3.3 Capacitive Load and Stability

Driving capacitive loads can cause stability problems with many of the higher speed amplifiers.

For any closed loop amplifier circuit, a good rule of thumb is to design for a phase margin that is no less than  $45^\circ$ . This is a conservative theoretical value, however, if the phase margin is lower, layout parasitics can degrade the phase margin further causing a truly unstable circuit. A system with  $45^\circ$  phase margin will have an overshoot in its step response of approximately 25%.

A buffer configuration with a capacitive load is the most difficult configuration for an amplifier to maintain stability. The Phase versus Capacitive Load of the amplifier is shown in Figure 3-4. In this figure, it can be seen that the amplifier has a phase margin above  $45^\circ$ , while driving capacitance loads up to 150 pF. This figure also shows that higher capacitive loads reduce the bandwidth of the amplifier.

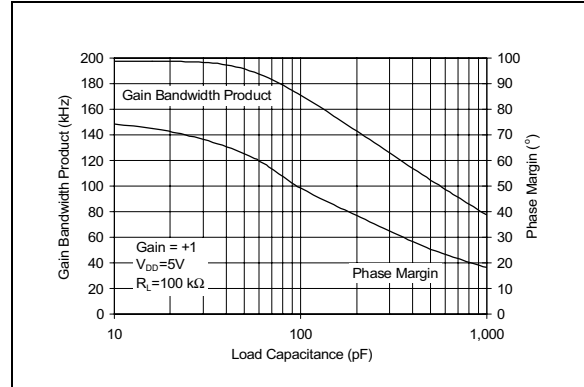

**FIGURE 3-4:** Gain Bandwidth Product, Phase Margin vs. Capacitive Load.

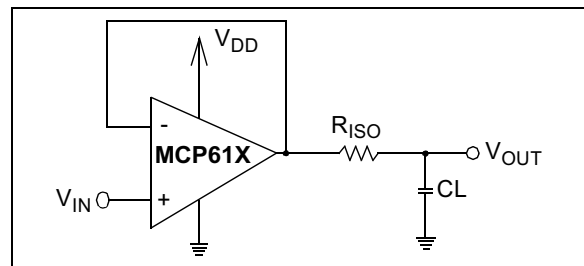

**FIGURE 3-5:** Amplifier circuits that can be used when driving heavy capacitive loads.

If the amplifier is required to drive larger capacitive loads, the circuit shown in Figure 3-5 can be used. A small series resistor ( $R_{ISO}$ ) at the output of the amplifier improves the phase margin when driving large capacitive loads. This resistor decouples the capacitive load from the amplifier by introducing a zero in the transfer function. It will not, however, significantly improve the bandwidth for larger capacitive loads.

This zero adjusts the phase margin by approximately:

$$\Delta\theta_m = \tan^{-1}(2\pi GBWP \times R_{ISO} \times C_L)$$

where:

$\Delta\theta_m$  is the improvement in phase margin,

$GBWP$  is the gain bandwidth product of the amplifier,

$R_{ISO}$  is the capacitive decoupling resistor, and

$C_L$  is the load capacitance

# MCP616/617/618/619

## 3.4 DC Offsets

The MCP616/617/618/619 amplifier family has very low offset voltage (150  $\mu\text{V}$  max at  $T_A = 25^\circ\text{C}$ ). These amplifiers use a PNP transistor input stage with a typical bias currents of -15 nA, which must have a DC path to ground or the op amp will not bias properly. The DC resistances seen by the op amp inputs ( $R_2$  and  $R_F \parallel R_1$  in Figure 3-6) need to be equal to minimize DC offsets. Also keep these resistance  $\leq 100$  k $\Omega$  for low DC offset.

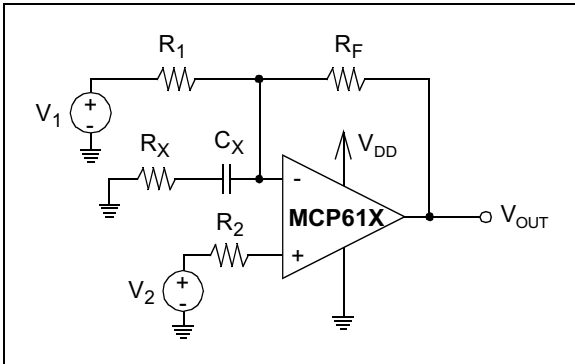

**FIGURE 3-6:** Circuit for calculating DC Offset.

To calculate the DC offset ( $\Delta V_{OUT}$ ), first simplify the circuit to its DC equivalent.

- Replace capacitors with open circuits
- Replace inductors with short circuits
- Replace AC voltage sources with short circuits
- Replace AC current sources with open circuits
- Convert DC sources and resistances into Theiving equivalent form

Second, calculate the nominal DC bias point. Note that current is positive going into the op amp, so the bias current spec shows current sourced out of the inputs.

$$V_{CM} = V_2 - I_B R_2$$

$$G_N = 1 + R_F / R_1$$

$$V_{OUT} = V_2(G_N) - V_1(G_N - 1)$$

Where:

$V_{CM}$  is the common mode voltage at the op amp inputs

$G_N$  is the DC gain from the non-inverting input to  $V_{OUT}$

Third, calculate the DC error voltage caused by the op amp.

$$\Delta V_{OUT} = G_N V_{OS} + G_N I_B (R_F \parallel R_1 - R_2) - G_N I_{OS} \frac{R_F \parallel R_1 + R_2}{2}$$

Last, use the values in the DC Characteristics table to determine the worst case  $V_{OUT} + \Delta V_{OUT}$  for your design. Make sure that the output voltage range is not exceeded.

Note that with very high input DC resistances, the output may exceed the linear region output voltage swing specification, and the op amp will saturate. Keep the input resistances below 100 k $\Omega$  to help prevent this from happening.

## 3.5 The Chip Select Option of the MCP618

The MCP618 is a single amplifier with a Chip Select ( $\overline{CS}$ ) option. When  $\overline{CS}$  is pulled high the supply current drops to 50 nA (typ). In this state, the amplifier is put into a high impedance state. By pulling  $\overline{CS}$  low, the amplifier is enabled. If the CS pin is left floating, the amplifier will not operate properly. Figure 3-7 shows the output voltage and supply current response to a  $\overline{CS}$  pulse.

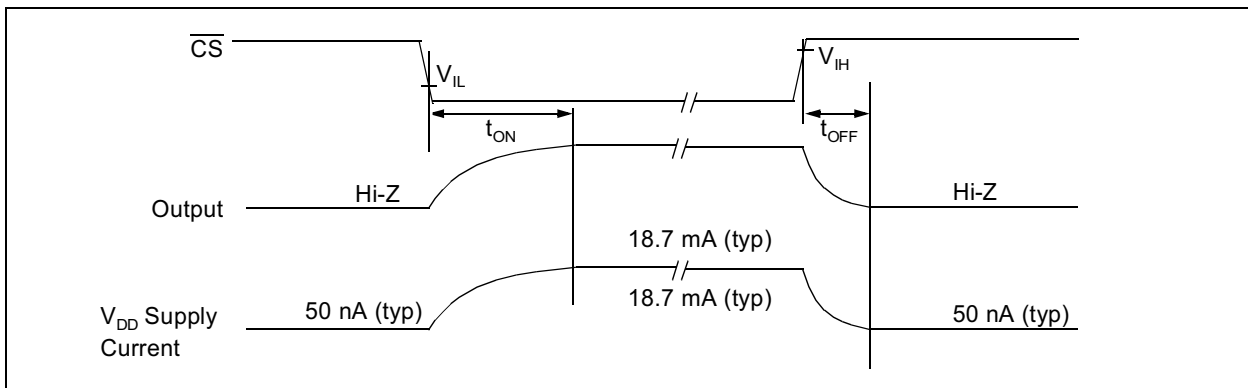

**FIGURE 3-7:** Timing Diagram for the  $\overline{CS}$  Function of the MCP618 Amplifier.

## 3.6 Layout Considerations

Good PC board layout techniques will help you achieve the performance shown in the specs and Typical Performance Curves. It will also help you minimize EMC (Electro-Magnetic Compatibility) issues.

### 3.6.1 COMPONENT PLACEMENT

Partition the board layout into different sections to minimize crosstalk. Digital and analog functions should be separated from each other. High speed and low speed parts should be kept apart whenever possible.

Keep important signal traces as short as possible, especially high frequency (low rise time) signals. This reduces the signal's exposure to interference. Other traces, such as supply lines, can be longer. Place analog parts in the signal path close together.

Use a 0.1  $\mu$ F supply bypass capacitor within 0.1" (2.5 mm) of the  $V_{DD}$  pin. It should connect directly to the ground plane, in order to minimize ground loops.

### 3.6.2 SIGNAL COUPLING

The input pins of the MCP616/617/618/619 amplifiers are high impedance, which allows noise injection if good layout techniques are not followed. Current can be injected into the inputs from another trace with fast changing voltages, such as digital clock. This current is coupled capacitively between the traces.

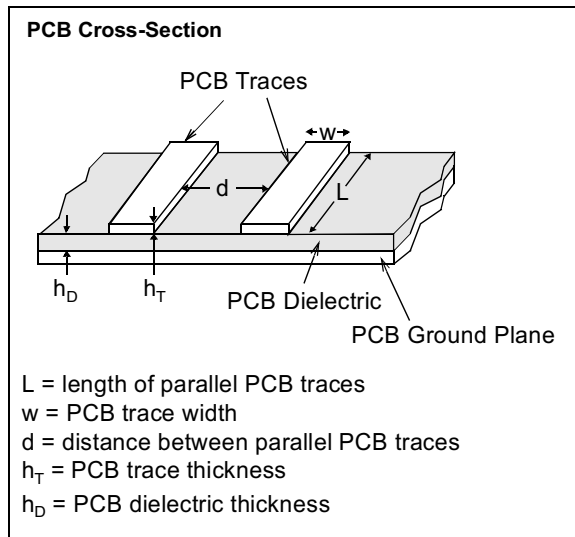

**FIGURE 3-8:** Capacitors can be built with PCB traces, allowing signals to couple from one trace to another.

The PCB layout shown in Figure 3-8 produces parasitic capacitances as shown in Figure 3-9. The resistor  $R_{T2}$  includes the op amp input resistance, and any additional resistance the designer ties from the trace to ground.

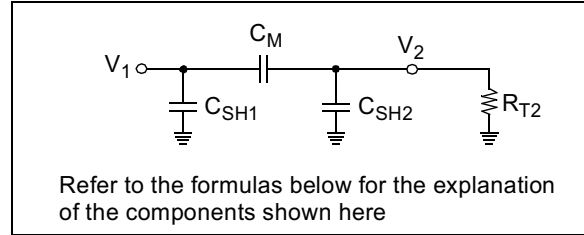

**FIGURE 3-9:** Equivalent circuit for Figure 3-8.

The signal,  $V_1$  is coupled to the sensitive trace through the mutual capacitance,  $C_M$ . The terminating resistor,  $R_{T2}$  attenuates the coupled signal at low frequencies, and the shunt capacitor,  $C_{SH2}$  at high frequencies. Without the ground plane ( $C_{SH2} = 0$ ),  $V_1$  would appear without attenuation on the sensitive trace at high frequencies. The capacitances  $C_M$ ,  $C_{SH1}$  and  $C_{SH2}$  can be approximated with these formulas:

$$C_M \approx \frac{h_T L \epsilon_0 \epsilon_r}{d}$$

$$C_{SH1} = C_{SH2} \approx \frac{L w \epsilon_0 \epsilon_r}{h_d}$$

Where:

- $V_1$  = interfering voltage signal
- $C_M$  = mutual capacitance
- $C_{SH1}$  = shunt capacitance at  $V_1$
- $C_{SH2}$  = shunt capacitance at sensitive trace
- $R_{T2}$  = optional terminating resistance attached to sensitive trace

To reduce this capacitively coupled signal,

1. Always use ground plane.
  - a. Put ground plane and sensitive traces in adjacent PCB layers.
  - b. Inject large currents into the ground plane far away from sensitive traces.
2. Minimize interfering signal strength.
  - a. Keep the edge rates on digital signals low.
  - b. Limit the bandwidth of analog signals.
  - c. Keep interfering traces far apart.
  - d. Minimize distance interfering traces are in parallel.
3. Dissipate interfering signals at sensitive traces.
  - a. Make sensitive traces as wide and short as possible.
  - b. Connect a low-valued shunt resistor from sensitive trace to ground.

# MCP616/617/618/619

## 3.7 Typical Applications

### 3.7.1 HIGH GAIN PRE-AMPLIFIER

The MCP616/617/618/619 amplifiers are well suited to amplifying small signals produced by low impedance sources/sensors. The low offset voltage, low offset current, and low noise fit well in this role. Figure 3-10 shows a typical pre-amplifier connected to a low impedance source ( $V_S$  and  $R_S$ ).

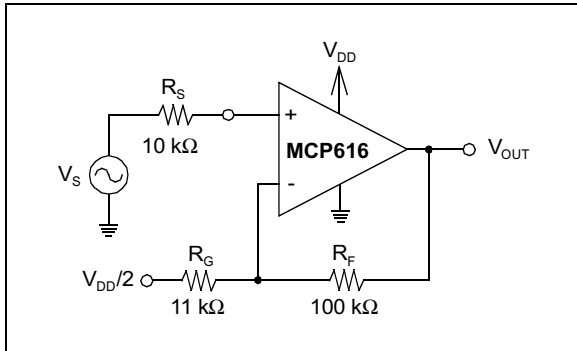
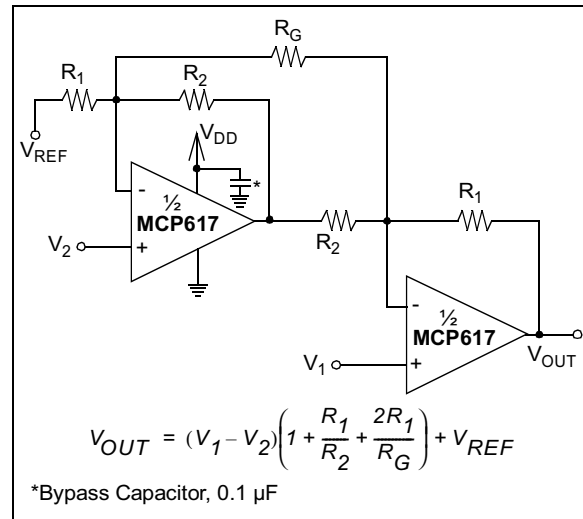

**FIGURE 3-10:** High gain pre-amplifier for low resistance sources.

For the best noise and offset performance, the source resistance  $R_S$  needs to be  $\leq 15 \text{ k}\Omega$ . The DC resistances at the inputs are equal to minimize the offset voltage caused by the input bias currents. In this circuitry, the DC gain is  $10V/V$ , which will give a typical bandwidth of 16 kHz.

### 3.7.2 TWO OP AMP INSTRUMENTATION AMPLIFIER

The two op amp instrumentation amplifier shown in Figure 3-11 serves the function of taking the difference of two input voltages, level shifting then and providing a single output. This configuration is best suited for higher gains. The key specifications that make the MCP616/617/618/619 family appropriate for this application circuit is low offset voltage and high common-mode rejection. The reference voltage ( $V_{REF}$ ) of this circuit is supplied to the first op amp in the signal chain. Typically, this voltage is half of the supply voltage in a single supply environment.



**FIGURE 3-11:** Two Op Amp Instrumentation Amplifiers.

### 3.7.3 THREE OP AMP INSTRUMENTATION AMPLIFIER

A classic, three op amp instrumentation amplifier is illustrated in Figure 3-12. The input operational amplifiers in this circuit provide signal gain. The output operational amplifier converts the signal from two inputs to a single ended output with a difference amplifier. The gain of this circuit is simply adjusted with one resistor,  $R_G$ . The reference voltage ( $V_{REF}$ ) of the difference stage of this instrumentation amplifier is capable of spanning a wide range. Most typically, this node is referenced to half of the supply voltage in a signal supply application.

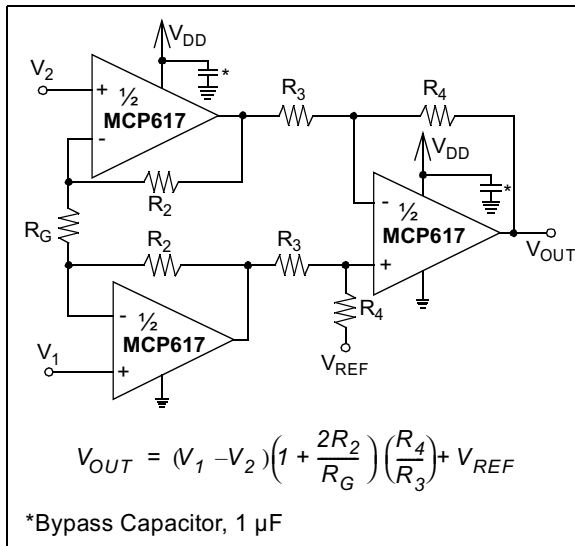

**FIGURE 3-12:** Three Op Amp Instrumentation Amplifiers.

### 3.7.4 PRECISION GAIN WITH GOOD LOAD ISOLATION

In Figure 3-13, the low input offset voltage of the MCP616 is used to implement a circuit with a high gain. This precision measurement can easily be disrupted by changing the output current drive of the device that is doing the amplification work. Consequently, the precision amplifier configuration is followed by a MCP601 amplifier which is capable of driving higher currents. Since the two amplifiers are housed in separate packages, there is minimal change in offset voltage of the MCP616 due to loading effects.

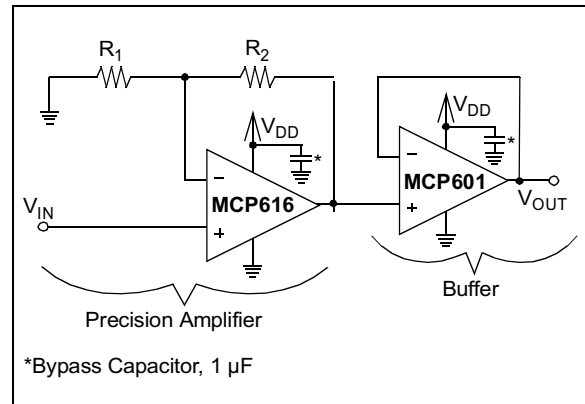

**FIGURE 3-13:** Precision Gain with Good Load Isolation.

# MCP616/617/618/619

---

## 4.0 SPICE MACROMODEL

The Spice macromodel for the MCP616, MCP617, MCP618 and MCP619 simulates the typical amplifier performance of offset voltage, DC power supply rejection, input capacitance, DC common mode rejection ratio, open loop gain over frequency, phase margin with no capacitive load, output swing, DC power supply current, power supply current change with supply voltage, input common mode range and input voltage noise.

The characteristics of the MCP616, MCP617, MCP618, and MCP619 amplifiers are similar in terms of performance and behavior. This single op amp macromodel supports all four devices with the exception of the chip select ( $\overline{CS}$ ) function of the MCP618, which is not modeled.

The listing for this macromodel is shown on the next page. The most recent revision of the model can be downloaded from Microchip's web site at [www.microchip.com](http://www.microchip.com).



## Software License Agreement

The software supplied herewith by Microchip Technology Incorporated (the "Company") for its PICmicro® Microcontroller is intended and supplied to you, the Company's customer, for use solely and exclusively on Microchip PICmicro Microcontroller products.

The software is owned by the Company and/or its supplier, and is protected under applicable copyright laws. All rights are reserved. Any use in violation of the foregoing restrictions may subject the user to criminal sanctions under applicable laws, as well as to civil liability for the breach of the terms and conditions of this license.

THIS SOFTWARE IS PROVIDED IN AN "AS IS" CONDITION. NO WARRANTIES, WHETHER EXPRESS, IMPLIED OR STATUTORY, INCLUDING, BUT NOT LIMITED TO, IMPLIED WARRANTIES OF MERCHANTABILITY AND FITNESS FOR A PARTICULAR PURPOSE APPLY TO THIS SOFTWARE. THE COMPANY SHALL NOT, IN ANY CIRCUMSTANCES, BE LIABLE FOR SPECIAL, INCIDENTAL OR CONSEQUENTIAL DAMAGES, FOR ANY REASON WHATSOEVER.

```
.SUBCKT MCP616 1 2 3 4 5
*
*      | | | | |
*      | | | | Output
*      | | | Negative Supply
*      | | Positive Supply
*      | Inverting Input
*      Non-inverting Input
*
* Macromodel for MCP616 (single), MCP617 (dual), MCP618 (single w/CS), and MCP619 (quad)
*
* The characteristics of the MCP616, MCP617, MCP618, and MCP619 have the same fundamental
* performance and behavior. Consequently, this single op amp macromodel supports all four
* devices. However, the chip select function of the MCP618 is not modeled.
*
* Revision History:
* REV A : 2-23-01 created KEB
*
* This macromodel models typical amplifier offset voltage, DC power supply rejection, input
* capacitance, open loop gain over frequency, phase margin with 60pF load, output swing,
* power supply current, input voltage noise, slew rate.
*
* NOTICE: THE INFORMATION PROVIDED HEREIN IS BELIEVED TO BE RELIABLE,
* HOWEVER, MICROCHIP ASSUMES NO RESPONSIBILITY FOR INACCURACIES OR
* OMISSIONS. MICROCHIP ASSUMES NO RESPONSIBILITY FOR THE USE OF THIS
* INFORMATION, AND ALL USE OF SUCH INFORMATION SHALL BE ENTIRELY AT
* THE USER'S OWN RISK. NO INTELLECTUAL PROPERTY RIGHTS OR LICENSES
* TO ANY OF THE TECHNOLOGY DESCRIBED HEREIN ARE IMPLIED OR GRANTED TO
* ANY THIRD PARTY. MICROCHIP RESERVES THE RIGHT TO CHANGE THIS MODEL
* AT ANY TIME WITHOUT NOTICE.
*
*Input Stage, pole at 300kHz
*
Q1      9 64 7 PQ
Q2      8 2 7 PQ
CDM     1 2 2P
IOS     1 2 400P
CCM1    1 4 4P
CCM2    2 4 4P
IDD     3 7 13.3U
DCT     20 3 DX
VCT     20 7 1.10
RA      8 6 5.53K
RB      9 6 5.53K
CA      8 9 48.0P
VCMM    4 6 0.45
ICOMP   4 3 195U
*
```

# MCP616/617/618/619

---

\* Input Stage Common-Mode Clamping

\*

ECM 55 4 3 64 1

RCM 57 56 1K

DCMP 56 55 DY

VCMP 57 4 1.2

RST 58 59 1K

DST 59 55 DX

VST 58 4 1.6

GCMP2 23 4 POLY(2) 57 56 58 59 0 0 0;0 -500U 500U

\*

\* Input Errors (vos, en, psr)

\*

ERR 64 1 poly(2) 67 4 3 4 -50U 2.3 6U

\*

\* Second Stage, pole at 0.19Hz

\*

GS 23 4 8 9 181U

R1 23 4 5.53G

C2 23 4 166P

VSOM 3 24 4.784

VSOP 25 4 -3.98

DSOM 23 24 DY

DSOP 25 23 DY

\*HCM 23 3 VCMP

FS 3 4 POLY(11) VO3 VO5 VO4 VO6 VO1 VO2 VO9 VO10 VMID1 VSOP VSOM

+ 200U -1 -1 -1 1 -1 -1 1 1 -1 -1 -1

\*

\* Mid-supply Reference

\*

RMID1 3 35 61.62K

VMID1 35 34 0

RMID2 4 34 61.62K

ELEVEL 34 4 23 4 -1

\*

\* Output Stage

\*

DO3 34 43 DY

DO4 44 34 DY

DO5 3 45 DY

DO6 3 46 DY

DO7 4 45 DY

DO8 4 46 DY

VO3 43 5 0.1

VO4 5 44 30M

GO5 3 47 3 34 10M

VO5 47 5 0

GO6 4 48 34 4 10M

VO6 48 5 0

GO1 49 4 5 34 10M

VO1 49 45 0

GO2 50 4 34 5 10M

VO2 50 46 0

RO9 3 51 100

VO9 51 5 0

RO10 52 4 100

VO10 52 5 0

# MCP616/617/618/619

---

---

```
*
* Input Voltage Noise
VN1  65  4  0.6
DN1  65 67  DX
RN1  67  4 10K
*
* Models
*
.model PQ PNP (IS=0.1F BF=440 VAF=70 RB=1K)
.model DY D (IS=1F BV=50)
.model DX D (IS=0.001F AF=1.0 KF=55F)
*
.ENDS MCP616
```

# MCP616/617/618/619

## 5.0 PACKAGING INFORMATION

### 5.1 Package Marking Information

8-Lead PDIP (300 mil)

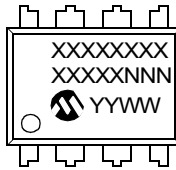

Example:

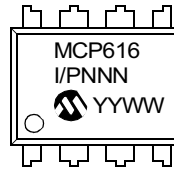

8-Lead SOIC (150 mil)

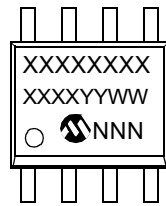

Example:

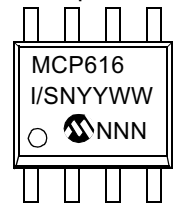

8-Lead MSOP

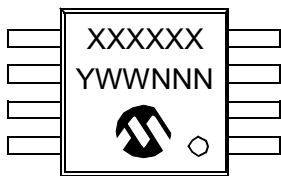

Example:

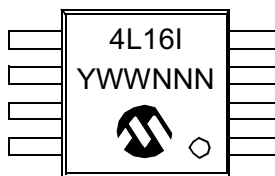

<b>Legend:</b>	XX...X	Customer specific information*
	YY	Year code (last 2 digits of calendar year)
	WW	Week code (week of January 1 is week '01')
	NNN	Alphanumeric traceability code

**Note:** In the event the full Microchip part number cannot be marked on one line, it will be carried over to the next line thus limiting the number of available characters for customer specific information.

\* Standard marking consists of Microchip part number, year code, week code, traceability code (facility code, mask rev#, and assembly code). For marking beyond this, certain price adders apply. Please check with your Microchip Sales Office.

# MCP616/617/618/619

## Package Marking Information (Continued)

14-Lead PDIP (300 mil)(MCP619)

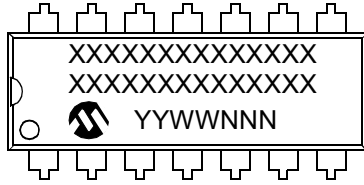

Example:

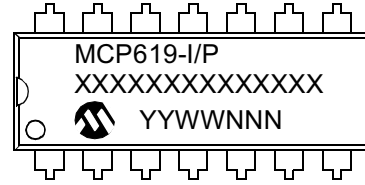

14-Lead SOIC (150 mil)(MCP619)

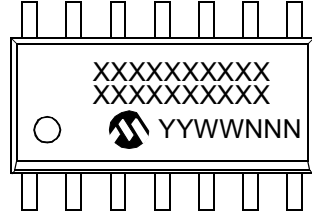

Example:

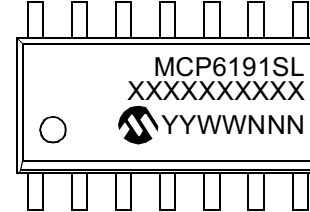

14-Lead TSSOP(MCP619)

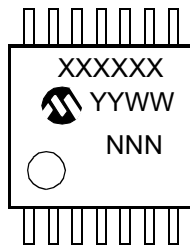

Example:

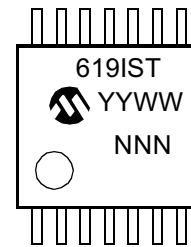

<b>Legend:</b>	XX...X	Customer specific information*
	YY	Year code (last 2 digits of calendar year)
	WW	Week code (week of January 1 is week '01')
	NNN	Alphanumeric traceability code

**Note:** In the event the full Microchip part number cannot be marked on one line, it will be carried over to the next line thus limiting the number of available characters for customer specific information.

- \* Standard marking consists of Microchip part number, year code, week code, traceability code (facility code, mask rev#, and assembly code). For marking beyond this, certain price adders apply. Please check with your Microchip Sales Office.

# MCP616/617/618/619

## 8-Lead Plastic Dual In-line (P) – 300 mil (PDIP)

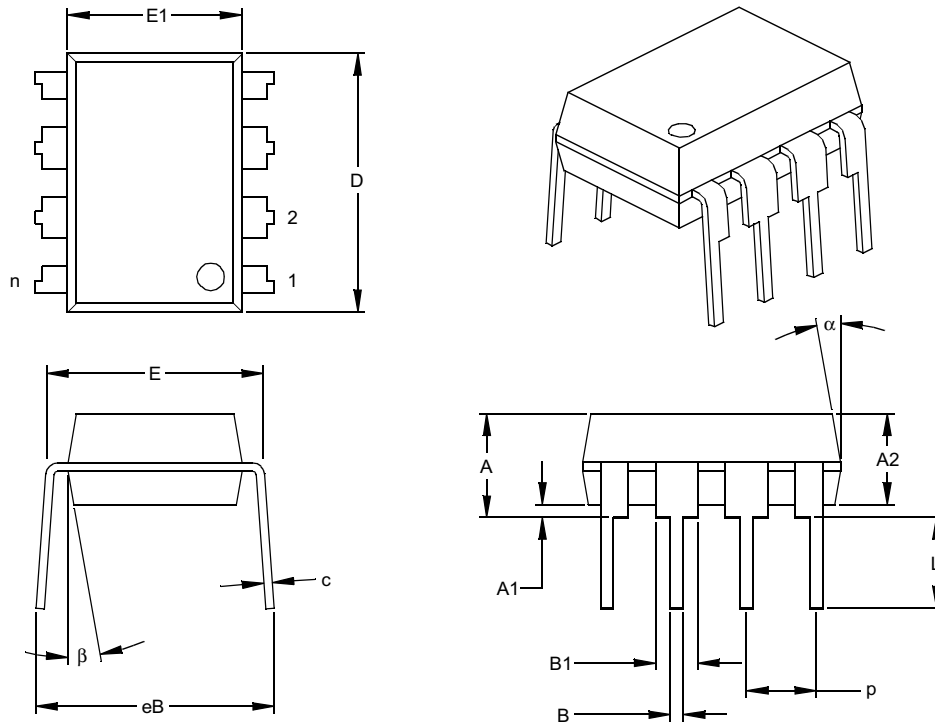

Dimension Limits	Units	INCHES*			MILLIMETERS		
		MIN	NOM	MAX	MIN	NOM	MAX
Number of Pins	n		8			8	
Pitch	p		.100			2.54	
Top to Seating Plane	A	.140	.155	.170	3.56	3.94	4.32
Molded Package Thickness	A2	.115	.130	.145	2.92	3.30	3.68
Base to Seating Plane	A1	.015			0.38		
Shoulder to Shoulder Width	E	.300	.313	.325	7.62	7.94	8.26
Molded Package Width	E1	.240	.250	.260	6.10	6.35	6.60
Overall Length	D	.360	.373	.385	9.14	9.46	9.78
Tip to Seating Plane	L	.125	.130	.135	3.18	3.30	3.43
Lead Thickness	c	.008	.012	.015	0.20	0.29	0.38
Upper Lead Width	B1	.045	.058	.070	1.14	1.46	1.78
Lower Lead Width	B	.014	.018	.022	0.36	0.46	0.56
Overall Row Spacing	§ eB	.310	.370	.430	7.87	9.40	10.92
Mold Draft Angle Top	α	5	10	15	5	10	15
Mold Draft Angle Bottom	β	5	10	15	5	10	15

\* Controlling Parameter

§ Significant Characteristic

### Notes:

Dimensions D and E1 do not include mold flash or protrusions. Mold flash or protrusions shall not exceed .010" (0.254mm) per side.

JEDEC Equivalent: MS-001

Drawing No. C04-018

# MCP616/617/618/619

## 8-Lead Plastic Small Outline (SN) – Narrow, 150 mil (SOIC)

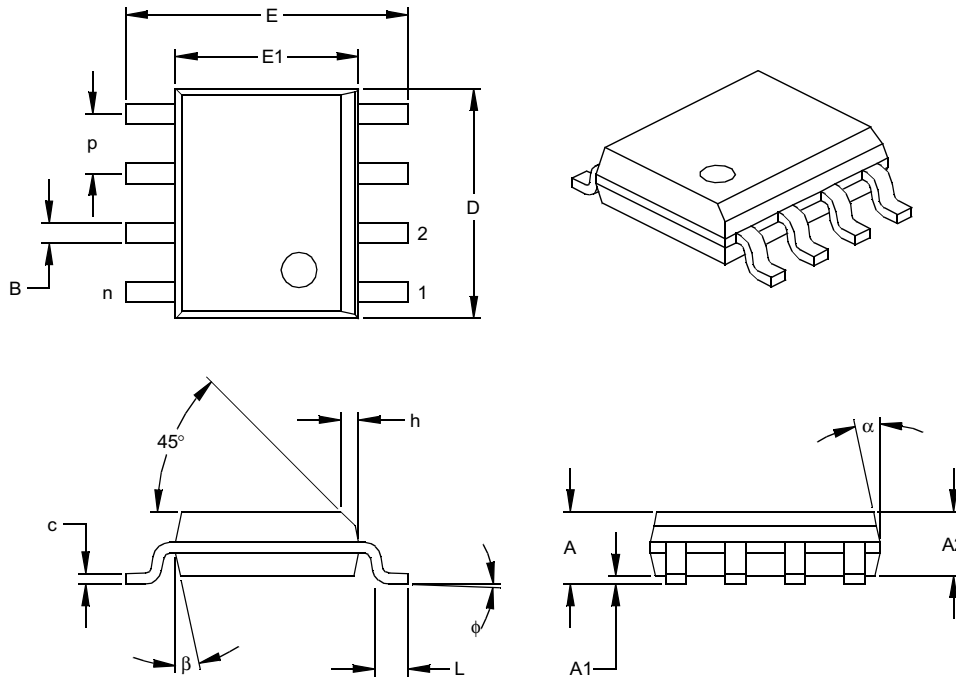

Units		INCHES*			MILLIMETERS		
Dimension	Limits	MIN	NOM	MAX	MIN	NOM	MAX
Number of Pins	n		8			8	
Pitch	p		.050			1.27	
Overall Height	A	.053	.061	.069	1.35	1.55	1.75
Molded Package Thickness	A2	.052	.056	.061	1.32	1.42	1.55
Standoff §	A1	.004	.007	.010	0.10	0.18	0.25
Overall Width	E	.228	.237	.244	5.79	6.02	6.20
Molded Package Width	E1	.146	.154	.157	3.71	3.91	3.99
Overall Length	D	.189	.193	.197	4.80	4.90	5.00
Chamfer Distance	h	.010	.015	.020	0.25	0.38	0.51
Foot Length	L	.019	.025	.030	0.48	0.62	0.76
Foot Angle	φ	0	4	8	0	4	8
Lead Thickness	c	.008	.009	.010	0.20	0.23	0.25
Lead Width	B	.013	.017	.020	0.33	0.42	0.51
Mold Draft Angle Top	α	0	12	15	0	12	15
Mold Draft Angle Bottom	β	0	12	15	0	12	15

\* Controlling Parameter  
 § Significant Characteristic

**Notes:**

Dimensions D and E1 do not include mold flash or protrusions. Mold flash or protrusions shall not exceed .010" (0.254mm) per side.

JEDEC Equivalent: MS-012

Drawing No. C04-057

# MCP616/617/618/619

## 8-Lead Plastic Micro Small Outline Package (MS) (MSOP)

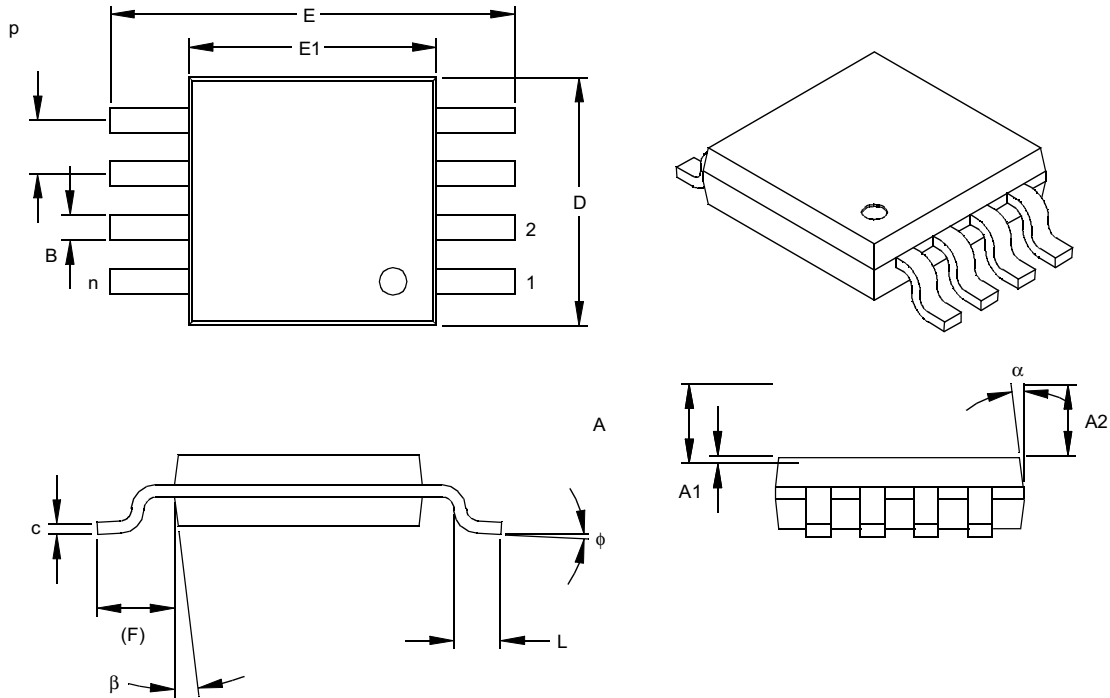

Units		INCHES			MILLIMETERS*		
Dimension Limits		MIN	NOM	MAX	MIN	NOM	MAX
Number of Pins	n		8				8
Pitch	p	.026			0.65		
Overall Height	A			.044			1.18
Molded Package Thickness	A2	.030	.034	.038	0.76	0.86	0.97
Standoff §	A1	.002		.006	0.05		0.15
Overall Width	E	.184	.193	.200	4.67	4.90	5.08
Molded Package Width	E1	.114	.118	.122	2.90	3.00	3.10
Overall Length	D	.114	.118	.122	2.90	3.00	3.10
Foot Length	L	.016	.022	.028	0.40	0.55	0.70
Footprint (Reference)	F	.035	.037	.039	0.90	0.95	1.00
Foot Angle	φ	0		6	0		6
Lead Thickness	c	.004	.006	.008	0.10	0.15	0.20
Lead Width	B	.010	.012	.016	0.25	0.30	0.40
Mold Draft Angle Top	α		7			7	
Mold Draft Angle Bottom	β		7			7	

\*Controlling Parameter  
 § Significant Characteristic

Notes:

Dimensions D and E1 do not include mold flash or protrusions. Mold flash or protrusions shall not exceed .010" (0.254mm) per side.

Drawing No. C04-111



# MCP616/617/618/619

## 14-Lead Plastic Dual In-line (P) – 300 mil (PDIP)

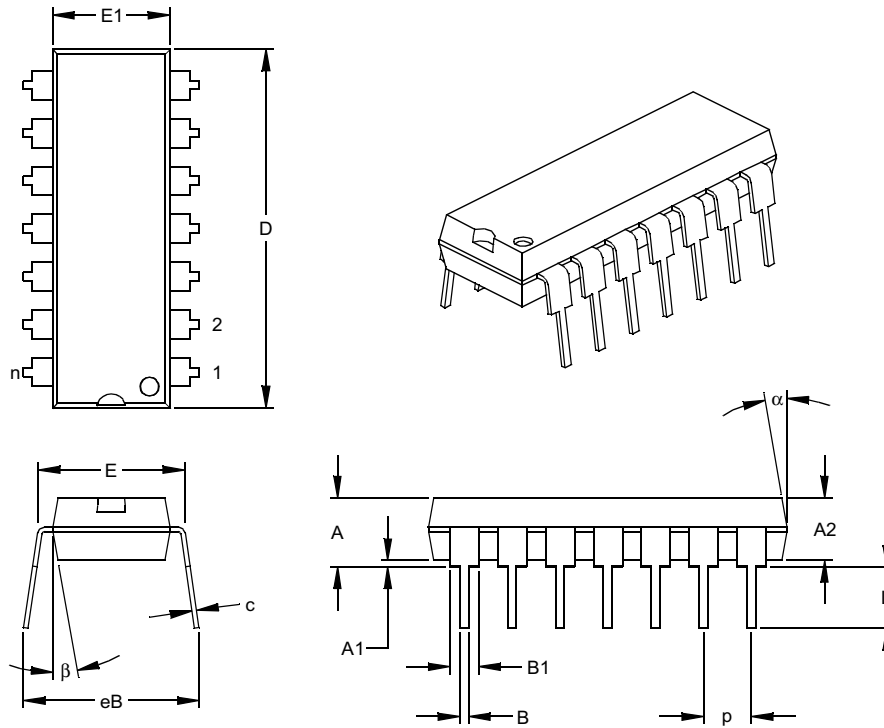

Units		INCHES*			MILLIMETERS		
Dimension	Limits	MIN	NOM	MAX	MIN	NOM	MAX
Number of Pins	n		14			14	
Pitch	p		.100			2.54	
Top to Seating Plane	A	.140	.155	.170	3.56	3.94	4.32
Molded Package Thickness	A2	.115	.130	.145	2.92	3.30	3.68
Base to Seating Plane	A1	.015			0.38		
Shoulder to Shoulder Width	E	.300	.313	.325	7.62	7.94	8.26
Molded Package Width	E1	.240	.250	.260	6.10	6.35	6.60
Overall Length	D	.740	.750	.760	18.80	19.05	19.30
Tip to Seating Plane	L	.125	.130	.135	3.18	3.30	3.43
Lead Thickness	c	.008	.012	.015	0.20	0.29	0.38
Upper Lead Width	B1	.045	.058	.070	1.14	1.46	1.78
Lower Lead Width	B	.014	.018	.022	0.36	0.46	0.56
Overall Row Spacing	§ eB	.310	.370	.430	7.87	9.40	10.92
Mold Draft Angle Top	α	5	10	15	5	10	15
Mold Draft Angle Bottom	β	5	10	15	5	10	15

\* Controlling Parameter

§ Significant Characteristic

Notes:

Dimensions D and E1 do not include mold flash or protrusions. Mold flash or protrusions shall not exceed .010" (0.254mm) per side.

JEDEC Equivalent: MS-001

Drawing No. C04-005

# MCP616/617/618/619

## 14-Lead Plastic Small Outline (SL) – Narrow, 150 mil (SOIC)

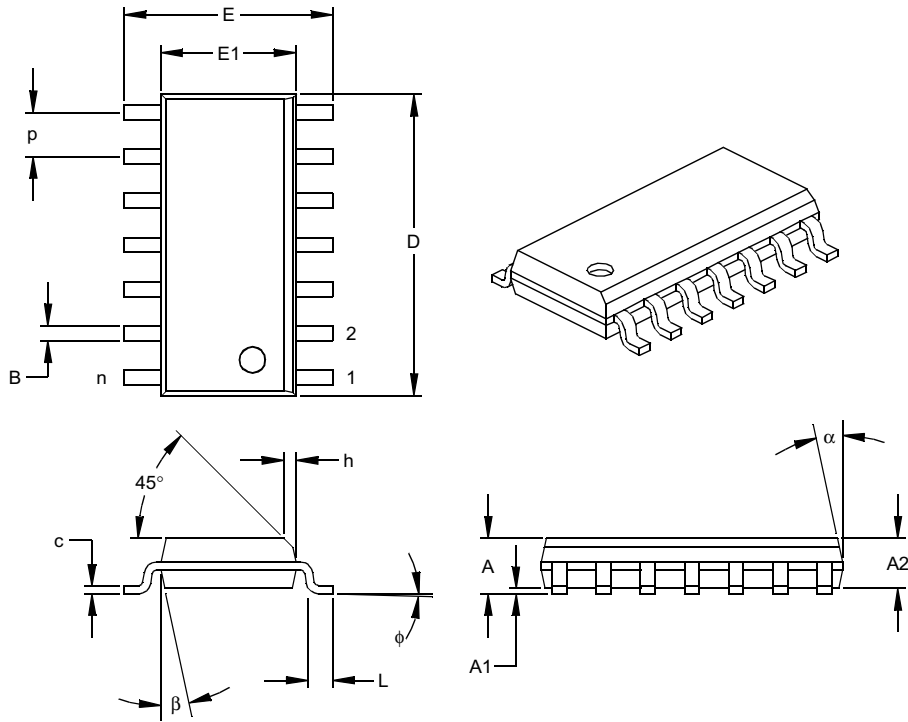

Units		INCHES*			MILLIMETERS		
Dimension Limits		MIN	NOM	MAX	MIN	NOM	MAX
Number of Pins	n		14			14	
Pitch	p		.050			1.27	
Overall Height	A	.053	.061	.069	1.35	1.55	1.75
Molded Package Thickness	A2	.052	.056	.061	1.32	1.42	1.55
Standoff §	A1	.004	.007	.010	0.10	0.18	0.25
Overall Width	E	.228	.236	.244	5.79	5.99	6.20
Molded Package Width	E1	.150	.154	.157	3.81	3.90	3.99
Overall Length	D	.337	.342	.347	8.56	8.69	8.81
Chamfer Distance	h	.010	.015	.020	0.25	0.38	0.51
Foot Length	L	.016	.033	.050	0.41	0.84	1.27
Foot Angle	φ	0	4	8	0	4	8
Lead Thickness	c	.008	.009	.010	0.20	0.23	0.25
Lead Width	B	.014	.017	.020	0.36	0.42	0.51
Mold Draft Angle Top	α	0	12	15	0	12	15
Mold Draft Angle Bottom	β	0	12	15	0	12	15

\* Controlling Parameter

§ Significant Characteristic

Notes:

Dimensions D and E1 do not include mold flash or protrusions. Mold flash or protrusions shall not exceed .010" (0.254mm) per side.

JEDEC Equivalent: MS-012

Drawing No. C04-065

# MCP616/617/618/619

## 14-Lead Plastic Thin Shrink Small Outline (ST) – 4.4 mm (TSSOP)

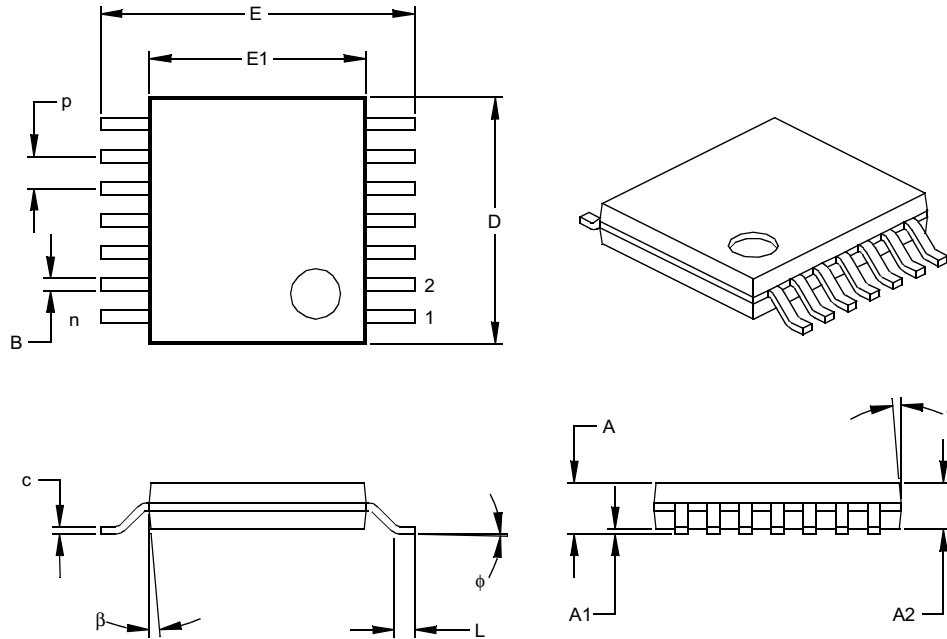

Dimension Limits	Units	INCHES			MILLIMETERS*		
		MIN	NOM	MAX	MIN	NOM	MAX
Number of Pins	n		14			14	
Pitch	p		.026			0.65	
Overall Height	A			.043			1.10
Molded Package Thickness	A2	.033	.035	.037	0.85	0.90	0.95
Standoff §	A1	.002	.004	.006	0.05	0.10	0.15
Overall Width	E	.246	.251	.256	6.25	6.38	6.50
Molded Package Width	E1	.169	.173	.177	4.30	4.40	4.50
Molded Package Length	D	.193	.197	.201	4.90	5.00	5.10
Foot Length	L	.020	.024	.028	0.50	0.60	0.70
Foot Angle	φ	0	4	8	0	4	8
Lead Thickness	c	.004	.006	.008	0.09	0.15	0.20
Lead Width	B1	.007	.010	.012	0.19	0.25	0.30
Mold Draft Angle Top	α	0	5	10	0	5	10
Mold Draft Angle Bottom	β	0	5	10	0	5	10

\* Controlling Parameter

§ Significant Characteristic

Notes:

Dimensions D and E1 do not include mold flash or protrusions. Mold flash or protrusions shall not exceed .005" (0.127mm) per side.

JEDEC Equivalent: MO-153

Drawing No. C04-087

# MCP616/617/618/619

---

---

NOTES:

## ON-LINE SUPPORT

Microchip provides on-line support on the Microchip World Wide Web (WWW) site.

The web site is used by Microchip as a means to make files and information easily available to customers. To view the site, the user must have access to the Internet and a web browser, such as Netscape or Microsoft Explorer. Files are also available for FTP download from our FTP site.

### Connecting to the Microchip Internet Web Site

The Microchip web site is available by using your favorite Internet browser to attach to:

**[www.microchip.com](http://www.microchip.com)**

The file transfer site is available by using an FTP service to connect to:

**<ftp://ftp.microchip.com>**

The web site and file transfer site provide a variety of services. Users may download files for the latest Development Tools, Data Sheets, Application Notes, User's Guides, Articles and Sample Programs. A variety of Microchip specific business information is also available, including listings of Microchip sales offices, distributors and factory representatives. Other data available for consideration is:

- Latest Microchip Press Releases
- Technical Support Section with Frequently Asked Questions
- Design Tips
- Device Errata
- Job Postings
- Microchip Consultant Program Member Listing
- Links to other useful web sites related to Microchip Products
- Conferences for products, Development Systems, technical information and more
- Listing of seminars and events

## Systems Information and Upgrade Hot Line

The Systems Information and Upgrade Line provides system users a listing of the latest versions of all of Microchip's development systems software products. Plus, this line provides information on how customers can receive any currently available upgrade kits. The Hot Line Numbers are:

1-800-755-2345 for U.S. and most of Canada, and

1-480-792-7302 for the rest of the world.

013001

# MCP616/617/618/619

---

---

## READER RESPONSE

It is our intention to provide you with the best documentation possible to ensure successful use of your Microchip product. If you wish to provide your comments on organization, clarity, subject matter, and ways in which our documentation can better serve you, please FAX your comments to the Technical Publications Manager at (480) 792-4150.

Please list the following information, and use this outline to provide us with your comments about this Data Sheet.

To: Technical Publications Manager Total Pages Sent  
RE: Reader Response  
From: Name \_\_\_\_\_  
Company \_\_\_\_\_  
Address \_\_\_\_\_  
City / State / ZIP / Country \_\_\_\_\_  
Telephone: (\_\_\_\_\_) \_\_\_\_\_ - \_\_\_\_\_ FAX: (\_\_\_\_\_) \_\_\_\_\_ - \_\_\_\_\_

Application (optional):

Would you like a reply? \_\_\_Y \_\_\_N

Device: **MCP616/617/618/619** Literature Number: **DS21613A**

Questions:

1. What are the best features of this document?

---

---

2. How does this document meet your hardware and software development needs?

---

---

3. Do you find the organization of this data sheet easy to follow? If not, why?

---

---

4. What additions to the data sheet do you think would enhance the structure and subject?

---

---

5. What deletions from the data sheet could be made without affecting the overall usefulness?

---

---

6. Is there any incorrect or misleading information (what and where)?

---

---

7. How would you improve this document?

---

---

8. How would you improve our software, systems, and silicon products?

---

---

# MCP616/617/618/619

## PRODUCT IDENTIFICATION SYSTEM

To order or obtain information, e.g., on pricing or delivery, refer to the factory or the listed sales office.

<u>PART NO.</u>	<u>X</u>	<u>/XX</u>
Device	Temperature Range	Package
Device	MCP616 = Single Operational Amplifier MCP616T = Single Operational Amplifier (Tape and Reel-SOIC/MSOP) MCP617 = Dual Operational Amplifier MCP617T = Dual Operational Amplifier (Tape and Reel-SOIC/MSOP) MCP618 = Single Operational Amplifier w/ <u>CS</u> Function MCP618T = Single Operational Amplifier w/ <u>CS</u> Function (Tape and Reel-SOIC/MSOP) MCP619 = Quad Operational Amplifier MCP619T = Quad Operational Amplifier (Tape and Reel-SOIC/TSSOP)	
Temperature Range	I = -40°C to +85°C	
Package	P = Plastic DIP (300 mil Body), 8-lead & 14-lead SN = Plastic SOIC (150 mil Body), 8-lead SL = Plastic SOIC (150 mil Body), 14-lead ST = Plastic TSSOP, 14-lead MS = Plastic MSOP, 8-lead	

**Examples:**

- a) MCP616-I/P Industrial Temp., PDIP package
- b) MCP616-I/SN Industrial Temp., SOIC package
- c) MCP616T-I/SN Tape and Reel, Industrial Temp., SOIC package
- d) MCP616-I/MS Industrial Temp., MSOP package
- e) MCP616T-I/MS Tape and Reel, Industrial Temp., MSOP package
- f) MCP617-I/P Industrial Temp., PDIP package
- g) MCP618-I/SN Industrial Temp., SOIC package
- h) MCP618T-I/SN Tape and Reel, Industrial Temp., SOIC package
- i) MCP619-I/P Industrial Temp., PDIP package

## Sales and Support

### Data Sheets

Products supported by a preliminary Data Sheet may have an errata sheet describing minor operational differences and recommended workarounds. To determine if an errata sheet exists for a particular device, please contact one of the following:

1. Your local Microchip sales office
2. The Microchip Corporate Literature Center U.S. FAX: (480) 792-7277
3. The Microchip Worldwide Site ([www.microchip.com](http://www.microchip.com))

Please specify which device, revision of silicon and Data Sheet (include Literature #) you are using.

### New Customer Notification System

Register on our web site ([www.microchip.com/cn](http://www.microchip.com/cn)) to receive the most current information on our products.

# MCP616/617/618/619

---

---

NOTES:



NOTES:

# MCP616/617/618/619

---

---

NOTES:

"All rights reserved. Copyright © 2001, Microchip Technology Incorporated, USA. Information contained in this publication regarding device applications and the like is intended through suggestion only and may be superseded by updates. No representation or warranty is given and no liability is assumed by Microchip Technology Incorporated with respect to the accuracy or use of such information, or infringement of patents or other intellectual property rights arising from such use or otherwise. Use of Microchip's products as critical components in life support systems is not authorized except with express written approval by Microchip. No licenses are conveyed, implicitly or otherwise, under any intellectual property rights. The Microchip logo and name are registered trademarks of Microchip Technology Inc. in the U.S.A. and other countries. All rights reserved. All other trademarks mentioned herein are the property of their respective companies. No licenses are conveyed, implicitly or otherwise, under any intellectual property rights."

#### Trademarks

The Microchip name, logo, PIC, PICmicro, PICMASTER, PICSTART, PRO MATE, KEELoQ, SEEVAL, MPLAB and The Embedded Control Solutions Company are registered trademarks of Microchip Technology Incorporated in the U.S.A. and other countries.

Total Endurance, ICSP, In-Circuit Serial Programming, Filter-Lab, MXDEV, microID, FlexROM, fuzzyLAB, MPASM, MPLINK, MPLIB, PICDEM, ICEPIC, Migratable Memory, FanSense, ECONOMONITOR, SelectMode and microPort are trademarks of Microchip Technology Incorporated in the U.S.A.

Serialized Quick Term Programming (SQTP) is a service mark of Microchip Technology Incorporated in the U.S.A.

All other trademarks mentioned herein are property of their respective companies.

© 2001, Microchip Technology Incorporated, Printed in the U.S.A., All Rights Reserved.

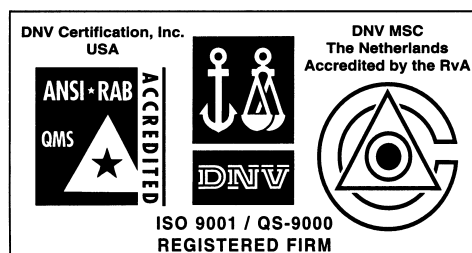

Microchip received QS-9000 quality system certification for its worldwide headquarters, design and wafer fabrication facilities in Chandler and Tempe, Arizona in July 1999. The Company's quality system processes and procedures are QS-9000 compliant for its PICmicro® 8-bit MCUs, KEELoQ® code hopping devices, Serial EEPROMs and microperipheral products. In addition, Microchip's quality system for the design and manufacture of development systems is ISO 9001 certified.



# MICROCHIP

## WORLDWIDE SALES AND SERVICE

### AMERICAS

#### Corporate Office

2355 West Chandler Blvd.  
Chandler, AZ 85224-6199  
Tel: 480-792-7200 Fax: 480-792-7277  
Technical Support: 480-792-7627  
Web Address: <http://www.microchip.com>

#### Rocky Mountain

2355 West Chandler Blvd.  
Chandler, AZ 85224-6199  
Tel: 480-792-7966 Fax: 480-792-7456

#### Atlanta

500 Sugar Mill Road, Suite 200B  
Atlanta, GA 30350  
Tel: 770-640-0034 Fax: 770-640-0307

#### Austin

Analog Product Sales  
8303 MoPac Expressway North  
Suite A-201  
Austin, TX 78759  
Tel: 512-345-2030 Fax: 512-345-6085

#### Boston

2 Lan Drive, Suite 120  
Westford, MA 01886  
Tel: 978-692-3848 Fax: 978-692-3821

#### Boston

Analog Product Sales  
Unit A-8-1 Millbrook Tarry Condominium  
97 Lowell Road  
Concord, MA 01742  
Tel: 978-371-6400 Fax: 978-371-0050

#### Chicago

333 Pierce Road, Suite 180  
Itasca, IL 60143  
Tel: 630-285-0071 Fax: 630-285-0075

#### Dallas

4570 Westgrove Drive, Suite 160  
Addison, TX 75001  
Tel: 972-818-7423 Fax: 972-818-2924

#### Dayton

Two Prestige Place, Suite 130  
Miamisburg, OH 45342  
Tel: 937-291-1654 Fax: 937-291-9175

#### Detroit

Tri-Atria Office Building  
32255 Northwestern Highway, Suite 190  
Farmington Hills, MI 48334  
Tel: 248-538-2250 Fax: 248-538-2260

#### Los Angeles

18201 Von Karman, Suite 1090  
Irvine, CA 92612  
Tel: 949-263-1888 Fax: 949-263-1338

#### Mountain View

Analog Product Sales  
1300 Terra Bella Avenue  
Mountain View, CA 94043-1836  
Tel: 650-968-9241 Fax: 650-967-1590

#### New York

150 Motor Parkway, Suite 202  
Hauppauge, NY 11788  
Tel: 631-273-5305 Fax: 631-273-5335

#### San Jose

Microchip Technology Inc.  
2107 North First Street, Suite 590  
San Jose, CA 95131  
Tel: 408-436-7950 Fax: 408-436-7955

#### Toronto

6285 Northam Drive, Suite 108  
Mississauga, Ontario L4V 1X5, Canada  
Tel: 905-673-0699 Fax: 905-673-6509

### ASIA/PACIFIC

#### Australia

Microchip Technology Australia Pty Ltd  
Suite 22, 41 Rawson Street  
Epping 2121, NSW  
Australia  
Tel: 61-2-9868-6733 Fax: 61-2-9868-6755

#### China - Beijing

Microchip Technology Beijing Office  
Unit 915  
New China Hong Kong Manhattan Bldg.  
No. 6 Chaoyangmen Beidajie  
Beijing, 100027, No. China  
Tel: 86-10-85282100 Fax: 86-10-85282104

#### China - Shanghai

Microchip Technology Shanghai Office  
Room 701, Bldg. B  
Far East International Plaza  
No. 317 Xian Xia Road  
Shanghai, 200051  
Tel: 86-21-6275-5700 Fax: 86-21-6275-5060

#### Hong Kong

Microchip Asia Pacific  
RM 2101, Tower 2, Metroplaza  
223 Hing Fong Road  
Kwai Fong, N.T., Hong Kong  
Tel: 852-2401-1200 Fax: 852-2401-3431

#### India

Microchip Technology Inc.  
India Liaison Office  
Divyasree Chambers  
1 Floor, Wing A (A3/A4)  
No. 11, O'Shaughnessey Road  
Bangalore, 560 025, India  
Tel: 91-80-2290061 Fax: 91-80-2290062

#### Japan

Microchip Technology Intl. Inc.  
Benex S-1 6F  
3-18-20, Shinyokohama  
Kohoku-Ku, Yokohama-shi  
Kanagawa, 222-0033, Japan  
Tel: 81-45-471-6166 Fax: 81-45-471-6122

### ASIA/PACIFIC (continued)

#### Korea

Microchip Technology Korea  
168-1, Youngbo Bldg. 3 Floor  
Samsung-Dong, Kangnam-Ku  
Seoul, Korea  
Tel: 82-2-554-7200 Fax: 82-2-558-5934

#### Singapore

Microchip Technology Singapore Pte Ltd.  
200 Middle Road  
#07-02 Prime Centre  
Singapore, 188980  
Tel: 65-334-8870 Fax: 65-334-8850

#### Taiwan

Microchip Technology Taiwan  
11F-3, No. 207  
Tung Hua North Road  
Taipei, 105, Taiwan  
Tel: 886-2-2717-7175 Fax: 886-2-2545-0139

#### EUROPE

#### Denmark

Microchip Technology Denmark ApS  
Regus Business Centre  
Lautrup høj 1-3  
Ballerup DK-2750 Denmark  
Tel: 45 4420 9895 Fax: 45 4420 9910

#### France

Arizona Microchip Technology SARL  
Parc d'Activite du Moulin de Massy  
43 Rue du Saule Trapu  
Batiment A - 1er Etage  
91300 Massy, France  
Tel: 33-1-69-53-63-20 Fax: 33-1-69-30-90-79

#### Germany

Arizona Microchip Technology GmbH  
Gustav-Heinemann Ring 125  
D-81739 Munich, Germany  
Tel: 49-89-627-144 0 Fax: 49-89-627-144-44

#### Germany

Analog Product Sales  
Lochamer Strasse 13  
D-82152 Martinsried, Germany  
Tel: 49-89-895650-0 Fax: 49-89-895650-22

#### Italy

Arizona Microchip Technology SRL  
Centro Direzionale Colleoni  
Palazzo Taurus 1 V. Le Colleoni 1  
20041 Agrate Brianza  
Milan, Italy  
Tel: 39-039-65791-1 Fax: 39-039-6899883

#### United Kingdom

Arizona Microchip Technology Ltd.  
505 Eskdale Road  
Winnersh Triangle  
Wokingham  
Berkshire, England RG41 5TU  
Tel: 44 118 921 5869 Fax: 44-118 921-5820

01/30/01

All rights reserved. © 2001 Microchip Technology Incorporated. Printed in the USA. 3/01 Printed on recycled paper.

Information contained in this publication regarding device applications and the like is intended through suggestion only and may be superseded by updates. It is your responsibility to ensure that your application meets with your specifications. No representation or warranty is given and no liability is assumed by Microchip Technology Incorporated with respect to the accuracy or use of such information, or infringement of patents or other intellectual property rights arising from such use or otherwise. Use of Microchip's products as critical components in life support systems is not authorized except with express written approval by Microchip. No licenses are conveyed, implicitly or otherwise, except as maybe explicitly expressed herein, under any intellectual property rights. The Microchip logo and name are registered trademarks of Microchip Technology Inc. in the U.S.A. and other countries. All rights reserved. All other trademarks mentioned herein are the property of their respective companies.