



# MCP601/2/3/4

## 2.7V to 5.5V Single Supply CMOS Op Amps

### FEATURES

- Single Supply: 2.7V to 5.5V
- Rail-to-Rail Output
- Input Range Includes Ground
- Gain Bandwidth Product: 2.8 MHz (typ.)
- Unity Gain Stable
- Low Quiescent Current: 230  $\mu$ A/amplifier (typ.)
- Chip Select: MCP603
- Temperature Ranges:
  - Industrial: -40°C to +85°C
  - Extended: -40°C to +125°C
- Available in Single, Dual and Quad

### TYPICAL APPLICATIONS

- Portable Equipment
- A/D Converter Driver
- Photo Diode Pre-amp
- Analog Filters
- Data Acquisition
- Notebooks and PDAs
- Sensor Interface

### AVAILABLE TOOLS

- SPICE Macro Models at [www.microchip.com](http://www.microchip.com)
- FilterLab<sup>®</sup> Software at [www.microchip.com](http://www.microchip.com)

### DESCRIPTION

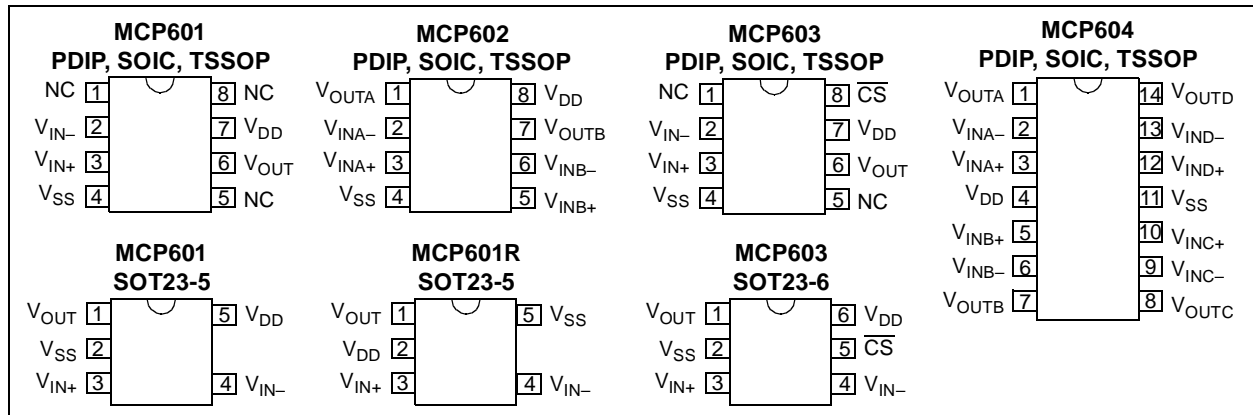
The Microchip Technology Inc. MCP601/2/3/4 family of low-power op amps (operational amplifiers) are offered in single (MCP601), single with Chip Select (MCP603), dual (MCP602) and quad (MCP604) configurations. These op amps utilize an advanced CMOS technology, which provides low bias current, high-speed operation, high open-loop gain, and rail-to-rail output swing. This product offering operates with a single supply voltage that can be as low as 2.7V, while drawing 230  $\mu$ A (typ.) of quiescent current per amplifier. In addition, the common mode input voltage range goes 0.3V below ground, making these amplifiers ideal for single supply operation.

These devices are appropriate for low-power, battery-operated circuits due to the low quiescent current, for A/D convert driver amplifiers because of their wide bandwidth or for anti-aliasing filters by virtue of their low input bias current.

The MCP601, MCP602 and MCP603 are available in standard 8-lead PDIP, SOIC and TSSOP packages. The MCP601 and MCP601R are also available in a standard 5-lead SOT23 package and the MCP603 in a standard 6-lead SOT23 package. The MCP604 is offered in standard 14-lead PDIP, SOIC and TSSOP packages.

The MCP601/2/3/4 family is available in the Industrial and Extended temperature ranges and also has a power supply range of 2.7V to 5.5V.

### PACKAGE TYPES



# MCP601/2/3/4

## 1.0 ELECTRICAL CHARACTERISTICS

### Absolute Maximum Ratings †

$V_{DD} - V_{SS}$ .....	7.0V
All inputs and outputs .....	$V_{SS} - 0.3V$ to $V_{DD} + 0.3V$
Difference Input voltage .....	$ V_{DD} - V_{SS} $
Output Short Circuit Current .....	continuous
Current at Input Pin .....	$\pm 2$ mA
Current at Output and Supply Pins .....	$\pm 30$ mA
Storage temperature .....	$-65^{\circ}\text{C}$ to $+150^{\circ}\text{C}$
Junction temperature .....	$+150^{\circ}\text{C}$
ESD protection on all pins (HBM; MM) .....	$\geq 3$ kV; 200V

† **Notice:** Stresses above those listed under "Maximum Ratings" may cause permanent damage to the device. This is a stress rating only and functional operation of the device at those or any other conditions above those indicated in the operational listings of this specification is not implied. Exposure to maximum rating conditions for extended periods may affect device reliability.

### DC CHARACTERISTICS

Electrical Specifications: Unless otherwise specified, $T_A = +25^{\circ}\text{C}$ , $V_{DD} = +2.7V$ to $+5.5V$ , $V_{SS} = \text{GND}$ , $V_{CM} = V_{DD}/2$ , $V_{OUT} \approx V_{DD}/2$ , and $R_L = 100$ k $\Omega$ to $V_{DD}/2$ .						
Parameters	Sym	Min	Typ	Max	Units	Conditions
<b>Input Offset</b>						
Input Offset Voltage	$V_{OS}$	-2	$\pm 0.7$	+2	mV	
Industrial Temperature	$V_{OS}$	-3	$\pm 1$	+3	mV	$T_A = -40^{\circ}\text{C}$ to $+85^{\circ}\text{C}$ (Note 1)
Extended Temperature	$V_{OS}$	-4.5	$\pm 1$	+4.5	mV	$T_A = -40^{\circ}\text{C}$ to $+125^{\circ}\text{C}$ (Note 1)
Input Offset Temperature Drift	$\Delta V_{OS}/\Delta T_A$	—	$\pm 2.5$	—	$\mu\text{V}/^{\circ}\text{C}$	$T_A = -40^{\circ}\text{C}$ to $+125^{\circ}\text{C}$
Power Supply Rejection	PSRR	80	88	—	dB	$V_{DD} = 2.7V$ to $5.5V$
<b>Input Current and Impedance</b>						
Input Bias Current	$I_B$	—	1	—	pA	
Industrial Temperature	$I_B$	—	20	60	pA	$T_A = +85^{\circ}\text{C}$ (Note 2)
Extended Temperature	$I_B$	—	450	5000	pA	$T_A = +125^{\circ}\text{C}$ (Note 2)
Input Offset Current	$I_{OS}$	—	$\pm 1$	—	pA	
Common Mode Input Impedance	$Z_{CM}$	—	$10^{13}  6$	—	$\Omega  \text{pF}$	
Differential Input Impedance	$Z_{DIFF}$	—	$10^{13}  3$	—	$\Omega  \text{pF}$	
<b>Common Mode</b>						
Common Mode Input Range	$V_{CMR}$	$V_{SS}-0.3$	—	$V_{DD}-1.2$	V	
Common Mode Rejection Ratio	CMRR	75	90	—	dB	$V_{DD} = 5.0V$ , $V_{CM} = -0.3V$ to $3.8V$
<b>Open-loop Gain</b>						
DC Open-loop Gain (large signal)	$A_{OL}$	100	115	—	dB	$R_L = 25$ k $\Omega$ to $V_{DD}/2$ , $V_{OUT} = 100$ mV to $V_{DD} - 100$ mV
	$A_{OL}$	95	110	—	dB	$R_L = 5$ k $\Omega$ to $V_{DD}/2$ , $V_{OUT} = 100$ mV to $V_{DD} - 100$ mV
<b>Output</b>						
Maximum Output Voltage Swing	$V_{OL}, V_{OH}$	$V_{SS}+15$	—	$V_{DD}-20$	mV	$R_L = 25$ k $\Omega$ to $V_{DD}/2$ , Output overdrive = $0.5V$
	$V_{OL}, V_{OH}$	$V_{SS}+45$	—	$V_{DD}-60$	mV	$R_L = 5$ k $\Omega$ to $V_{DD}/2$ , Output overdrive = $0.5V$
Linear Output Voltage Swing	$V_{OUT}$	$V_{SS}+100$	—	$V_{DD}-100$	mV	$R_L = 25$ k $\Omega$ to $V_{DD}/2$ , $A_{OL} \geq 100$ dB
	$V_{OUT}$	$V_{SS}+100$	—	$V_{DD}-100$	mV	$R_L = 5$ k $\Omega$ to $V_{DD}/2$ , $A_{OL} \geq 95$ dB
Output Short Circuit Current	$I_{SC}$	—	$\pm 22$	—	mA	$V_{DD} = 5.5V$
	$I_{SC}$	—	$\pm 12$	—	mA	$V_{DD} = 2.7V$
<b>Power Supply</b>						
Supply Voltage	$V_{DD}$	2.7	—	5.5	V	
Quiescent Current per Amplifier	$I_Q$	—	230	325	$\mu\text{A}$	$I_O = 0$

**Note 1:** Maximum and minimum specified for PDIP and SOIC packages only. Typical specs refer to all packages.

**Note 2:** Maximum and minimum specified for PDIP, SOIC and TSSOP packages only. Typical specs refer to all packages.

### PIN FUNCTION TABLE

Name	Function
$V_{IN+}, V_{INA+}, V_{INB+}, V_{INC+}, V_{IND+}$	Non-inverting Inputs
$V_{IN-}, V_{INA-}, V_{INB-}, V_{INC-}, V_{IND-}$	Inverting Inputs
$V_{DD}$	Positive Power Supply
$V_{SS}$	Negative Power Supply
$V_{OUT}, V_{OUTA}, V_{OUTB}, V_{OUTC}, V_{OUTD}$	Outputs
$\overline{CS}$	Chip Select
NC	No Internal Connection

## AC CHARACTERISTICS

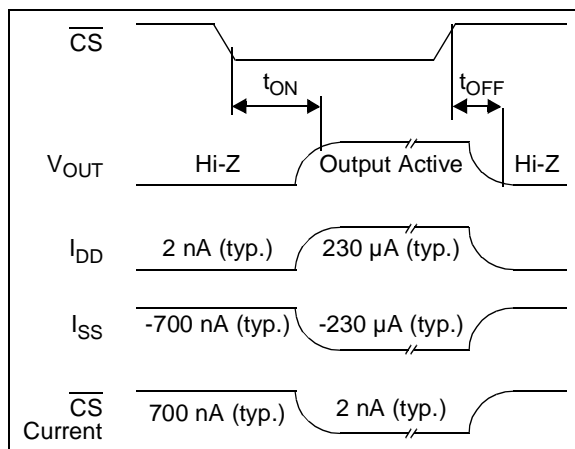
**Electrical Specifications:** Unless otherwise indicated,  $T_A = +25^\circ\text{C}$ ,  $V_{DD} = +2.7\text{V}$  to  $+5.5\text{V}$ ,  $V_{SS} = \text{GND}$ ,  $V_{CM} = V_{DD}/2$ ,  $V_{OUT} \approx V_{DD}/2$ ,  $R_L = 100\text{ k}\Omega$  to  $V_{DD}/2$ , and  $C_L = 50\text{ pF}$ .

Parameters	Sym	Min	Typ	Max	Units	Conditions
<b>Frequency Response</b>						
Gain Bandwidth Product	GBWP	—	2.8	—	MHz	
Phase Margin	PM	—	50	—	°	$G = +1\text{ V/V}$
<b>Step Response</b>						
Slew Rate	SR	—	2.3	—	$\text{V}/\mu\text{s}$	$G = +1\text{ V/V}$
Settling Time (0.01%)	$t_{\text{settle}}$	—	4.5	—	$\mu\text{s}$	$G = +1\text{ V/V}$ , 3.8V step
<b>Noise</b>						
Input Noise Voltage	$E_{ni}$	—	7	—	$\mu\text{V}_{\text{P-P}}$	$f = 0.1\text{ Hz}$ to $10\text{ Hz}$
Input Noise Voltage Density	$e_{ni}$	—	29	—	$\text{nV}/\sqrt{\text{Hz}}$	$f = 1\text{ kHz}$
	$e_{ni}$	—	21	—	$\text{nV}/\sqrt{\text{Hz}}$	$f = 10\text{ kHz}$
Input Noise Current Density	$i_{ni}$	—	0.6	—	$\text{fA}/\sqrt{\text{Hz}}$	$f = 1\text{ kHz}$

## MCP603 CHIP SELECT CHARACTERISTICS

**Electrical Specifications:** Unless otherwise indicated,  $T_A = +25^\circ\text{C}$ ,  $V_{DD} = +2.7\text{V}$  to  $+5.5\text{V}$ ,  $V_{SS} = \text{GND}$ ,  $V_{CM} = V_{DD}/2$ ,  $V_{OUT} \approx V_{DD}/2$ ,  $R_L = 100\text{ k}\Omega$  to  $V_{DD}/2$ , and  $C_L = 50\text{ pF}$ .

Parameters	Sym	Min	Typ	Max	Units	Conditions
<b>DC Characteristics</b>						
$\overline{\text{CS}}$ Logic Threshold, Low	$V_{IL}$	$V_{SS}$	—	$0.2 V_{DD}$	V	
$\overline{\text{CS}}$ Input Current, Low	$I_{CSL}$	-1.0	—	—	$\mu\text{A}$	$\overline{\text{CS}} = 0.2V_{DD}$
$\overline{\text{CS}}$ Logic Threshold, High	$V_{IH}$	$0.8 V_{DD}$	—	$V_{DD}$	V	
$\overline{\text{CS}}$ Input Current, High	$I_{CSH}$	—	0.7	2.0	$\mu\text{A}$	$\overline{\text{CS}} = V_{DD}$
Shutdown $V_{SS}$ current	$I_{Q\_SHDN}$	-2.0	-0.7	—	$\mu\text{A}$	$\overline{\text{CS}} = V_{DD}$
Amplifier Output Leakage in Shutdown	$I_{O\_SHDN}$	—	1	—	nA	
$\overline{\text{CS}}$ Threshold Hysteresis	HYST	—	0.3	—	V	Internal switch
<b>Timing</b>						
$\overline{\text{CS}}$ Low to Amplifier Output Turn-on Time	$t_{ON}$	—	3.1	10	$\mu\text{s}$	$\overline{\text{CS}} \leq 0.2V_{DD}$ , $G = +1\text{ V/V}$
$\overline{\text{CS}}$ High to Amplifier Output High-Z Time	$t_{OFF}$	—	100	—	ns	$\overline{\text{CS}} \geq 0.8V_{DD}$ , $G = +1\text{ V/V}$ , No Load



**FIGURE 1-1:** MCP603 Chip Select ( $\overline{\text{CS}}$ ) timing diagram.

# MCP601/2/3/4

## TEMPERATURE CHARACTERISTICS

**Electrical Specifications:** Unless otherwise indicated,  $V_{DD} = +2.7V$  to  $+5.5V$  and  $V_{SS} = GND$ .

Parameters	Sym	Min	Typ	Max	Units	Conditions
------------	-----	-----	-----	-----	-------	------------

### Temperature Ranges

Specified Temperature Range	$T_A$	-40	—	+85	°C	Industrial temperature parts
	$T_A$	-40	—	+125	°C	Extended temperature parts
Operating Temperature Range	$T_A$	-40	—	+125	°C	<b>Note</b>
Storage Temperature Range	$T_A$	-65	—	+150	°C	

### Thermal Package Resistances

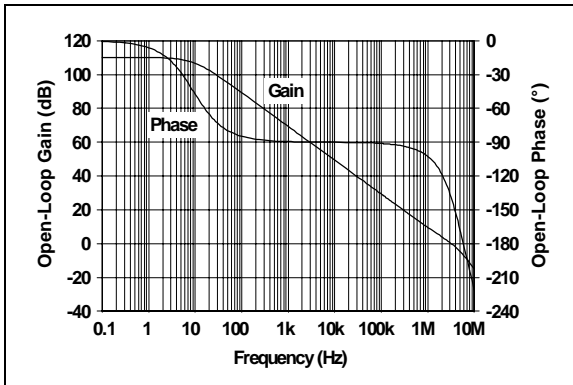
Thermal Resistance, 5L-SOT23	$\theta_{JA}$	—	256	—	°C/W	
Thermal Resistance, 6L-SOT23	$\theta_{JA}$	—	230	—	°C/W	
Thermal Resistance, 8L-PDIP	$\theta_{JA}$	—	85	—	°C/W	
Thermal Resistance, 8L-SOIC	$\theta_{JA}$	—	163	—	°C/W	
Thermal Resistance, 8L-TSSOP	$\theta_{JA}$	—	124	—	°C/W	
Thermal Resistance, 14L-PDIP	$\theta_{JA}$	—	70	—	°C/W	
Thermal Resistance, 14L-SOIC	$\theta_{JA}$	—	120	—	°C/W	
Thermal Resistance, 14L-TSSOP	$\theta_{JA}$	—	100	—	°C/W	

**Note:** The Industrial temperature parts operate over this extended range, but with reduced performance. The Extended temperature specs do not apply to Industrial temperature parts. In any case, the internal Junction temperature ( $T_J$ ) must not exceed the absolute maximum specification of 150°C.

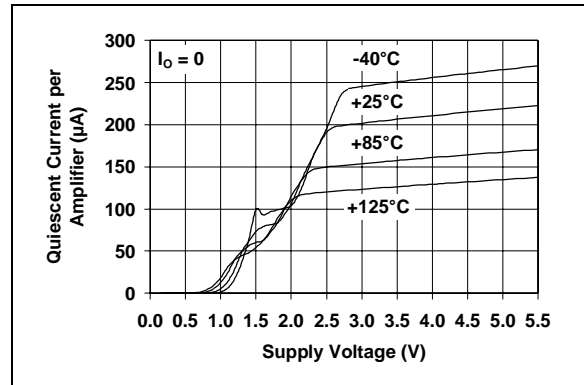
## 2.0 TYPICAL PERFORMANCE CURVES

**Note:** The graphs and tables provided following this note are a statistical summary based on a limited number of samples and are provided for informational purposes only. The performance characteristics listed herein are not tested or guaranteed. In some graphs or tables, the data presented may be outside the specified operating range (e.g., outside specified power supply range) and therefore outside the warranted range.

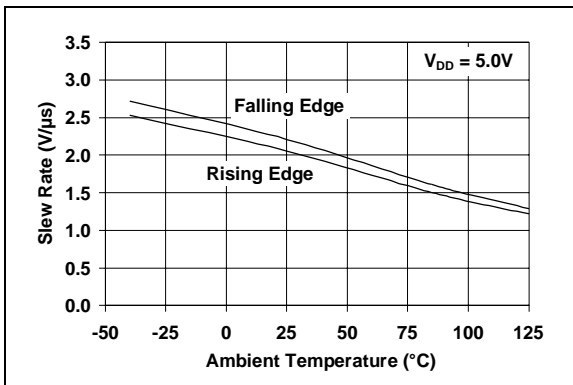
**Note:** Unless otherwise indicated,  $T_A = +25^\circ\text{C}$ ,  $V_{DD} = +2.7\text{V}$  to  $+5.5\text{V}$ ,  $V_{SS} = \text{GND}$ ,  $V_{CM} = V_{DD}/2$ ,  $R_L = 100\text{ k}\Omega$  to  $V_{DD}/2$ ,  $V_{OUT} \approx V_{DD}/2$ , and  $C_L = 50\text{ pF}$ .



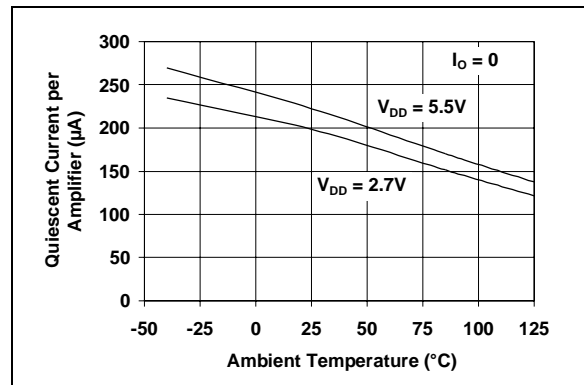
**FIGURE 2-1:** Open-Loop Gain, Phase vs. Frequency.



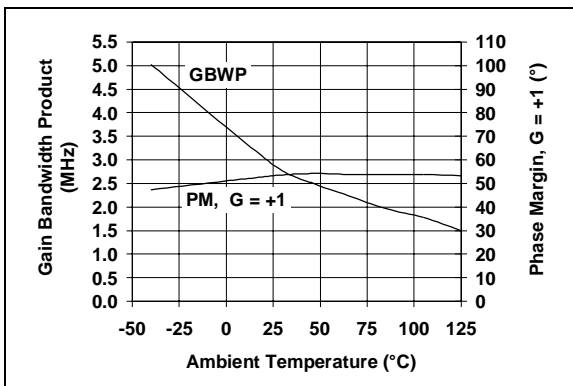
**FIGURE 2-4:** Quiescent Current vs. Supply Voltage.



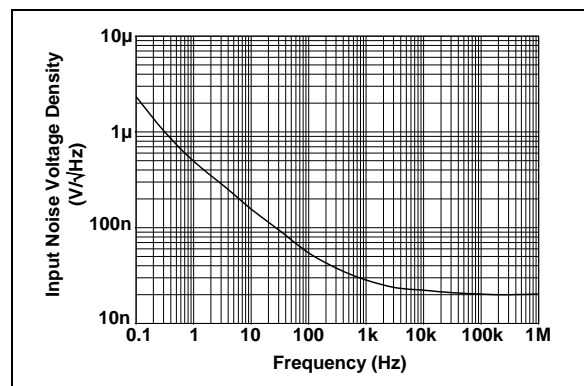
**FIGURE 2-2:** Slew Rate vs. Temperature.



**FIGURE 2-5:** Quiescent Current vs. Temperature.



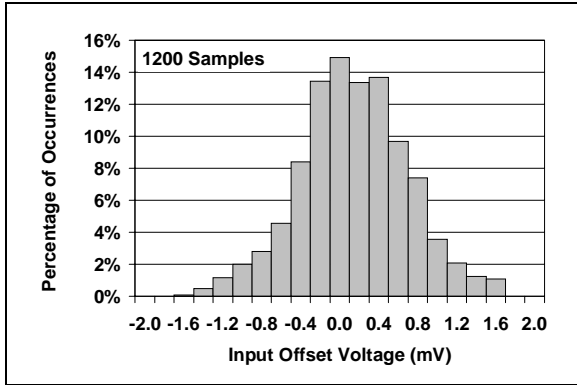
**FIGURE 2-3:** Gain Bandwidth Product, Phase Margin vs. Temperature.



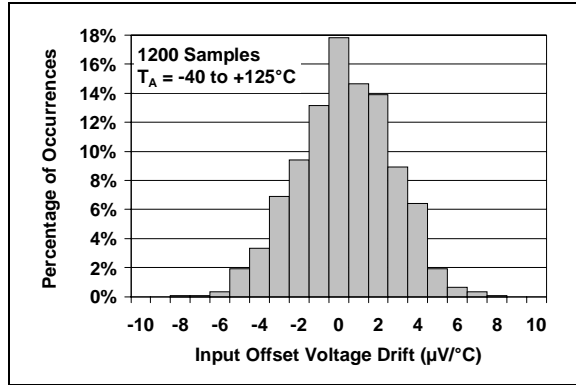
**FIGURE 2-6:** Input Noise Voltage Density vs. Frequency.

# MCP601/2/3/4

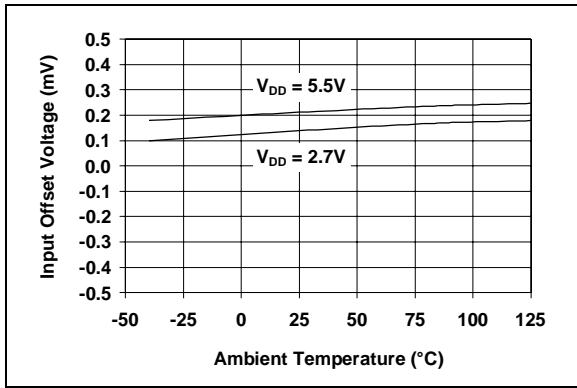
**Note:** Unless otherwise indicated,  $T_A = +25^\circ\text{C}$ ,  $V_{DD} = +2.7\text{V}$  to  $+5.5\text{V}$ ,  $V_{SS} = \text{GND}$ ,  $V_{CM} = V_{DD}/2$ ,  $R_L = 100\text{ k}\Omega$  to  $V_{DD}/2$ ,  $V_{OUT} \approx V_{DD}/2$ , and  $C_L = 50\text{ pF}$ .



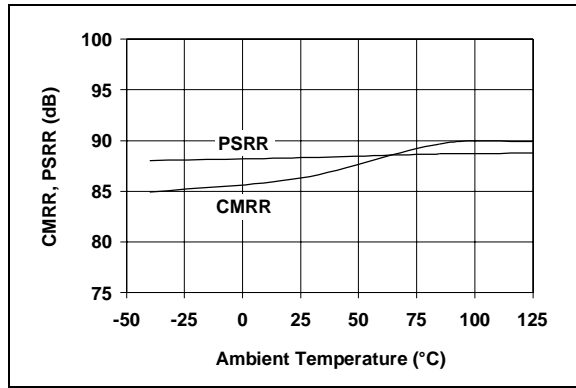
**FIGURE 2-7:** *Input Offset Voltage.*



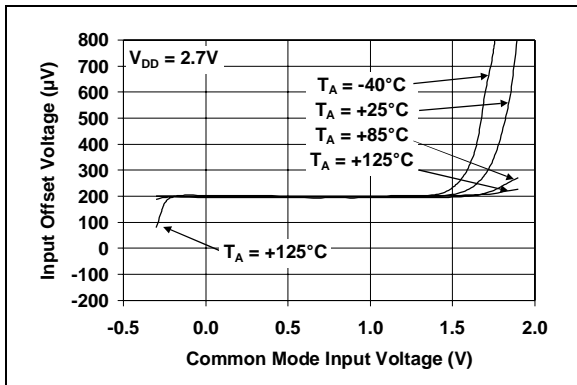
**FIGURE 2-10:** *Input Offset Voltage Drift.*



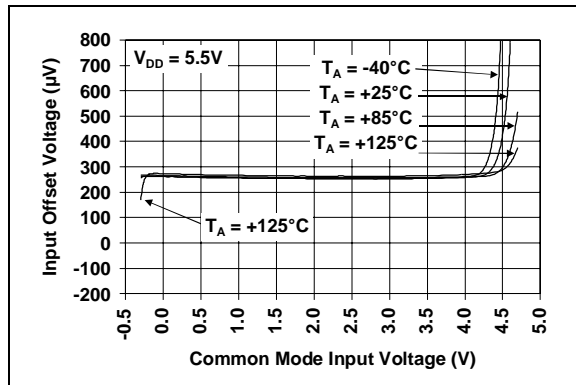
**FIGURE 2-8:** *Input Offset Voltage vs. Temperature.*



**FIGURE 2-11:** *CMRR, PSRR vs. Temperature.*

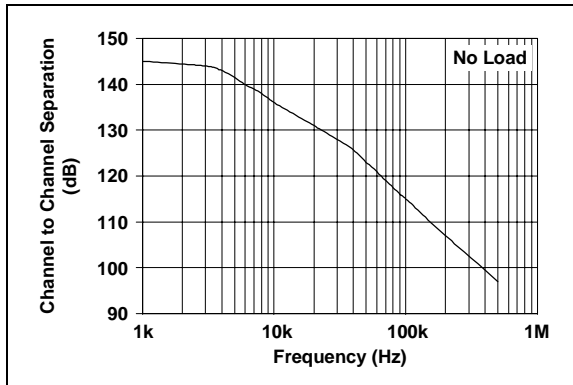


**FIGURE 2-9:** *Input Offset Voltage vs. Common Mode Input Voltage with  $V_{DD} = 2.7\text{V}$ .*

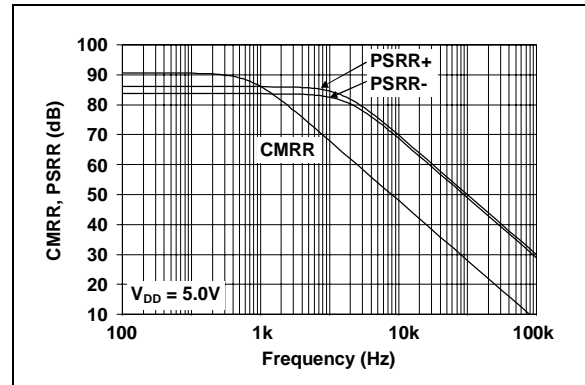


**FIGURE 2-12:** *Input Offset Voltage vs. Common Mode Input Voltage with  $V_{DD} = 5.5\text{V}$ .*

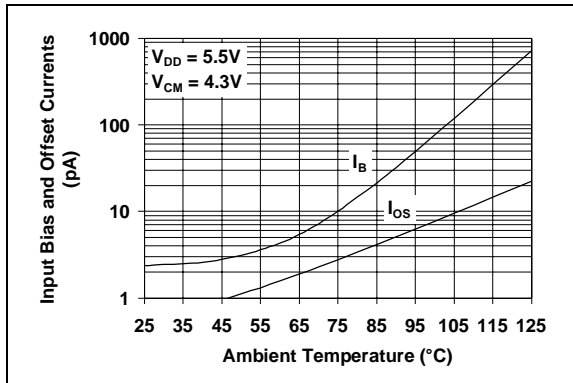
**Note:** Unless otherwise indicated,  $T_A = +25^\circ\text{C}$ ,  $V_{DD} = +2.7\text{V}$  to  $+5.5\text{V}$ ,  $V_{SS} = \text{GND}$ ,  $V_{CM} = V_{DD}/2$ ,  $R_L = 100\text{ k}\Omega$  to  $V_{DD}/2$ ,  $V_{OUT} \approx V_{DD}/2$ , and  $C_L = 50\text{ pF}$ .



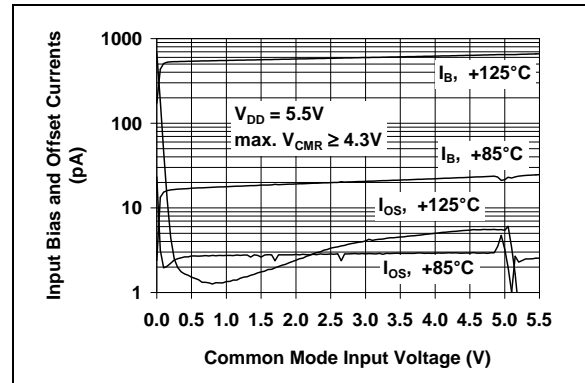
**FIGURE 2-13:** Channel-to-Channel Separation vs. Frequency.



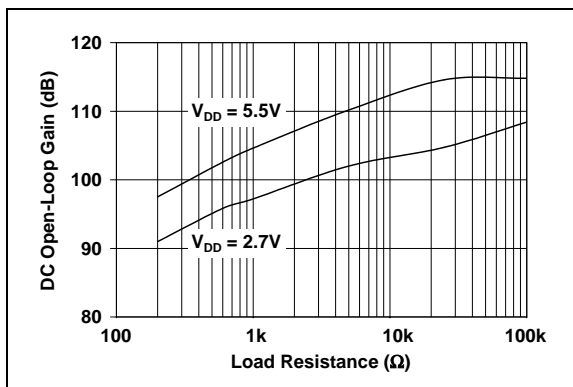
**FIGURE 2-16:** CMRR, PSRR vs. Frequency.



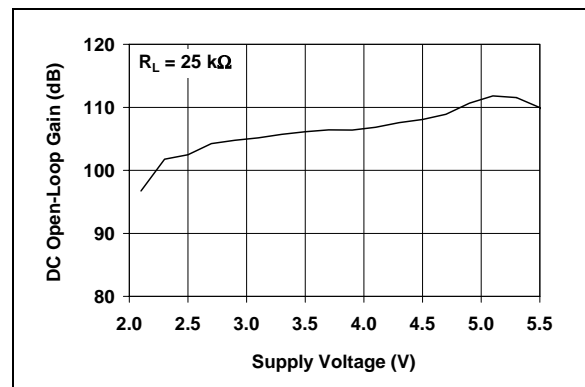
**FIGURE 2-14:** Input Bias Current, Input Offset Current vs. Ambient Temperature.



**FIGURE 2-17:** Input Bias Current, Input Offset Current vs. Common Mode Input Voltage.



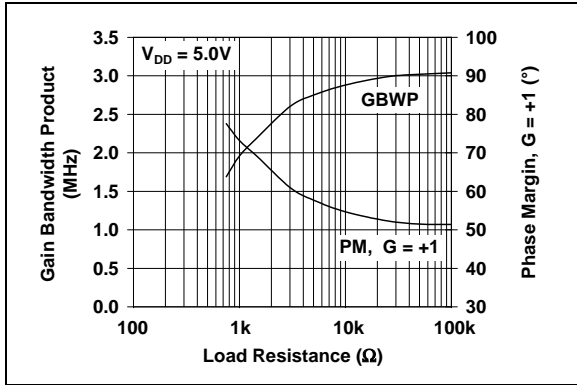
**FIGURE 2-15:** DC Open-Loop Gain vs. Load Resistance.



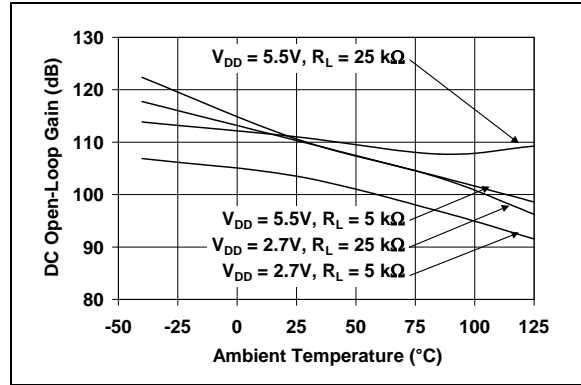
**FIGURE 2-18:** DC Open-Loop Gain vs. Supply Voltage.

# MCP601/2/3/4

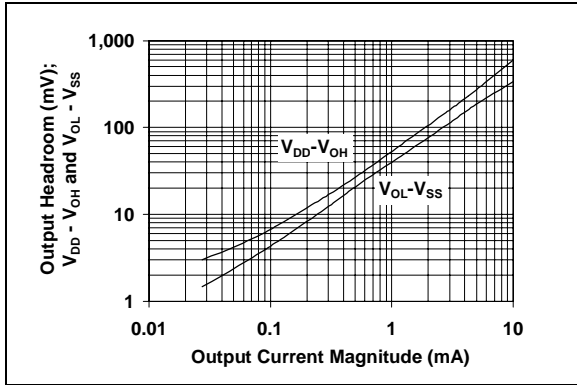
**Note:** Unless otherwise indicated,  $T_A = +25^\circ\text{C}$ ,  $V_{DD} = +2.7\text{V}$  to  $+5.5\text{V}$ ,  $V_{SS} = \text{GND}$ ,  $V_{CM} = V_{DD}/2$ ,  $R_L = 100\text{ k}\Omega$  to  $V_{DD}/2$ ,  $V_{OUT} \approx V_{DD}/2$ , and  $C_L = 50\text{ pF}$ .



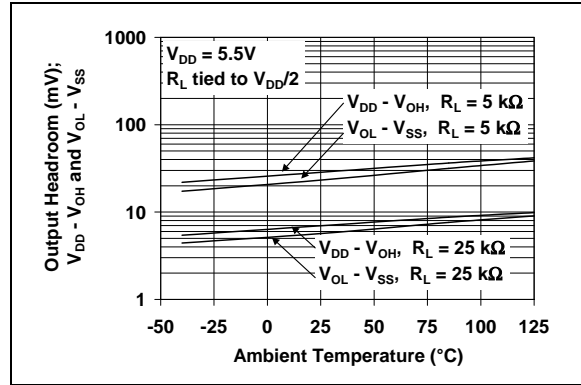
**FIGURE 2-19:** Gain Bandwidth Product, Phase Margin vs. Load Resistance.



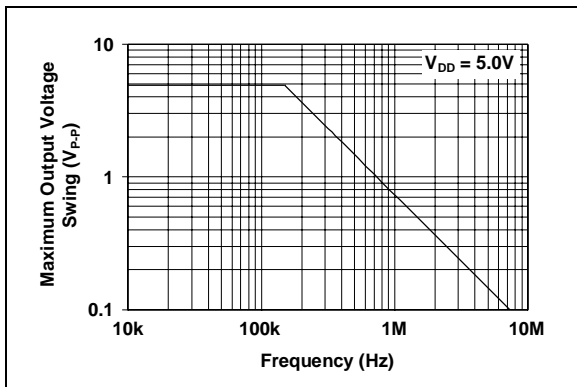
**FIGURE 2-22:** DC Open-Loop Gain vs. Temperature.



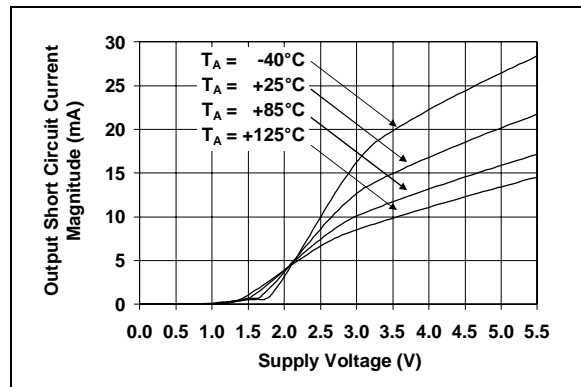
**FIGURE 2-20:** Output Voltage Headroom vs. Output Current.



**FIGURE 2-23:** Output Voltage Headroom vs. Temperature.



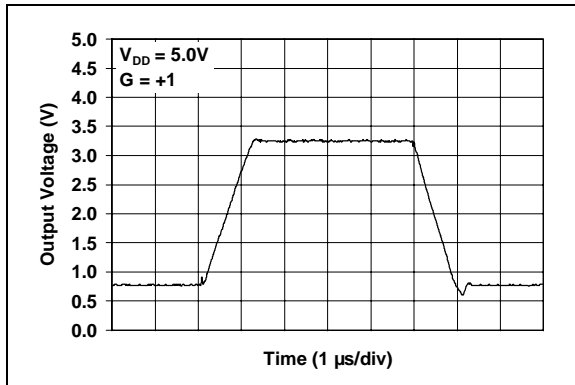
**FIGURE 2-21:** Maximum Output Voltage Swing vs. Frequency.



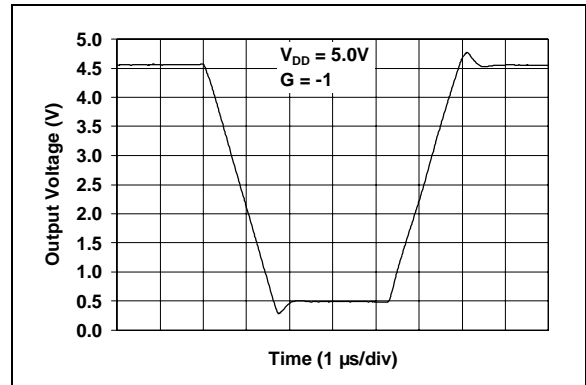
**FIGURE 2-24:** Output Short-Circuit Current vs. Supply Voltage.



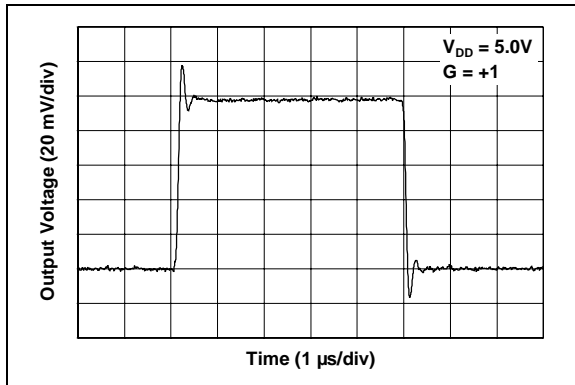
**Note:** Unless otherwise indicated,  $T_A = +25^\circ\text{C}$ ,  $V_{DD} = +2.7\text{V to } +5.5\text{V}$ ,  $V_{SS} = \text{GND}$ ,  $V_{CM} = V_{DD}/2$ ,  $R_L = 100\text{ k}\Omega$  to  $V_{DD}/2$ ,  $V_{OUT} \approx V_{DD}/2$ , and  $C_L = 50\text{ pF}$ .



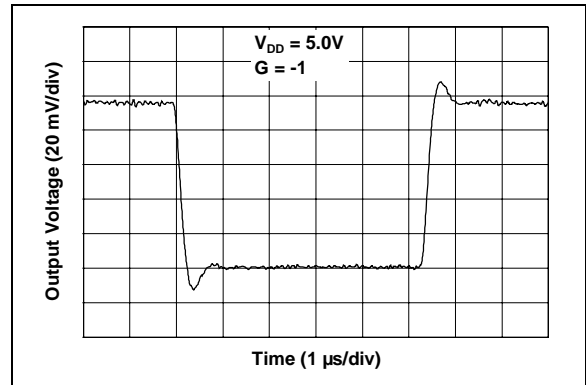
**FIGURE 2-25:** Large Signal Non-Inverting Pulse Response.



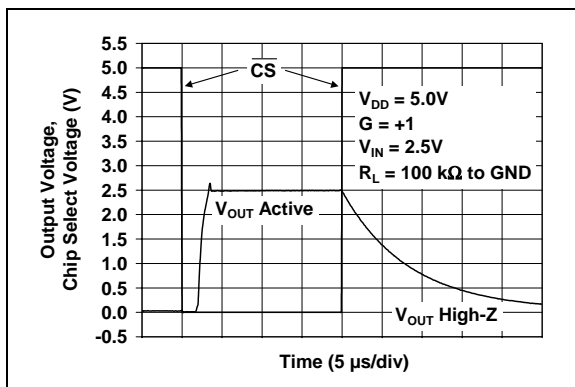
**FIGURE 2-28:** Large Signal Inverting Pulse Response.



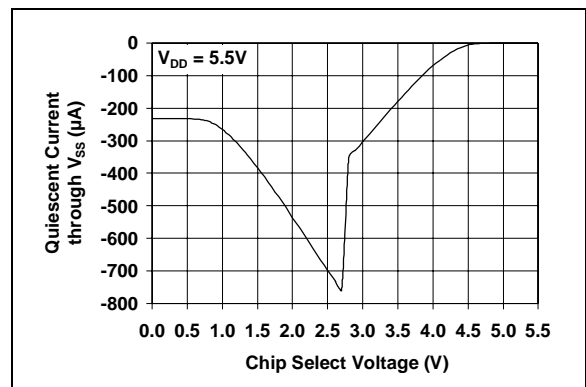
**FIGURE 2-26:** Small Signal Non-Inverting Pulse Response.



**FIGURE 2-29:** Small Signal Inverting Pulse Response.



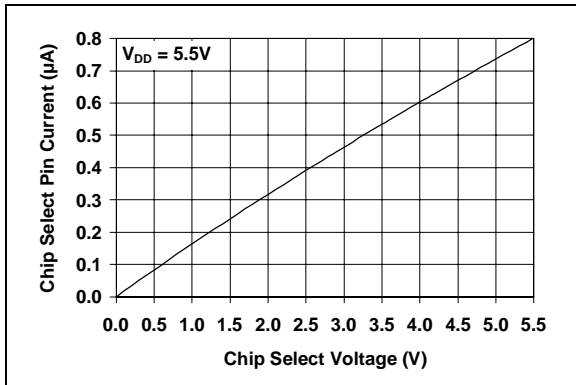
**FIGURE 2-27:** Chip Select Timing (MCP603).



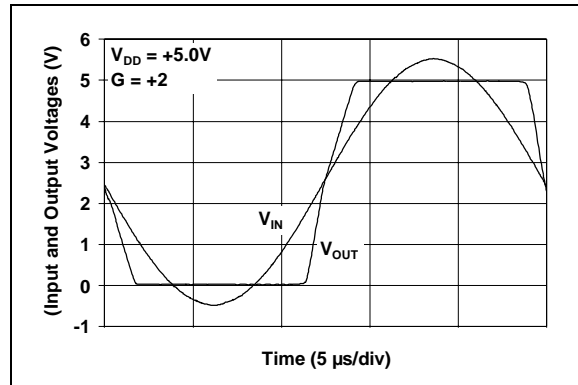
**FIGURE 2-30:** Quiescent Current Through  $V_{SS}$  vs. Chip Select Voltage (MCP603).

# MCP601/2/3/4

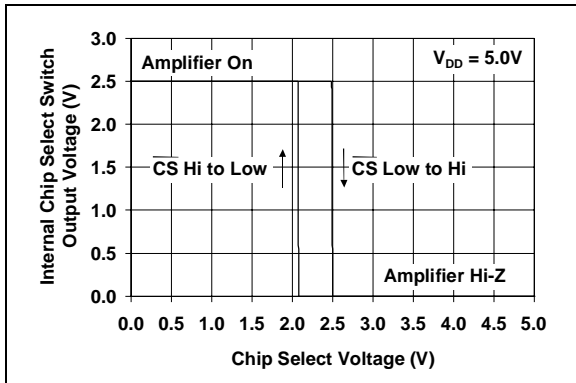
**Note:** Unless otherwise indicated,  $T_A = +25^\circ\text{C}$ ,  $V_{DD} = +2.7\text{V}$  to  $+5.5\text{V}$ ,  $V_{SS} = \text{GND}$ ,  $V_{CM} = V_{DD}/2$ ,  $R_L = 100\text{ k}\Omega$  to  $V_{DD}/2$ ,  $V_{OUT} \approx V_{DD}/2$ , and  $C_L = 50\text{ pF}$ .



**FIGURE 2-31:** Chip Select Pin Input Current vs. Chip Select Voltage.



**FIGURE 2-33:** The MCP601/2/3/4 family of op amps shows no phase reversal under input overdrive.



**FIGURE 2-32:** Hysteresis of Chip Select's Internal Switch.

## 3.0 APPLICATIONS INFORMATION

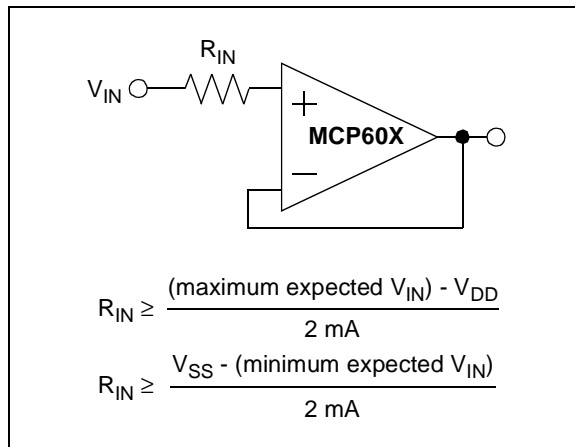
The MCP601/2/3/4 family of operational amplifiers are fabricated on Microchip's state-of-the-art CMOS process. They are unity-gain stable and suitable for a wide range of general purpose applications.

### 3.1 Input

The MCP601/2/3/4 amplifier family is designed to not exhibit phase reversal when the input pins exceed the supply rails. Figure 2-33 shows an input voltage that exceeds both supplies with no resulting phase inversion.

The Common Mode Input Voltage Range ( $V_{CMR}$ ) includes ground in single supply systems ( $V_{SS}$ ), but does not include  $V_{DD}$ . This means that the amplifier input behaves linearly as long as the Common Mode Input Voltage ( $V_{CM}$ ) is kept within the specified  $V_{CMR}$  limits ( $V_{SS}-0.3V$  to  $V_{DD}-1.2V$  at  $+25^{\circ}C$ ).

Input voltages that exceed the input voltage range ( $V_{SS}-0.3V$  to  $V_{DD}-1.2V$  at  $+25^{\circ}C$ ) can cause excessive current to flow into, or out of, the input pins. Current beyond  $\pm 2$  mA may cause reliability problems. Applications that exceed this rating must externally limit the input current with a resistor ( $R_{IN}$ ), as shown in Figure 3-1.



**FIGURE 3-1:**  $R_{IN}$  limits the current flow into an input pin.

### 3.2 Rail-to-Rail Output

There are two specifications that describe the output swing capability of the MCP601/2/3/4 family of operational amplifiers. The first specification, Maximum Output Voltage Swing, defines the absolute maximum swing that can be achieved under the specified load conditions. For instance, the output voltage swings to within 15 mV of the negative rail with a 25 k $\Omega$  load to  $V_{DD}/2$ . Figure 2-33 shows how the output voltage is limited when the input goes beyond the linear region of operation.

The second specification that describes the output swing capability of these amplifiers is the Linear Output Voltage Swing. This specification defines the maximum output swing that can be achieved while the amplifier is still operating in its linear region. To verify linear operation in this range, the large signal, DC Open-Loop Gain ( $A_{OL}$ ), is measured at points 100 mV inside the supply rails. The measurement must exceed the specified gains in the spec table.

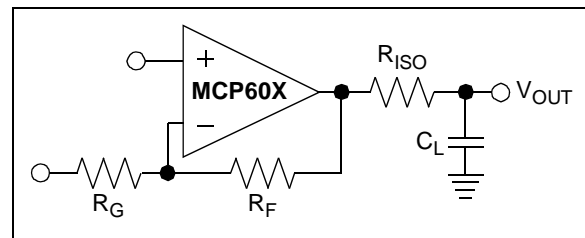
### 3.3 MCP603 Chip Select

The MCP603 is a single amplifier with Chip Select ( $\overline{CS}$ ). When  $\overline{CS}$  is pulled high, the supply current drops to -0.7  $\mu A$  (typ.), which is pulled through the  $\overline{CS}$  pin to  $V_{SS}$ . When this happens, the amplifier output is put into a high impedance state. Pulling  $\overline{CS}$  low enables the amplifier. If the  $\overline{CS}$  pin is left floating, the amplifier may not operate properly. Figure 1-1 is the Chip Select timing diagram and shows the output voltage, supply currents and  $\overline{CS}$  current in response to a  $\overline{CS}$  pulse. Figure 2-27 shows the measured output voltage response to a  $\overline{CS}$  pulse.

### 3.4 Capacitive Loads

Driving large capacitive loads can cause stability problems for voltage feedback op amps. As the load capacitance increases, the feedback loop's phase margin decreases and the closed-loop bandwidth is reduced. This produces gain peaking in the frequency response with overshoot and ringing in the step response.

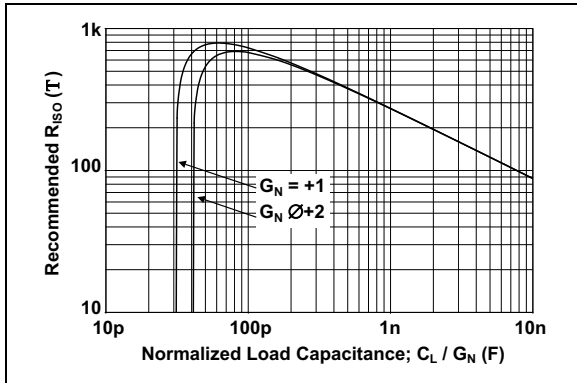
When driving large capacitive loads with these op amps (e.g., > 40 pF when  $G = +1$ ), a small series resistor at the output ( $R_{ISO}$  in Figure 3-2) improves the feedback loop's phase margin (stability) by making the output load resistive at higher frequencies. The bandwidth will be generally lower than the bandwidth with no capacitive load.



**FIGURE 3-2:** Output resistor  $R_{ISO}$  stabilizes large capacitive loads.

Figure 3-3 gives recommended  $R_{ISO}$  values for different capacitive loads and gains. The x-axis is the normalized load capacitance ( $C_L/G_N$ ) to make it easier to interpret the plot for arbitrary gains.  $G_N$  is the circuit's noise gain. For non-inverting gains,  $G_N$  and the gain are equal. For inverting gains,  $G_N$  is  $1+|\text{Gain}|$  (e.g., -1 V/V gives  $G_N = +2$  V/V).

# MCP601/2/3/4



**FIGURE 3-3:** Recommended  $R_{ISO}$  values for capacitive loads.

After selecting  $R_{ISO}$  for your circuit, double-check the resulting frequency response peaking and step response overshoot in your circuit. Evaluation on the bench and simulations with the MCP601/2/3/4 SPICE macro model are very helpful. Modify  $R_{ISO}$ 's value until the response is reasonable.

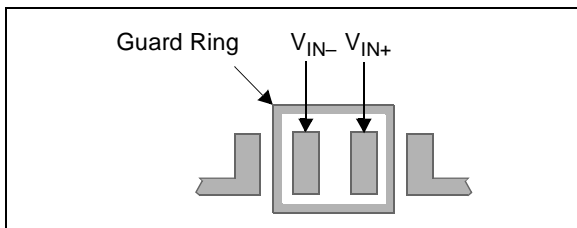
## 3.5 Supply Bypass

With this family of operational amplifiers, the power supply pin ( $V_{DD}$  for single supply) should have a local bypass capacitor (i.e., 0.01  $\mu\text{F}$  to 0.1  $\mu\text{F}$ ) within 2 mm for good high-frequency performance. It also needs a bulk capacitor (i.e., 1  $\mu\text{F}$  or larger) within 100 mm to provide large, slow currents. This bulk capacitor can be shared with other parts.

## 3.6 PCB Surface Leakage

In applications where low input bias current is critical, PCB (printed circuit board) surface leakage effects need to be considered. Surface leakage is caused by humidity, dust or other contamination on the board. Under low humidity conditions, a typical resistance between nearby traces is  $10^{12}\Omega$ . A 5V difference would cause 5 pA of current to flow. This is greater than the MCP601/2/3/4 family's bias current at +25°C (1 pA, typ.).

The easiest way to reduce surface leakage is to use a guard ring around sensitive pins (or traces). The guard ring is biased at the same voltage as the sensitive pin. An example of this type of layout is shown in Figure 3-4.



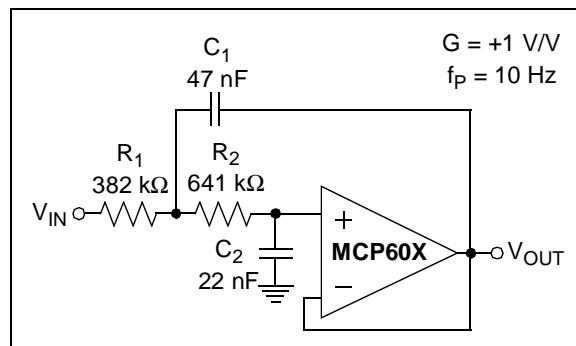
**FIGURE 3-4:** Example guard ring layout.

1. Connect the guard ring to the inverting input pin ( $V_{IN-}$ ) for non-inverting gain amplifiers, including unity-gain buffers. This biases the guard ring to the common mode input voltage.
2. Connect the guard ring to the non-inverting input pin ( $V_{IN+}$ ) for inverting gain amplifiers and transimpedance amplifiers (convert current to voltage, such as photo detectors). This biases the guard ring to the same reference voltage as the op amp (e.g.,  $V_{DD}/2$  or ground).

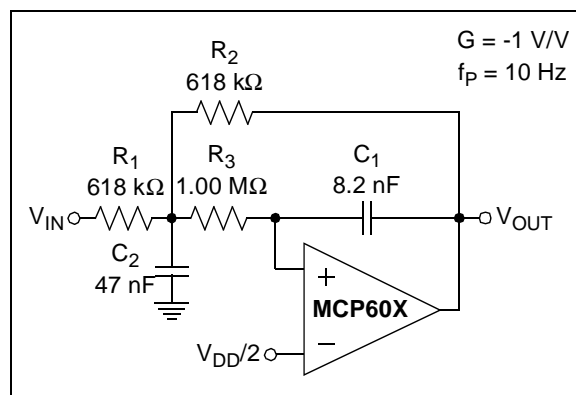
## 3.7 Typical Applications

### 3.7.1 ANALOG FILTERS

Figure 3-5 and Figure 3-6 show low-pass, second-order, Butterworth filters with a cutoff frequency of 10 Hz. The filter in Figure 3-5 has a non-inverting gain of +1 V/V, and the filter in Figure 3-6 has an inverting gain of -1 V/V.



**FIGURE 3-5:** 2<sup>nd</sup> order, low-pass Sallen-Key filter.



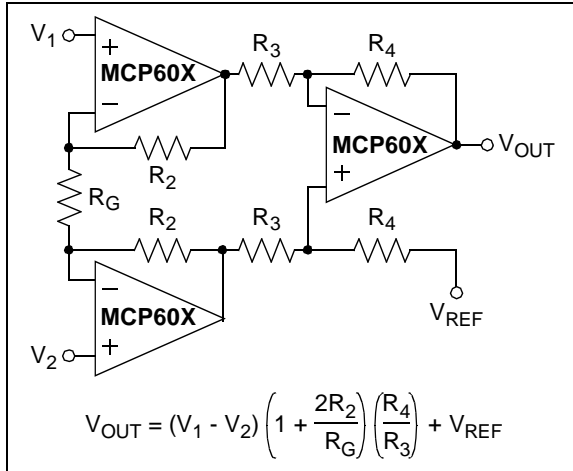
**FIGURE 3-6:** 2<sup>nd</sup> order, low-pass Multiple-Feedback filter.

The MCP601/2/3/4 family of operational amplifiers have low input bias current, which allows the designer to select larger resistor values and smaller capacitor values for these filters. This helps produce a compact PCB layout. These filters, and others, can be designed using Microchip's FilterLab<sup>®</sup> software.

## 3.7.2 INSTRUMENTATION AMPLIFIER CIRCUITS

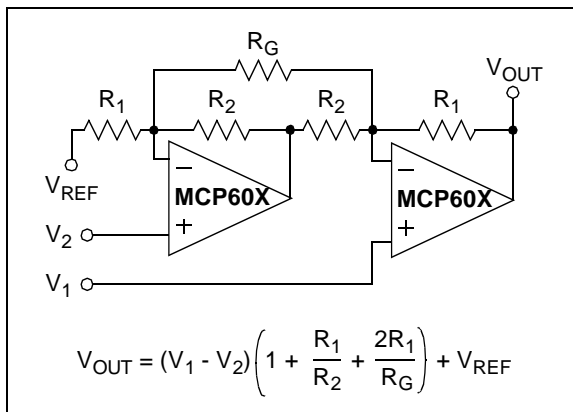
Instrumentation amplifiers have a differential input, which subtracts one input voltage from another and rejects common mode signals. These amplifiers also provide a single-ended output voltage.

The three op amp instrumentation amplifier is illustrated in Figure 3-7. One advantage of this approach is unity-gain operation. A disadvantage is that the common mode input range is reduced as  $R_2/R_G$  gets larger.



**FIGURE 3-7:** Three op amp instrumentation amplifier.

The two op amp instrumentation amplifier is shown in Figure 3-8. Its power consumption is lower than the three op amp version. Its main drawbacks are that the common mode range is reduced with higher gains and it must be configured in gains of two or higher.



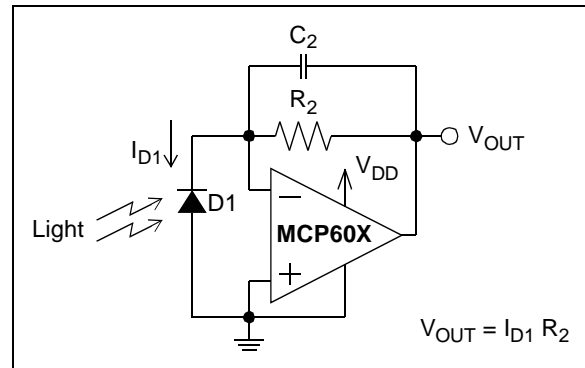
**FIGURE 3-8:** Two op amp instrumentation amplifier.

Both instrumentation amplifiers should use a bulk bypass capacitor of at least 1  $\mu$ F. The CMRR of these amplifiers will be set by the op amp CMRR and by resistor matching.

## 3.7.3 PHOTO DETECTION

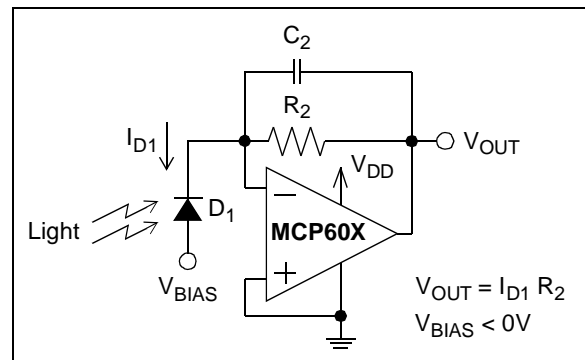
The MCP601/2/3/4 op amps can be used to easily convert the signal from a sensor that produces an output current (such as a photo diode) into a voltage (a transimpedance amplifier). This is implemented with a single resistor ( $R_2$ ) in the feedback loop of the amplifiers shown in Figure 3-9 and Figure 3-10. The optional capacitor ( $C_2$ ) sometimes provides stability for these circuits.

A photodiode configured in the photovoltaic mode has zero voltage potential placed across it (Figure 3-9). In this mode, the light sensitivity and linearity is maximized, making it best suited for precision applications. The key amplifier specifications for this application are: low input bias current, low noise, common mode input voltage range (including ground) and rail-to-rail output.



**FIGURE 3-9:** Photovoltaic mode detector.

In contrast, a photodiode that is configured in the photoconductive mode has a reverse bias voltage across the photo sensing element (Figure 3-10). This decreases the diode capacitance, which facilitates high-speed operation (e.g., high-speed digital communications). The design trade off is increased diode leakage current and linearity errors. The op amp needs to have a wide Gain Bandwidth Product.



**FIGURE 3-10:** Photoconductive Mode Detector.

# MCP601/2/3/4

---

## 4.0 DESIGN TOOLS

Microchip provides the basic design tools needed for the MCP601/2/3/4 family of op amps.

### 4.1 SPICE Macro Model

The latest SPICE macro model of the MCP601/2/3/4 operational amplifiers is available on our website (at [www.microchip.com](http://www.microchip.com)). This model is intended as an initial design tool that works well in the op amp's linear region of operation at room temperature. See the SPICE model file for information on its capabilities.

Bench testing is a very important part of any design and cannot be replaced with simulations. Also, simulation results using this macro model need to be validated by comparing them to the data sheet specs and plots.

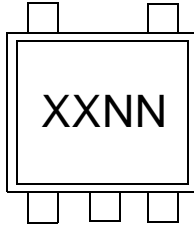
### 4.2 FilterLab<sup>®</sup> 2.0

FilterLab<sup>®</sup> 2.0 is an innovative software tool that simplifies analog active filter (using op amps) design. Available at no cost from our web site (at [www.microchip.com](http://www.microchip.com)), the FilterLab active filter software design tool provides full schematic diagrams of the filter circuit with component values. It also outputs the filter circuit in SPICE format, which can be used with the Macro Model to simulate actual filter performance.

## 5.0 PACKAGING INFORMATION

### 5.1 Package Marking Information

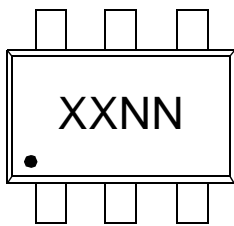
5-Lead SOT-23 (MCP601 and MCP601R Only)



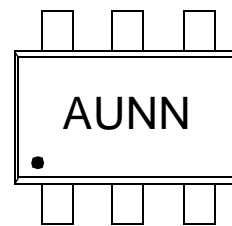
Example:



6-Lead SOT-23A (MCP603 Only)



Example:



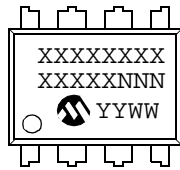
<b>Legend:</b>	XX...X	Customer specific information*
	YY	Year code (last 2 digits of calendar year)
	WW	Week code (week of January 1 is week '01')
	NNN	Alphanumeric traceability code
<b>Note:</b>	In the event the full Microchip part number cannot be marked on one line, it will be carried over to the next line thus limiting the number of available characters for customer specific information.	

\* Standard OTP marking consists of Microchip part number, year code, week code, and traceability code.

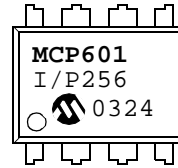
# MCP601/2/3/4

## Package Marking Information

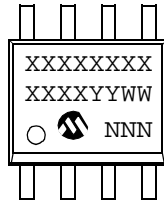
8-Lead PDIP (300 mil)



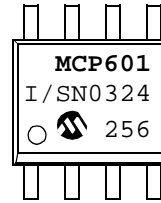
Example:



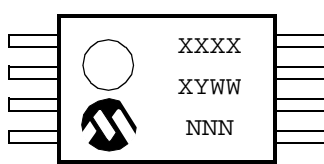
8-Lead SOIC (150 mil)



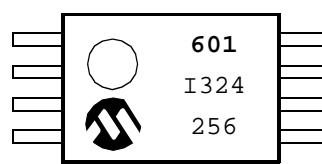
Example:



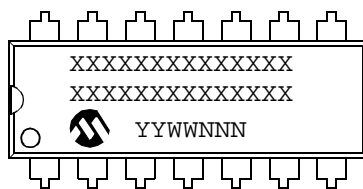
8-Lead TSSOP



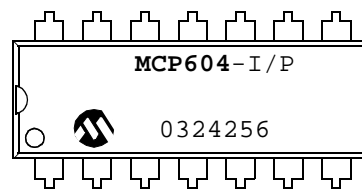
Example:



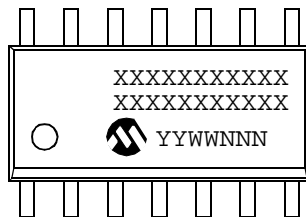
14-Lead PDIP (300 mil) (MCP604 Only)



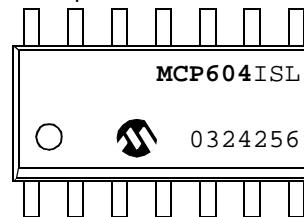
Example:



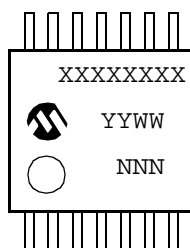
14-Lead SOIC (150 mil) (MCP604 Only)



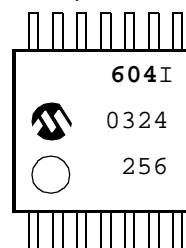
Example:



14-Lead TSSOP (4.4mm) (MCP604 Only)

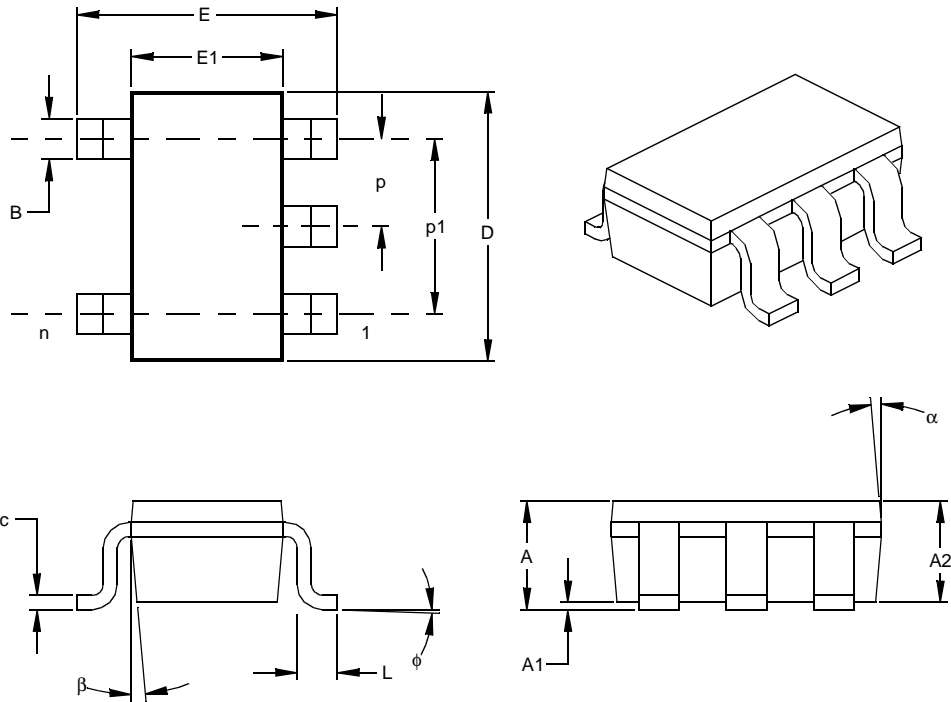


Example:





## 5-Lead Plastic Small Outline Transistor (OT) (SOT-23)



Units		INCHES*			MILLIMETERS		
Dimension Limits		MIN	NOM	MAX	MIN	NOM	MAX
Number of Pins	n		5			5	
Pitch	p		.038			0.95	
Outside lead pitch (basic)	p1		.075			1.90	
Overall Height	A	.035	.046	.057	0.90	1.18	1.45
Molded Package Thickness	A2	.035	.043	.051	0.90	1.10	1.30
Standoff §	A1	.000	.003	.006	0.00	0.08	0.15
Overall Width	E	.102	.110	.118	2.60	2.80	3.00
Molded Package Width	E1	.059	.064	.069	1.50	1.63	1.75
Overall Length	D	.110	.116	.122	2.80	2.95	3.10
Foot Length	L	.014	.018	.022	0.35	0.45	0.55
Foot Angle	φ	0	5	10	0	5	10
Lead Thickness	c	.004	.006	.008	0.09	0.15	0.20
Lead Width	B	.014	.017	.020	0.35	0.43	0.50
Mold Draft Angle Top	α	0	5	10	0	5	10
Mold Draft Angle Bottom	β	0	5	10	0	5	10

\* Controlling Parameter  
 § Significant Characteristic

Notes:

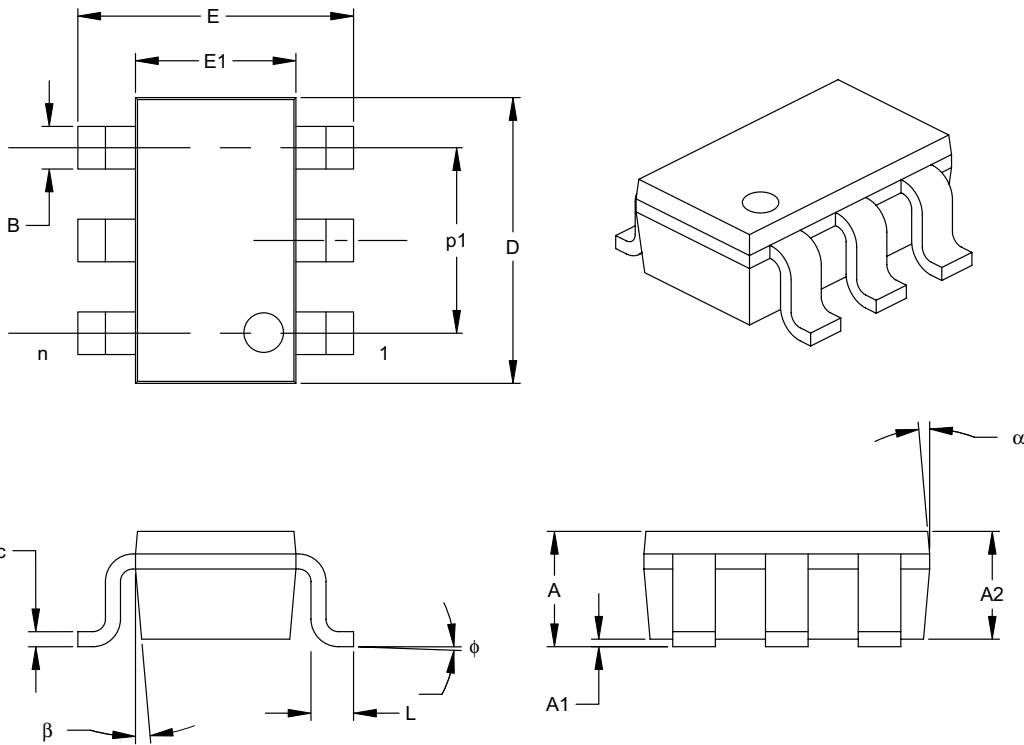
Dimensions D and E1 do not include mold flash or protrusions. Mold flash or protrusions shall not exceed .010" (0.254mm) per side.

JEDEC Equivalent: MO-178

Drawing No. C04-091

# MCP601/2/3/4

## 6-Lead Plastic Small Outline Transistor (CH) (SOT-23)



Dimension Limits	Units	INCHES*			MILLIMETERS		
		MIN	NOM	MAX	MIN	NOM	MAX
Number of Pins	n		6			6	
Pitch	p		.038			0.95	
Outside lead pitch (basic)	p1		.075			1.90	
Overall Height	A	.035	.046	.057	0.90	1.18	1.45
Molded Package Thickness	A2	.035	.043	.051	0.90	1.10	1.30
Standoff	A1	.000	.003	.006	0.00	0.08	0.15
Overall Width	E	.102	.110	.118	2.60	2.80	3.00
Molded Package Width	E1	.059	.064	.069	1.50	1.63	1.75
Overall Length	D	.110	.116	.122	2.80	2.95	3.10
Foot Length	L	.014	.018	.022	0.35	0.45	0.55
Foot Angle	φ	0	5	10	0	5	10
Lead Thickness	c	.004	.006	.008	0.09	0.15	0.20
Lead Width	B	.014	.017	.020	0.35	0.43	0.50
Mold Draft Angle Top	α	0	5	10	0	5	10
Mold Draft Angle Bottom	β	0	5	10	0	5	10

\*Controlling Parameter

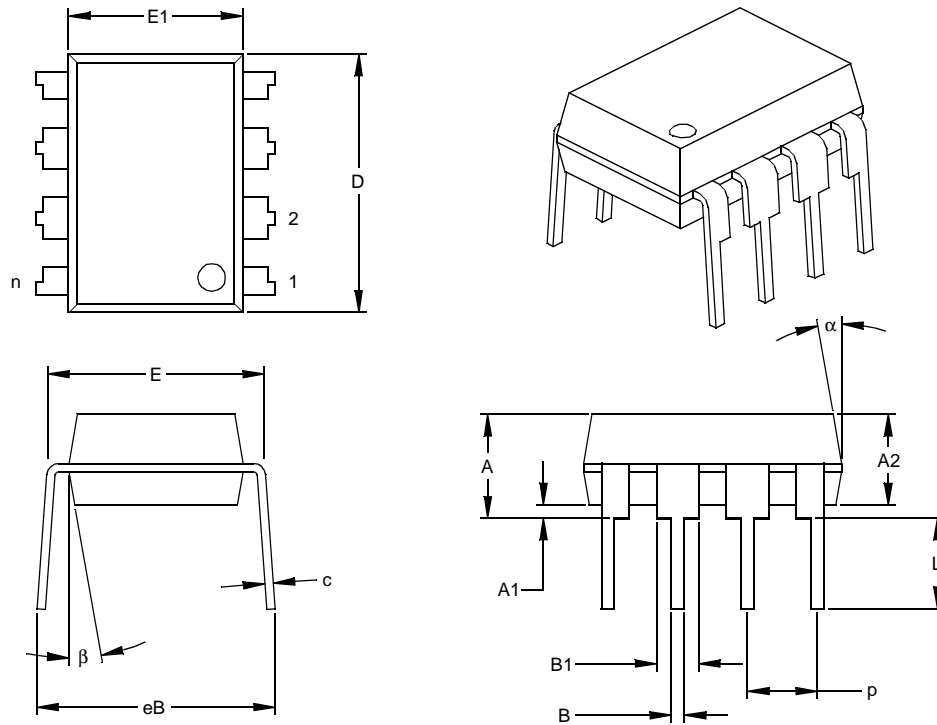
Notes:

Dimensions D and E1 do not include mold flash or protrusions. Mold flash or protrusions shall not exceed .005" (0.127mm) per side.

JEITA (formerly EIAJ) equivalent: SC-74A

Drawing No. C04-120

## 8-Lead Plastic Dual In-line (P) – 300 mil (PDIP)



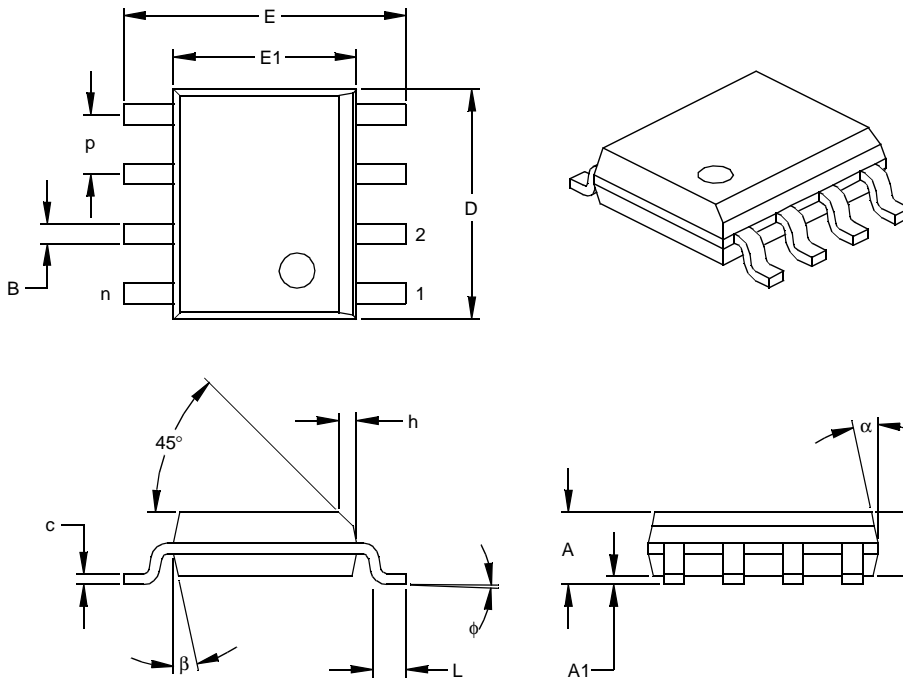
Units		INCHES*			MILLIMETERS		
Dimension Limits		MIN	NOM	MAX	MIN	NOM	MAX
Number of Pins	n		8			8	
Pitch	p		.100			2.54	
Top to Seating Plane	A	.140	.155	.170	3.56	3.94	4.32
Molded Package Thickness	A2	.115	.130	.145	2.92	3.30	3.68
Base to Seating Plane	A1	.015			0.38		
Shoulder to Shoulder Width	E	.300	.313	.325	7.62	7.94	8.26
Molded Package Width	E1	.240	.250	.260	6.10	6.35	6.60
Overall Length	D	.360	.373	.385	9.14	9.46	9.78
Tip to Seating Plane	L	.125	.130	.135	3.18	3.30	3.43
Lead Thickness	c	.008	.012	.015	0.20	0.29	0.38
Upper Lead Width	B1	.045	.058	.070	1.14	1.46	1.78
Lower Lead Width	B	.014	.018	.022	0.36	0.46	0.56
Overall Row Spacing	§ eB	.310	.370	.430	7.87	9.40	10.92
Mold Draft Angle Top	α	5	10	15	5	10	15
Mold Draft Angle Bottom	β	5	10	15	5	10	15

\* Controlling Parameter  
 § Significant Characteristic

Notes:  
 Dimensions D and E1 do not include mold flash or protrusions. Mold flash or protrusions shall not exceed .010" (0.254mm) per side.  
 JEDEC Equivalent: MS-001  
 Drawing No. C04-018

# MCP601/2/3/4

## 8-Lead Plastic Small Outline (SN) – Narrow, 150 mil (SOIC)

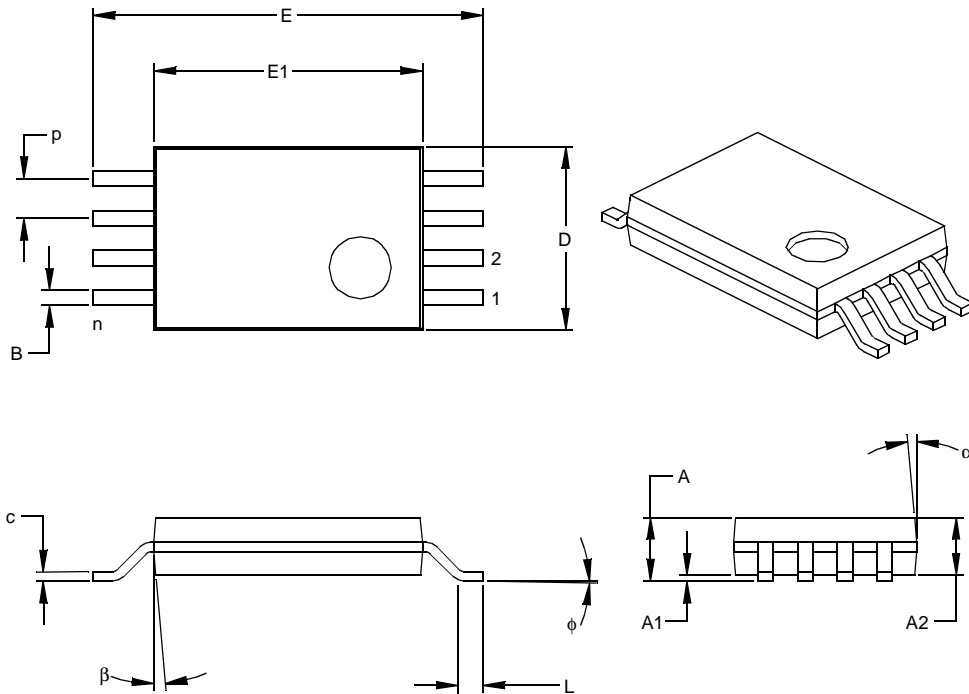


Dimension Limits	Units	INCHES*			MILLIMETERS		
		MIN	NOM	MAX	MIN	NOM	MAX
Number of Pins	n		8			8	
Pitch	p		.050			1.27	
Overall Height	A	.053	.061	.069	1.35	1.55	1.75
Molded Package Thickness	A2	.052	.056	.061	1.32	1.42	1.55
Standoff §	A1	.004	.007	.010	0.10	0.18	0.25
Overall Width	E	.228	.237	.244	5.79	6.02	6.20
Molded Package Width	E1	.146	.154	.157	3.71	3.91	3.99
Overall Length	D	.189	.193	.197	4.80	4.90	5.00
Chamfer Distance	h	.010	.015	.020	0.25	0.38	0.51
Foot Length	L	.019	.025	.030	0.48	0.62	0.76
Foot Angle	φ	0	4	8	0	4	8
Lead Thickness	c	.008	.009	.010	0.20	0.23	0.25
Lead Width	B	.013	.017	.020	0.33	0.42	0.51
Mold Draft Angle Top	α	0	12	15	0	12	15
Mold Draft Angle Bottom	β	0	12	15	0	12	15

\* Controlling Parameter  
 § Significant Characteristic

Notes:  
 Dimensions D and E1 do not include mold flash or protrusions. Mold flash or protrusions shall not exceed .010" (0.254mm) per side.  
 JEDEC Equivalent: MS-012  
 Drawing No. C04-057

## 8-Lead Plastic Thin Shrink Small Outline (ST) – 4.4 mm (TSSOP)



Units		INCHES			MILLIMETERS*		
Dimension	Limits	MIN	NOM	MAX	MIN	NOM	MAX
Number of Pins	n		8			8	
Pitch	p		.026			0.65	
Overall Height	A			.043			1.10
Molded Package Thickness	A2	.033	.035	.037	0.85	0.90	0.95
Standoff §	A1	.002	.004	.006	0.05	0.10	0.15
Overall Width	E	.246	.251	.256	6.25	6.38	6.50
Molded Package Width	E1	.169	.173	.177	4.30	4.40	4.50
Molded Package Length	D	.114	.118	.122	2.90	3.00	3.10
Foot Length	L	.020	.024	.028	0.50	0.60	0.70
Foot Angle	φ	0	4	8	0	4	8
Lead Thickness	c	.004	.006	.008	0.09	0.15	0.20
Lead Width	B	.007	.010	.012	0.19	0.25	0.30
Mold Draft Angle Top	α	0	5	10	0	5	10
Mold Draft Angle Bottom	β	0	5	10	0	5	10

\* Controlling Parameter

§ Significant Characteristic

**Notes:**

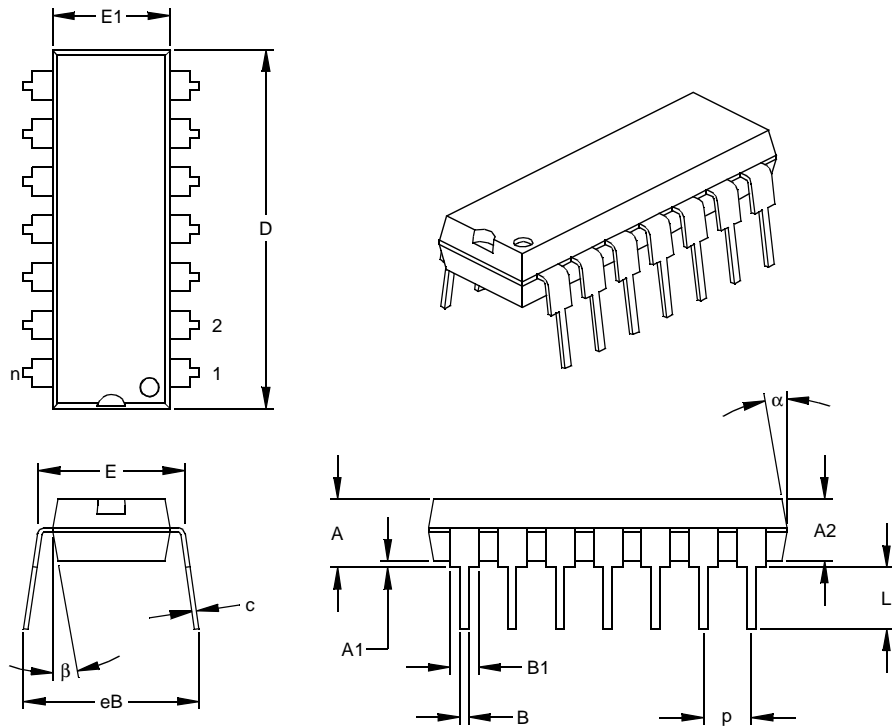
Dimensions D and E1 do not include mold flash or protrusions. Mold flash or protrusions shall not exceed .005" (0.127mm) per side.

JEDEC Equivalent: MO-153

Drawing No. C04-086

# MCP601/2/3/4

## 14-Lead Plastic Dual In-line (P) – 300 mil (PDIP)



Dimension Limits	Units	INCHES*			MILLIMETERS		
		MIN	NOM	MAX	MIN	NOM	MAX
Number of Pins	n		14			14	
Pitch	p		.100			2.54	
Top to Seating Plane	A	.140	.155	.170	3.56	3.94	4.32
Molded Package Thickness	A2	.115	.130	.145	2.92	3.30	3.68
Base to Seating Plane	A1	.015			0.38		
Shoulder to Shoulder Width	E	.300	.313	.325	7.62	7.94	8.26
Molded Package Width	E1	.240	.250	.260	6.10	6.35	6.60
Overall Length	D	.740	.750	.760	18.80	19.05	19.30
Tip to Seating Plane	L	.125	.130	.135	3.18	3.30	3.43
Lead Thickness	c	.008	.012	.015	0.20	0.29	0.38
Upper Lead Width	B1	.045	.058	.070	1.14	1.46	1.78
Lower Lead Width	B	.014	.018	.022	0.36	0.46	0.56
Overall Row Spacing	§ eB	.310	.370	.430	7.87	9.40	10.92
Mold Draft Angle Top	α	5	10	15	5	10	15
Mold Draft Angle Bottom	β	5	10	15	5	10	15

\* Controlling Parameter

§ Significant Characteristic

Notes:

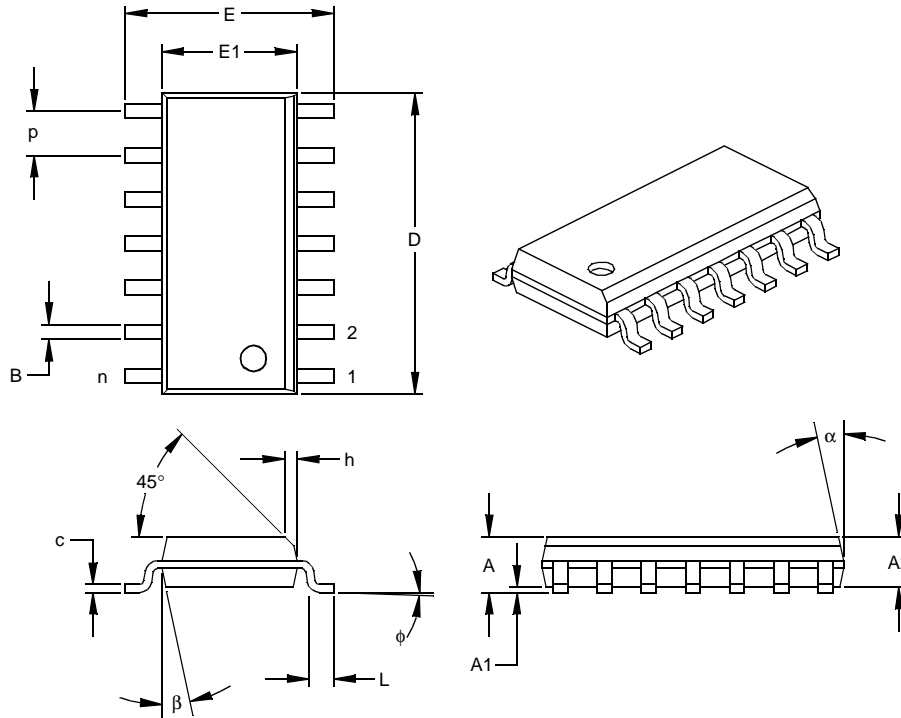
Dimensions D and E1 do not include mold flash or protrusions. Mold flash or protrusions shall not exceed

.010" (0.254mm) per side.

JEDEC Equivalent: MS-001

Drawing No. C04-005

## 14-Lead Plastic Small Outline (SL) – Narrow, 150 mil (SOIC)



Units		INCHES*			MILLIMETERS		
Dimension Limits		MIN	NOM	MAX	MIN	NOM	MAX
Number of Pins	n		14			14	
Pitch	p		.050			1.27	
Overall Height	A	.053	.061	.069	1.35	1.55	1.75
Molded Package Thickness	A2	.052	.056	.061	1.32	1.42	1.55
Standoff §	A1	.004	.007	.010	0.10	0.18	0.25
Overall Width	E	.228	.236	.244	5.79	5.99	6.20
Molded Package Width	E1	.150	.154	.157	3.81	3.90	3.99
Overall Length	D	.337	.342	.347	8.56	8.69	8.81
Chamfer Distance	h	.010	.015	.020	0.25	0.38	0.51
Foot Length	L	.016	.033	.050	0.41	0.84	1.27
Foot Angle	φ	0	4	8	0	4	8
Lead Thickness	c	.008	.009	.010	0.20	0.23	0.25
Lead Width	B	.014	.017	.020	0.36	0.42	0.51
Mold Draft Angle Top	α	0	12	15	0	12	15
Mold Draft Angle Bottom	β	0	12	15	0	12	15

\* Controlling Parameter  
 § Significant Characteristic

Notes:

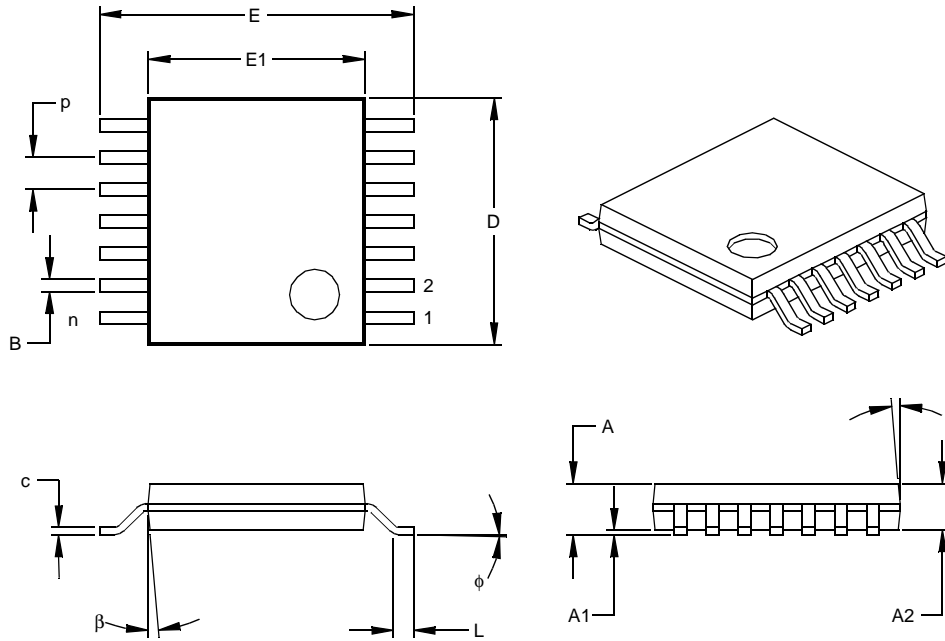
Dimensions D and E1 do not include mold flash or protrusions. Mold flash or protrusions shall not exceed .010" (0.254mm) per side.

JEDEC Equivalent: MS-012

Drawing No. C04-065

# MCP601/2/3/4

## 14-Lead Plastic Thin Shrink Small Outline (ST) – 4.4 mm (TSSOP)



Units		INCHES			MILLIMETERS*		
Dimension Limits		MIN	NOM	MAX	MIN	NOM	MAX
Number of Pins	n		14			14	
Pitch	p		.026			0.65	
Overall Height	A			.043			1.10
Molded Package Thickness	A2	.033	.035	.037	0.85	0.90	0.95
Standoff §	A1	.002	.004	.006	0.05	0.10	0.15
Overall Width	E	.246	.251	.256	6.25	6.38	6.50
Molded Package Width	E1	.169	.173	.177	4.30	4.40	4.50
Molded Package Length	D	.193	.197	.201	4.90	5.00	5.10
Foot Length	L	.020	.024	.028	0.50	0.60	0.70
Foot Angle	φ	0	4	8	0	4	8
Lead Thickness	c	.004	.006	.008	0.09	0.15	0.20
Lead Width	B	.007	.010	.012	0.19	0.25	0.30
Mold Draft Angle Top	α	0	5	10	0	5	10
Mold Draft Angle Bottom	β	0	5	10	0	5	10

\* Controlling Parameter  
 § Significant Characteristic

### Notes:

Dimensions D and E1 do not include mold flash or protrusions. Mold flash or protrusions shall not exceed .005" (0.127mm) per side.

JEDEC Equivalent: MO-153

Drawing No. C04-087



## PRODUCT IDENTIFICATION SYSTEM

To order or obtain information, e.g., on pricing or delivery, refer to the factory or the listed sales office.

PART NO.	X	/XX	
Device	Temperature Range	Package	
Device	MCP601	Single Op Amp	
	MCP601T	Single Op Amp (Tape and Reel for SOT23, SOIC and TSSOP)	
	MCP601RT	Single Op Amp (Tape and Reel for SOT23-5)	
	MCP602	Dual Op Amp	
	MCP602T	Dual Op Amp (Tape and Reel for SOIC and TSSOP)	
	MCP603	Single Op Amp with Chip Select	
	MCP603T	Single Op Amp with Chip Select (Tape and Reel for SOT23, SOIC and TSSOP)	
	MCP604	Quad Op Amp	
	MCP604T	Quad Op Amp (Tape and Reel for SOIC and TSSOP)	
Temperature Range	I	= -40°C to +85°C	
	E	= -40°C to +125°C	
Package	OT	= Plastic SOT23, 5-lead ( <b>MCP601 only</b> )	
	CH	= Plastic SOT23, 6-lead ( <b>MCP603 only</b> )	
	P	= Plastic DIP (300 mil Body), 8, 14-lead	
	SN	= Plastic SOIC (150 mil Body), 8-lead	
	SL	= Plastic SOIC (150 mil Body), 14-lead	
	ST	= Plastic TSSOP (4.4mm Body), 8, 14-lead	
<b>Examples:</b>			
a)	MCP601-I/P:	Single Op Amp, Industrial Temp., 8LD PDIP package.	
b)	MCP601-E/SN:	Single Op Amp, Extended Temp., 8LD SOIC package.	
c)	MCP601T-I/OT:	Tape and Reel, Industrial Temp., Single Op Amp, 5-LD SOT23 package.	
d)	MCP601T-E/ST:	Tape and Reel, Extended Temp., Single Op Amp, 8LD TSSOP package	
e)	MCP601RT-E/OT:	Tape and Reel, Extended Temp., Single Op Amp, Rotated, 5-LD SOT23 package.	
a)	MCP602-I/SN:	Dual Op Amp, Industrial Temp., 8LD SOIC package.	
b)	MCP602-E/P:	Dual Op Amp, Extended Temp., 8LD PDIP package.	
c)	MCP602T-E/ST:	Tape and Reel, Extended Temp., Dual Op Amp, 8LD TSSOP package.	
a)	MCP603-I/SN:	Industrial Temp., Single Op Amp with Chip Select, 8LD SOIC package.	
b)	MCP603-E/P:	Extended Temp., Single Op Amp with Chip Select, 8LD PDIP package.	
c)	MCP603T-E/ST:	Tape and Reel, Extended Temp., Single Op Amp with Chip Select, 8LD TSSOP package.	
d)	MCP603T-I/SN:	Tape and Reel, Industrial Temp., Single Op Amp with Chip Select, 8LD SOIC package.	
a)	MCP604-I/P:	Industrial Temp., Quad Op Amp, 14LD PDIP package.	
b)	MCP604-E/SL:	Extended Temp., Quad Op Amp, 14LD SOIC package.	
c)	MCP604T-I/ST:	Tape and Reel, Industrial Temp., Quad Op Amp, 14LD TSSOP package.	

## Sales and Support

### Data Sheets

Products supported by a preliminary Data Sheet may have an errata sheet describing minor operational differences and recommended workarounds. To determine if an errata sheet exists for a particular device, please contact one of the following:

1. Your local Microchip sales office
2. The Microchip Corporate Literature Center U.S. FAX: (480) 792-7277
3. The Microchip Worldwide Site ([www.microchip.com](http://www.microchip.com))

Please specify which device, revision of silicon and Data Sheet (include Literature #) you are using.

### Customer Notification System

Register on our web site ([www.microchip.com/cn](http://www.microchip.com/cn)) to receive the most current information on our products.

# MCP601/2/3/4

---

NOTES:

---

---

**Note the following details of the code protection feature on Microchip devices:**

- Microchip products meet the specification contained in their particular Microchip Data Sheet.
- Microchip believes that its family of products is one of the most secure families of its kind on the market today, when used in the intended manner and under normal conditions.
- There are dishonest and possibly illegal methods used to breach the code protection feature. All of these methods, to our knowledge, require using the Microchip products in a manner outside the operating specifications contained in Microchip's Data Sheets. Most likely, the person doing so is engaged in theft of intellectual property.
- Microchip is willing to work with the customer who is concerned about the integrity of their code.
- Neither Microchip nor any other semiconductor manufacturer can guarantee the security of their code. Code protection does not mean that we are guaranteeing the product as "unbreakable."

Code protection is constantly evolving. We at Microchip are committed to continuously improving the code protection features of our products. Attempts to break microchip's code protection feature may be a violation of the Digital Millennium Copyright Act. If such acts allow unauthorized access to your software or other copyrighted work, you may have a right to sue for relief under that Act.

---

Information contained in this publication regarding device applications and the like is intended through suggestion only and may be superseded by updates. It is your responsibility to ensure that your application meets with your specifications. No representation or warranty is given and no liability is assumed by Microchip Technology Incorporated with respect to the accuracy or use of such information, or infringement of patents or other intellectual property rights arising from such use or otherwise. Use of Microchip's products as critical components in life support systems is not authorized except with express written approval by Microchip. No licenses are conveyed, implicitly or otherwise, under any intellectual property rights.

**Trademarks**

The Microchip name and logo, the Microchip logo, Accuron, dsPIC, KEELoQ, MPLAB, PIC, PICmicro, PICSTART, PRO MATE and PowerSmart are registered trademarks of Microchip Technology Incorporated in the U.S.A. and other countries.


AmpLab, FilterLab, microID, MXDEV, MXLAB, PICMASTER, SEEVAL and The Embedded Control Solutions Company are registered trademarks of Microchip Technology Incorporated in the U.S.A.

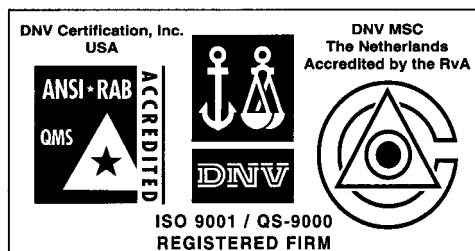
Application Maestro, dsPICDEM, dsPICDEM.net, ECAN, ECONOMONITOR, FanSense, FlexROM, fuzzyLAB, In-Circuit Serial Programming, ICSP, ICEPIC, microPort, Migratable Memory, MPASM, MPLIB, MPLINK, MPSIM, PICKit, PICDEM, PICDEM.net, PowerCal, PowerInfo, PowerMate, PowerTool, rfLAB, rfPIC, Select Mode, SmartSensor, SmartShunt, SmartTel and Total Endurance are trademarks of Microchip Technology Incorporated in the U.S.A. and other countries.

Serialized Quick Turn Programming (SQTP) is a service mark of Microchip Technology Incorporated in the U.S.A.

All other trademarks mentioned herein are property of their respective companies.

© 2003, Microchip Technology Incorporated, Printed in the U.S.A., All Rights Reserved.

 Printed on recycled paper.



*Microchip received QS-9000 quality system certification for its worldwide headquarters, design and wafer fabrication facilities in Chandler and Tempe, Arizona in July 1999 and Mountain View, California in March 2002. The Company's quality system processes and procedures are QS-9000 compliant for its PICmicro® 8-bit MCUs, KEELoQ® code hopping devices, Serial EEPROMs, microperipherals, non-volatile memory and analog products. In addition, Microchip's quality system for the design and manufacture of development systems is ISO 9001 certified.*



## WORLDWIDE SALES AND SERVICE

### AMERICAS

#### Corporate Office

2355 West Chandler Blvd.  
Chandler, AZ 85224-6199  
Tel: 480-792-7200  
Fax: 480-792-7277  
Technical Support: 480-792-7627  
Web Address: <http://www.microchip.com>

#### Atlanta

3780 Mansell Road, Suite 130  
Alpharetta, GA 30022  
Tel: 770-640-0034  
Fax: 770-640-0307

#### Boston

2 Lan Drive, Suite 120  
Westford, MA 01886  
Tel: 978-692-3848  
Fax: 978-692-3821

#### Chicago

333 Pierce Road, Suite 180  
Itasca, IL 60143  
Tel: 630-285-0071  
Fax: 630-285-0075

#### Dallas

4570 Westgrove Drive, Suite 160  
Addison, TX 75001  
Tel: 972-818-7423  
Fax: 972-818-2924

#### Detroit

Tri-Atria Office Building  
32255 Northwestern Highway, Suite 190  
Farmington Hills, MI 48334  
Tel: 248-538-2250  
Fax: 248-538-2260

#### Kokomo

2767 S. Albright Road  
Kokomo, IN 46902  
Tel: 765-864-8360  
Fax: 765-864-8387

#### Los Angeles

18201 Von Karman, Suite 1090  
Irvine, CA 92612  
Tel: 949-263-1888  
Fax: 949-263-1338

#### Phoenix

2355 West Chandler Blvd.  
Chandler, AZ 85224-6199  
Tel: 480-792-7966  
Fax: 480-792-4338

#### San Jose

2107 North First Street, Suite 590  
San Jose, CA 95131  
Tel: 408-436-7950  
Fax: 408-436-7955

#### Toronto

6285 Northam Drive, Suite 108  
Mississauga, Ontario L4V 1X5, Canada  
Tel: 905-673-0699  
Fax: 905-673-6509

### ASIA/PACIFIC

#### Australia

Suite 22, 41 Rawson Street  
Epping 2121, NSW  
Australia  
Tel: 61-2-9868-6733  
Fax: 61-2-9868-6755

#### China - Beijing

Unit 915  
Bei Hai Wan Tai Bldg.  
No. 6 Chaoyangmen Beidajie  
Beijing, 100027, No. China  
Tel: 86-10-85282100  
Fax: 86-10-85282104

#### China - Chengdu

Rm. 2401-2402, 24th Floor,  
Ming Xing Financial Tower  
No. 88 TIDU Street  
Chengdu 610016, China  
Tel: 86-28-86766200  
Fax: 86-28-86766599

#### China - Fuzhou

Unit 28F, World Trade Plaza  
No. 71 Wusi Road  
Fuzhou 350001, China  
Tel: 86-591-7503506  
Fax: 86-591-7503521

#### China - Hong Kong SAR

Unit 901-6, Tower 2, Metroplaza  
223 Hing Fong Road  
Kwai Fong, N.T., Hong Kong  
Tel: 852-2401-1200  
Fax: 852-2401-3431

#### China - Shanghai

Room 701, Bldg. B  
Far East International Plaza  
No. 317 Xian Xia Road  
Shanghai, 200051  
Tel: 86-21-6275-5700  
Fax: 86-21-6275-5060

#### China - Shenzhen

Rm. 1812, 18/F, Building A, United Plaza  
No. 5022 Binhe Road, Futian District  
Shenzhen 518033, China  
Tel: 86-755-82901380  
Fax: 86-755-8295-1393

#### China - Shunde

Room 401, Hongjian Building  
No. 2 Fengxiangnan Road, Ronggui Town  
Shunde City, Guangdong 528303, China  
Tel: 86-765-8395507 Fax: 86-765-8395571

#### China - Qingdao

Rm. B505A, Fullhope Plaza,  
No. 12 Hong Kong Central Rd.  
Qingdao 266071, China  
Tel: 86-532-5027355 Fax: 86-532-5027205

#### India

Divyasree Chambers  
1 Floor, Wing A (A3/A4)  
No. 11, O'Shaughnessy Road  
Bangalore, 560 025, India  
Tel: 91-80-2290061 Fax: 91-80-2290062

#### Japan

Benex S-1 6F  
3-18-20, Shinyokohama  
Kohoku-Ku, Yokohama-shi  
Kanagawa, 222-0033, Japan  
Tel: 81-45-471-6166 Fax: 81-45-471-6122

#### Korea

168-1, Youngbo Bldg. 3 Floor  
Samsung-Dong, Kangnam-Ku  
Seoul, Korea 135-882  
Tel: 82-2-554-7200 Fax: 82-2-558-5932 or  
82-2-558-5934

#### Singapore

200 Middle Road  
#07-02 Prime Centre  
Singapore, 188980  
Tel: 65-6334-8870 Fax: 65-6334-8850

#### Taiwan

Kaohsiung Branch  
30F - 1 No. 8  
Min Chuan 2nd Road  
Kaohsiung 806, Taiwan  
Tel: 886-7-536-4818  
Fax: 886-7-536-4803

#### Taiwan

Taiwan Branch  
11F-3, No. 207  
Tung Hua North Road  
Taipei, 105, Taiwan  
Tel: 886-2-2717-7175 Fax: 886-2-2545-0139

### EUROPE

#### Austria

Durisolstrasse 2  
A-4600 Wels  
Austria  
Tel: 43-7242-2244-399  
Fax: 43-7242-2244-393

#### Denmark

Regus Business Centre  
Lautrup hoj 1-3  
Ballerup DK-2750 Denmark  
Tel: 45-4420-9895 Fax: 45-4420-9910

#### France

Parc d'Activite du Moulin de Massy  
43 Rue du Saule Trapu  
Batiment A - ler Etage  
91300 Massy, France  
Tel: 33-1-69-53-63-20  
Fax: 33-1-69-30-90-79

#### Germany

Steinheilstrasse 10  
D-85737 Ismaning, Germany  
Tel: 49-89-627-144-0  
Fax: 49-89-627-144-44

#### Italy

Via Quasimodo, 12  
20025 Legnano (MI)  
Milan, Italy  
Tel: 39-0331-742611  
Fax: 39-0331-466781

#### Netherlands

P. A. De Biesbosch 14  
NL-5152 SC Drunen, Netherlands  
Tel: 31-416-690399  
Fax: 31-416-690340

#### United Kingdom

505 Eskdale Road  
Winnersh Triangle  
Wokingham  
Berkshire, England RG41 5TU  
Tel: 44-118-921-5869  
Fax: 44-118-921-5820

07/28/03