



Layout Tips for 12-Bit A/D Converter Application

Author: Bonnie C. Baker
Microchip Technology Inc.

INTRODUCTION

This Application Note originally started as a “cook book” for a true 12-bit layout. The assumption of this type of approach is that a reference design could be provided, which easily could be used for every layout implementation. But, the notion of this approach is fairly unrealistic. There are a multitude of successful ways to layout out systems with 12-bit Analog-to-Digital (A/D) Converters and each layout is highly dependent on the number of devices in the circuit, the types of the devices (digital or analog) and the environment that the final product will reside in. Given all of these variables, it could easily be demonstrated that one successful layout that provides twelve noise free bits from an analog signal may easily fail in another setting.

Because of the complexity of this problem, this Application Note will provide basic guidelines, ending with a review of issues to be aware of. Throughout the application note, examples of good layout and bad layout implementations will be presented. This will be done in the spirit of discussing concepts and not with the intent of recommending one layout as the only one to use.

GETTING A GOOD START

Imagine that the task at hand is to design a pressure sensing circuit that will accurately measure the pressure and present the results on an LCD display screen. Seems easy enough.

The circuit diagram for this system is shown in Figure 1. The pressure sensor that is chosen for the job is a piezo resistive sensor that is configured as a four element bridge. The particular sensor that is selected requires voltage excitation. The full swing output of the sensor is a small (10s of millivolts) differential signal that most appropriately is gained by an operational amplifier structure that also converts the differential output of the sensor to a single ended analog signal. A 12-bit converter is chosen to match the precision of the pressure sensor. Once the converter digitizes the voltage presented at its input, the digital code is sent to a microcontroller. The job of the microcontroller is to perform tasks such as calibration corrections and linearization. Once this is done, the results are sent to the LCD display.

The final step in the circuit development is to work through the calibration and linearization issues associated with the pressure sensor. Once these issues are settled, the microcontroller firmware is developed. Now the board is ready to go to layout.

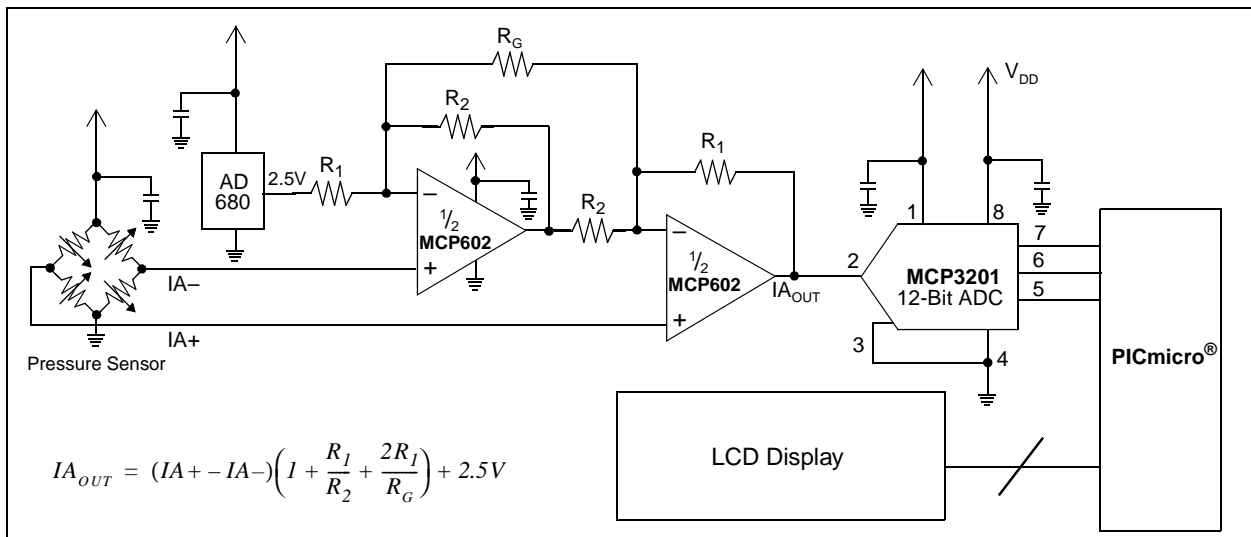

FIGURE 1: This is a pressure sensor application where the differential signal from the sensor is gained by an instrumentation amplifier and digitized with a 12-bit A/D Converter, MCP3201. The results of the conversion is displayed on the LCD display.

ONE MAJOR STEP TOWARDS DISASTER

The size of this circuit seems manageable. So small that one may be tempted to use an auto router layout tool. If this type of tool is used, it should be used carefully. If the tool is capable of implementing restrictions into the layout implementation, the layout design may have a fighting chance. If restrictions are not implemented by the auto routing tool, the best approach is to not use it at all.

GENERAL LAYOUT GUIDELINES

Device Placement

Device placement is critical. In general, there are some noise sensitive devices in this layout and other devices that are major problem creators. Here is a quick way to identify the good, from the bad, from the ugly.

1. Separate the circuit devices into two categories: high speed (>40MHz) and low speed.
2. Separate the above categories into three sub-categories: pure digital, pure analog, and mixed signal.

The board layout strategy should map the diagram shown in Figure 2. Notice the relationship of digital versus analog and high speed versus slower speeds to the board connector.

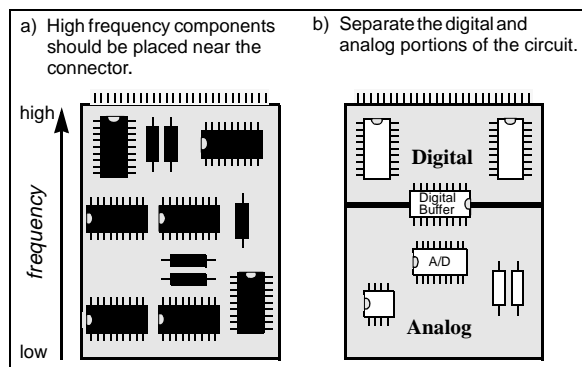

FIGURE 2: The placement of an active component on a PCB is critical in precision 12-bit+ circuits.

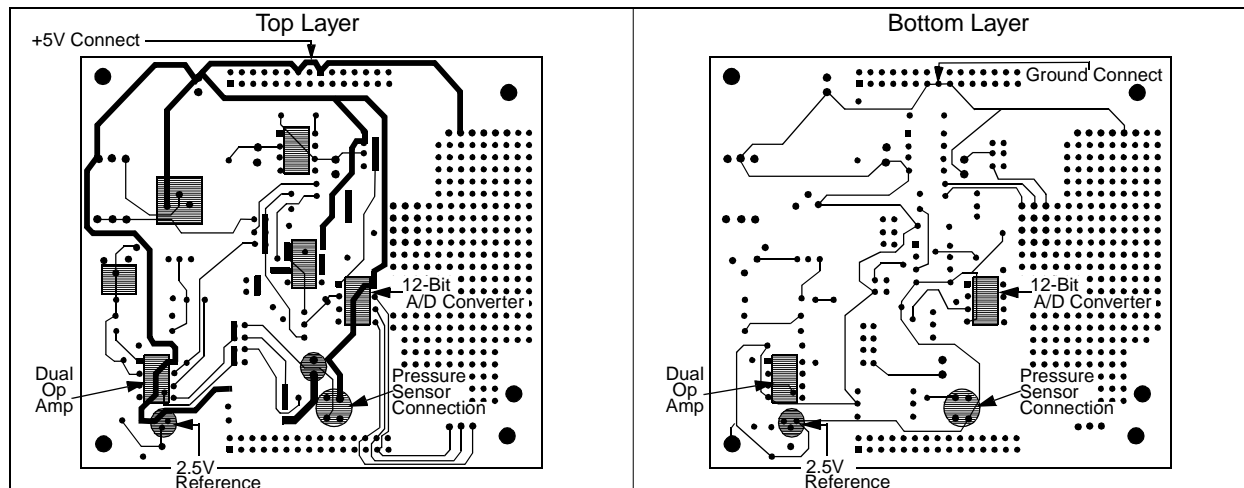

FIGURE 3: Layout of the top and bottom layers of the circuit in Figure 1. Note that this layout does not have a ground or power plane.

In Figure 2b, the digital and analog circuit is shown as being separate from the digital devices, which are closest to the connector or power supply.

The pure analog devices are furthest away for the digital devices to insure that switching noise is not coupled into the analog signal path.

The treatment of the A/D Converter in layout varies from technology to technology. For instance, if the A/D Converter uses a Successive Approximation Register (SAR) design approach, the entire device should be connected to the analog power and ground planes. A common error is to have the converter straddle the analog and digital planes. This strategy may work, but as the accuracy specifications of the A/D Converter improve the digital ground and power plane noise begins to cause problems. For high resolution SAR converters, a digital buffer should be used to isolate the converter from bus activity on the digital side of the circuit.

In contrast, if the A/D Converter is designed using a delta-sigma technology, it should straddle the analog and digital planes. This is due to the fact that the Delta-Sigma Converter is primarily a digital IC.

Ground and Power Supply Strategy

Once the general vicinity of the devices are determined, the ground planes and power planes should be defined. The strategy of the implementation of these planes are a bit tricky.

First of all, assuming that a ground plane is not needed is a dangerous assumption in any circuit with analog and/or mixed signal devices. Ground noise problems are more difficult to deal with than power supply noise problems because analog signals are most typically referenced to ground. For instance, in the circuit shown in Figure 1, the A/D Converter's inverting input pin (MCP3201) is connected to ground. Additionally, the negative side of the pressure sensor is also connected to ground.

A layout for the circuit in Figure 1 is shown in Figure 3. This layout implementation does not have ground or power planes on the board.

With this circuit layout, the controller is dedicated to interfacing with the converter and sending the converter's results to the LCD display. The digital output of the converter over time is shown in Figure 4. This data was collected with no excitation being applied to the sensor.

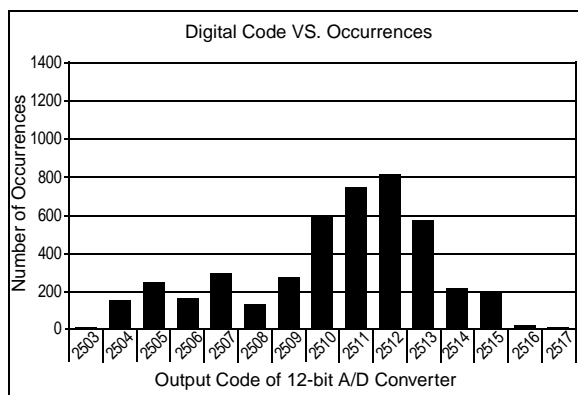

FIGURE 4: This is a histogram of 4096 samples from the output of the A/D Converter from a PCB that does not have a ground or power plane as shown in the PCB layout in Figure 3. The by-pass capacitors are installed.

When determining the grounding strategy of a board, the task at hand should actually be to determine if the circuit can work adequately with just one ground plane or does it need multiple planes.

Figure 5 shows the same layout shown in Figure 3, plus a ground plane. It should be noted that the ground plane has a few breaks due to signal traces. These breaks should be kept to a minimum. Current return paths should not be “pinched” as a consequence of these traces restricting the easy flow of current from the device to the power connector. The histogram for the A/D Converter output is shown in Figure 6. Compared to Figure 4, the output codes are much tighter. The same active devices were used for both tests. The passive devices were different causing a slight offset difference. The noise shown with the A/D Converter digital code is assignable to the op amp noise and the absence of an anti-aliasing filter.

If the circuit has a “minimum” amount of digital circuitry on board, a single ground plane and a single power plane may be appropriate. The qualifier “minimum” is defined by the board designer. The danger of connecting the digital and analog ground planes together is that the analog circuitry can pick-up the noise on the supply pins and couple it into the signal path. In either case, the analog and digital grounds and power supplies should be connected together at one or more points in the circuit to insure that the power supply, input and output ratings of all of the devices are not violated.

The inclusion of a power plane in a 12-bit system is not as critical as the required ground plane. Although a power plane can solve many problems, power noise can be reduced by making the power traces two or three times wider than other traces on the board and by using by-pass capacitors effectively.

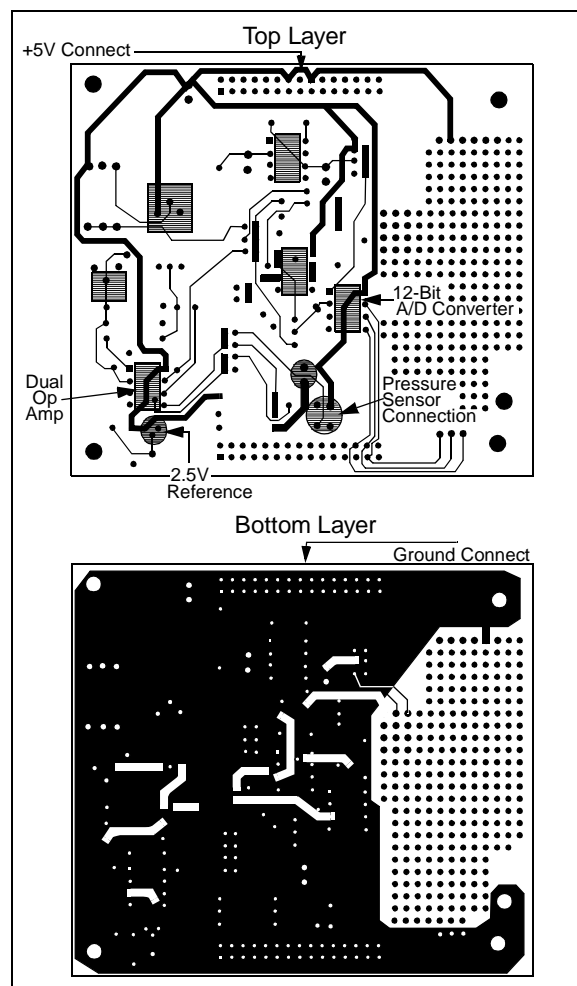

FIGURE 5: Layout of the top and bottom layers of the circuit in Figure 1. Note that this layout DOES have a ground.

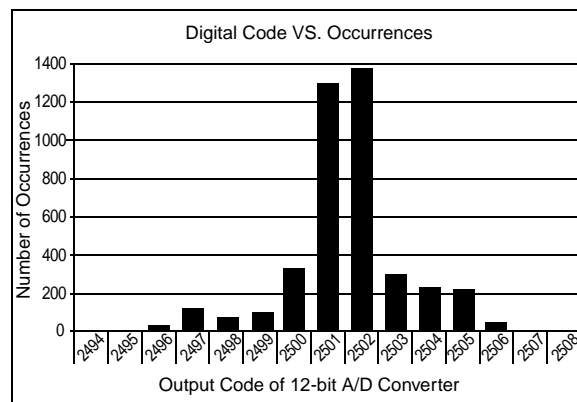

FIGURE 6: This is a histogram of 4096 samples from the output of the A/D Converter on the PCB that has a ground plane as shown in the PCB layout in Figure 5. Note that the power traces are made considerably wider than the signal traces in order to reduce power supply trace inductance. This circuit has all by-pass capacitors installed.

Signal Traces

Generally speaking, the signal traces on the board (both digital and analog) should be as short as possible. This basic guideline will minimize the opportunities for extraneous signals to couple into the signal path.

One area to be particularly cautious of is the input terminals of analog devices. These input terminals normally have a higher impedance than the output or power supply pins. As an example, the voltage reference input pin to the analog to digital converter is most sensitive while a conversion is occurring. With the type of 12-bit converter shown in Figure 1, the input terminals (IN+ and IN-) are also sensitive to injected noise.

Another potential for noise injection into the signal path is the input terminals of an operational amplifier. These terminals have typically 10^9 to $10^{13} \Omega$ input impedance.

These high impedance input terminals are sensitive to injected currents. This can occur if the trace from a high impedance input is next to a trace that has fast changing voltages, such as a digital or clock signal. When a high impedance trace is in close proximity to a trace with these types of voltage changes, charge is capacitively coupled into the high impedance trace.

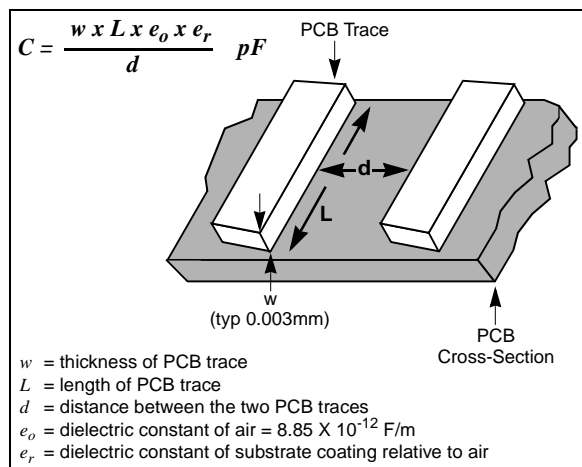

FIGURE 7: A capacitor can be constructed on a PCB by placing two traces in close proximity. With this PCB capacitor, signals can be coupled between the traces.

As shown in Figure 7, the value of the capacitance between two traces is primarily dependent on the distance (d) between the traces and the distance that the two traces are in parallel (L). From this model, the amount of current generated into the high impedance trace is equal to:

$$I = C \delta V / \delta t$$

where

I equals the current that appears on the high impedance trace

C equals the value of capacitance between the two PCB traces

δV equals the change in voltage of the trace that is switching, and

δt equals the amount of time that the voltage change took to get from one level to the next.

DID I SAY BY-PASS?

A good rule concerning by-pass capacitors is to always include them in the circuit. If they are not included, the power supply noise may very well eliminate any chance for 12-bit precision.

By-pass capacitors belong in two locations on the board: one at the power supply ($10\mu\text{F}$ to $100\mu\text{F}$ or both) and one for every active device (digital and analog). The value of the device's by-pass capacitor is dependent on the device in question. If the bandwidth of the device is less than or equal to $\sim 1\text{MHz}$, a $1\mu\text{F}$ will reduce injected noise dramatically. If the bandwidth of the device is above $\sim 10\text{MHz}$, a $0.1\mu\text{F}$ capacitor is probably appropriate. In between these two frequencies, both or either one could be used. Refer to the manufacturer's guidelines for specifics.

Every active device on the board requires a by-pass capacitor. The by-pass capacitor must be placed as close as possible to the power supply pin of the device as shown in Figure 5. If two by-pass capacitors are used for one device, the smaller one should be closest to the device pin. Finally, the lead length of the by-pass capacitor should be as short as possible.

To illustrate the benefits of by-pass capacitors, data is collected from the layout shown in Figure 5, minus the by-pass capacitors. This data is shown in Figure 8.

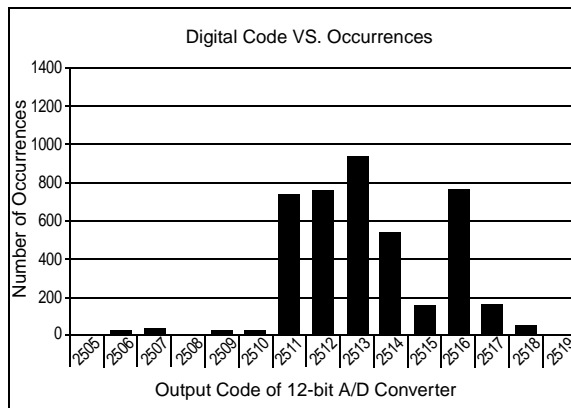

FIGURE 8: This a histogram of 4096 samples from the output of the A/D Converter on the PCB that has a ground plane as shown in the PCB layout in Figure 3. With this circuit implementation, all by-pass capacitors have been removed.

PCB DESIGN CHECK LIST

Good 12-bit layout techniques are not difficult to master as long as a few guidelines are considered.

1. Check device placement versus connectors. Make sure that high speed devices and digital devices are closest to the connector.
2. Always have at least one ground plane in the circuit.
3. Make power traces wider than other traces on the board.
4. Review current return paths and look for possible noise sources on ground connects. This is done by determining the current density at all points of the ground plane and the amount of possible noise present.
5. By-pass all devices properly. Place the capacitors as close to the power pins of the device as possible.
6. Keep all traces as short as possible.
7. Follow all high impedance traces looking for possible capacitive coupling problems from trace to trace.

REFERENCES

Morrison, Ralph, "Noise and Other Interfering Signals", *John Wiley & Sons, Inc.*, 1992

Baker, Bonnie, "Noise Sources in Applications Using Capacitive Coupled Isolated Amplifiers", *AB-047, Burr-Brown Corporation*



WORLDWIDE SALES AND SERVICE

AMERICAS

Corporate Office

Microchip Technology Inc.
2355 West Chandler Blvd.
Chandler, AZ 85224-6199
Tel: 480-786-7200 Fax: 480-786-7277
Technical Support: 480-786-7627
Web Address: <http://www.microchip.com>

Atlanta

Microchip Technology Inc.
500 Sugar Mill Road, Suite 200B
Atlanta, GA 30350
Tel: 770-640-0034 Fax: 770-640-0307

Boston

Microchip Technology Inc.
5 Mount Royal Avenue
Marlborough, MA 01752
Tel: 508-480-9990 Fax: 508-480-8575

Chicago

Microchip Technology Inc.
333 Pierce Road, Suite 180
Itasca, IL 60143
Tel: 630-285-0071 Fax: 630-285-0075

Dallas

Microchip Technology Inc.
4570 Westgrove Drive, Suite 160
Addison, TX 75248
Tel: 972-818-7423 Fax: 972-818-2924

Dayton

Microchip Technology Inc.
Two Prestige Place, Suite 150
Miamisburg, OH 45342
Tel: 937-291-1654 Fax: 937-291-9175

Detroit

Microchip Technology Inc.
Tri-Atria Office Building
32255 Northwestern Highway, Suite 190
Farmington Hills, MI 48334
Tel: 248-538-2250 Fax: 248-538-2260

Los Angeles

Microchip Technology Inc.
18201 Von Karman, Suite 1090
Irvine, CA 92612
Tel: 949-263-1888 Fax: 949-263-1338

New York

Microchip Technology Inc.
150 Motor Parkway, Suite 202
Hauppauge, NY 11788
Tel: 631-273-5305 Fax: 631-273-5335

San Jose

Microchip Technology Inc.
2107 North First Street, Suite 590
San Jose, CA 95131
Tel: 408-436-7950 Fax: 408-436-7955

AMERICAS (continued)

Toronto

Microchip Technology Inc.
5925 Airport Road, Suite 200
Mississauga, Ontario L4V 1W1, Canada
Tel: 905-405-6279 Fax: 905-405-6253

ASIA/PACIFIC

Hong Kong

Microchip Asia Pacific
Unit 2101, Tower 2
Metroplaza
223 Hing Fong Road
Kwai Fong, N.T., Hong Kong
Tel: 852-2-401-1200 Fax: 852-2-401-3431

Beijing

Microchip Technology, Beijing
Unit 915, 6 Chaoyangmen Bei Dajie
Dong Erhuan Road, Dongcheng District
New China Hong Kong Manhattan Building
Beijing 100027 PRC
Tel: 86-10-85282100 Fax: 86-10-85282104

India

Microchip Technology Inc.
India Liaison Office
No. 6, Legacy, Convent Road
Bangalore 560 025, India
Tel: 91-80-229-0061 Fax: 91-80-229-0062

Japan

Microchip Technology Intl. Inc.
Benex S-1 6F
3-18-20, Shinyokohama
Kohoku-Ku, Yokohama-shi
Kanagawa 222-0033 Japan
Tel: 81-45-471-6166 Fax: 81-45-471-6122

Korea

Microchip Technology Korea
168-1, Youngbo Bldg. 3 Floor
Samsung-Dong, Kangnam-Ku
Seoul, Korea
Tel: 82-2-554-7200 Fax: 82-2-558-5934

Shanghai

Microchip Technology
RM 406 Shanghai Golden Bridge Bldg.
2077 Yan'an Road West, Hong Qiao District
Shanghai, PRC 200335
Tel: 86-21-6275-5700 Fax: 86 21-6275-5060

ASIA/PACIFIC (continued)

Singapore

Microchip Technology Singapore Pte Ltd.
200 Middle Road
#07-02 Prime Centre
Singapore 188980
Tel: 65-334-8870 Fax: 65-334-8850

Taiwan, R.O.C

Microchip Technology Taiwan
10F-1C 207
Tung Hua North Road
Taipei, Taiwan, ROC
Tel: 886-2-2717-7175 Fax: 886-2-2545-0139

EUROPE

United Kingdom

Arizona Microchip Technology Ltd.
505 Eskdale Road
Wokingham
Berkshire, England RG41 5TU
Tel: 44 118 921 5858 Fax: 44-118 921-5835

Denmark

Microchip Technology Denmark ApS
Regus Business Centre
Lautrup hof 1-3
Ballerup DK-2750 Denmark
Tel: 45 4420 9895 Fax: 45 4420 9910

France

Arizona Microchip Technology SARL
Parc d'Activite du Moulin de Massy
43 Rue du Saule Trapu
Batiment A - 1er Etage
91300 Massy, France
Tel: 33-1-69-53-63-20 Fax: 33-1-69-30-90-79

Germany

Arizona Microchip Technology GmbH
Gustav-Heinemann-Ring 125
D-81739 München, Germany
Tel: 49-89-627-144 0 Fax: 49-89-627-144-44

Italy

Arizona Microchip Technology SRL
Centro Direzionale Colleoni
Palazzo Taurus 1 V. Le Colleoni 1
20041 Agrate Brianza
Milan, Italy
Tel: 39-039-65791-1 Fax: 39-039-6899883

11/15/99

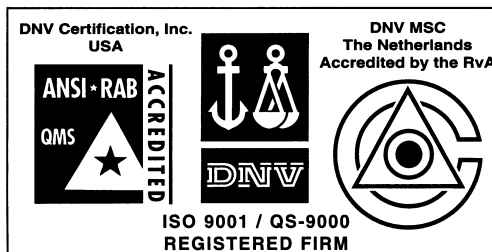

Microchip received QS-9000 quality system certification for its worldwide headquarters, design and water fabrication facilities in Chandler and Tempe, Arizona in July 1999. The Company's quality system processes and procedures are QS-9000 compliant for its PICmicro® 8-bit MCUs, KEELOC® code hopping devices, Serial EEPROMs and microperipheral products. In addition, Microchip's quality system for the design and manufacture of development systems is ISO 9001 certified.

All rights reserved. © 1999 Microchip Technology Incorporated. Printed in the USA. 11/99 Printed on recycled paper.

Information contained in this publication regarding device applications and the like is intended for suggestion only and may be superseded by updates. No representation or warranty is given and no liability is assumed by Microchip Technology Incorporated with respect to the accuracy or use of such information, or infringement of patents or other intellectual property rights arising from such use or otherwise. Use of Microchip's products as critical components in life support systems is not authorized except with express written approval by Microchip. No licenses are conveyed, implicitly or otherwise, under any intellectual property rights. The Microchip logo and name are registered trademarks of Microchip Technology Inc. in the U.S.A. and other countries. All rights reserved. All other trademarks mentioned herein are the property of their respective companies.