

# DATA SHEET

## **TDA8552T; TDA8552TS** **2 × 1.4 W BTL audio amplifiers with digital volume control and headphone sensing**

Preliminary specification  
Supersedes data of 1998 Feb 26  
File under Integrated Circuits, IC01

1998 Jun 02

## 2 × 1.4 W BTL audio amplifiers with digital volume control and headphone sensing

## TDA8552T; TDA8552TS

### FEATURES

- One pin digital volume control (for each channel)
- Volume setting with up/down pulses
- Auto repeat function on volume setting
- Headphone sensing
- Maximum gain set by selection pin
- Low sensitivity for EMC radiation
- Internal feedback resistors
- Flexibility in use
- Few external components
- Low saturation voltage of output stage
- Standby mode controlled by CMOS compatible levels
- Low standby current
- No switch-on/switch-off plops
- High supply voltage ripple rejection
- Protected against electrostatic discharge
- Outputs short-circuit safe to ground,  $V_{DD}$  and across the load
- Thermally protected.

### APPLICATIONS

- Portable consumer products
- Notebook computers
- Communication equipment.

### ORDERING INFORMATION

TYPE NUMBER	PACKAGE		
	NAME	DESCRIPTION	VERSION
TDA8552T	SO20	plastic small outline package; 20 leads; body width 7.5 mm	SOT163-1
TDA8552TS	SSOP20	plastic shrink small outline package; 20 leads; body width 4.4 mm	SOT266-1

### GENERAL DESCRIPTION

The TDA8552T is a two channel audio power amplifier that provides an output power of  $2 \times 1.4$  W into an  $8 \Omega$  load using a 5 V power supply. The circuit contains two BTL power amplifiers, two digital volume controls and standby/mute logic. Volume and balance of the amplifiers are controlled using two digital input pins which can be driven by simple push-buttons or by a microcontroller.

Using the selection pin (GAINSEL) the maximum gain can be set at 20 or 30 dB. The headphone sense input (HPS) can be used to detect if a headphone is plugged into the jack connector. If a headphone is plugged into the jack connector the amplifier switches from the BTL to the SE mode and the BTL loudspeakers are switched off. This also results in a reduction of quiescent current consumption.

The TDA8552T is contained in a 20-pin small outline package. For the TDA8552TS, which is contained in a 20-pin very small outline package, the maximum output power is limited by the maximum allowed ambient temperature. More information can be found in Section "Thermal design considerations". The SO20 package has the four corner leads connected to the die pad so that the thermal behaviour can be improved by the PCB layout.

**2 × 1.4 W BTL audio amplifiers with digital  
volume control and headphone sensing**

**TDA8552T; TDA8552TS**

**QUICK REFERENCE DATA**

SYMBOL	PARAMETER	CONDITIONS	MIN.	TYP.	MAX.	UNIT
$V_{DD}$	supply voltage		2.7	5	5.5	V
$I_q$	quiescent supply current	BTL mode; $V_{DD} = 5\text{ V}$	–	14	20	mA
		BTL mode; $V_{DD} = 3.3\text{ V}$	–	10	15	mA
		SE mode; $V_{DD} = 5\text{ V}$	–	8.5	12	mA
		SE mode; $V_{DD} = 3.3\text{ V}$	–	5	8	mA
$I_{stb}$	standby current		–	1	10	$\mu\text{A}$
$P_o$	output power	THD = 10%; $R_L = 8\ \Omega$ ; $V_{DD} = 5\text{ V}$	1	1.4	–	W
$G_v$	voltage gain	low gain; maximum volume	–	20	–	dB
		low gain; minimum volume	–	–60	–	dB
		high gain; maximum volume	–	30	–	dB
		high gain; minimum volume	–	–50	–	dB
$N_{step}$	number of volume steps		–	64	–	
THD	total harmonic distortion	$P_o = 0.5\text{ W}$	–	0.1	–	%
SVRR	supply voltage ripple rejection		50	–	–	dB

# 2 × 1.4 W BTL audio amplifiers with digital volume control and headphone sensing

## TDA8552T; TDA8552TS

### BLOCK DIAGRAM

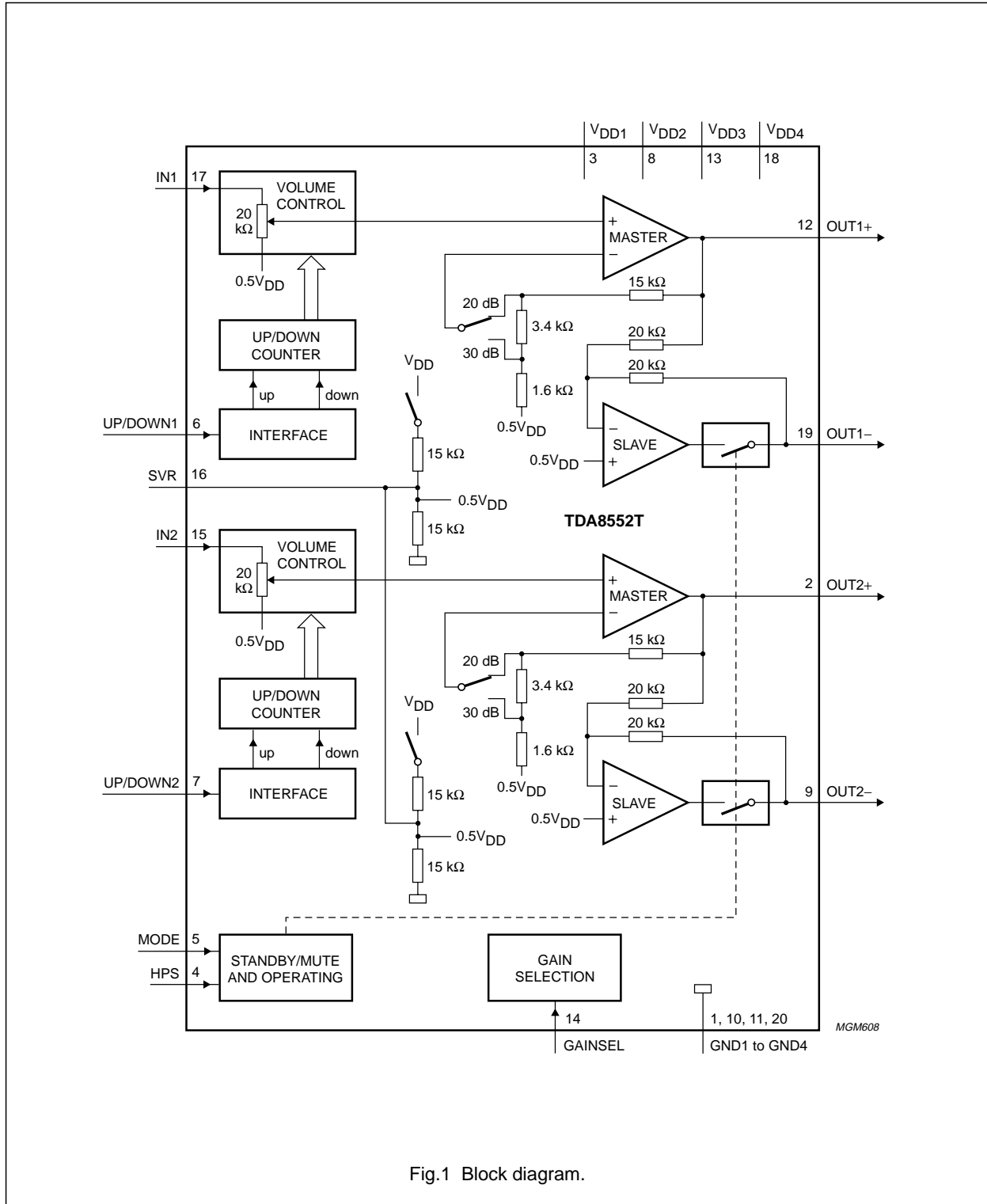

Fig.1 Block diagram.

## 2 × 1.4 W BTL audio amplifiers with digital volume control and headphone sensing

### TDA8552T; TDA8552TS

#### PINNING

SYMBOL	PIN <sup>(1)</sup>	DESCRIPTION
GND1	1	ground 1, substrate/leadframe
OUT2+	2	positive loudspeaker terminal output channel 2
V <sub>DD1</sub>	3	supply voltage 1
HPS	4	digital input for headphone sensing
MODE	5	digital trinary input for mode selection (standby, mute and operating)
UP/DOWN1	6	digital trinary input for volume control channel 1
UP/DOWN2	7	digital trinary input for volume control channel 2
V <sub>DD2</sub>	8	supply voltage 2
OUT2-	9	negative loudspeaker terminal output channel 2
GND2	10	ground 2, substrate/leadframe
GND3	11	ground 3, substrate/leadframe
OUT1+	12	positive loudspeaker terminal output channel 1
V <sub>DD3</sub>	13	supply voltage 3
GAINSEL	14	digital input for gain selection
IN2	15	audio input channel 2
SVR	16	half supply voltage, decoupling ripple rejection
IN1	17	audio input channel 1
V <sub>DD4</sub>	18	supply voltage 4
OUT1-	19	negative loudspeaker terminal output channel 1
GND4	20	ground 4, substrate/leadframe

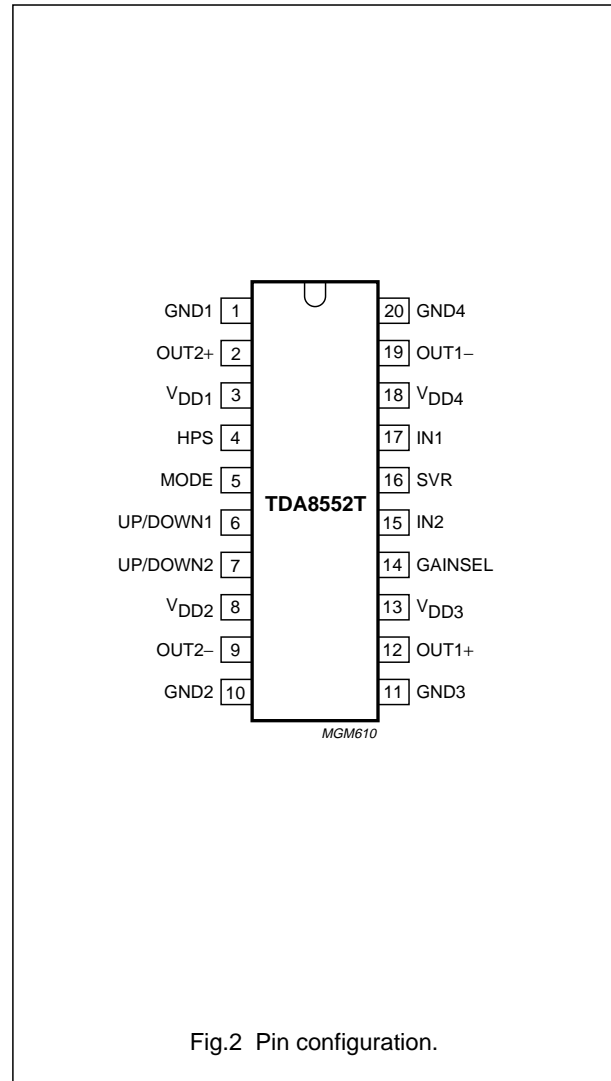

Fig.2 Pin configuration.

#### Note

- For the SO20 (SOT163-1) package only: the ground pins 1, 10, 11 and 20 are mechanically connected to the leadframe and electrically to the substrate of the die. On the PCB the ground pins can be connected to a copper area to decrease the thermal resistance.

## 2 × 1.4 W BTL audio amplifiers with digital volume control and headphone sensing

## TDA8552T; TDA8552TS

### FUNCTIONAL DESCRIPTION

The TDA8552T is a 2 × 1.4 W BTL audio power amplifier capable of delivering 2 × 1.4 W output power into an 8 Ω load at THD = 10% using a 5 V power supply. The gain of the amplifier can be set by the digital volume control.

The gain in the maximum volume setting is 20 dB (low gain) or 30 dB (high gain). This maximum gain can be selected by the gain selection pin. The headphone sense input (HPS) can be used to detect if a headphone is plugged into the jack connector. If a headphone is plugged into the jack connector the amplifier switches from the BTL to the SE mode and the BTL loudspeakers are switched off. This also results in a reduction of quiescent current consumption. Using the MODE pin the device can be switched to the standby condition, the mute condition or the normal operating condition. The device is protected by an internal thermal shutdown protection mechanism.

### Power amplifier

The power amplifier is a Bridge-Tied Load (BTL) amplifier with a complementary CMOS output stage. The total voltage loss for both output power MOS transistors is within 1 V and with a 5 V supply and an 8 Ω loudspeaker an output power of 1.4 W can be delivered. The total gain of this power amplifier can be set at 20 or 30 dB by the gain selection pin.

### Gain selection

The gain selection can be used for a fixed gain setting, depending on the application. The gain selection pin must be hard wired to ground (20 dB) or to  $V_{DD}$  (30 dB). Gain selecting during the operation is not advised, switching is not guaranteed plop free.

### Input attenuator

The volume control operates as a digitally controlled input attenuator between the audio input pin and the power amplifier. In the maximum volume control setting the attenuation is 0 dB and in the minimum volume control setting the typical attenuation is 80 dB. The attenuation can be set in 64 steps by the UP/DOWN pin. Both attenuators for channels 1 and 2 are separated from each other and are controlled by their own UP/DOWN pin. Balance control can be arranged by applying UP/DOWN pulses only on pins 6 and 7, see Fig.5.

### Volume control

Each attenuator is controlled with its own UP/DOWN pin (ternary input):

- Floating UP/DOWN pin: volume remains unchanged
- Negative pulses: decreasing volume
- Positive pulses: increasing volume.

Each pulse on the UP/DOWN pin results in a change in gain of  $\frac{80}{64} = 1.25$  dB (typical value).

In the basic application the UP/DOWN pin is switched to ground or  $V_{DD}$  by a double push-button. When the supply voltage is initially connected, after a complete removal of the supply, the initial state of the volume control is an attenuation of 40 dB (low volume), so the gain of the total amplifier is -20 dB in the low gain setting or -10 dB in the high gain setting. After powering-up, some positive pulses have to be applied to the UP/DOWN pin for turning up to listening volume.

### Auto repeat

If the UP/DOWN pin is LOW or HIGH for the wait time ( $t_{wait}$  in seconds) (one of the keys is pressed) then the device starts making up or down pulses by itself with a frequency

given by  $\frac{1}{t_{rep}}$  (repeat function).

The wait time and the repeat frequency are set using an internal RC oscillator with an accuracy of ±10%.

### Volume settings in standby mode

When the device is switched with the MODE select pin to the mute or the standby condition, the volume control attenuation setting keeps its value, under the assumption that the voltage on the  $V_{DD}$  pin does not fall below the minimum supply voltage. After switching the device back to the operation mode, the previous volume setting is maintained. In the standby mode the volume setting is maintained as long as the minimum supply voltage is available. The current consumption is very low, approximately 1 μA (typ.). In battery fed applications the volume setting can be maintained during battery exchange if there is a supply capacitor available.

---

## 2 × 1.4 W BTL audio amplifiers with digital volume control and headphone sensing

---

## TDA8552T; TDA8552TS

### Mode select pin

The device is in the standby mode (with a very low current consumption) if the voltage at the MODE pin is between  $V_{DD}$  and  $V_{DD} - 0.5$  V. At a mode select voltage level of less than 0.5 V the amplifier is fully operational. In the range between 1 V and  $V_{DD} - 1$  V the amplifier is in the mute condition. The mute condition is useful for using it as a 'fast mute', in this mode the output signal is suppressed, while the volume setting remains at its value. It is advised to keep the device in the mute condition while the input capacitor is being charged. This can be achieved by holding the MODE pin at a level of  $0.5V_{DD}$ , or by waiting approximately 100 ms before giving the first volume-UP pulses.

### Headphone sense pin (HPS)

A headphone can be connected to the amplifier by using a coupling capacitor for each channel. The common ground pin of the headphone is connected to the ground of the amplifier, see Fig.4. By using the HPS pin as illustrated in Fig.4, the TDA8552T detects if a headphone jack plug is inserted into the connector.

When no headphone is plugged in, the voltage level at the HPS pin will remain LOW. A voltage less than  $V_{DD} - 1$  V at the HPS pin will keep the device in the BTL mode, thus the loudspeakers can be operational. If the HPS pin is not connected then the device will remain in the BTL mode.

When a headphone is plugged into the connector, the voltage at the HPS pin will be set to  $V_{DD}$ . The device then switches to the Single-Ended (SE) mode, this means that the slave power amplifiers at the outputs OUT1– and OUT2– will be switched to the standby mode. This results in floating outputs OUT1– and OUT2–, the loudspeaker signal is thus attenuated by approximately 80 dB and only the headphone can operate.

One of the benefits of this system is that the loudspeaker current does not flow through the jack connector switch, which could give some output power loss. The other benefit is that the quiescent current is reduced when the headphone jack is inserted.

## 2 × 1.4 W BTL audio amplifiers with digital volume control and headphone sensing

## TDA8552T; TDA8552TS

### LIMITING VALUES

In accordance with the Absolute Maximum Rating System (IEC 134).

SYMBOL	PARAMETER	CONDITIONS	MIN.	MAX.	UNIT
$V_{DD}$	supply voltage	operating	-0.3	+5.5	V
$V_i$	input voltage		-0.3	$V_{DD} + 0.3$	V
$I_{ORM}$	repetitive peak output current		-	1	A
$T_{stg}$	storage temperature		-55	+150	°C
$T_{amb}$	operating ambient temperature		-40	+85	°C
$V_{sc}$	AC and DC short-circuit safe voltage		-	5.5	V
$P_{tot}$	maximum power dissipation	SO20	-	2.2	W
		SSOP20	-	1.1	W

### THERMAL CHARACTERISTICS

See Section "Thermal design considerations" in Chapter "Test and application information".

SYMBOL	PARAMETER	CONDITIONS	VALUE	UNIT
$R_{th(j-a)}$	thermal resistance from junction to ambient for the TDA8552T (SO20)	in free air	60	K/W
		extra copper	55	K/W
	for the TDA8552TS (SSOP20)	in free air	110	K/W
		extra copper	80	K/W

**Table 1** Power rating; note 1

$V_{DD}$ (V)	$R_L$ ( $\Omega$ )	$P_o$ (W) THD = 10%	OPERATION	MUSIC POWER		
				$P_{max}$ (W)	$T_{amb(max)}$ (°C)	
					SO20	SSOP20
3.3	4	0.9	BTL	0.55	120	106
3.3	8	0.6	BTL	0.28	134	127
3.3	16	0.3	BTL	0.14	142	139
3.3	32SE	0.035	headphone	0.03	150	150
5.0	4	2.0	BTL	1.25	81	50
5.0	8	1.4	BTL	0.65	114	98
5.0	16	0.8	BTL	0.32	132	124
5.0	32SE	0.09	headphone	0.07	146	144
continuous sine wave						
3.3	4	0.9	BTL	1.1	89	62
5	8	1.4	BTL	1.25	81	50

### Note

- The power rating is based on  $R_{th(j-a)}$  with recommended copper pattern of at least  $4 \times 1 \text{ cm}^2$  to the corner leads and copper under the IC package.



## 2 × 1.4 W BTL audio amplifiers with digital volume control and headphone sensing

## TDA8552T; TDA8552TS

### QUALITY SPECIFICATION

Quality specification in accordance with “SNW-FQ-611 part E”, if this type is used as an audio amplifier.

### DC CHARACTERISTICS

$V_{DD} = 5\text{ V}$ ;  $T_{amb} = 25\text{ °C}$ ;  $R_L = 8\ \Omega$ ;  $V_{MODE} = 0\text{ V}$ ; total gain setting at 7 dB; according to Fig.4.; unless otherwise specified.

SYMBOL	PARAMETER	CONDITIONS	MIN.	TYP.	MAX.	UNIT
$V_{DD}$	supply voltage		2.7	5	5.5	V
$I_{DD}$	supply current	BTL mode; $V_{DD} = 5\text{ V}$ ; $R_L = \infty$ ; note 1	–	14	20	mA
		SE mode; $V_{DD} = 5\text{ V}$	–	8.5	12	mA
		BTL mode; $V_{DD} = 3.3\text{ V}$ ; $R_L = \infty$ ; note 1	–	10	15	mA
		SE mode; $V_{DD} = 3.3\text{ V}$	–	5	8	mA
$I_{stb}$	standby current	$V_{MODE} = V_{DD}$	–	1	10	$\mu\text{A}$
$V_O$	DC output voltage	note 2	–	2.5	–	V
$ V_{OUT+} - V_{OUT-} $	differential output offset voltage	GAINSEL = 0 V	–	–	50	mV
		GAINSEL = $V_{DD}$	–	–	150	mV
<b>Mode select pin</b>						
$V_{MODE}$	input voltage	standby	$V_{DD} - 0.5$	–	$V_{DD}$	V
		mute	1	–	$V_{DD} - 1.4$	V
		operating	0	–	0.5	V
$I_{MODE}$	input current	$0 < V_{MODE} < V_{DD}$	–	–	1	$\mu\text{A}$
$\alpha_{mute}$	mute attenuation	note 3	80	tbf	–	dB
<b>Gain select pin</b>						
$V_{GAINSEL}$	input voltage	low gain (20 dB)	0	–	0.6	V
		high gain (30 dB)	4.1	–	$V_{DD}$	V
$I_{GAINSEL}$	input current		–	–	1	$\mu\text{A}$
<b>Headphone sense pin</b>						
$V_{HPS}$	input voltage	SE mode; headphone detected	$V_{DD} - 1$	–	$V_{DD}$	V
$I_{HPS}$	input current		–	–	1	$\mu\text{A}$

## 2 × 1.4 W BTL audio amplifiers with digital volume control and headphone sensing

TDA8552T; TDA8552TS

SYMBOL	PARAMETER	CONDITIONS	MIN.	TYP.	MAX.	UNIT
<b>Volume control</b>						
$t_W$	pulse width		50	–	–	ns
$t_{rep}$	pulse repetition time		100	–	–	ns
$V_{th(up)}$	UP/DOWN pin UP threshold level		4.1	–	$V_{DD}$	V
$V_{float(max)}$	UP/DOWN pin floating high level		–	–	3.4	V
$V_{float(min)}$	UP/DOWN pin floating low level		1.0	–	–	V
$V_{th(down)}$	UP/DOWN pin DOWN threshold level		0	–	0.6	V
$I_{l(up/down)}$	input current UP/DOWN pin	$0 < V_{UP/DOWN} < V_{DD}$	–	–	200	$\mu A$
$t_{wait}$	auto repeat wait time		–	500	–	ms
$t_{rep}$	repeat time	key pressed	–	130	–	ms
<b>Volume attenuator</b>						
$G_{v(l)}$	low gain; maximum volume (including power amplifier)		19	20	21	dB
	low gain; minimum volume (including power amplifier)		tbf	–60	tbf	dB
$G_{v(h)}$	high gain; maximum volume (including power amplifier)		29	30	31	dB
	high gain; minimum volume (including power amplifier)		tbf	–50	tbf	dB
$N_{step}$	number of gain steps		–	64	–	
$\Delta G_v$	variation of gain per step		–	1.25	–	dB
$Z_i$	input impedance		14	20	–	k $\Omega$
$V_{i(max)(rms)}$	maximum input voltage (RMS value)		–	–	1.75	V

**Notes**

- With a load connected at the outputs the quiescent current will increase, the maximum of this increase being equal to  $2 \times \left( \frac{\text{DC output offset voltage}}{R_L} \right)$
- The DC output voltage with respect to ground is approximately  $0.5V_{DD}$ .
- Output voltage in mute position is measured with an input of 1 V (RMS) in a bandwidth of 20 kHz, so including noise, gain select pin is LOW (0 V).

## 2 × 1.4 W BTL audio amplifiers with digital volume control and headphone sensing

## TDA8552T; TDA8552TS

### AC CHARACTERISTICS ( $V_{DD} = 3.3 \text{ V}$ )

$T_{amb} = 25 \text{ }^\circ\text{C}$ ;  $R_L = 8 \text{ } \Omega$ ;  $f = 1 \text{ kHz}$ ; total gain setting at 7 dB;  $V_{MODE} = 0 \text{ V}$ ; gain select pin is at 0 V (maximum gain = 20 dB); according to Fig.4.

SYMBOL	PARAMETER	CONDITIONS	MIN.	TYP.	MAX.	UNIT
$P_o$	output power	THD = 10%; $R_L = 4 \text{ } \Omega$	–	0.9	–	W
		THD = 10%; $R_L = 8 \text{ } \Omega$	–	0.6	–	W
		THD = 10%; $R_L = 16 \text{ } \Omega$	–	0.3	–	W
		THD = 0.5%; $R_L = 4 \text{ } \Omega$	–	0.6	–	W
		THD = 0.5%; $R_L = 8 \text{ } \Omega$	–	0.4	–	W
		THD = 0.5%; $R_L = 16 \text{ } \Omega$	–	0.2	–	W
THD	total harmonic distortion	$P_o = 0.1 \text{ W}$ ; note 1	–	0.1	–	%
$V_{o(n)}$	noise output voltage	note 2	–	60	–	$\mu\text{V}$
SVRR	supply voltage ripple rejection	note 3	tbf	55	–	dB
$V_{i(max)}$	maximum input voltage	THD = 1%; $G_V = -50 \text{ to } 0 \text{ dB}$	–	–	1.1	V
$\alpha_{sup}$	channel suppression	$V_{HPS} = V_{DD}$ ; note 4	–	80	–	dB
$\alpha_{cs}$	channel separation		–	55	–	dB

### Notes

- Volume setting at maximum.
- The noise output voltage is measured at the output in a frequency band from 20 Hz to 20 kHz (unweighted),  $R_{source} = 0 \text{ } \Omega$ , gain select pin is LOW (0 V).
- Supply voltage ripple rejection is measured at the output, with a source impedance of  $R_{source} = 0 \text{ } \Omega$  at the input. The ripple voltage is a sine wave with a frequency of 1 kHz and an amplitude of 100 mV (RMS) is applied to the positive supply rail, gain select pin is LOW (0 V).
- Channel suppression is measured at the output with a source impedance of  $R_{source} = 0 \text{ } \Omega$  at the input and a frequency of 1 kHz. The output level in the operating single-ended channel (OUT+) is set at 2 V (RMS).

## 2 × 1.4 W BTL audio amplifiers with digital volume control and headphone sensing

## TDA8552T; TDA8552TS

### AC CHARACTERISTICS ( $V_{DD} = 5\text{ V}$ )

$T_{amb} = 25\text{ °C}$ ;  $R_L = 8\ \Omega$ ;  $f = 1\text{ kHz}$ ; total gain setting at 7 dB;  $V_{MODE} = 0\text{ V}$ ; Gain select pin is at 0 V (maximum gain = 20 dB); according to Fig.4; package is SO20.

SYMBOL	PARAMETER	CONDITIONS	MIN.	TYP.	MAX.	UNIT
$P_o$	output power	THD = 10%; $R_L = 8\ \Omega$	1.0	1.4	–	W
		THD = 10%; $R_L = 16\ \Omega$	–	0.8	–	W
		THD = 0.5%; $R_L = 8\ \Omega$	0.6	1.0	–	W
		THD = 0.5%; $R_L = 16\ \Omega$	–	0.6	–	W
THD	total harmonic distortion	$P_o = 0.1\text{ W}$ ; note 1	–	0.15	0.4	%
		$P_o = 0.5\text{ W}$ ; note 1	–	0.1	0.3	%
$V_{o(n)}$	noise output voltage	GAINSEL. = 0 V; note 2	–	60	100	$\mu\text{V}$
		GAINSEL. = $V_{DD}$ ; note 2	–	100	–	$\mu\text{V}$
SVRR	supply voltage ripple rejection	note 3	50	55	–	dB
$V_{i(max)}$	a maximum input voltage	THD = 1%; $G_V = -50\text{ to }0\text{ dB}$	–	–	1.75	V
$\alpha_{sup}$	channel suppression	$V_{HPS} = V_{DD}$ ; note 4	70	80	–	dB
$\alpha_{cs}$	channel separation		50	–	–	dB

### Notes

- Volume setting at maximum.
- The noise output voltage is measured at the output in a frequency band from 20 Hz to 20 kHz (unweighted),  $R_{source} = 0\ \Omega$ .
- Supply voltage ripple rejection is measured at the output, with a source impedance of  $R_{source} = 0\ \Omega$  at the input. The ripple voltage is a sine wave with a frequency of 1 kHz and an amplitude of 100 mV (RMS) is applied to the positive supply rail, gain select pin is LOW (0 V).
- Channel suppression is measured at the output with a source impedance of  $R_{source} = 0\ \Omega$  at the input and a frequency of 1 kHz. The output level in the operating single-ended channel (OUT+) is set at 1 V (RMS).

## 2 × 1.4 W BTL audio amplifiers with digital volume control and headphone sensing

TDA8552T; TDA8552TS

### AC CHARACTERISTICS (FOR HEADPHONE; $R_L = 32 \Omega$ ; CONNECTED SE)

$V_{DD} = 5 \text{ V}$ ;  $T_{amb} = 25 \text{ }^\circ\text{C}$ ;  $f = 1 \text{ kHz}$ ; total gain setting at 20 dB;  $V_{MODE} = 0 \text{ V}$ ; gain select pin is 0 V (maximum gain = 20 dB); according to Fig.4.

SYMBOL	PARAMETER	CONDITIONS	MIN.	TYP.	MAX.	UNIT
$P_o$	output power	THD = 10%; $V_{DD} = 3.3 \text{ V}$	–	35	–	mW
		THD = 10%; $V_{DD} = 5.0 \text{ V}$	–	90	–	mW
		THD = 0.5%; $V_{DD} = 3.3 \text{ V}$	–	25	–	mW
		THD = 0.5%; $V_{DD} = 5.0 \text{ V}$	–	60	–	mW
THD	total harmonic distortion	$P_o = 60 \text{ mW}$	–	0.04	–	%
$V_{o(n)}$	noise output voltage	note 1	–	60	100	$\mu\text{V}$
SVRR	supply voltage ripple rejection	note 2	50	55	–	dB
$V_{i(max)}$	maximum input voltage	THD = 1%; $G_v = -50 \text{ to } 0 \text{ dB}$	–	–	1.75	V
$\alpha_{cs}$	channel separation		50	–	–	dB

#### Notes

- The noise output voltage is measured at the output in a frequency band from 20 Hz to 20 kHz (unweighted),  $R_{source} = 0 \Omega$ , gain select pin is LOW (0 V).
- Supply voltage ripple rejection is measured at the output, with a source impedance of  $R_{source} = 0 \Omega$  at the input. The ripple voltage is a sine wave with a frequency of 1 kHz and an amplitude of 100 mV (RMS) is applied to the positive supply rail, gain select pin is LOW (0 V).

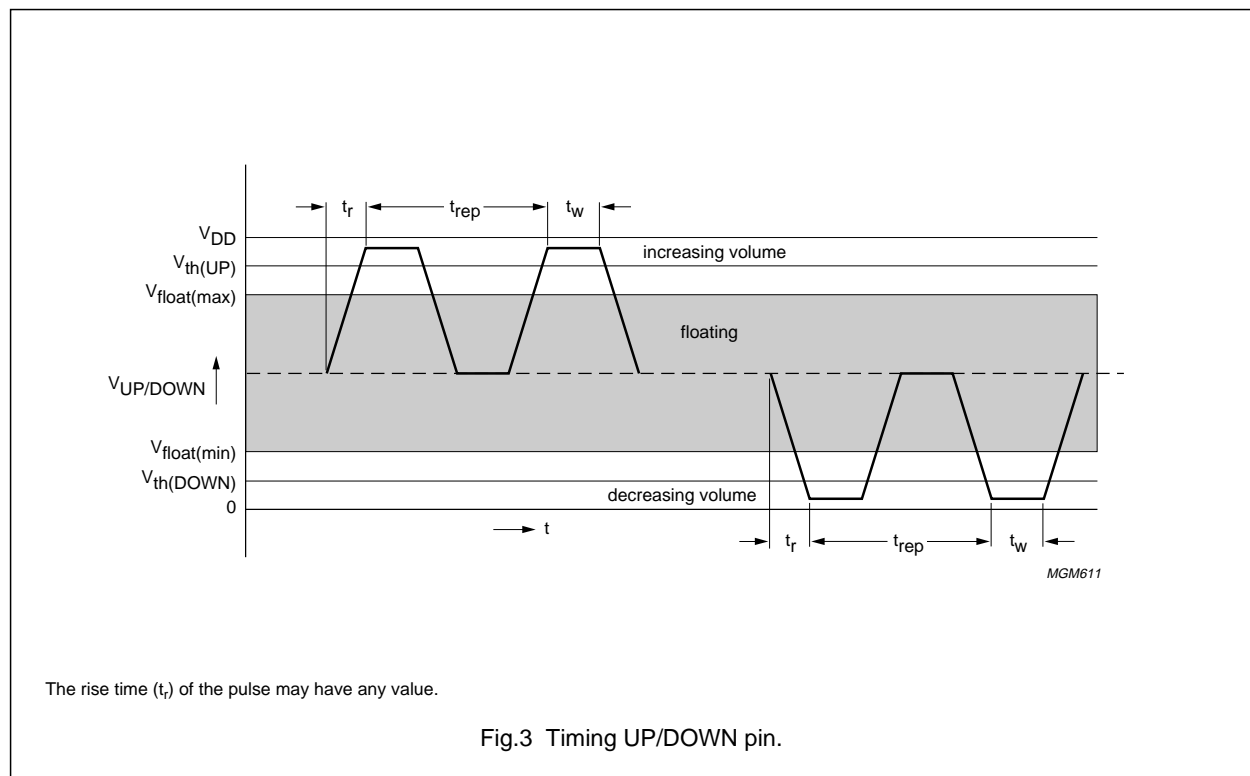

# 2 × 1.4 W BTL audio amplifiers with digital volume control and headphone sensing

## TDA8552T; TDA8552TS

### TEST AND APPLICATION INFORMATION

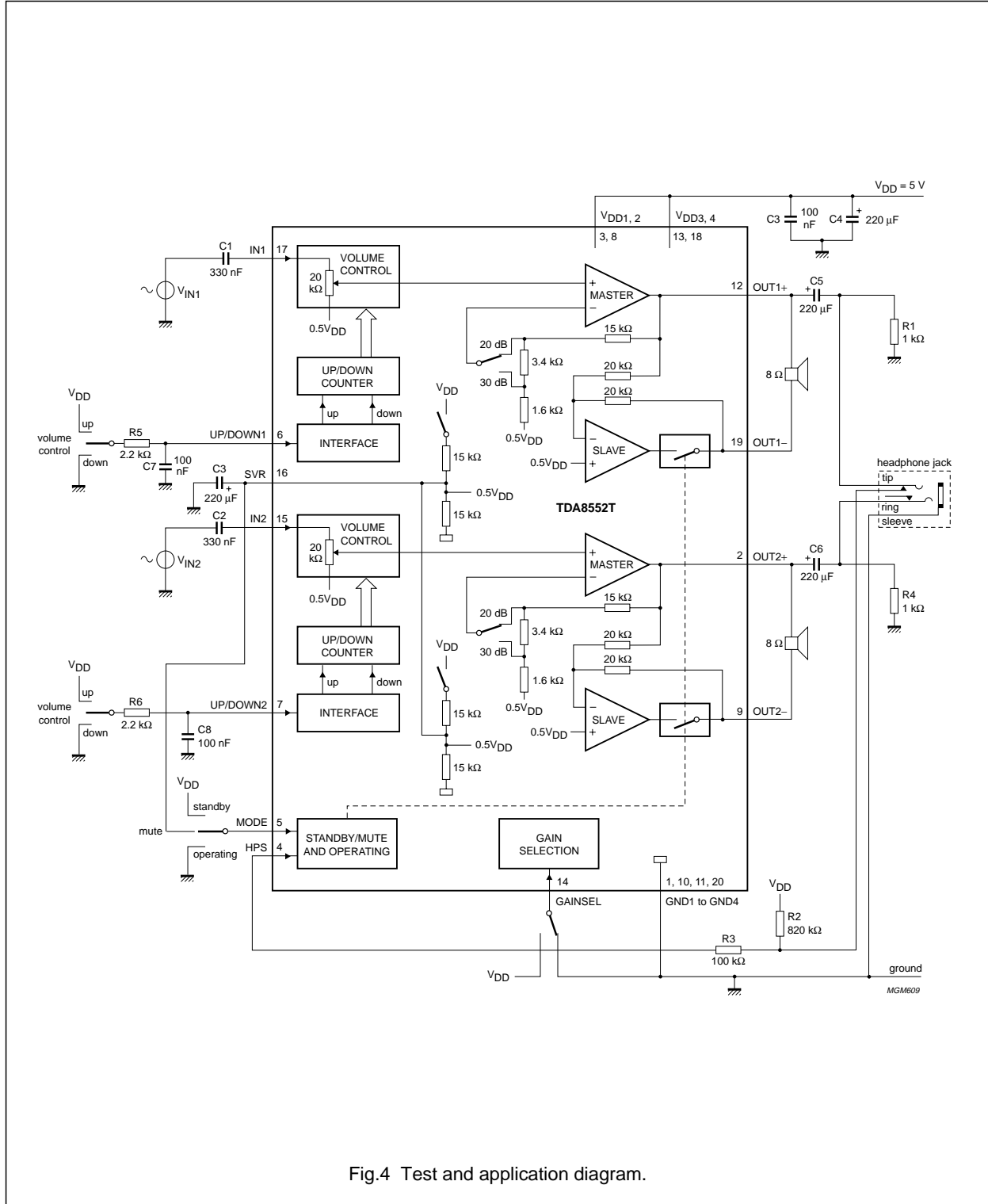

Fig.4 Test and application diagram.

## 2 × 1.4 W BTL audio amplifiers with digital volume control and headphone sensing

## TDA8552T; TDA8552TS

### Test conditions

$T_{amb} = 25^{\circ}\text{C}$  if not specially mentioned;  $V_{DD} = 5\text{ V}$ ;  
 $f = 1\text{ kHz}$ ,  $R_L = 8\ \Omega$ ,  $G_v = 20\text{ dB}$ , audio band-pass  
 22 Hz to 22 kHz. The thermal resistance (in standard print,  
 without extra copper) = 110 K/W for the SSOP20; the  
 maximum sine wave power dissipation is:

$$\frac{150 - 25}{110} = 1.14\text{ W}$$

For  $T_{amb} = 60^{\circ}\text{C}$  the maximum total power dissipation is:

$$\frac{150 - 60}{110} = 0.82\text{ W}$$

### Thermal design considerations

The 'measured' thermal resistance of the IC package is highly dependent on the configuration and size of the application board. All surface mount packages rely on the traces of the PCB to conduct heat away from the package. To improve the heat flow, a significant area on the PCB must be attached to the (ground) pins. Data may not be comparable between different semiconductor manufacturers because the application boards and test methods are not (yet) standardized. Also, the thermal performance of packages for a specific application may be different than presented here, because the configuration of the application boards (copper area) may be different. Philips Semiconductors uses FR-4 type application boards with 1 oz copper traces with solder coating Solder Resist Mask (SRM).

The SSOP20 package has improved thermal conductivity which reduces the thermal resistance. Using a practical PCB layout (see Fig.18) with wider copper tracks to the corner pins and just under the IC, the thermal resistance from junction to ambient can be reduced to approximately 80 K/W. For  $T_{amb} = 60^{\circ}\text{C}$  the maximum total power

dissipation for this PCB layout is:  $\frac{150 - 60}{80} = 1.12\text{ W}$

The thermal resistance for the SO20 is approximately 55 K/W if applied to a PCB with wider copper tracks to the corner pins and just under the body of the IC.

The maximum total power dissipation for this practical application is:

$$\frac{150 - 60}{55} = 1.63\text{ W}$$

### BTL application

The BTL application diagram is illustrated in Fig.4.

The quiescent current has been measured without any load impedance. The total harmonic distortion as a function of frequency was measured with a low-pass filter of 80 kHz. The value of capacitor C3 influences the behaviour of the SVRR at low frequencies, increasing the value of C3 increases the performance of the SVRR.

### Headphone application

$T_{amb} = 25^{\circ}\text{C}$  if not specially mentioned,  $V_{DD} = 5\text{ V}$ ,  
 $f = 1\text{ kHz}$ ,  $R_L = 32\ \Omega$ ,  $G_v = 14\text{ dB}$ , audio band-pass  
 22 Hz to 22 kHz.

For headphone application diagram see: Fig.4

If a headphone is plugged into the headphone jack, the HPS pin will switch-off the outputs of the SLAVE output stage, this results in a mute attenuation >80 dB for the loudspeakers. In this condition the quiescent current will be reduced.

### General remarks

Reduction of the value of capacitor C3 results in a decrease of the SVRR performance at low frequencies.

The capacitor value of C5 and C6 in combination with the load impedance of the headphone determines the low frequency behaviour.

To prevent against high output currents during inserting the headphone into the headphone jack, resistors of 5.1  $\Omega$  have to be connected in series with the SE output lines.

The UP/DOWN pin can be driven by a 3-state logic output stage (microprocessor) without extra external components. If the UP/DOWN pin is driven by push-buttons, then it is advised to have an RC-filter between the buttons and the UP/DOWN pin. Advised values for the RC-filter are 2.2 k $\Omega$  and 100 nF. Resistor R4 is not necessary for basic operation, but is advised to keep C6 charged to a voltage of 0.5V<sub>DD</sub>. This has the advantage that the plop noise when inserting the headphone plug is minimal. If the headphone sense function (HPS) is not used then the HPS-pin 4 should be hard-wired to ground. This pin should never be left unconnected.

Using double push buttons, the volume step for both channels can be controlled. When for the balance control only a single contact is used, the balance steps are 1.25 dB. If double contacts are used for the balance buttons and the dashed connection is made, then the balance steps are 2.5 dB.

## 2 × 1.4 W BTL audio amplifiers with digital volume control and headphone sensing

## TDA8552T; TDA8552TS

### Application without volume control

If pins 6, 7 and 8 are hardwired together the device operates with the volume control setting at maximum.

When the supply voltage is connected and the device is switched from standby to mute or operating for the first time then the gain is ramped up from -20 dB to +20 dB. This takes approximately 5 s.

This maximum gain setting is maintained until the supply voltage drops below the minimum value.

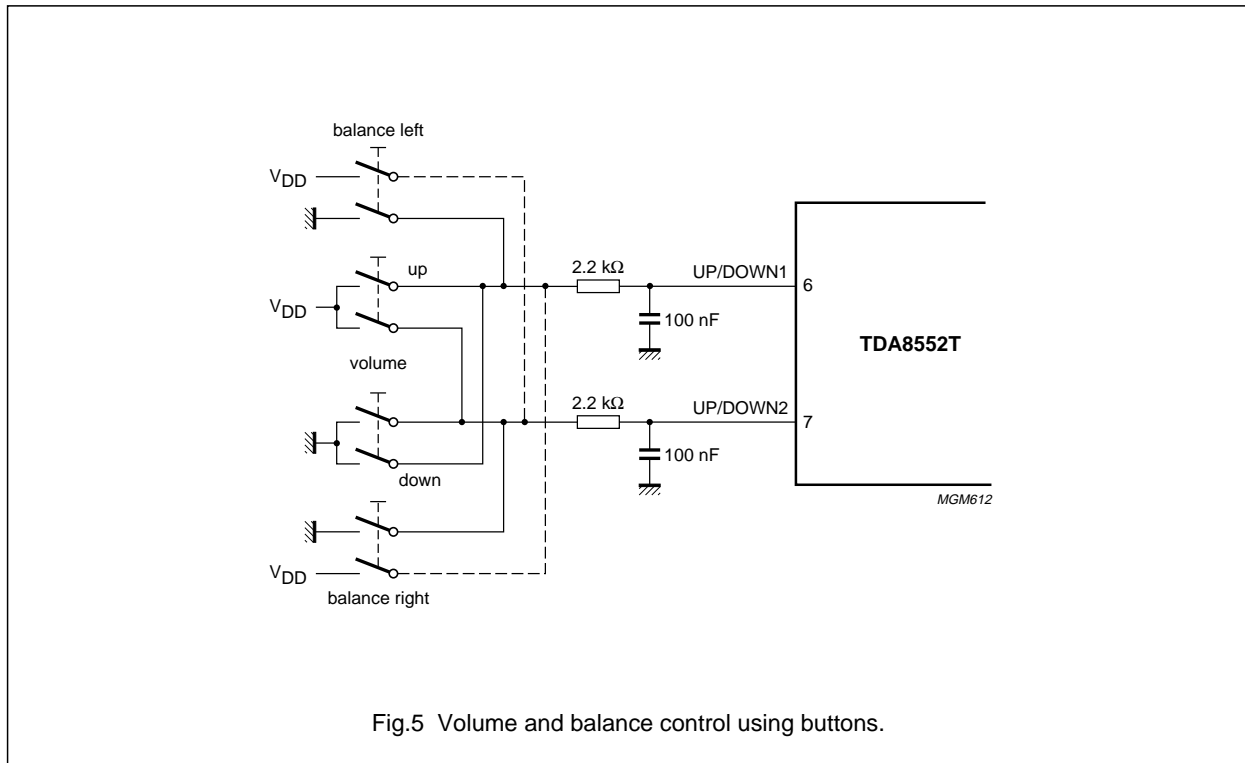
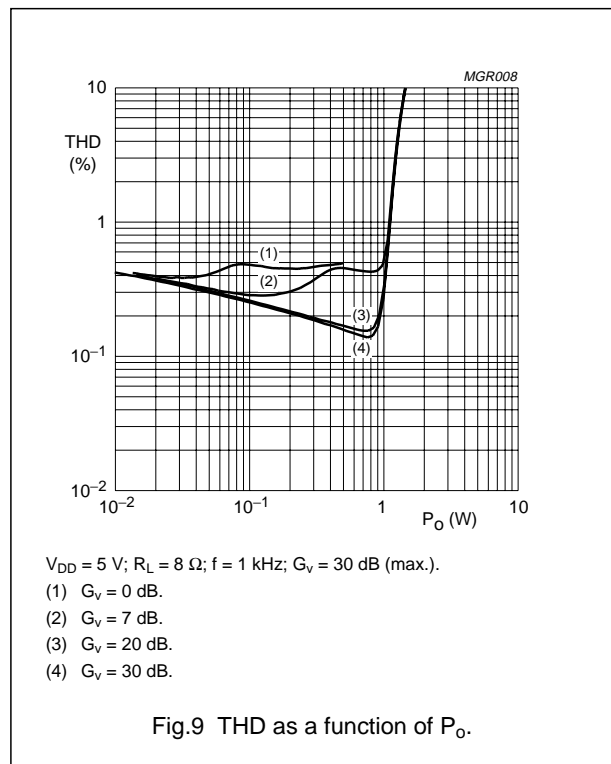
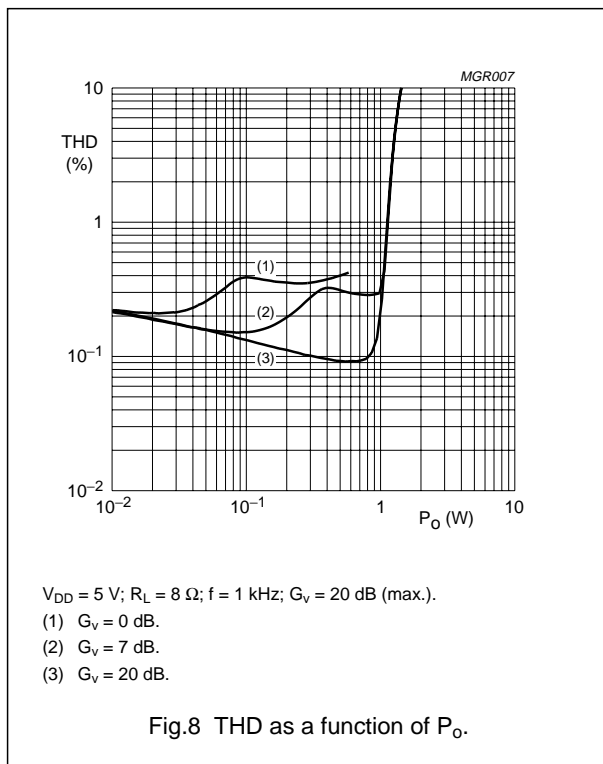
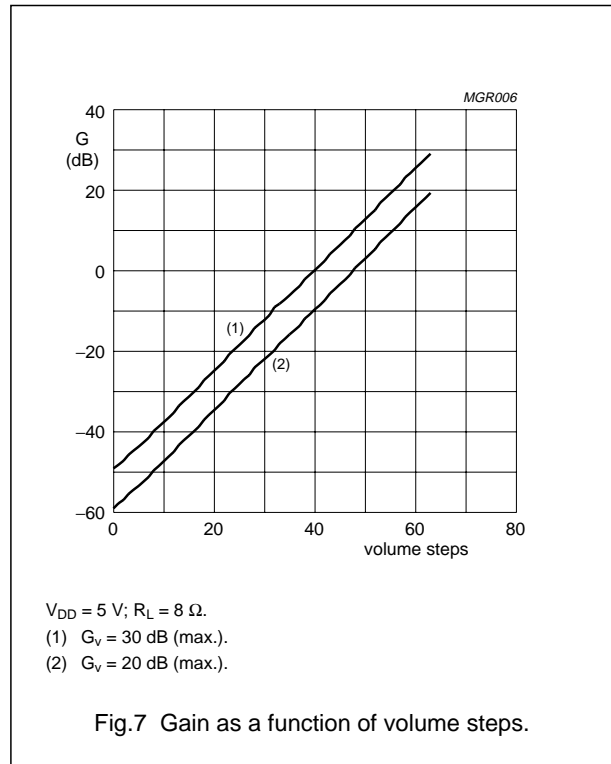
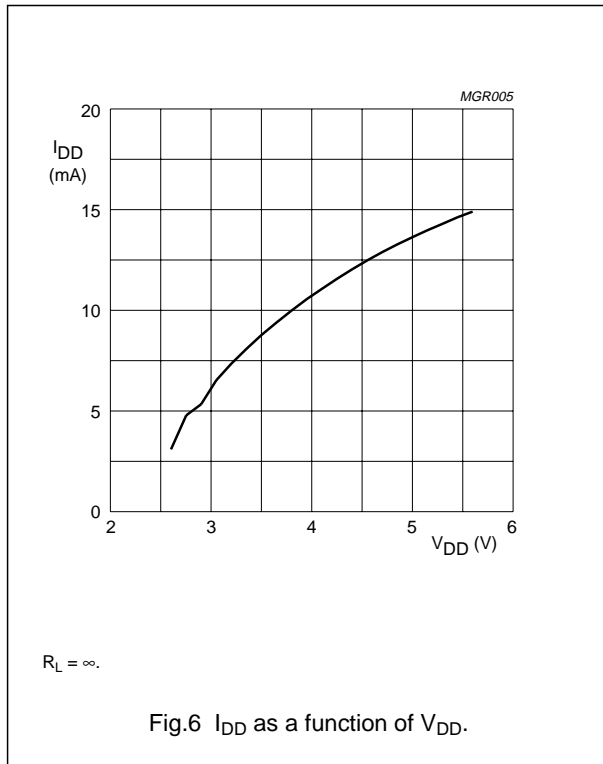

Fig.5 Volume and balance control using buttons.



2 × 1.4 W BTL audio amplifiers with digital volume control and headphone sensing

TDA8552T; TDA8552TS



2 × 1.4 W BTL audio amplifiers with digital volume control and headphone sensing

TDA8552T; TDA8552TS

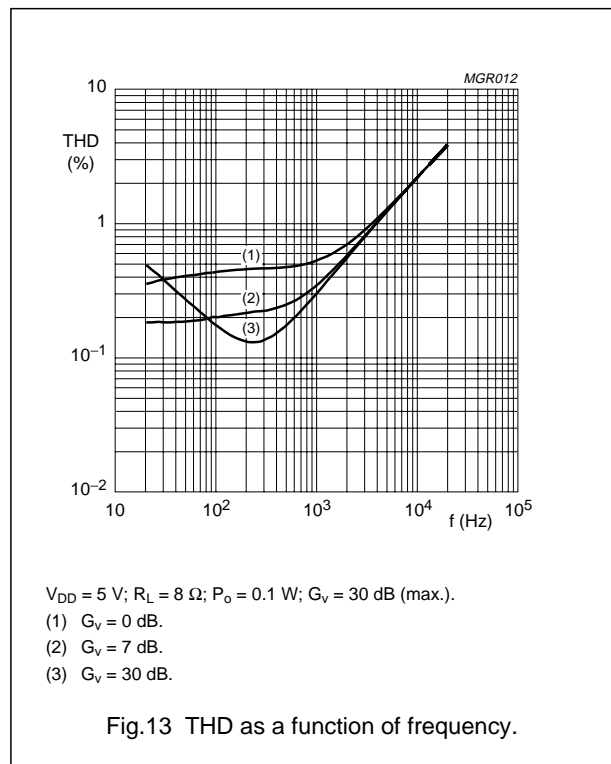
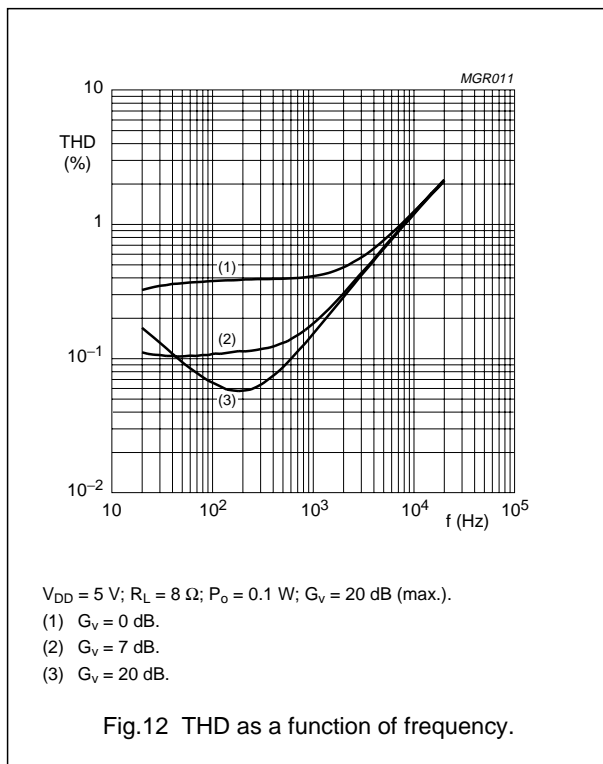
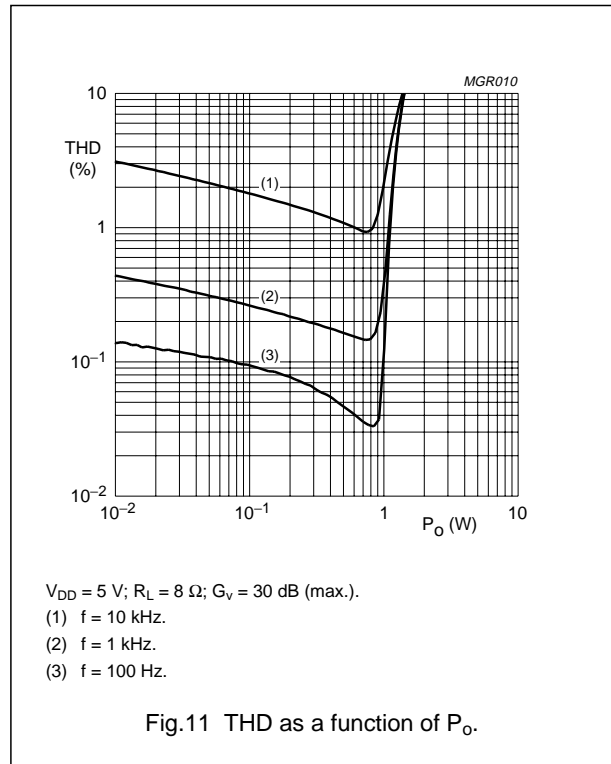
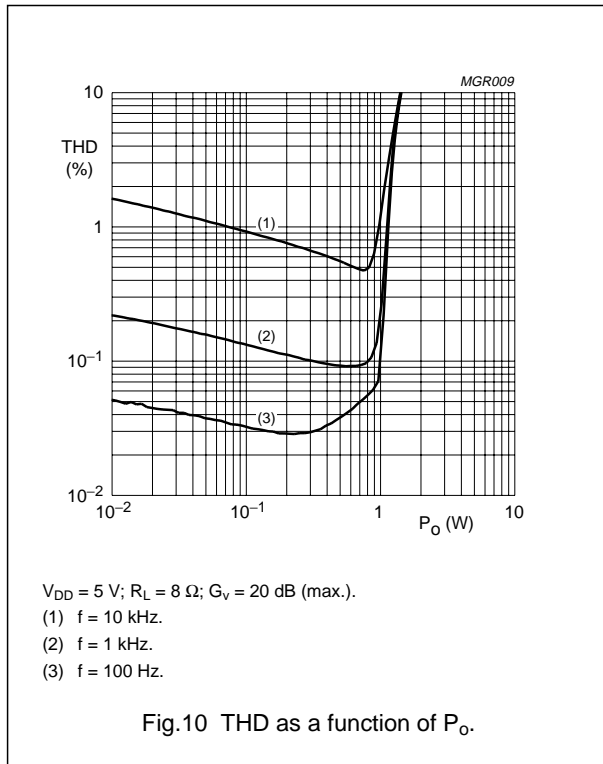

2 × 1.4 W BTL audio amplifiers with digital volume control and headphone sensing

TDA8552T; TDA8552TS

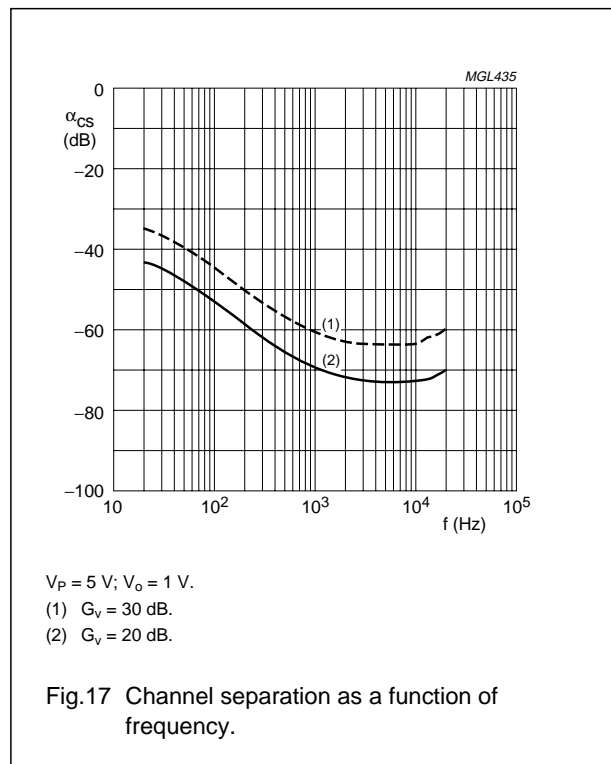
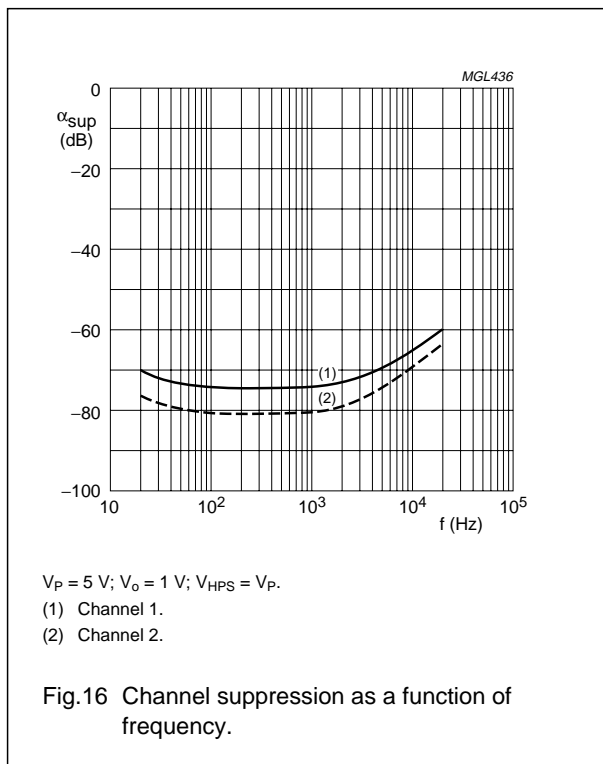
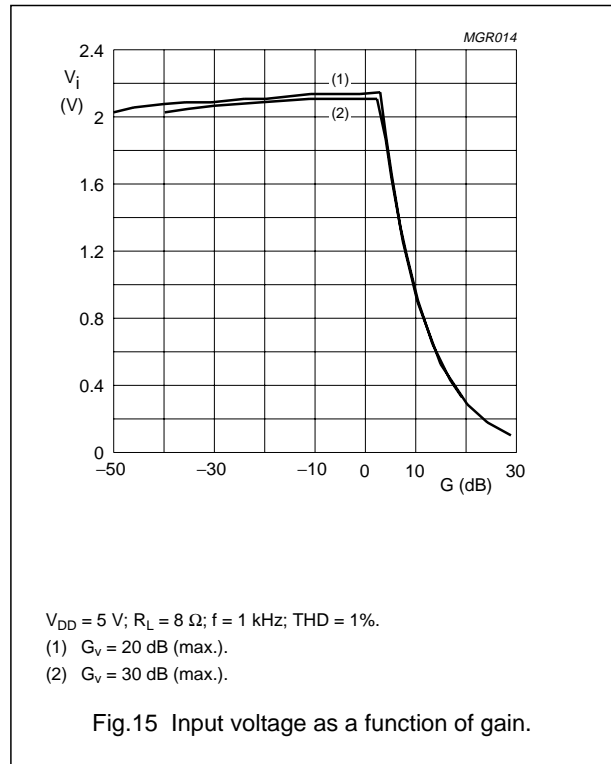
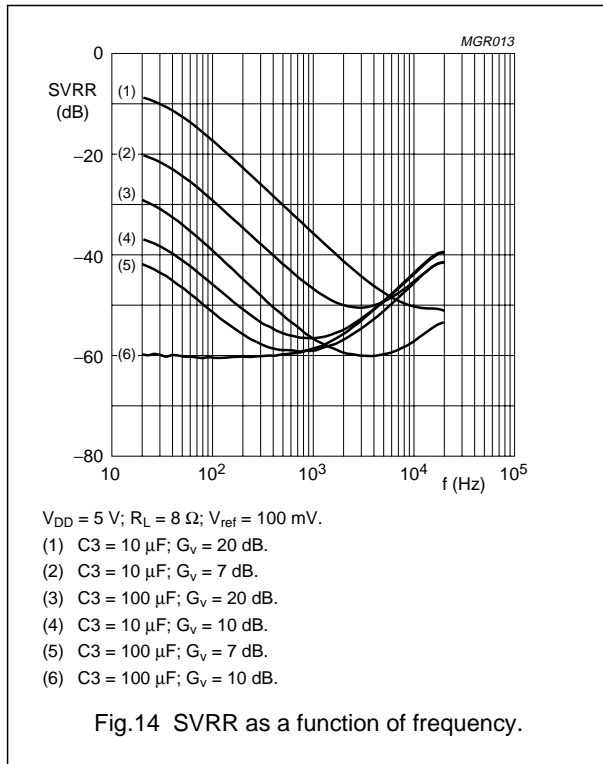

2 × 1.4 W BTL audio amplifiers with digital volume control and headphone sensing

TDA8552T; TDA8552TS

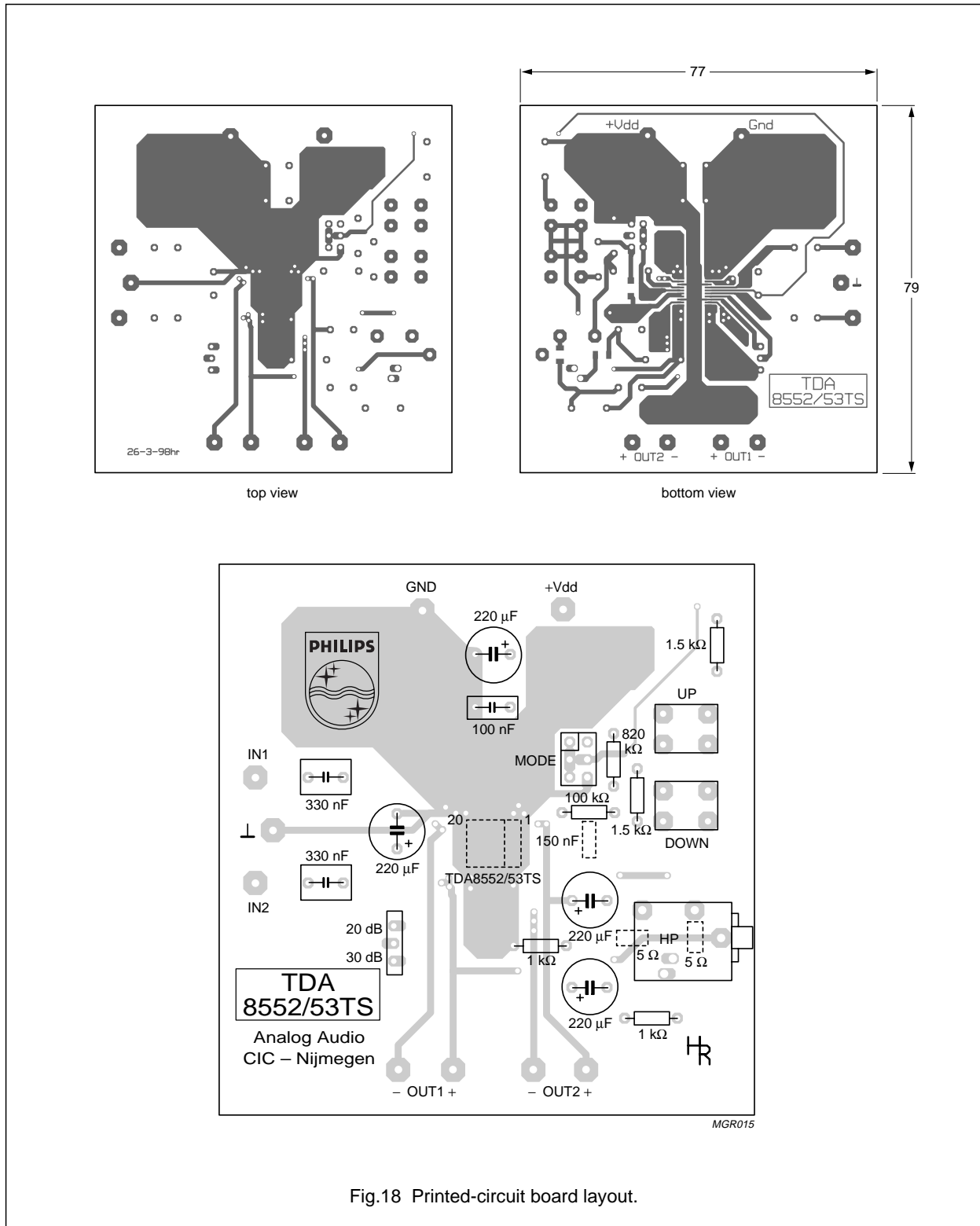

Fig.18 Printed-circuit board layout.

2 × 1.4 W BTL audio amplifiers with digital volume control and headphone sensing

TDA8552T; TDA8552TS

PACKAGE OUTLINES

SO20: plastic small outline package; 20 leads; body width 7.5 mm

SOT163-1

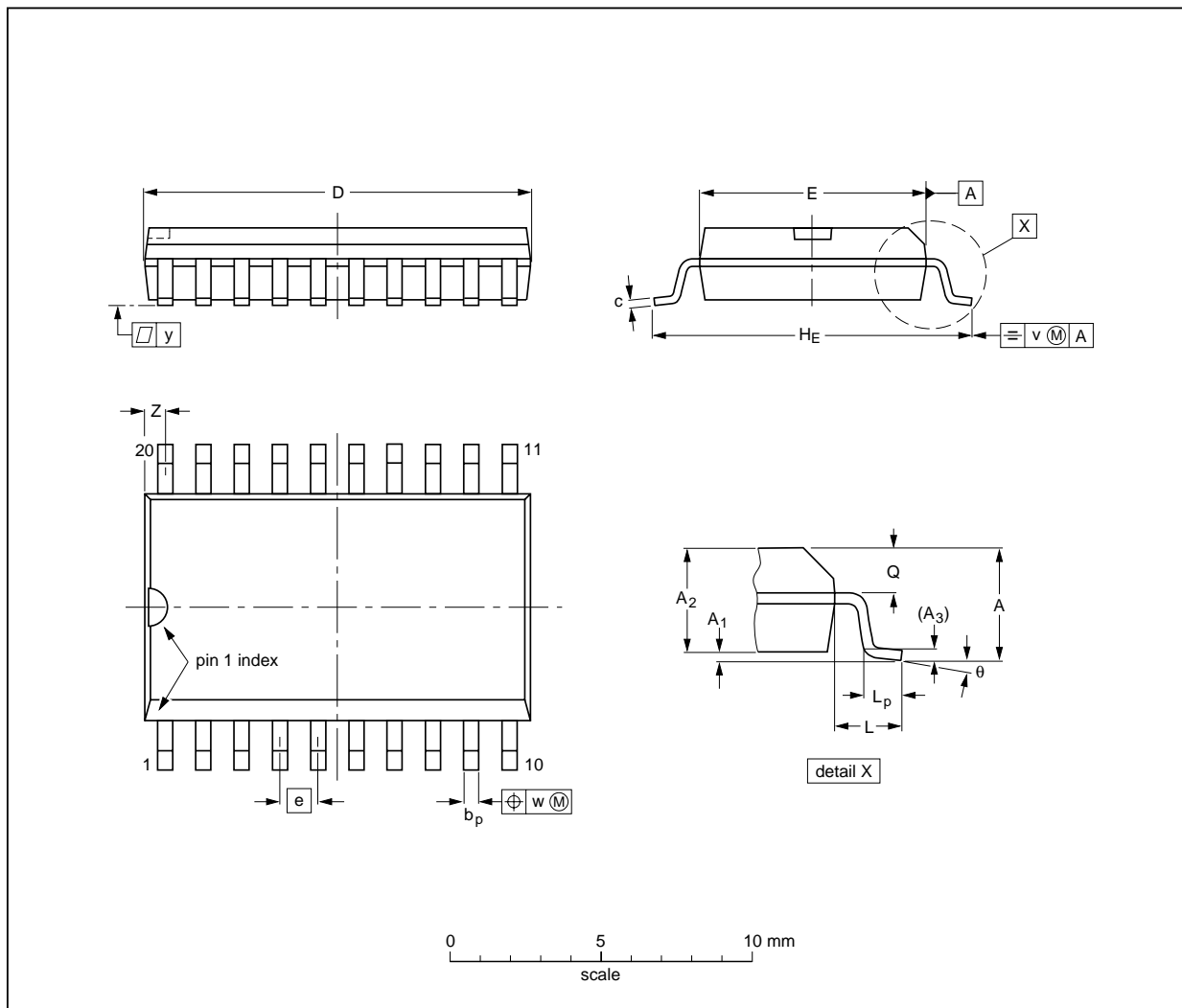

DIMENSIONS (inch dimensions are derived from the original mm dimensions)

UNIT	A max.	A <sub>1</sub>	A <sub>2</sub>	A <sub>3</sub>	b <sub>p</sub>	c	D <sup>(1)</sup>	E <sup>(1)</sup>	e	H <sub>E</sub>	L	L <sub>p</sub>	Q	v	w	y	Z <sup>(1)</sup>	θ
mm	2.65	0.30 0.10	2.45 2.25	0.25	0.49 0.36	0.32 0.23	13.0 12.6	7.6 7.4	1.27	10.65 10.00	1.4	1.1 0.4	1.1 1.0	0.25	0.25	0.1	0.9 0.4	8° 0°
inches	0.10	0.012 0.004	0.096 0.089	0.01	0.019 0.014	0.013 0.009	0.51 0.49	0.30 0.29	0.050	0.419 0.394	0.055	0.043 0.016	0.043 0.039	0.01	0.01	0.004	0.035 0.016	

Note

1. Plastic or metal protrusions of 0.15 mm maximum per side are not included.

OUTLINE VERSION	REFERENCES				EUROPEAN PROJECTION	ISSUE DATE
	IEC	JEDEC	EIAJ			
SOT163-1	075E04	MS-013AC				95-01-24 97-05-22

2 × 1.4 W BTL audio amplifiers with digital volume control and headphone sensing

TDA8552T; TDA8552TS

SSOP20: plastic shrink small outline package; 20 leads; body width 4.4 mm

SOT266-1

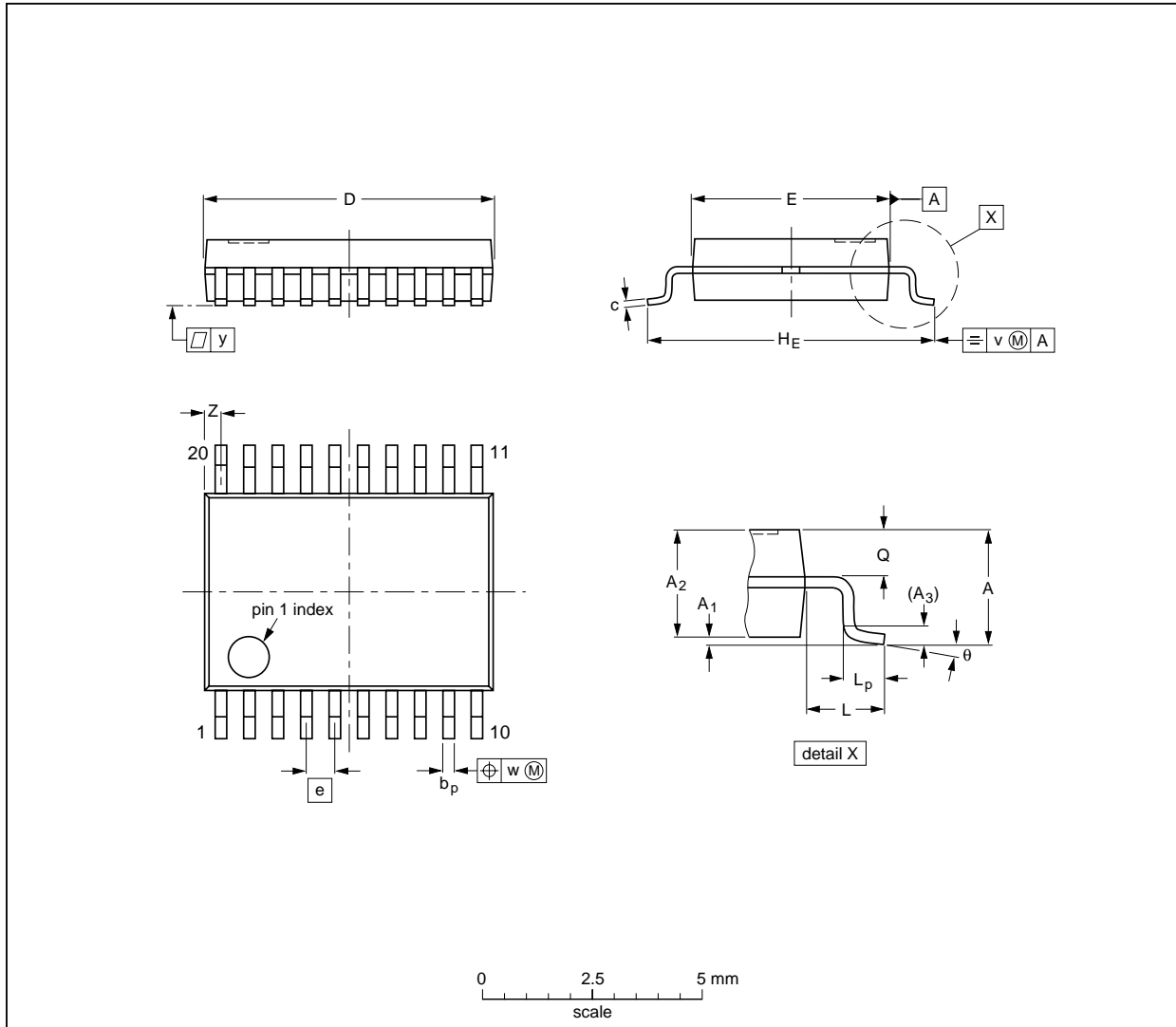

**DIMENSIONS (mm are the original dimensions)**

UNIT	A max.	A <sub>1</sub>	A <sub>2</sub>	A <sub>3</sub>	b <sub>p</sub>	c	D <sup>(1)</sup>	E <sup>(1)</sup>	e	H <sub>E</sub>	L	L <sub>p</sub>	Q	v	w	y	Z <sup>(1)</sup>	θ
mm	1.5	0.15 0	1.4 1.2	0.25	0.32 0.20	0.20 0.13	6.6 6.4	4.5 4.3	0.65	6.6 6.2	1.0	0.75 0.45	0.65 0.45	0.2	0.13	0.1	0.48 0.18	10° 0°

**Note**

1. Plastic or metal protrusions of 0.20 mm maximum per side are not included.

OUTLINE VERSION	REFERENCES				EUROPEAN PROJECTION	ISSUE DATE
	IEC	JEDEC	EIAJ			
SOT266-1						90-04-05 95-02-25

## 2 × 1.4 W BTL audio amplifiers with digital volume control and headphone sensing

## TDA8552T; TDA8552TS

### SOLDERING

#### Introduction

There is no soldering method that is ideal for all IC packages. Wave soldering is often preferred when through-hole and surface mounted components are mixed on one printed-circuit board. However, wave soldering is not always suitable for surface mounted ICs, or for printed-circuits with high population densities. In these situations reflow soldering is often used.

This text gives a very brief insight to a complex technology. A more in-depth account of soldering ICs can be found in our "IC Package Databook" (order code 9398 652 90011).

#### Reflow soldering

Reflow soldering techniques are suitable for all SO and SSOP packages.

Reflow soldering requires solder paste (a suspension of fine solder particles, flux and binding agent) to be applied to the printed-circuit board by screen printing, stencilling or pressure-syringe dispensing before package placement.

Several techniques exist for reflowing; for example, thermal conduction by heated belt. Dwell times vary between 50 and 300 seconds depending on heating method. Typical reflow temperatures range from 215 to 250 °C.

Preheating is necessary to dry the paste and evaporate the binding agent. Preheating duration: 45 minutes at 45 °C.

#### Wave soldering

##### SO

Wave soldering techniques can be used for all SO packages if the following conditions are observed:

- A double-wave (a turbulent wave with high upward pressure followed by a smooth laminar wave) soldering technique should be used.
- The longitudinal axis of the package footprint must be parallel to the solder flow.
- The package footprint must incorporate solder thieves at the downstream end.

##### SSOP

Wave soldering is **not** recommended for SSOP packages. This is because of the likelihood of solder bridging due to closely-spaced leads and the possibility of incomplete solder penetration in multi-lead devices.

**If wave soldering cannot be avoided, the following conditions must be observed:**

- **A double-wave (a turbulent wave with high upward pressure followed by a smooth laminar wave) soldering technique should be used.**
- **The longitudinal axis of the package footprint must be parallel to the solder flow and must incorporate solder thieves at the downstream end.**

**Even with these conditions, only consider wave soldering SSOP packages that have a body width of 4.4 mm, that is SSOP16 (SOT369-1) or SSOP20 (SOT266-1).**

##### METHOD (SO AND SSOP)

During placement and before soldering, the package must be fixed with a droplet of adhesive. The adhesive can be applied by screen printing, pin transfer or syringe dispensing. The package can be soldered after the adhesive is cured.

Maximum permissible solder temperature is 260 °C, and maximum duration of package immersion in solder is 10 seconds, if cooled to less than 150 °C within 6 seconds. Typical dwell time is 4 seconds at 250 °C.

A mildly-activated flux will eliminate the need for removal of corrosive residues in most applications.

#### Repairing soldered joints

Fix the component by first soldering two diagonally-opposite end leads. Use only a low voltage soldering iron (less than 24 V) applied to the flat part of the lead. Contact time must be limited to 10 seconds at up to 300 °C. When using a dedicated tool, all other leads can be soldered in one operation within 2 to 5 seconds between 270 and 320 °C.

---

**2 × 1.4 W BTL audio amplifiers with digital  
volume control and headphone sensing**

---

**TDA8552T; TDA8552TS**

---

**DEFINITIONS**

<b>Data sheet status</b>	
Objective specification	This data sheet contains target or goal specifications for product development.
Preliminary specification	This data sheet contains preliminary data; supplementary data may be published later.
Product specification	This data sheet contains final product specifications.
<b>Limiting values</b>	
Limiting values given are in accordance with the Absolute Maximum Rating System (IEC 134). Stress above one or more of the limiting values may cause permanent damage to the device. These are stress ratings only and operation of the device at these or at any other conditions above those given in the Characteristics sections of the specification is not implied. Exposure to limiting values for extended periods may affect device reliability.	
<b>Application information</b>	
Where application information is given, it is advisory and does not form part of the specification.	

**LIFE SUPPORT APPLICATIONS**

These products are not designed for use in life support appliances, devices, or systems where malfunction of these products can reasonably be expected to result in personal injury. Philips customers using or selling these products for use in such applications do so at their own risk and agree to fully indemnify Philips for any damages resulting from such improper use or sale.



---

2 × 1.4 W BTL audio amplifiers with digital  
volume control and headphone sensing

---

TDA8552T; TDA8552TS

**NOTES**

---

2 × 1.4 W BTL audio amplifiers with digital  
volume control and headphone sensing

---

TDA8552T; TDA8552TS

**NOTES**

---

2 × 1.4 W BTL audio amplifiers with digital  
volume control and headphone sensing

---

TDA8552T; TDA8552TS

**NOTES**

# Philips Semiconductors – a worldwide company

**Argentina:** see South America

**Australia:** 34 Waterloo Road, NORTH RYDE, NSW 2113,  
Tel. +61 2 9805 4455, Fax. +61 2 9805 4466

**Austria:** Computerstr. 6, A-1101 WIEN, P.O. Box 213, Tel. +43 160 1010,  
Fax. +43 160 101 1210

**Belarus:** Hotel Minsk Business Center, Bld. 3, r. 1211, Volodarski Str. 6,  
220050 MINSK, Tel. +375 172 200 733, Fax. +375 172 200 773

**Belgium:** see The Netherlands

**Brazil:** see South America

**Bulgaria:** Philips Bulgaria Ltd., Energoproject, 15th floor,  
51 James Bouchier Blvd., 1407 SOFIA,  
Tel. +359 2 689 211, Fax. +359 2 689 102

**Canada:** PHILIPS SEMICONDUCTORS/COMPONENTS,  
Tel. +1 800 234 7381

**China/Hong Kong:** 501 Hong Kong Industrial Technology Centre,  
72 Tat Chee Avenue, Kowloon Tong, HONG KONG,  
Tel. +852 2319 7888, Fax. +852 2319 7700

**Colombia:** see South America

**Czech Republic:** see Austria

**Denmark:** Prags Boulevard 80, PB 1919, DK-2300 COPENHAGEN S,  
Tel. +45 32 88 2636, Fax. +45 31 57 0044

**Finland:** Sinikalliontie 3, FIN-02630 ESPOO,  
Tel. +358 9 615800, Fax. +358 9 61580920

**France:** 51 Rue Carnot, BP317, 92156 SURESNES Cedex,  
Tel. +33 1 40 99 6161, Fax. +33 1 40 99 6427

**Germany:** Hammerbrookstraße 69, D-20097 HAMBURG,  
Tel. +49 40 23 53 60, Fax. +49 40 23 536 300

**Greece:** No. 15, 25th March Street, GR 17778 TAVROS/ATHENS,  
Tel. +30 1 4894 339/239, Fax. +30 1 4814 240

**Hungary:** see Austria

**India:** Philips INDIA Ltd, Band Box Building, 2nd floor,  
254-D, Dr. Annie Besant Road, Worli, MUMBAI 400 025,  
Tel. +91 22 493 8541, Fax. +91 22 493 0966

**Indonesia:** PT Philips Development Corporation, Semiconductors Division,  
Gedung Philips, Jl. Buncit Raya Kav.99-100, JAKARTA 12510,  
Tel. +62 21 794 0040 ext. 2501, Fax. +62 21 794 0080

**Ireland:** Newstead, Clonskeagh, DUBLIN 14,  
Tel. +353 1 7640 000, Fax. +353 1 7640 200

**Israel:** RAPAC Electronics, 7 Kehilat Saloniki St, PO Box 18053,  
TEL AVIV 61180, Tel. +972 3 645 0444, Fax. +972 3 649 1007

**Italy:** PHILIPS SEMICONDUCTORS, Piazza IV Novembre 3,  
20124 MILANO, Tel. +39 2 6752 2531, Fax. +39 2 6752 2557

**Japan:** Philips Bldg 13-37, Kohnan 2-chome, Minato-ku,  
TOKYO 108-8507, Tel. +81 3 3740 5130, Fax. +81 3 3740 5077

**Korea:** Philips House, 260-199 Itaewon-dong, Yongsan-ku, SEOUL,  
Tel. +82 2 709 1412, Fax. +82 2 709 1415

**Malaysia:** No. 76 Jalan Universiti, 46200 PETALING JAYA, SELANGOR,  
Tel. +60 3 750 5214, Fax. +60 3 757 4880

**Mexico:** 5900 Gateway East, Suite 200, EL PASO, TEXAS 79905,  
Tel. +9-5 800 234 7381

**Middle East:** see Italy

**Netherlands:** Postbus 90050, 5600 PB EINDHOVEN, Bldg. VB,  
Tel. +31 40 27 82785, Fax. +31 40 27 88399

**New Zealand:** 2 Wagener Place, C.P.O. Box 1041, AUCKLAND,  
Tel. +64 9 849 4160, Fax. +64 9 849 7811

**Norway:** Box 1, Manglerud 0612, OSLO,  
Tel. +47 22 74 8000, Fax. +47 22 74 8341

**Pakistan:** see Singapore

**Philippines:** Philips Semiconductors Philippines Inc.,  
106 Valero St. Salcedo Village, P.O. Box 2108 MCC, MAKATI,  
Metro MANILA, Tel. +63 2 816 6380, Fax. +63 2 817 3474

**Poland:** Ul. Lukiska 10, PL 04-123 WARSZAWA,  
Tel. +48 22 612 2831, Fax. +48 22 612 2327

**Portugal:** see Spain

**Romania:** see Italy

**Russia:** Philips Russia, Ul. Usatcheva 35A, 119048 MOSCOW,  
Tel. +7 095 755 6918, Fax. +7 095 755 6919

**Singapore:** Lorong 1, Toa Payoh, SINGAPORE 319762,  
Tel. +65 350 2538, Fax. +65 251 6500

**Slovakia:** see Austria

**Slovenia:** see Italy

**South Africa:** S.A. PHILIPS Pty Ltd., 195-215 Main Road Martindale,  
2092 JOHANNESBURG, P.O. Box 7430 Johannesburg 2000,  
Tel. +27 11 470 5911, Fax. +27 11 470 5494

**South America:** Al. Vicente Pinzon, 173, 6th floor,  
04547-130 SÃO PAULO, SP, Brazil,  
Tel. +55 11 821 2333, Fax. +55 11 821 2382

**Spain:** Balmes 22, 08007 BARCELONA,  
Tel. +34 93 301 6312, Fax. +34 93 301 4107

**Sweden:** Kottbygatan 7, Akalla, S-16485 STOCKHOLM,  
Tel. +46 8 5985 2000, Fax. +46 8 5985 2745

**Switzerland:** Allmendstrasse 140, CH-8027 ZÜRICH,  
Tel. +41 1 488 2741 Fax. +41 1 488 3263

**Taiwan:** Philips Semiconductors, 6F, No. 96, Chien Kuo N. Rd., Sec. 1,  
TAIPEI, Taiwan Tel. +886 2 2134 2865, Fax. +886 2 2134 2874

**Thailand:** PHILIPS ELECTRONICS (THAILAND) Ltd.,  
209/2 Sanpavuth-Bangna Road Prakanong, BANGKOK 10260,  
Tel. +66 2 745 4090, Fax. +66 2 398 0793

**Turkey:** Talatpasa Cad. No. 5, 80640 GÜLTEPE/ISTANBUL,  
Tel. +90 212 279 2770, Fax. +90 212 282 6707

**Ukraine:** PHILIPS UKRAINE, 4 Patrice Lumumba str., Building B, Floor 7,  
252042 KIEV, Tel. +380 44 264 2776, Fax. +380 44 268 0461

**United Kingdom:** Philips Semiconductors Ltd., 276 Bath Road, Hayes,  
MIDDLESEX UB3 5BX, Tel. +44 181 730 5000, Fax. +44 181 754 8421

**United States:** 811 East Arques Avenue, SUNNYVALE, CA 94088-3409,  
Tel. +1 800 234 7381

**Uruguay:** see South America

**Vietnam:** see Singapore

**Yugoslavia:** PHILIPS, Trg N. Pasica 5/v, 11000 BEOGRAD,  
Tel. +381 11 625 344, Fax. +381 11 635 777

**For all other countries apply to:** Philips Semiconductors,  
International Marketing & Sales Communications, Building BE-p, P.O. Box 218,  
5600 MD EINDHOVEN, The Netherlands, Fax. +31 40 27 24825

**Internet:** <http://www.semiconductors.philips.com>

© Philips Electronics N.V. 1998

SCA60

All rights are reserved. Reproduction in whole or in part is prohibited without the prior written consent of the copyright owner.

The information presented in this document does not form part of any quotation or contract, is believed to be accurate and reliable and may be changed without notice. No liability will be accepted by the publisher for any consequence of its use. Publication thereof does not convey nor imply any license under patent- or other industrial or intellectual property rights.

Printed in The Netherlands

545102/1200/02/pp28

Date of release: 1998 Jun 02

Document order number: 9397 750 03733

*Let's make things better.*

**Philips**  
**Semiconductors**



**PHILIPS**