

## Rail-to-Rail Input/Output, 10 MHz Op Amps

### Features

- Rail-to-Rail Input/Output
- Wide Bandwidth: 10 MHz (typ.)
- Low Noise: 8.7 nV/ $\sqrt{\text{Hz}}$ , at 10 kHz (typ.)
- Low Offset Voltage:
  - Industrial Temperature:  $\pm 500 \mu\text{V}$  (max.)
  - Extended Temperature:  $\pm 250 \mu\text{V}$  (max.)
- Mid-Supply  $V_{\text{REF}}$ : MCP6021 and MCP6023
- Low Supply Current: 1 mA (typ.)
- Total Harmonic Distortion: 0.00053% (typ., G = 1)
- Unity Gain Stable
- Power Supply Range: 2.5V to 5.5V
- Temperature Range:
  - Industrial:  $-40^{\circ}\text{C}$  to  $+85^{\circ}\text{C}$
  - Extended:  $-40^{\circ}\text{C}$  to  $+125^{\circ}\text{C}$

### Description

The MCP6021, MCP6022, MCP6023 and MCP6024 from Microchip Technology Inc. are rail-to-rail input and output op amps with high performance. Key specifications include: wide bandwidth (10 MHz), low noise (8.7 nV/ $\sqrt{\text{Hz}}$ ), low input offset voltage and low distortion (0.00053% THD+N). These features make these op amps well suited for applications requiring high performance and bandwidth. The MCP6023 also offers a chip select pin ( $\overline{\text{CS}}$ ) that gives power savings when the part is not in use.

The single MCP6021, single MCP6023 and dual MCP6022 are available in standard 8-lead PDIP, SOIC and TSSOP. The quad MCP6024 is offered in 14-lead PDIP, SOIC and TSSOP packages.

The MCP6021/2/3/4 family is available in the Industrial and Extended temperature ranges. It has a power supply range of 2.5V to 5.5V.

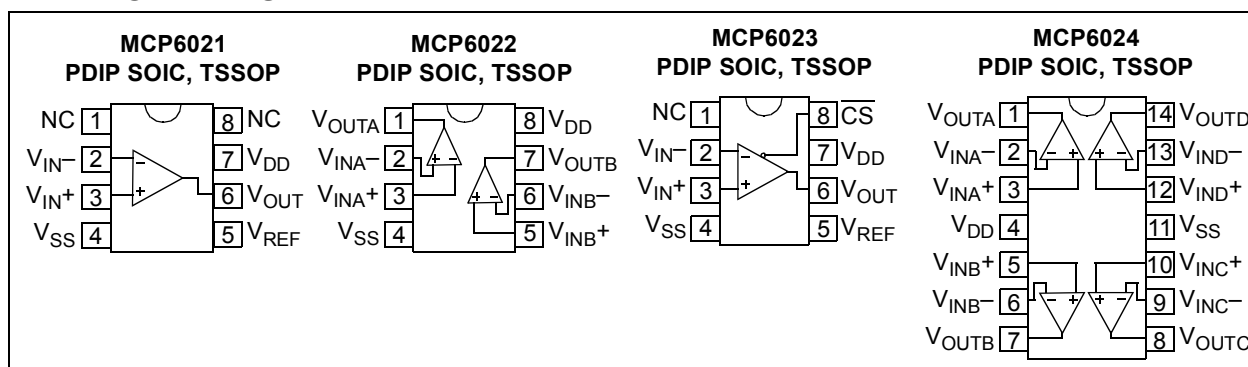
### Typical Applications

- Automotive
- Driving A/D Converters
- Multi-Pole Active Filters
- Barcode Scanners
- Audio Processing
- Communications
- DAC Buffer
- Test Equipment
- Medical Instrumentation

### Available Tools

- SPICE Macro Model (at [www.microchip.com](http://www.microchip.com))
- FilterLab<sup>®</sup> software (at [www.microchip.com](http://www.microchip.com))

### PACKAGE TYPES



# MCP6021/2/3/4

## 1.0 ELECTRICAL CHARACTERISTICS

### Absolute Maximum Ratings †

$V_{DD} - V_{SS}$ .....	7.0V
All Inputs and Outputs .....	$V_{SS} - 0.3V$ to $V_{DD} + 0.3V$
Difference Input Voltage .....	$ V_{DD} - V_{SS} $
Output Short Circuit Current .....	continuous
Current at Input Pins .....	$\pm 2$ mA
Current at Output and Supply Pins .....	$\pm 30$ mA
Storage Temperature .....	$-65^{\circ}\text{C}$ to $+150^{\circ}\text{C}$
Junction Temperature .....	$+150^{\circ}\text{C}$
ESD Protection on all pins (HBM/MM) .....	$\geq 2$ kV / 200V

† **Notice:** Stresses above those listed under "Maximum Ratings" may cause permanent damage to the device. This is a stress rating only and functional operation of the device at those or any other conditions above those indicated in the operational listings of this specification is not implied. Exposure to maximum rating conditions for extended periods may affect device reliability.

### DC CHARACTERISTICS

<b>Electrical Specifications:</b> Unless otherwise indicated, $T_A = +25^{\circ}\text{C}$ , $V_{DD} = +2.5V$ to $+5.5V$ , $V_{SS} = \text{GND}$ , $V_{CM} = V_{DD}/2$ , $V_{OUT} \approx V_{DD}/2$ and $R_L = 10$ k $\Omega$ to $V_{DD}/2$ .						
Parameters	Sym	Min	Typ	Max	Units	Conditions
<b>Input Offset</b>						
Input Offset Voltage:						
Industrial Temperature Parts	$V_{OS}$	-500	—	+500	$\mu\text{V}$	$V_{CM} = 0V$
Extended Temperature Parts	$V_{OS}$	-250	—	+250	$\mu\text{V}$	$V_{CM} = 0V$ , $V_{DD} = 5.0V$
Extended Temperature Parts	$V_{OS}$	-2.5	—	+2.5	mV	$V_{CM} = 0V$ , $V_{DD} = 5.0V$ $T_A = -40^{\circ}\text{C}$ to $+125^{\circ}\text{C}$
Input Offset Voltage Temperature Drift	$\Delta V_{OS}/\Delta T_A$	—	$\pm 3.5$	—	$\mu\text{V}/^{\circ}\text{C}$	$T_A = -40^{\circ}\text{C}$ to $+125^{\circ}\text{C}$
Power Supply Rejection Ratio	PSRR	74	90	—	dB	$V_{CM} = 0V$
<b>Input Current and Impedance</b>						
Input Bias Current	$I_B$	—	1	—	pA	
Industrial Temperature Parts	$I_B$	—	30	150	pA	$T_A = +85^{\circ}\text{C}$
Extended Temperature Parts	$I_B$	—	640	5,000	pA	$T_A = +125^{\circ}\text{C}$
Input Offset Current	$I_{OS}$	—	$\pm 1$	—	pA	
Common-Mode Input Impedance	$Z_{CM}$	—	$10^{13}  6$	—	$\Omega  \text{pF}$	
Differential Input Impedance	$Z_{DIFF}$	—	$10^{13}  3$	—	$\Omega  \text{pF}$	
<b>Common-Mode</b>						
Common-Mode Input Range	$V_{CMR}$	$V_{SS}-0.3$	—	$V_{DD}+0.3$	V	
Common-Mode Rejection Ratio	CMRR	74	90	—	dB	$V_{DD} = 5V$ , $V_{CM} = -0.3V$ to $5.3V$
	CMRR	70	85	—	dB	$V_{DD} = 5V$ , $V_{CM} = 3.0V$ to $5.3V$
	CMRR	74	90	—	dB	$V_{DD} = 5V$ , $V_{CM} = -0.3V$ to $3.0V$
<b>Voltage Reference (MCP6021 and MCP6023 only)</b>						
$V_{REF}$ Accuracy ( $V_{REF} - V_{DD}/2$ )	$\Delta V_{REF}$	-50	—	+50	mV	
$V_{REF}$ Temperature Drift	$\Delta V_{REF}/\Delta T_A$	—	$\pm 100$	—	$\mu\text{V}/^{\circ}\text{C}$	$T_A = -40^{\circ}\text{C}$ to $+125^{\circ}\text{C}$
Open Loop Gain						
DC Open Loop Gain (Large Signal)	$A_{OL}$	90	110	—	dB	$V_{CM} = 0V$ , $V_{OUT} = V_{SS}+0.3V$ to $V_{DD}-0.3V$

### Pin Function Table

Name	Function
$V_{IN+}$ , $V_{INA+}$ , $V_{INB+}$ , $V_{INC+}$ , $V_{IND+}$	Non-inverting Inputs
$V_{IN-}$ , $V_{INA-}$ , $V_{INB-}$ , $V_{INC-}$ , $V_{IND-}$	Inverting Inputs
$V_{DD}$	Positive Power Supply
$V_{SS}$	Negative Power Supply
$\overline{\text{CS}}$	Chip Select
$V_{REF}$	Reference Voltage
$V_{OUT}$ , $V_{OUTA}$ , $V_{OUTB}$ , $V_{OUTC}$ , $V_{OUTD}$	Outputs
NC	No Internal Connection

## DC CHARACTERISTICS (CONTINUED)

**Electrical Specifications:** Unless otherwise indicated,  $T_A = +25^\circ\text{C}$ ,  $V_{DD} = +2.5\text{V}$  to  $+5.5\text{V}$ ,  $V_{SS} = \text{GND}$ ,  $V_{CM} = V_{DD}/2$ ,  $V_{OUT} \approx V_{DD}/2$  and  $R_L = 10\text{ k}\Omega$  to  $V_{DD}/2$ .

Parameters	Sym	Min	Typ	Max	Units	Conditions
<b>Output</b>						
Maximum Output Voltage Swing	$V_{OL}, V_{OH}$	$V_{SS}+15$	—	$V_{DD}-20$	mV	0.5V output overdrive
Output Short Circuit Current	$I_{SC}$	—	$\pm 30$	—	mA	
<b>Power Supply</b>						
Supply Voltage	$V_S$	2.5	—	5.5	V	
Quiescent Current per Amplifier	$I_Q$	0.5	1.0	1.35	mA	$I_O = 0$

## AC CHARACTERISTICS

**Electrical Specifications:** Unless otherwise indicated,  $T_A = 25^\circ\text{C}$ ,  $V_{DD} = +2.5\text{V}$  to  $+5.5\text{V}$ ,  $V_{SS} = \text{GND}$ ,  $V_{CM} = V_{DD}/2$ ,  $V_{OUT} \approx V_{DD}/2$ ,  $R_L = 10\text{ k}\Omega$  to  $V_{DD}/2$  and  $C_L = 60\text{ pF}$ .

Parameters	Sym	Min	Typ	Max	Units	Conditions
<b>AC Response</b>						
Gain Bandwidth Product	GBWP	—	10	—	MHz	
Phase Margin at Unity-Gain	PM	—	65	—	°	$G = 1$
Settling Time, 0.2%	$t_{SETTLE}$	—	250	—	ns	$G = 1, V_{OUT} = 100\text{ mV}_{p-p}$
Slew Rate	SR	—	7.0	—	V/ $\mu\text{s}$	
<b>Total Harmonic Distortion Plus Noise</b>						
$f = 1\text{ kHz}, G = 1$	THD+N	—	0.00053	—	%	$V_{OUT} = 0.25\text{V} + 3.25\text{V}, \text{BW} = 22\text{ kHz}$
$f = 1\text{ kHz}, G = 1, R_L = 600\Omega @ 1\text{ kHz}$	THD+N	—	0.00064	—	%	$V_{OUT} = 0.25\text{V} + 3.25\text{V}, \text{BW} = 22\text{ kHz}$
$f = 1\text{ kHz}, G = +1\text{ V/V}$	THD+N	—	0.0014	—	%	$V_{OUT} = 4V_{P-P}, V_{DD} = 5.0\text{V}, \text{BW} = 22\text{ kHz}$
$f = 1\text{ kHz}, G = +10\text{ V/V}$	THD+N	—	0.0009	—	%	$V_{OUT} = 4V_{P-P}, V_{DD} = 5.0\text{V}, \text{BW} = 22\text{ kHz}$
$f = 1\text{ kHz}, G = +100\text{ V/V}$	THD+N	—	0.005	—	%	$V_{OUT} = 4V_{P-P}, V_{DD} = 5.0\text{V}, \text{BW} = 22\text{ kHz}$
<b>Noise</b>						
Input Voltage Noise	$E_{ni}$	—	2.9	—	$\mu\text{V}_{p-p}$	$f = 0.1\text{ Hz}$ to $10\text{ Hz}$
Input Voltage Noise Density	$e_{ni}$	—	8.7	—	nV/ $\sqrt{\text{Hz}}$	$f = 10\text{ kHz}$
Input Current Noise Density	$i_{ni}$	—	3	—	fA/ $\sqrt{\text{Hz}}$	$f = 1\text{ kHz}$

## MCP6023 CHIP SELECT ( $\overline{\text{CS}}$ ) CHARACTERISTICS

**Electrical Specifications:** Unless otherwise indicated,  $T_A = 25^\circ\text{C}$ ,  $V_{DD} = +2.5\text{V}$  to  $+5.5\text{V}$ ,  $V_{SS} = \text{GND}$ ,  $V_{CM} = V_{DD}/2$ ,  $V_{OUT} \approx V_{DD}/2$ ,  $R_L = 10\text{ k}\Omega$  to  $V_{DD}/2$  and  $C_L = 60\text{ pF}$ .

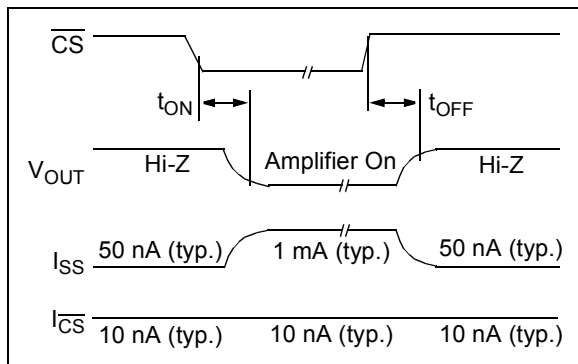
Parameters	Sym	Min	Typ	Max	Units	Conditions
<b>DC Characteristics</b>						
$\overline{\text{CS}}$ Logic Threshold, Low	$V_{IL}$	0	—	$0.2V_{DD}$	V	
$\overline{\text{CS}}$ Input Current, Low	$I_{CSL}$	-1.0	0.01	—	$\mu\text{A}$	$\overline{\text{CS}} = V_{SS}$
$\overline{\text{CS}}$ Logic Threshold, High	$V_{IH}$	$0.8V_{DD}$	—	$V_{DD}$	V	
$\overline{\text{CS}}$ Input Current, High	$I_{CSH}$	—	0.01	2.0	$\mu\text{A}$	$\overline{\text{CS}} = V_{DD}$
$\overline{\text{CS}}$ Input High, GND Current	$I_{SS}$	—	0.05	2.0	$\mu\text{A}$	$\overline{\text{CS}} = V_{DD}$
Amplifier Output Leakage	—	—	0.01	—	$\mu\text{A}$	$\overline{\text{CS}} = V_{DD}$
<b>Timing</b>						
$\overline{\text{CS}}$ Low to Amplifier Output Turn-on Time	$t_{ON}$	—	2	10	$\mu\text{s}$	$G = 1, V_{IN} = V_{SS}, \overline{\text{CS}} = 0.2V_{DD}$ to $V_{OUT} = 0.45V_{DD}$ time
$\overline{\text{CS}}$ High to Amplifier Output High-Z Turn-off Time	$t_{OFF}$	—	0.01	—	$\mu\text{s}$	$G = 1, V_{IN} = V_{SS}, \overline{\text{CS}} = 0.8V_{DD}$ to $V_{OUT} = 0.05V_{DD}$ time
Hysteresis	$V_{HYST}$	—	0.6	—	V	Internal Switch

# MCP6021/2/3/4

## TEMPERATURE CHARACTERISTICS

Electrical Specifications: Unless otherwise indicated, $V_{DD} = +2.5V$ to $+5.5V$ and $V_{SS} = GND$ .						
Parameters	Symbol	Min	Typ	Max	Units	Conditions
<b>Temperature Ranges</b>						
Industrial Temperature Range	$T_A$	-40	—	+85	°C	
Extended Temperature Range	$T_A$	-40	—	+125	°C	
Operating Temperature Range	$T_A$	-40	—	+125	°C	<b>Note 1</b>
Storage Temperature Range	$T_A$	-65	—	+150	°C	
<b>Thermal Package Resistances</b>						
Thermal Resistance, 8L-PDIP	$\theta_{JA}$	—	85	—	°C/W	
Thermal Resistance, 8L-SOIC	$\theta_{JA}$	—	163	—	°C/W	
Thermal Resistance, 8L-TSSOP	$\theta_{JA}$	—	124	—	°C/W	
Thermal Resistance, 14L-PDIP	$\theta_{JA}$	—	70	—	°C/W	
Thermal Resistance, 14L-SOIC	$\theta_{JA}$	—	120	—	°C/W	
Thermal Resistance, 14L-TSSOP	$\theta_{JA}$	—	100	—	°C/W	

**Note 1:** The industrial temperature devices operate over this extended temperature range, but with reduced performance. In any case, the internal junction temperature ( $T_J$ ) must not exceed the absolute maximum specification of 150°C.

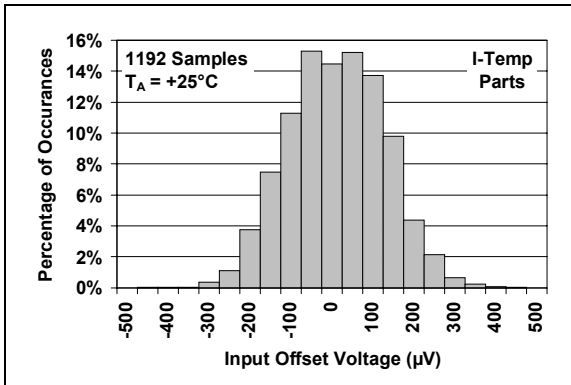


**FIGURE 1-1:** Timing diagram for the  $\overline{CS}$  pin on the MCP6023.

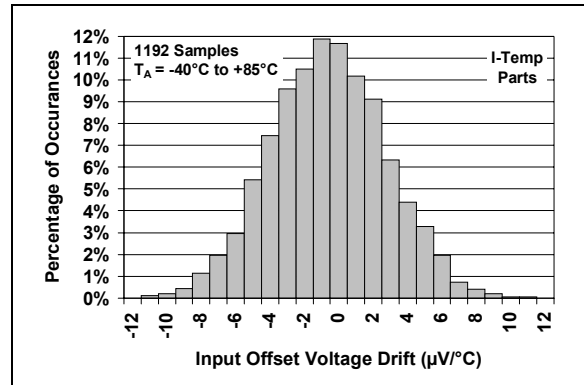
## 2.0 TYPICAL PERFORMANCE CURVES

**Note:** The graphs and tables provided following this note are a statistical summary based on a limited number of samples and are provided for informational purposes only. The performance characteristics listed herein are not tested or guaranteed. In some graphs or tables, the data presented may be outside the specified operating range (e.g., outside specified power supply range) and therefore outside the warranted range.

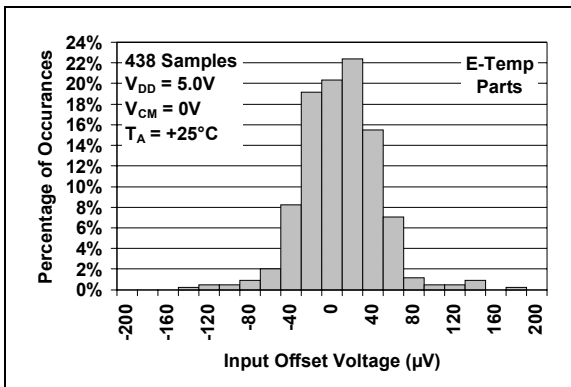
**Note:** Unless otherwise indicated,  $T_A = +25^\circ\text{C}$ ,  $V_{DD} = +2.5\text{V}$  to  $+5.5\text{V}$ ,  $V_{SS} = \text{GND}$ ,  $V_{CM} = V_{DD}/2$ ,  $R_L = 10\text{ k}\Omega$  to  $V_{DD}/2$ ,  $V_{OUT} \approx V_{DD}/2$  and  $C_L = 60\text{ pF}$ .



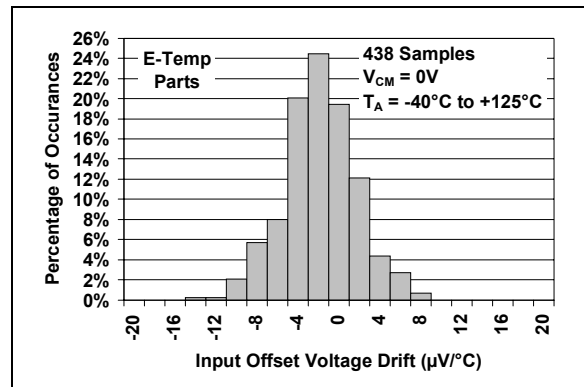
**FIGURE 2-1:** Input Offset Voltage, (Industrial Temperature Parts).



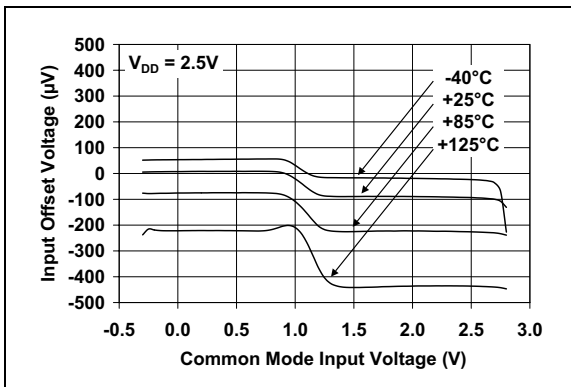
**FIGURE 2-4:** Input Offset Voltage Drift, (Industrial Temperature Parts).



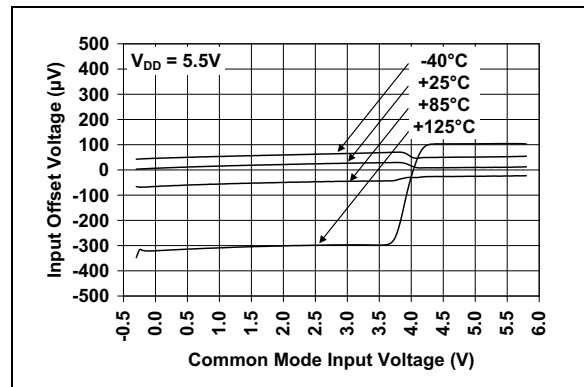
**FIGURE 2-2:** Input Offset Voltage, (Extended Temperature Parts).



**FIGURE 2-5:** Input Offset Voltage Drift, (Extended Temperature Parts).



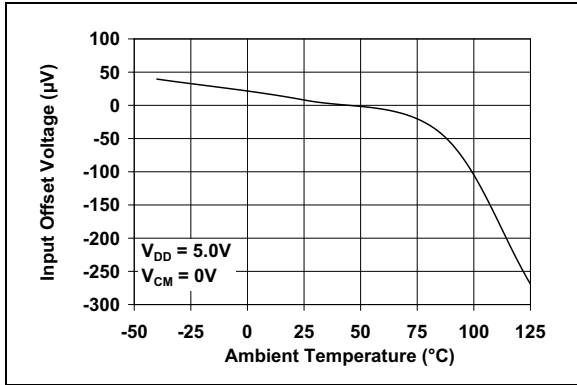
**FIGURE 2-3:** Input Offset Voltage vs. Common Mode Input Voltage with  $V_{DD} = 2.5\text{V}$ .



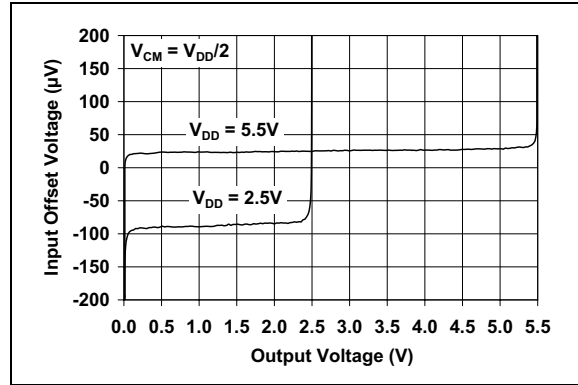
**FIGURE 2-6:** Input Offset Voltage vs. Common Mode Input Voltage with  $V_{DD} = 5.5\text{V}$ .

# MCP6021/2/3/4

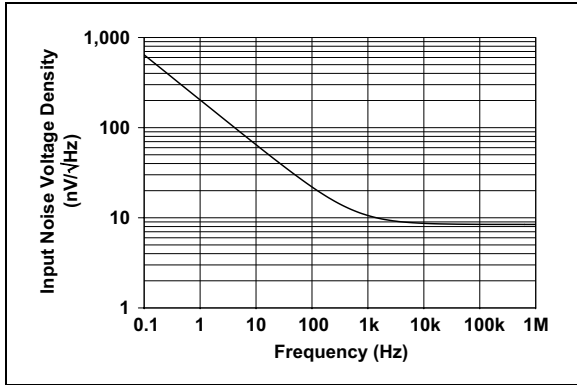
**Note:** Unless otherwise indicated,  $T_A = +25^\circ\text{C}$ ,  $V_{DD} = +2.5\text{V}$  to  $+5.5\text{V}$ ,  $V_{SS} = \text{GND}$ ,  $V_{CM} = V_{DD}/2$ ,  $R_L = 10\text{ k}\Omega$  to  $V_{DD}/2$ ,  $V_{OUT} \approx V_{DD}/2$  and  $C_L = 60\text{ pF}$ .



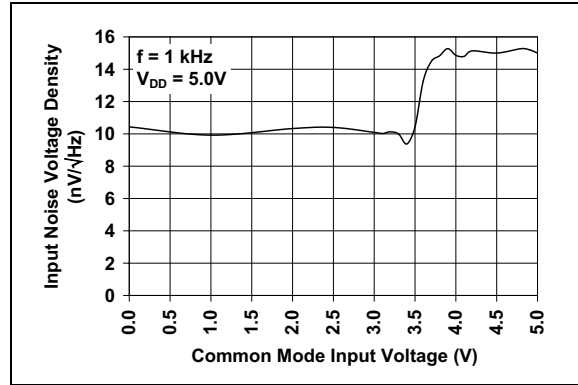
**FIGURE 2-7:** *Input Offset Voltage vs. Temperature.*



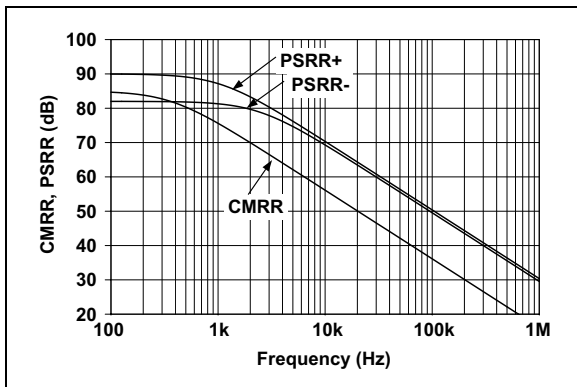
**FIGURE 2-10:** *Input Offset Voltage vs. Output Voltage.*



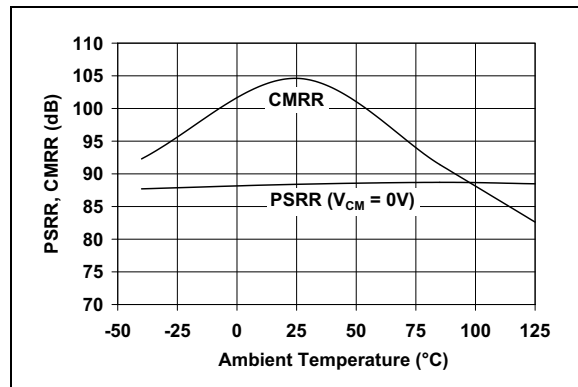
**FIGURE 2-8:** *Input Noise Voltage Density vs. Frequency.*



**FIGURE 2-11:** *Input Noise Voltage Density vs. Common Mode Input Voltage.*

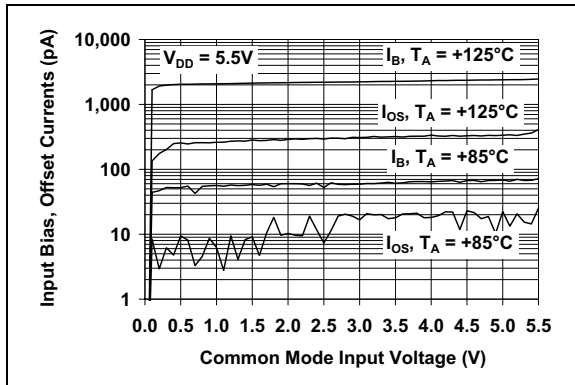


**FIGURE 2-9:** *Common Mode, Power Supply Rejection Ratios vs. Frequency.*

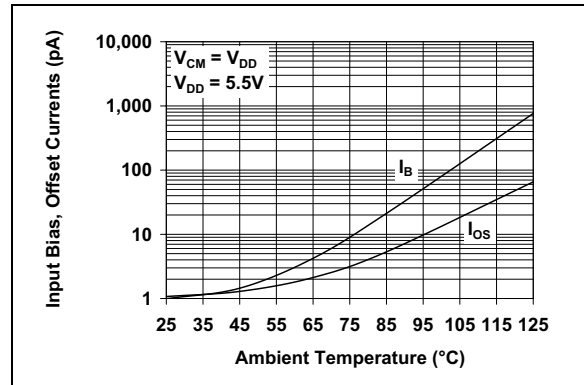


**FIGURE 2-12:** *Common Mode, Power Supply Rejection Ratios vs. Temperature.*

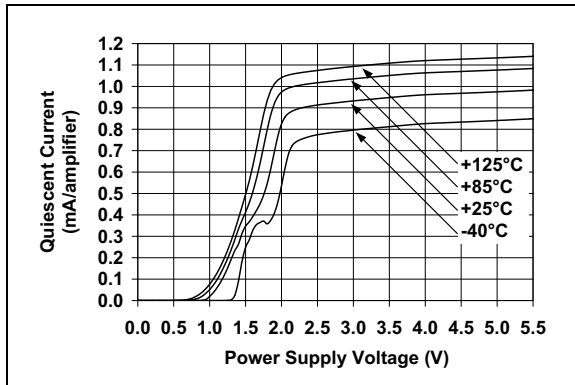
**Note:** Unless otherwise indicated,  $T_A = +25^\circ\text{C}$ ,  $V_{DD} = +2.5\text{V}$  to  $+5.5\text{V}$ ,  $V_{SS} = \text{GND}$ ,  $V_{CM} = V_{DD}/2$ ,  $R_L = 10\text{ k}\Omega$  to  $V_{DD}/2$ ,  $V_{OUT} \approx V_{DD}/2$  and  $C_L = 60\text{ pF}$ .



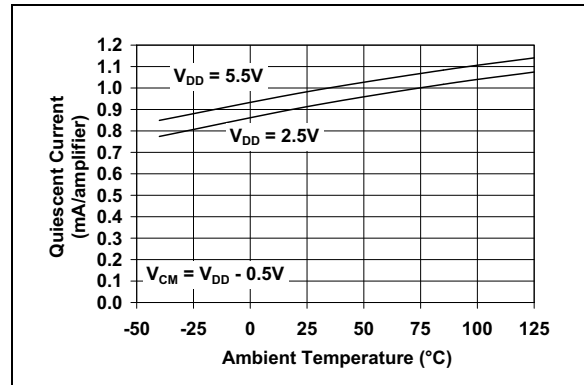
**FIGURE 2-13:** Input Bias, Offset Currents vs. Common Mode Input Voltage.



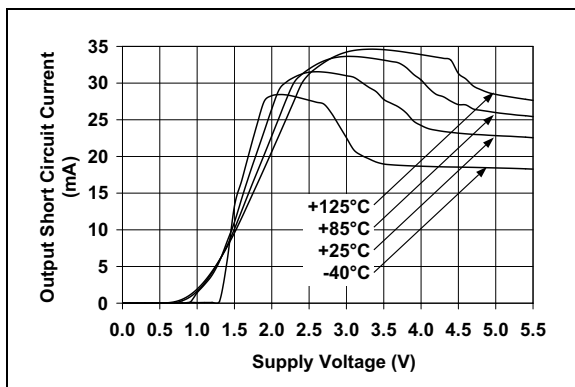
**FIGURE 2-16:** Input Bias, Offset Currents vs. Temperature.



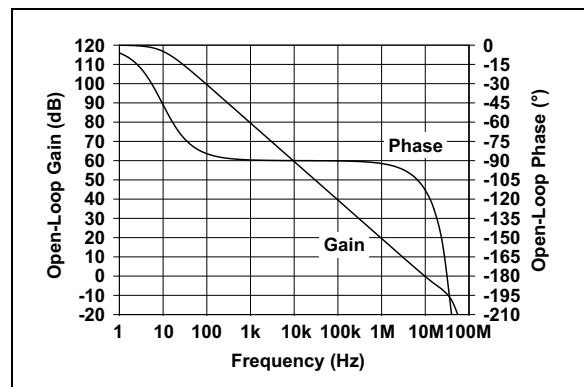
**FIGURE 2-14:** Quiescent Current vs. Supply Voltage.



**FIGURE 2-17:** Quiescent Current vs. Temperature.



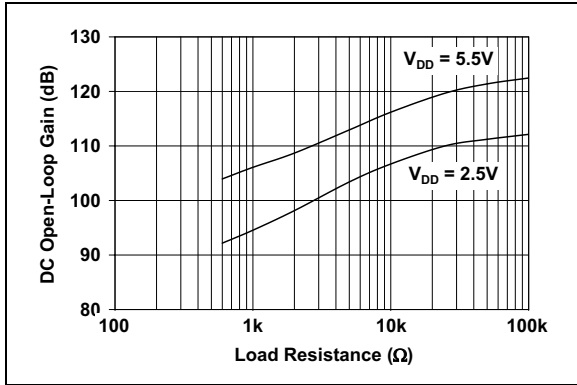
**FIGURE 2-15:** Output Short-Circuit Current vs. Supply Voltage.



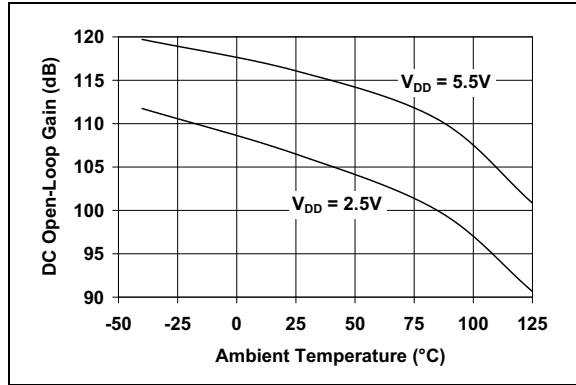
**FIGURE 2-18:** Open-Loop Gain, Phase vs. Frequency.

# MCP6021/2/3/4

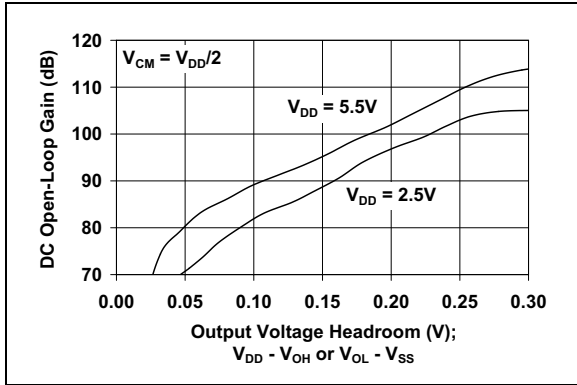
**Note:** Unless otherwise indicated,  $T_A = +25^\circ\text{C}$ ,  $V_{DD} = +2.5\text{V}$  to  $+5.5\text{V}$ ,  $V_{SS} = \text{GND}$ ,  $V_{CM} = V_{DD}/2$ ,  $R_L = 10\text{ k}\Omega$  to  $V_{DD}/2$ ,  $V_{OUT} \approx V_{DD}/2$  and  $C_L = 60\text{ pF}$ .



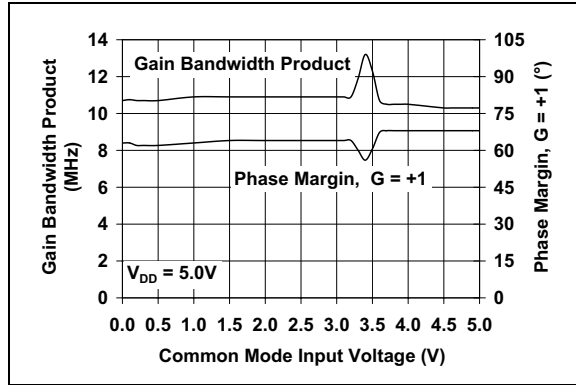
**FIGURE 2-19:** DC Open-Loop Gain vs. Load Resistance.



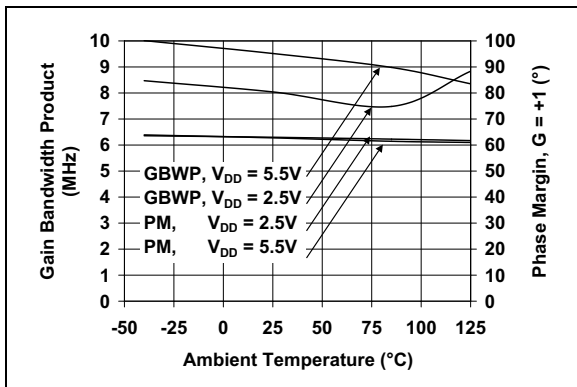
**FIGURE 2-22:** DC Open-Loop Gain vs. Temperature.



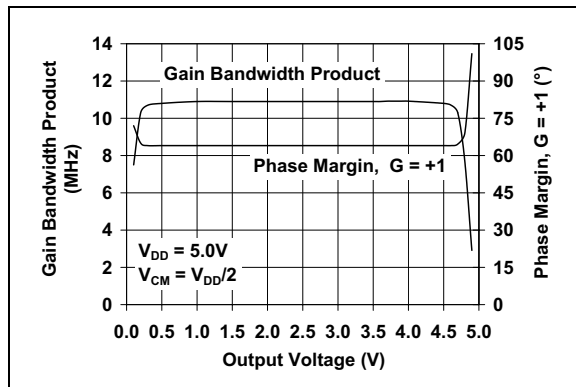
**FIGURE 2-20:** Small Signal DC Open-Loop Gain vs. Output Voltage Headroom.



**FIGURE 2-23:** Gain Bandwidth Product, Phase Margin vs. Common Mode Input Voltage.



**FIGURE 2-21:** Gain Bandwidth Product, Phase Margin vs. Temperature.

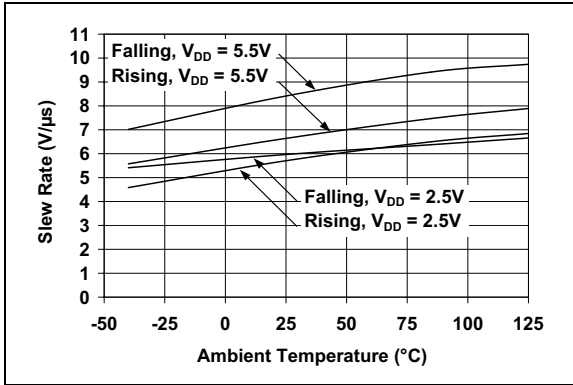


**FIGURE 2-24:** Gain Bandwidth Product, Phase Margin vs. Output Voltage.

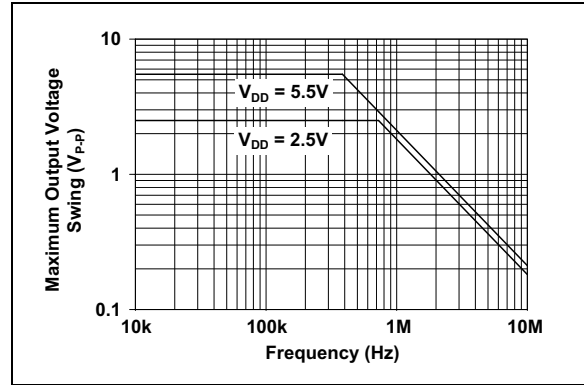


# MCP6021/2/3/4

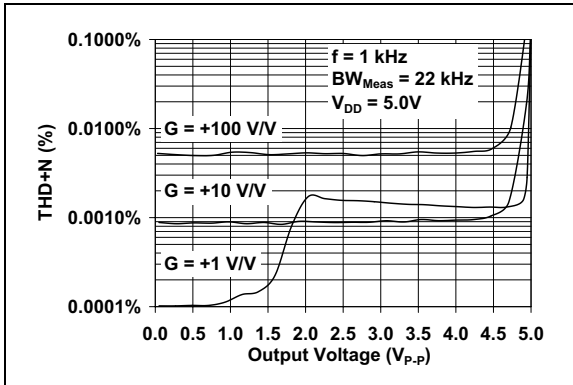
**Note:** Unless otherwise indicated,  $T_A = +25^\circ\text{C}$ ,  $V_{DD} = +2.5\text{V}$  to  $+5.5\text{V}$ ,  $V_{SS} = \text{GND}$ ,  $V_{CM} = V_{DD}/2$ ,  $R_L = 10\text{ k}\Omega$  to  $V_{DD}/2$ ,  $V_{OUT} \approx V_{DD}/2$  and  $C_L = 60\text{ pF}$ .



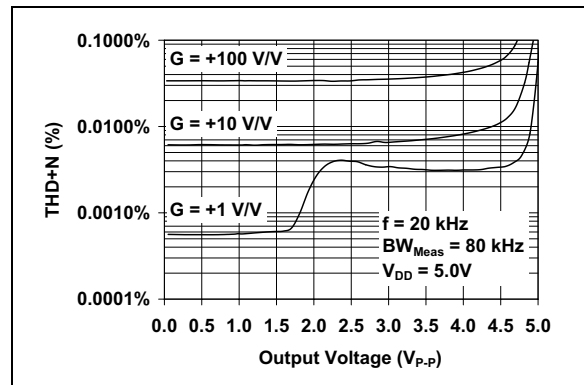
**FIGURE 2-25:** Slew Rate vs. Temperature.



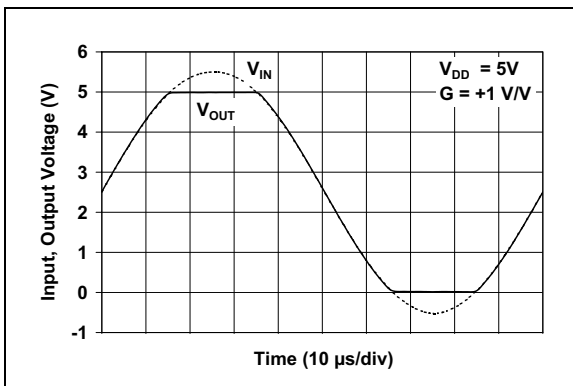
**FIGURE 2-28:** Maximum Output Voltage Swing vs. Frequency.



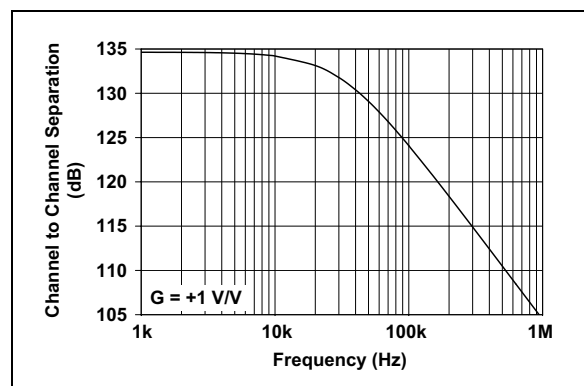
**FIGURE 2-26:** Total Harmonic Distortion plus Noise vs. Output Voltage with  $f = 1\text{ kHz}$ .



**FIGURE 2-29:** Total Harmonic Distortion plus Noise vs. Output Voltage with  $f = 20\text{ kHz}$ .



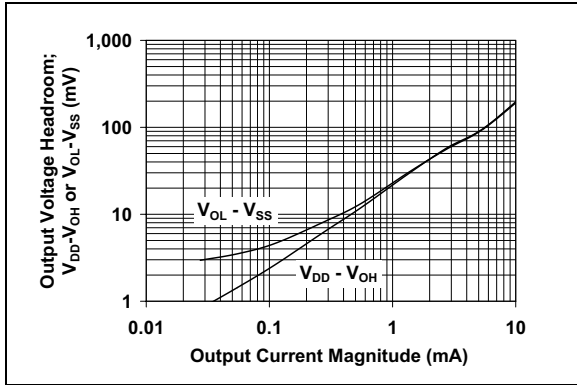
**FIGURE 2-27:** The MCP6021/2/3/4 family shows no phase reversal under overdrive.



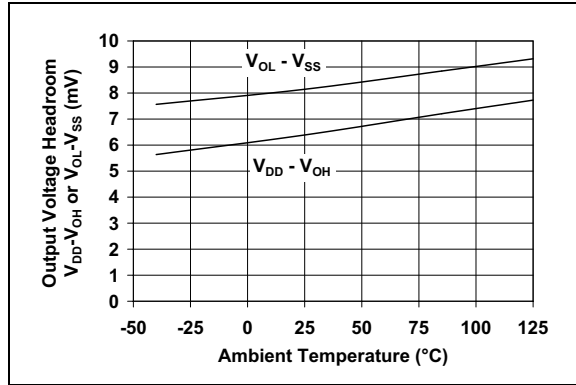
**FIGURE 2-30:** Channel-to-Channel Separation vs. Frequency (MCP6022 and MCP6024 only).

# MCP6021/2/3/4

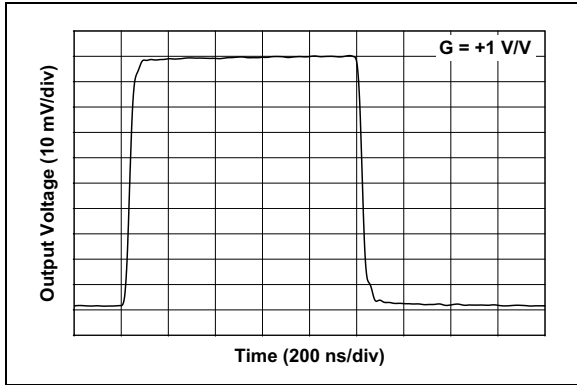
**Note:** Unless otherwise indicated,  $T_A = +25^\circ\text{C}$ ,  $V_{DD} = +2.5\text{V}$  to  $+5.5\text{V}$ ,  $V_{SS} = \text{GND}$ ,  $V_{CM} = V_{DD}/2$ ,  $R_L = 10\text{ k}\Omega$  to  $V_{DD}/2$ ,  $V_{OUT} \approx V_{DD}/2$  and  $C_L = 60\text{ pF}$ .



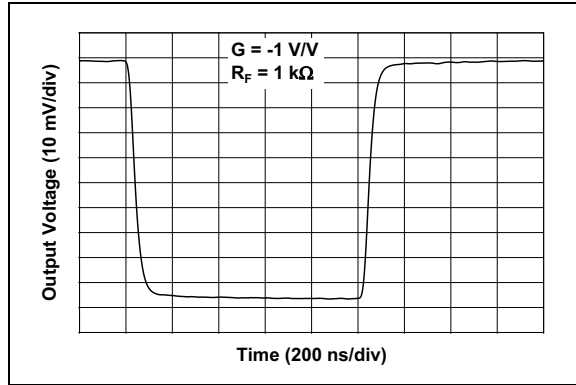
**FIGURE 2-31:** Output Voltage Headroom vs. Output Current.



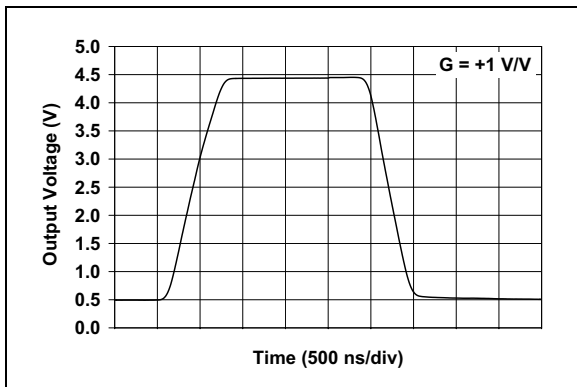
**FIGURE 2-34:** Output Voltage Headroom vs. Temperature.



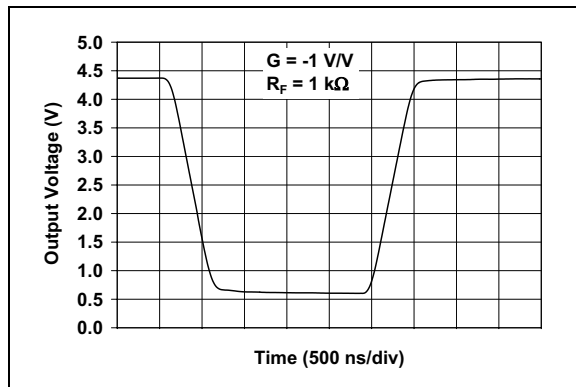
**FIGURE 2-32:** Small-Signal Non-inverting Pulse Response.



**FIGURE 2-35:** Small-Signal Inverting Pulse Response.

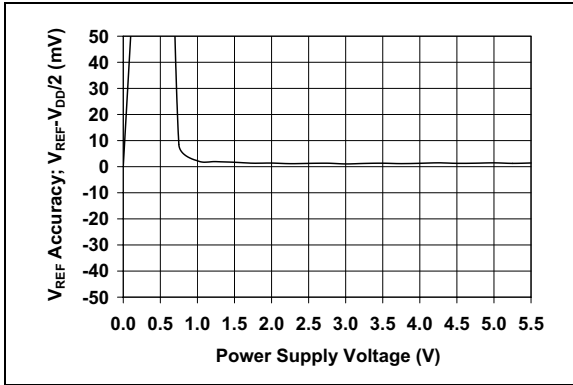


**FIGURE 2-33:** Large-Signal Non-inverting Pulse Response.

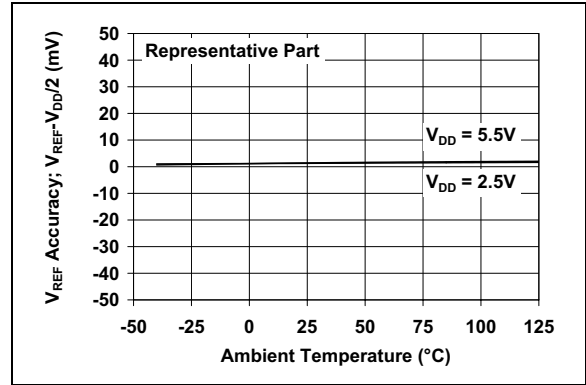


**FIGURE 2-36:** Large-Signal Inverting Pulse Response.

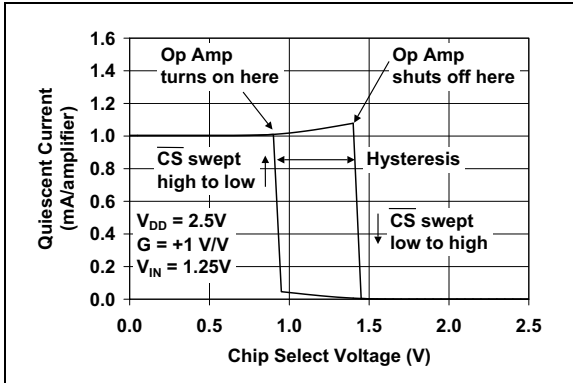
**Note:** Unless otherwise indicated,  $T_A = +25^\circ\text{C}$ ,  $V_{DD} = +2.5\text{V}$  to  $+5.5\text{V}$ ,  $V_{SS} = \text{GND}$ ,  $V_{CM} = V_{DD}/2$ ,  $R_L = 10\text{ k}\Omega$  to  $V_{DD}/2$ ,  $V_{OUT} \approx V_{DD}/2$  and  $C_L = 60\text{ pF}$ .



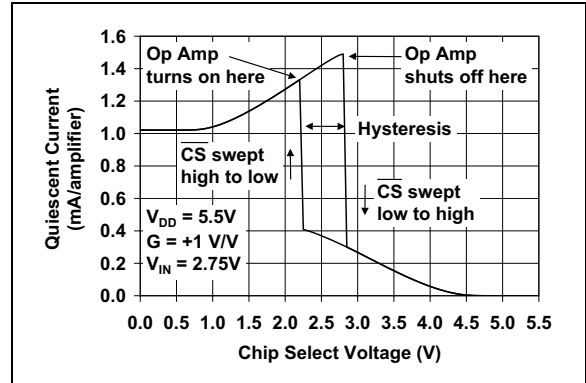
**FIGURE 2-37:**  $V_{REF}$  Accuracy vs. Supply Voltage (MCP6021 and MCP6023 only).



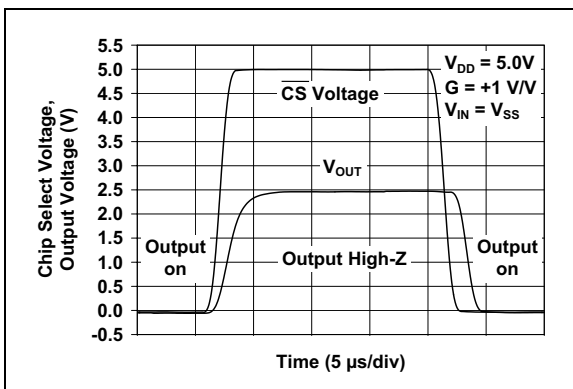
**FIGURE 2-40:**  $V_{REF}$  Accuracy vs. Temperature (MCP6021 and MCP6023 only).



**FIGURE 2-38:** Chip Select ( $\overline{CS}$ ) Hysteresis (MCP6023 only) with  $V_{DD} = 2.5\text{V}$ .



**FIGURE 2-41:** Chip Select ( $\overline{CS}$ ) Hysteresis (MCP6023 only) with  $V_{DD} = 5.5\text{V}$ .



**FIGURE 2-39:** Chip Select ( $\overline{CS}$ ) to Amplifier Output Response Time (MCP6023 only).

# MCP6021/2/3/4

## 3.0 APPLICATIONS INFORMATION

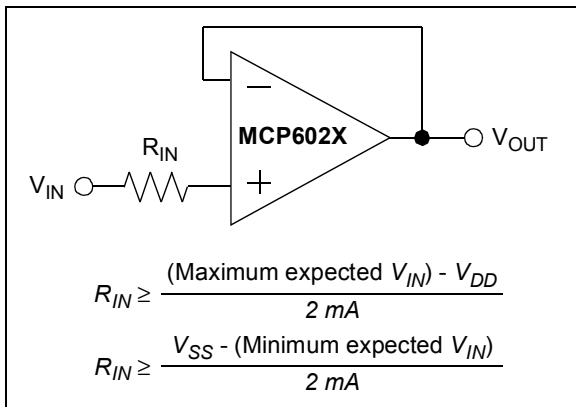
The MCP6021/2/3/4 family of operational amplifiers are fabricated on Microchip's state-of-the-art CMOS process. They are unity-gain stable and suitable for a wide range of general-purpose applications.

### 3.1 Rail-to-Rail Input

The MCP6021/2/3/4 amplifier family is designed to not exhibit phase inversion when the input pins exceed the supply voltages. Figure 2-27 shows an input voltage exceeding both supplies with no resulting phase inversion.

The input stage of the MCP6021/2/3/4 family of devices uses two differential input stages in parallel; one operates at low common-mode input voltage ( $V_{CM}$ ), while the other operates at high  $V_{CM}$ . With this topology, the device operates with  $V_{CM}$  up to 0.3V past either supply rail ( $V_{SS} - 0.3V$  to  $V_{DD} + 0.3V$ ) at 25°C. The amplifier input behaves linearly as long as  $V_{CM}$  is kept within the specified  $V_{CMR}$  limits. The input offset voltage is measured at both  $V_{CM} = V_{SS} - 0.3V$  and  $V_{DD} + 0.3V$  to ensure proper operation.

Input voltages that exceed the input voltage range ( $V_{CMR}$ ) can cause excessive current to flow in or out of the input pins. Current beyond  $\pm 2$  mA introduces possible reliability problems. Thus, applications that exceed this rating must externally limit the input current with an input resistor ( $R_{IN}$ ), as shown in Figure 3-1.



**FIGURE 3-1:**  $R_{IN}$  limits the current flow into an input pin.

### 3.2 Rail-to-Rail Output

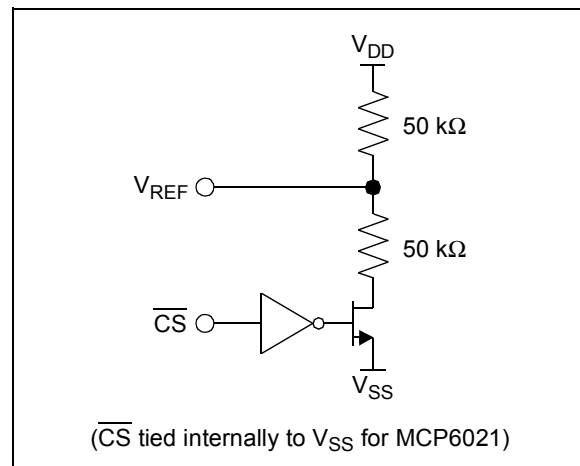
The Maximum Output Voltage Swing is the maximum swing possible under a particular output load. According to the specification table, the output can reach within 20 mV of either supply rail when  $R_L = 10$  k $\Omega$ . See Figure 2-31 and Figure 2-34 for more information concerning typical performance.

### 3.3 MCP6023 Chip Select ( $\overline{CS}$ )

The MCP6023 is a single amplifier with chip select ( $\overline{CS}$ ). When  $\overline{CS}$  is high, the supply current is less than 10 nA (typ) and travels from the  $\overline{CS}$  pin to  $V_{SS}$ , with the amplifier output being put into a high-impedance state. When  $\overline{CS}$  is low, the amplifier is enabled. If  $\overline{CS}$  is left floating, the amplifier will not operate properly. Figure 1-1 and Figure 2-39 show the output voltage and supply current response to a  $\overline{CS}$  pulse.

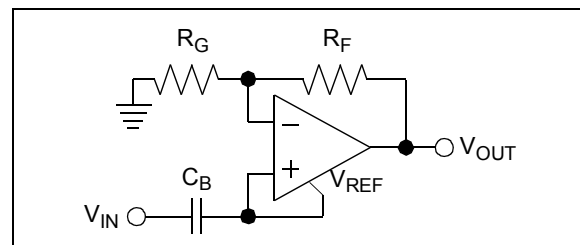
### 3.4 MCP6021 and MCP6023 Reference Voltage

The single op amps (MCP6021 and MCP6023) have an internal mid-supply reference voltage connected to the  $V_{REF}$  pin (see Figure 3-2). The MCP6021 has  $\overline{CS}$  internally tied to  $V_{SS}$ , which always keeps the op amp on and always provides a mid-supply reference. With the MCP6023, taking the  $\overline{CS}$  pin high conserves power by shutting down both the op amp and the  $V_{REF}$  circuitry. Taking the  $\overline{CS}$  pin low turns on the op amp and  $V_{REF}$  circuitry.



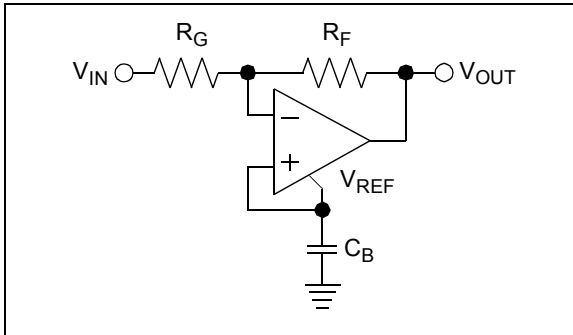
**FIGURE 3-2:** Simplified internal  $V_{REF}$  circuit (MCP6021 and MCP6023 only).

See Figure 3-3 for a non-inverting gain circuit using the internal mid-supply reference. The DC-blocking capacitor ( $C_B$ ) also reduces noise by coupling the op amp input to the source.



**FIGURE 3-3:** Non-inverting gain circuit using  $V_{REF}$  (MCP6021 and MCP6023 only).

To use the internal mid-supply reference for an inverting gain circuit, connect the  $V_{REF}$  pin to the non-inverting input, as shown in Figure 3-4. The capacitor  $C_B$  helps reduce power supply noise on the output.



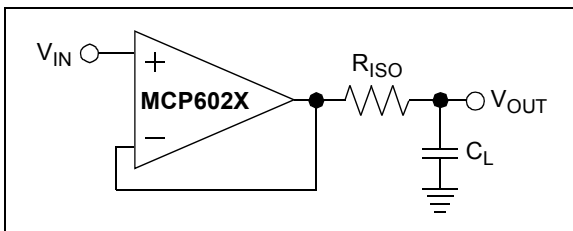
**FIGURE 3-4:** Inverting gain circuit using  $V_{REF}$  (MCP6021 and MCP6023 only).

If you don't need the mid-supply reference, leave the  $V_{REF}$  pin open.

### 3.5 Capacitive Loads

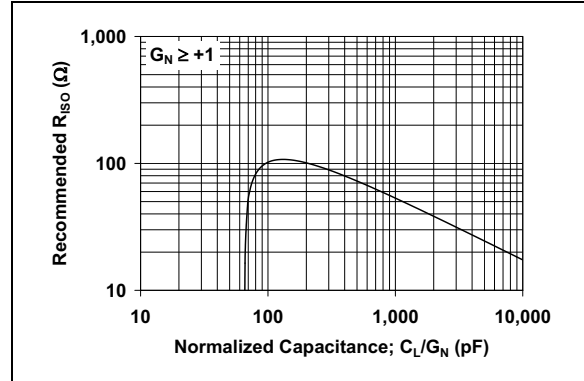
Driving large capacitive loads can cause stability problems for voltage feedback op amps. As the load capacitance increases, the feedback loop's phase margin decreases, and the closed loop bandwidth is reduced. This produces gain-peaking in the frequency response, with overshoot and ringing in the step response.

When driving large capacitive loads with these op amps (e.g., > 60 pF when  $G = +1$ ), a small series resistor at the output ( $R_{ISO}$  in Figure 3-5) improves the feedback loop's phase margin (stability) by making the load resistive at higher frequencies. The bandwidth will be generally lower than the bandwidth with no capacitive load.



**FIGURE 3-5:** Output resistor  $R_{ISO}$  stabilizes large capacitive loads.

Figure 3-6 gives recommended  $R_{ISO}$  values for different capacitive loads and gains. The x-axis is the normalized load capacitance ( $C_L/G_N$ ), where  $G_N$  is the circuit's noise gain. For non-inverting gains,  $G_N$  and the gain are equal. For inverting gains,  $G_N$  is  $1+|\text{Gain}|$  (e.g.,  $-1 \text{ V/V}$  gives  $G_N = +2 \text{ V/V}$ ).



**FIGURE 3-6:** Recommended  $R_{ISO}$  values for capacitive loads.

After selecting  $R_{ISO}$  for your circuit, double-check the resulting frequency response peaking and step response overshoot. Evaluation on the bench and simulations with the MCP6021/2/3/4 Spice macro model are very helpful. Modify  $R_{ISO}$ 's value until the response is reasonable.

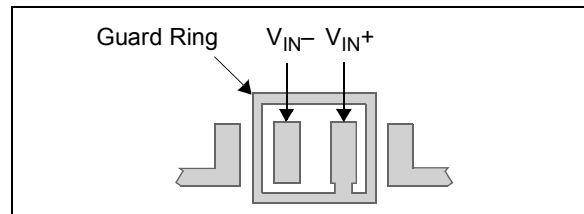
### 3.6 Supply Bypass

With this family of operational amplifiers, the power supply pin ( $V_{DD}$  for single supply) should have a local bypass capacitor (i.e., 0.01  $\mu\text{F}$  to 0.1  $\mu\text{F}$ ) within 2 mm for good, high-frequency performance. It also needs a bulk capacitor (i.e., 1  $\mu\text{F}$  or larger) within 100 mm to provide large, slow currents. This bulk capacitor can be shared with other parts.

### 3.7 PCB Surface Leakage

In applications where low input bias current is critical, PCB (printed circuit board) surface-leakage effects need to be considered. Surface leakage is caused by humidity, dust or other contamination on the board. Under low humidity conditions, a typical resistance between nearby traces is  $10^{12} \Omega$ . A 5V difference would cause 5 pA of current to flow, which is greater than the MCP6021/2/3/4 family's bias current at 25°C (1 pA, typ).

The easiest way to reduce surface leakage is to use a guard ring around sensitive pins (or traces). The guard ring is biased at the same voltage as the sensitive pin. An example of this type of layout is shown in Figure 3-7.



**FIGURE 3-7:** Example guard ring layout.

# MCP6021/2/3/4

1. Inverting (Figure 3-7) and Transimpedance Gain Amplifiers (convert current to voltage, such as photo detectors).
  - a. Connect the guard ring to the non-inverting input pin ( $V_{IN+}$ ). This biases the guard ring to the same reference voltage as the op amp's input (e.g.,  $V_{DD}/2$  or ground).
  - b. Connect the inverting pin ( $V_{IN-}$ ) to the input with a wire that does not touch the PCB surface.
2. Non-inverting Gain and Unity-Gain Buffer
  - a. Connect the guard ring to the inverting input pin ( $V_{IN-}$ ); this biases the guard ring to the common mode input voltage.
  - b. Connect the non-inverting pin ( $V_{IN+}$ ) to the input with a wire that does not touch the PCB surface.

## 3.8 High-Speed PCB Layout

Due to their speed capabilities, a little extra care in the PCB (Printed Circuit Board) layout can make a significant difference in the performance of these op amps. Good PCB layout techniques will help you achieve the performance shown in the Electrical Characteristics and Typical Performance Curves, while also helping you minimize EMC (Electro-Magnetic Compatibility) issues.

Use a solid ground plane and connect the bypass local capacitor(s) to this plane with minimal length traces. This cuts down inductive and capacitive crosstalk.

Separate digital from analog, low-speed from high-speed and low power from high power. This will reduce interference.

Keep sensitive traces short and straight. Separating them from interfering components and traces. This is especially important for high-frequency (low rise-time) signals.

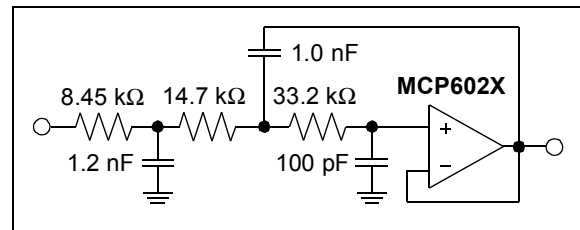
Sometimes it helps to place guard traces next to victim traces. They should be on both sides of the victim trace, and as close as possible. Connect the guard trace to ground plane at both ends, and in the middle for long traces.

Use coax cables (or low inductance wiring) to route signal and power to and from the PCB.

## 3.9 Typical Applications

### 3.9.1 A/D CONVERTER DRIVER AND ANTI-ALIASING FILTER

Figure 3-8 shows a third-order Butterworth filter that can be used as an A/D converter driver. It has a bandwidth of 20 kHz and a reasonable step response. It will work well for conversion rates of 80 ksp/s and greater (it has 29 dB attenuation at 60 kHz).

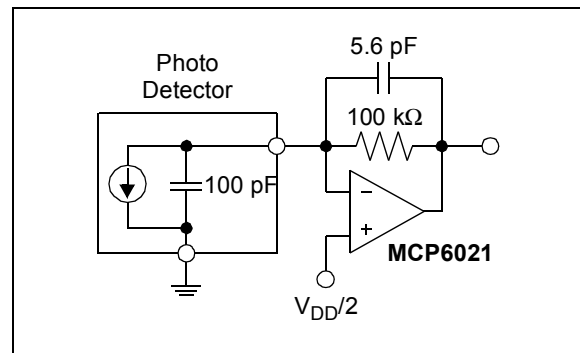


**FIGURE 3-8:** A/D converter driver and anti-aliasing filter with a 20 kHz cutoff frequency.

This filter can easily be adjusted to another bandwidth by multiplying all capacitors by the same factor. Alternatively, the resistors can all be scaled by another common factor to adjust the bandwidth.

### 3.9.2 OPTICAL DETECTOR AMPLIFIER

Figure 3-9 shows the MCP6021 op amp used as a transimpedance amplifier in a photo detector circuit. The photo detector looks like a capacitive current source, so the 100 kΩ resistor gains the input signal to a reasonable level. The 5.6 pF capacitor stabilizes this circuit and produces a flat frequency response with a bandwidth of 370 kHz.



**FIGURE 3-9:** Transimpedance amplifier for an optical detector.

## 4.0 DESIGN TOOLS

Microchip provides the basic design tools needed for the MCP6021/2/3/4 family of op amps.

### 4.1 SPICE Macro Model

The latest SPICE macro model for the MCP6021/2/3/4 op amps is available on our web site ([www.microchip.com](http://www.microchip.com)). This model is intended as an initial design tool that works well in the op amp's linear region of operation at room temperature. See the model file for information on its capabilities.

Bench testing is a very important part of any design and cannot be replaced with simulations. Also, simulation results using this macro model need to be validated by comparing them to the data sheet specs and plots.

### 4.2 FilterLab<sup>®</sup> Software

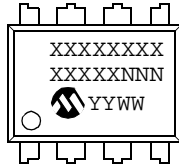
The FilterLab<sup>®</sup> software is an innovative tool that simplifies analog active filter (using op amps) design. Available at no cost from our web site (at [www.microchip.com](http://www.microchip.com)), the FilterLab software active filter design tool provides full schematic diagrams of the filter circuit with component values. It also outputs the filter circuit in SPICE format, which can be used with the Macro Model to simulate actual filter performance.

# MCP6021/2/3/4

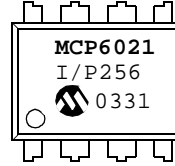
## 5.0 PACKAGING INFORMATION

### 5.1 Package Marking Information

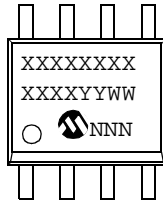
8-Lead PDIP (300 mil)



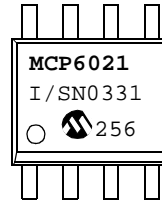
Example:



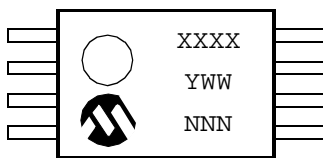
8-Lead SOIC (150 mil)



Example:



8-Lead TSSOP



Example:



<b>Legend:</b>	XX...X	Customer specific information*
	Y	Year code (last digit of calendar year)
	YY	Year code (last 2 digits of calendar year)
	WW	Week code (week of January 1 is week '01')
	NNN	Alphanumeric traceability code

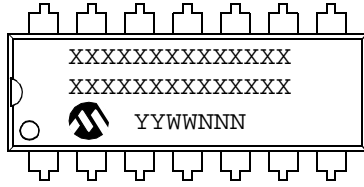
**Note:** In the event the full Microchip part number cannot be marked on one line, it will be carried over to the next line thus limiting the number of available characters for customer specific information.

\* Standard device marking consists of Microchip part number, year code, week code, and traceability code.

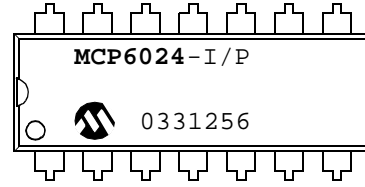


## Package Marking Information (Continued)

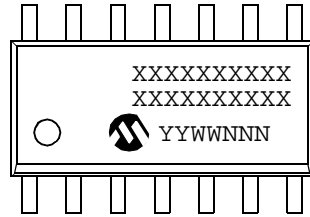
14-Lead PDIP (300 mil) (MCP6024)



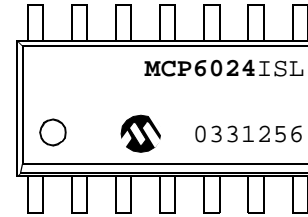
Example:



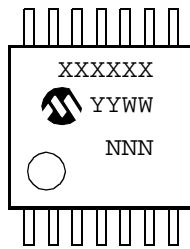
14-Lead SOIC (150 mil) (MCP6024)



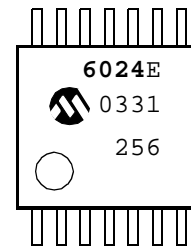
Example:



14-Lead TSSOP (MCP6024)

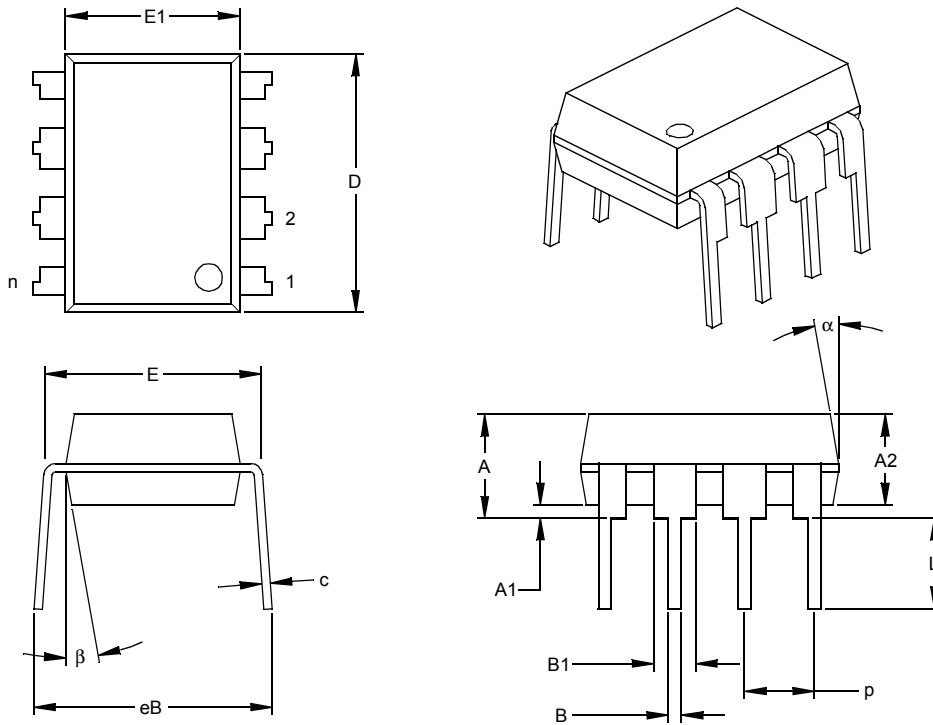


Example:



# MCP6021/2/3/4

## 8-Lead Plastic Dual In-line (P) – 300 mil (PDIP)



Units		INCHES*			MILLIMETERS		
Dimension	Limits	MIN	NOM	MAX	MIN	NOM	MAX
Number of Pins	n		8			8	
Pitch	p		.100			2.54	
Top to Seating Plane	A	.140	.155	.170	3.56	3.94	4.32
Molded Package Thickness	A2	.115	.130	.145	2.92	3.30	3.68
Base to Seating Plane	A1	.015			0.38		
Shoulder to Shoulder Width	E	.300	.313	.325	7.62	7.94	8.26
Molded Package Width	E1	.240	.250	.260	6.10	6.35	6.60
Overall Length	D	.360	.373	.385	9.14	9.46	9.78
Tip to Seating Plane	L	.125	.130	.135	3.18	3.30	3.43
Lead Thickness	c	.008	.012	.015	0.20	0.29	0.38
Upper Lead Width	B1	.045	.058	.070	1.14	1.46	1.78
Lower Lead Width	B	.014	.018	.022	0.36	0.46	0.56
Overall Row Spacing	§ eB	.310	.370	.430	7.87	9.40	10.92
Mold Draft Angle Top	α	5	10	15	5	10	15
Mold Draft Angle Bottom	β	5	10	15	5	10	15

\* Controlling Parameter

§ Significant Characteristic

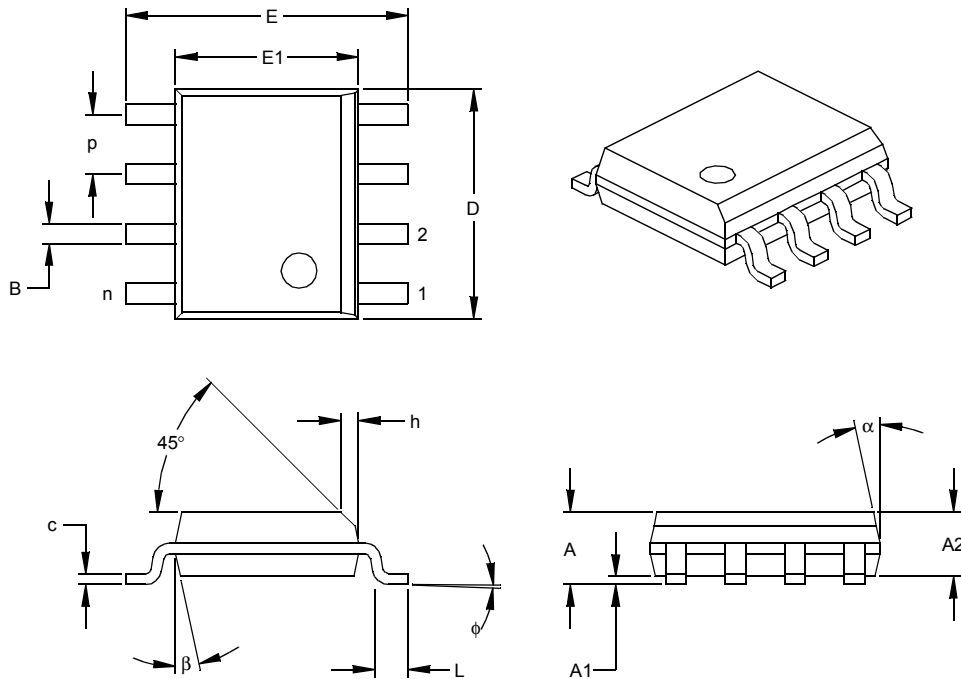
Notes:

Dimensions D and E1 do not include mold flash or protrusions. Mold flash or protrusions shall not exceed .010" (0.254mm) per side.

JEDEC Equivalent: MS-001

Drawing No. C04-018

## 8-Lead Plastic Small Outline (SN) – Narrow, 150 mil (SOIC)



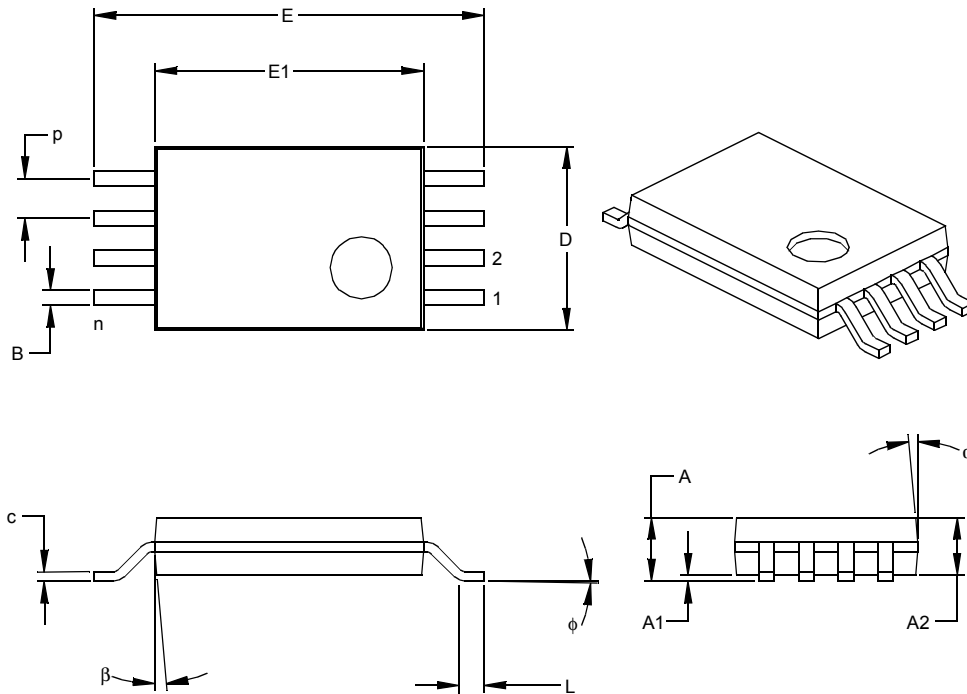
Dimension Limits	Units	INCHES*			MILLIMETERS		
		MIN	NOM	MAX	MIN	NOM	MAX
Number of Pins	n		8			8	
Pitch	p		.050			1.27	
Overall Height	A	.053	.061	.069	1.35	1.55	1.75
Molded Package Thickness	A2	.052	.056	.061	1.32	1.42	1.55
Standoff §	A1	.004	.007	.010	0.10	0.18	0.25
Overall Width	E	.228	.237	.244	5.79	6.02	6.20
Molded Package Width	E1	.146	.154	.157	3.71	3.91	3.99
Overall Length	D	.189	.193	.197	4.80	4.90	5.00
Chamfer Distance	h	.010	.015	.020	0.25	0.38	0.51
Foot Length	L	.019	.025	.030	0.48	0.62	0.76
Foot Angle	φ	0	4	8	0	4	8
Lead Thickness	c	.008	.009	.010	0.20	0.23	0.25
Lead Width	B	.013	.017	.020	0.33	0.42	0.51
Mold Draft Angle Top	α	0	12	15	0	12	15
Mold Draft Angle Bottom	β	0	12	15	0	12	15

\* Controlling Parameter  
 § Significant Characteristic

Notes:  
 Dimensions D and E1 do not include mold flash or protrusions. Mold flash or protrusions shall not exceed .010" (0.254mm) per side.  
 JEDEC Equivalent: MS-012  
 Drawing No. C04-057

# MCP6021/2/3/4

## 8-Lead Plastic Thin Shrink Small Outline (ST) – 4.4 mm (TSSOP)



Dimension Limits	Units	INCHES			MILLIMETERS*		
		MIN	NOM	MAX	MIN	NOM	MAX
Number of Pins	n		8			8	
Pitch	p		.026			0.65	
Overall Height	A			.043			1.10
Molded Package Thickness	A2	.033	.035	.037	0.85	0.90	0.95
Standoff §	A1	.002	.004	.006	0.05	0.10	0.15
Overall Width	E	.246	.251	.256	6.25	6.38	6.50
Molded Package Width	E1	.169	.173	.177	4.30	4.40	4.50
Molded Package Length	D	.114	.118	.122	2.90	3.00	3.10
Foot Length	L	.020	.024	.028	0.50	0.60	0.70
Foot Angle	φ	0	4	8	0	4	8
Lead Thickness	c	.004	.006	.008	0.09	0.15	0.20
Lead Width	B	.007	.010	.012	0.19	0.25	0.30
Mold Draft Angle Top	α	0	5	10	0	5	10
Mold Draft Angle Bottom	β	0	5	10	0	5	10

\* Controlling Parameter

§ Significant Characteristic

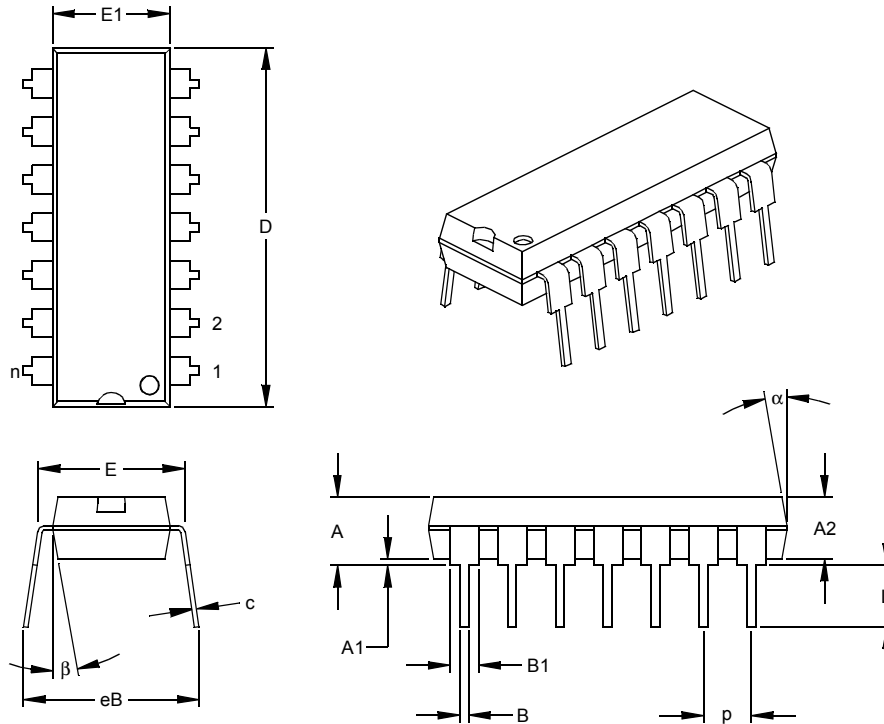
**Notes:**

Dimensions D and E1 do not include mold flash or protrusions. Mold flash or protrusions shall not exceed .005" (0.127mm) per side.

JEDEC Equivalent: MO-153

Drawing No. C04-086

## 14-Lead Plastic Dual In-line (P) – 300 mil (PDIP)



Units		INCHES*			MILLIMETERS		
Dimension Limits		MIN	NOM	MAX	MIN	NOM	MAX
Number of Pins	n		14			14	
Pitch	p		.100			2.54	
Top to Seating Plane	A	.140	.155	.170	3.56	3.94	4.32
Molded Package Thickness	A2	.115	.130	.145	2.92	3.30	3.68
Base to Seating Plane	A1	.015			0.38		
Shoulder to Shoulder Width	E	.300	.313	.325	7.62	7.94	8.26
Molded Package Width	E1	.240	.250	.260	6.10	6.35	6.60
Overall Length	D	.740	.750	.760	18.80	19.05	19.30
Tip to Seating Plane	L	.125	.130	.135	3.18	3.30	3.43
Lead Thickness	c	.008	.012	.015	0.20	0.29	0.38
Upper Lead Width	B1	.045	.058	.070	1.14	1.46	1.78
Lower Lead Width	B	.014	.018	.022	0.36	0.46	0.56
Overall Row Spacing	§ eB	.310	.370	.430	7.87	9.40	10.92
Mold Draft Angle Top	α	5	10	15	5	10	15
Mold Draft Angle Bottom	β	5	10	15	5	10	15

\* Controlling Parameter

§ Significant Characteristic

Notes:

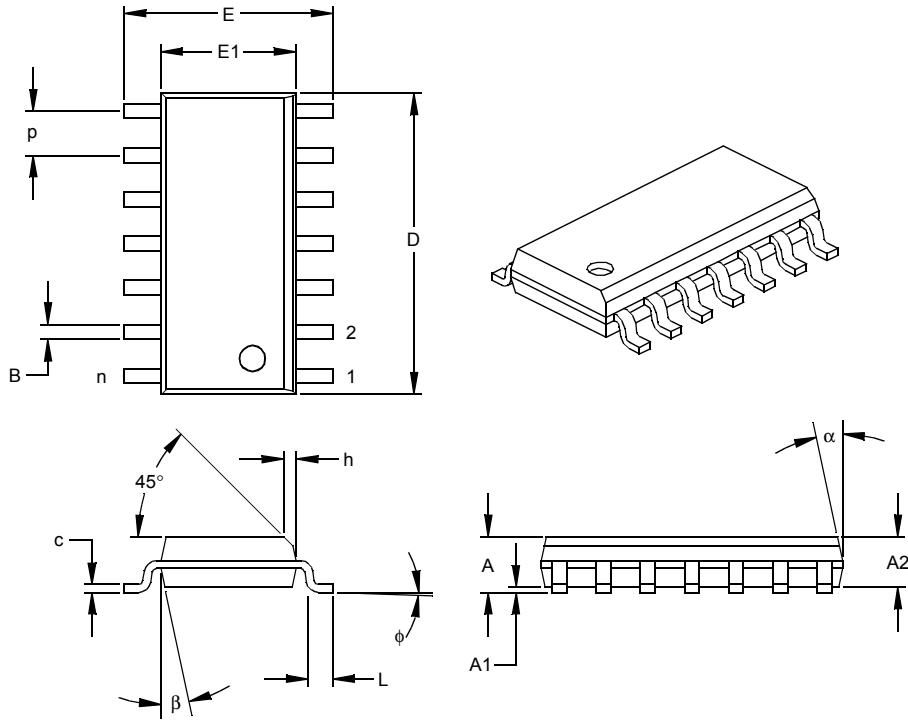
Dimensions D and E1 do not include mold flash or protrusions. Mold flash or protrusions shall not exceed .010" (0.254mm) per side.

JEDEC Equivalent: MS-001

Drawing No. C04-005

# MCP6021/2/3/4

## 14-Lead Plastic Small Outline (SL) – Narrow, 150 mil (SOIC)



Units		INCHES*			MILLIMETERS		
Dimension Limits		MIN	NOM	MAX	MIN	NOM	MAX
Number of Pins	n		14			14	
Pitch	p		.050			1.27	
Overall Height	A	.053	.061	.069	1.35	1.55	1.75
Molded Package Thickness	A2	.052	.056	.061	1.32	1.42	1.55
Standoff §	A1	.004	.007	.010	0.10	0.18	0.25
Overall Width	E	.228	.236	.244	5.79	5.99	6.20
Molded Package Width	E1	.150	.154	.157	3.81	3.90	3.99
Overall Length	D	.337	.342	.347	8.56	8.69	8.81
Chamfer Distance	h	.010	.015	.020	0.25	0.38	0.51
Foot Length	L	.016	.033	.050	0.41	0.84	1.27
Foot Angle	φ	0	4	8	0	4	8
Lead Thickness	c	.008	.009	.010	0.20	0.23	0.25
Lead Width	B	.014	.017	.020	0.36	0.42	0.51
Mold Draft Angle Top	α	0	12	15	0	12	15
Mold Draft Angle Bottom	β	0	12	15	0	12	15

\* Controlling Parameter

§ Significant Characteristic

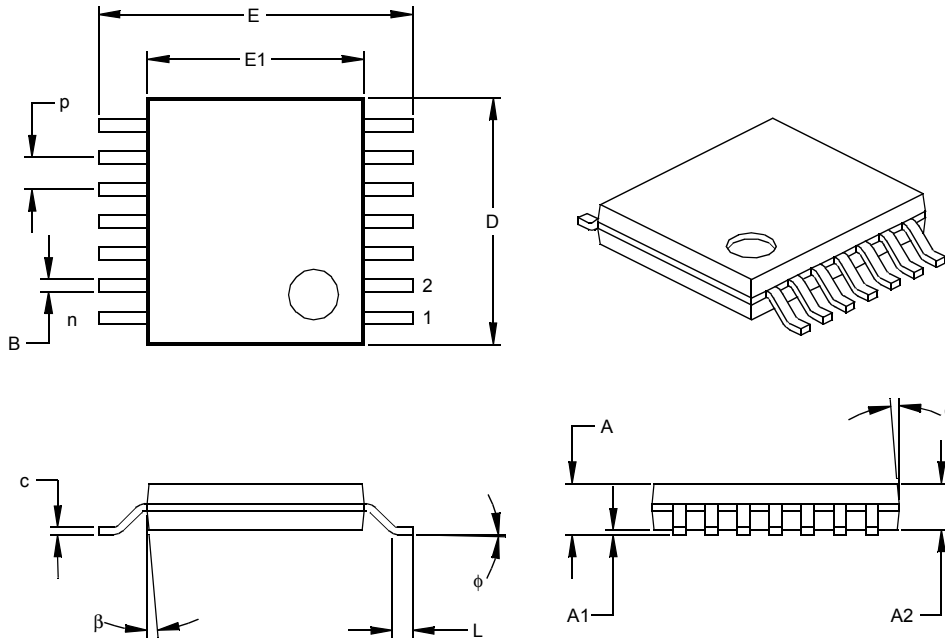
Notes:

Dimensions D and E1 do not include mold flash or protrusions. Mold flash or protrusions shall not exceed .010" (0.254mm) per side.

JEDEC Equivalent: MS-012

Drawing No. C04-065

## 14-Lead Plastic Thin Shrink Small Outline (ST) – 4.4 mm (TSSOP)



Units		INCHES			MILLIMETERS*		
Dimension Limits		MIN	NOM	MAX	MIN	NOM	MAX
Number of Pins	n		14			14	
Pitch	p		.026			0.65	
Overall Height	A			.043			1.10
Molded Package Thickness	A2	.033	.035	.037	0.85	0.90	0.95
Standoff §	A1	.002	.004	.006	0.05	0.10	0.15
Overall Width	E	.246	.251	.256	6.25	6.38	6.50
Molded Package Width	E1	.169	.173	.177	4.30	4.40	4.50
Molded Package Length	D	.193	.197	.201	4.90	5.00	5.10
Foot Length	L	.020	.024	.028	0.50	0.60	0.70
Foot Angle	φ	0	4	8	0	4	8
Lead Thickness	c	.004	.006	.008	0.09	0.15	0.20
Lead Width	B	.007	.010	.012	0.19	0.25	0.30
Mold Draft Angle Top	α	0	5	10	0	5	10
Mold Draft Angle Bottom	β	0	5	10	0	5	10

\* Controlling Parameter  
 § Significant Characteristic

**Notes:**

Dimensions D and E1 do not include mold flash or protrusions. Mold flash or protrusions shall not exceed .005" (0.127mm) per side.

JEDEC Equivalent: MO-153

Drawing No. C04-087

# MCP6021/2/3/4

---

NOTES:



## PRODUCT IDENTIFICATION SYSTEM

To order or obtain information, e.g., on pricing or delivery, refer to the factory or the listed sales office.

<u>PART NO.</u>	<u>X</u>	<u>/XX</u>	
Device	Temperature Range	Package	
Device:	MCP6021	CMOS Single Op Amp	
	MCP6021T	CMOS Single Op Amp (Tape and Reel for SOIC, TSSOP)	
	MCP6022	CMOS Dual Op Amp	
	MCP6022T	CMOS Dual Op Amp (Tape and Reel for SOIC and TSSOP)	
	MCP6023	CMOS Single Op Amp w/ $\overline{CS}$ Function	
	MCP6023T	CMOS Single Op Amp w/ $\overline{CS}$ Function (Tape and Reel for SOIC and TSSOP)	
	MCP6024	CMOS Quad Op Amp	
	MCP6024T	CMOS Quad Op Amp (Tape and Reel for SOIC and TSSOP)	
Temperature Range:	I	= -40°C to +85°C	
	E	= -40°C to +125°C	
Package:	P	= Plastic DIP (300 mil Body), 8-lead, 14-lead	
	SN	= Plastic SOIC (150mil Body), 8-lead	
	SL	= Plastic SOIC (150 mil Body), 14-lead	
	ST	= Plastic TSSOP, 8-lead, 14-lead	
<b>Examples:</b>			
a)	MCP6021-I/P:	Industrial temperature, PDIP package.	
b)	MCP6021-E/P:	Extended temperature, PDIP package.	
c)	MCP6021-E/SN:	Extended temperature, SOIC package.	
a)	MCP6022-I/P:	Industrial temperature, PDIP package.	
b)	MCP6022-E/P:	Extended temperature, PDIP package.	
c)	MCP6022T-E/ST:	Tape and Reel, Extended temperature, TSSOP package.	
a)	MCP6023-I/P:	Industrial temperature, PDIP package.	
b)	MCP6023-E/P:	Extended temperature, PDIP package.	
c)	MCP6023-E/SN:	Extended temperature, SOIC package.	
a)	MCP6024-I/SL:	Industrial temperature, SOIC package.	
b)	MCP6024-E/SL:	Extended temperature, SOIC package.	
c)	MCP6024T-E/ST:	Tape and Reel, Extended temperature, TSSOP package.	

## Sales and Support

### Data Sheets

Products supported by a preliminary Data Sheet may have an errata sheet describing minor operational differences and recommended workarounds. To determine if an errata sheet exists for a particular device, please contact one of the following:

1. Your local Microchip sales office
2. The Microchip Corporate Literature Center U.S. FAX: (480) 792-7277
3. The Microchip Worldwide Site ([www.microchip.com](http://www.microchip.com))

Please specify which device, revision of silicon and Data Sheet (include Literature #) you are using.

### Customer Notification System

Register on our web site ([www.microchip.com/cn](http://www.microchip.com/cn)) to receive the most current information on our products.

# MCP6021/2/3/4

---

NOTES:

---

---

**Note the following details of the code protection feature on Microchip devices:**

- Microchip products meet the specification contained in their particular Microchip Data Sheet.
- Microchip believes that its family of products is one of the most secure families of its kind on the market today, when used in the intended manner and under normal conditions.
- There are dishonest and possibly illegal methods used to breach the code protection feature. All of these methods, to our knowledge, require using the Microchip products in a manner outside the operating specifications contained in Microchip's Data Sheets. Most likely, the person doing so is engaged in theft of intellectual property.
- Microchip is willing to work with the customer who is concerned about the integrity of their code.
- Neither Microchip nor any other semiconductor manufacturer can guarantee the security of their code. Code protection does not mean that we are guaranteeing the product as "unbreakable."

Code protection is constantly evolving. We at Microchip are committed to continuously improving the code protection features of our products. Attempts to break microchip's code protection feature may be a violation of the Digital Millennium Copyright Act. If such acts allow unauthorized access to your software or other copyrighted work, you may have a right to sue for relief under that Act.

---

Information contained in this publication regarding device applications and the like is intended through suggestion only and may be superseded by updates. It is your responsibility to ensure that your application meets with your specifications. No representation or warranty is given and no liability is assumed by Microchip Technology Incorporated with respect to the accuracy or use of such information, or infringement of patents or other intellectual property rights arising from such use or otherwise. Use of Microchip's products as critical components in life support systems is not authorized except with express written approval by Microchip. No licenses are conveyed, implicitly or otherwise, under any intellectual property rights.

**Trademarks**

The Microchip name and logo, the Microchip logo, Accuron, dsPIC, KEELoQ, MPLAB, PIC, PICmicro, PICSTART, PRO MATE and PowerSmart are registered trademarks of Microchip Technology Incorporated in the U.S.A. and other countries.


AmpLab, FilterLab, microID, MXDEV, MXLAB, PICMASTER, SEEVAL and The Embedded Control Solutions Company are registered trademarks of Microchip Technology Incorporated in the U.S.A.

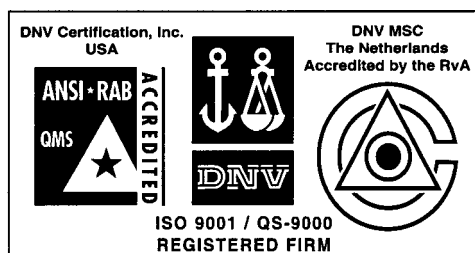
Application Maestro, dsPICDEM, dsPICDEM.net, ECAN, ECONOMONITOR, FanSense, FlexROM, fuzzyLAB, In-Circuit Serial Programming, ICSP, ICEPIC, microPort, Migratable Memory, MPASM, MPLIB, MPLINK, MPSIM, PICKit, PICDEM, PICDEM.net, PowerCal, PowerInfo, PowerMate, PowerTool, rLAB, rPIC, Select Mode, SmartSensor, SmartShunt, SmartTel and Total Endurance are trademarks of Microchip Technology Incorporated in the U.S.A. and other countries.

Serialized Quick Turn Programming (SQTP) is a service mark of Microchip Technology Incorporated in the U.S.A.

All other trademarks mentioned herein are property of their respective companies.

© 2003, Microchip Technology Incorporated, Printed in the U.S.A., All Rights Reserved.

 Printed on recycled paper.



*Microchip received QS-9000 quality system certification for its worldwide headquarters, design and wafer fabrication facilities in Chandler and Tempe, Arizona in July 1999 and Mountain View, California in March 2002. The Company's quality system processes and procedures are QS-9000 compliant for its PICmicro® 8-bit MCUs, KEELoQ® code hopping devices, Serial EEPROMs, microperipherals, non-volatile memory and analog products. In addition, Microchip's quality system for the design and manufacture of development systems is ISO 9001 certified.*



## WORLDWIDE SALES AND SERVICE

### AMERICAS

#### Corporate Office

2355 West Chandler Blvd.  
Chandler, AZ 85224-6199  
Tel: 480-792-7200  
Fax: 480-792-7277  
Technical Support: 480-792-7627  
Web Address: <http://www.microchip.com>

#### Atlanta

3780 Mansell Road, Suite 130  
Alpharetta, GA 30022  
Tel: 770-640-0034  
Fax: 770-640-0307

#### Boston

2 Lan Drive, Suite 120  
Westford, MA 01886  
Tel: 978-692-3848  
Fax: 978-692-3821

#### Chicago

333 Pierce Road, Suite 180  
Itasca, IL 60143  
Tel: 630-285-0071  
Fax: 630-285-0075

#### Dallas

4570 Westgrove Drive, Suite 160  
Addison, TX 75001  
Tel: 972-818-7423  
Fax: 972-818-2924

#### Detroit

Tri-Atria Office Building  
32255 Northwestern Highway, Suite 190  
Farmington Hills, MI 48334  
Tel: 248-538-2250  
Fax: 248-538-2260

#### Kokomo

2767 S. Albright Road  
Kokomo, IN 46902  
Tel: 765-864-8360  
Fax: 765-864-8387

#### Los Angeles

18201 Von Karman, Suite 1090  
Irvine, CA 92612  
Tel: 949-263-1888  
Fax: 949-263-1338

#### Phoenix

2355 West Chandler Blvd.  
Chandler, AZ 85224-6199  
Tel: 480-792-7966  
Fax: 480-792-4338

#### San Jose

2107 North First Street, Suite 590  
San Jose, CA 95131  
Tel: 408-436-7950  
Fax: 408-436-7955

#### Toronto

6285 Northam Drive, Suite 108  
Mississauga, Ontario L4V 1X5, Canada  
Tel: 905-673-0699  
Fax: 905-673-6509

### ASIA/PACIFIC

#### Australia

Suite 22, 41 Rawson Street  
Epping 2121, NSW  
Australia  
Tel: 61-2-9868-6733  
Fax: 61-2-9868-6755

#### China - Beijing

Unit 915  
Bei Hai Wan Tai Bldg.  
No. 6 Chaoyangmen Beidajie  
Beijing, 100027, No. China  
Tel: 86-10-85282100  
Fax: 86-10-85282104

#### China - Chengdu

Rm. 2401-2402, 24th Floor,  
Ming Xing Financial Tower  
No. 88 TIDU Street  
Chengdu 610016, China  
Tel: 86-28-86766200  
Fax: 86-28-86766599

#### China - Fuzhou

Unit 28F, World Trade Plaza  
No. 71 Wusi Road  
Fuzhou 350001, China  
Tel: 86-591-7503506  
Fax: 86-591-7503521

#### China - Hong Kong SAR

Unit 901-6, Tower 2, Metroplaza  
223 Hing Fong Road  
Kwai Fong, N.T., Hong Kong  
Tel: 852-2401-1200  
Fax: 852-2401-3431

#### China - Shanghai

Room 701, Bldg. B  
Far East International Plaza  
No. 317 Xian Xia Road  
Shanghai, 200051  
Tel: 86-21-6275-5700  
Fax: 86-21-6275-5060

#### China - Shenzhen

Rm. 1812, 18/F, Building A, United Plaza  
No. 5022 Binhe Road, Futian District  
Shenzhen 518033, China  
Tel: 86-755-82901380  
Fax: 86-755-8295-1393

#### China - Shunde

Room 401, Hongjian Building  
No. 2 Fengxiangnan Road, Ronggui Town  
Shunde City, Guangdong 528303, China  
Tel: 86-765-8395507 Fax: 86-765-8395571

#### China - Qingdao

Rm. B505A, Fullhope Plaza,  
No. 12 Hong Kong Central Rd.  
Qingdao 266071, China  
Tel: 86-532-5027355 Fax: 86-532-5027205

#### India

Divyasree Chambers  
1 Floor, Wing A (A3/A4)  
No. 11, O'Shaughnessy Road  
Bangalore, 560 025, India  
Tel: 91-80-2290061 Fax: 91-80-2290062

#### Japan

Benex S-1 6F  
3-18-20, Shinyokohama  
Kohoku-Ku, Yokohama-shi  
Kanagawa, 222-0033, Japan  
Tel: 81-45-471-6166 Fax: 81-45-471-6122

#### Korea

168-1, Youngbo Bldg. 3 Floor  
Samsung-Dong, Kangnam-Ku  
Seoul, Korea 135-882  
Tel: 82-2-554-7200 Fax: 82-2-558-5932 or  
82-2-558-5934

#### Singapore

200 Middle Road  
#07-02 Prime Centre  
Singapore, 188980  
Tel: 65-6334-8870 Fax: 65-6334-8850

#### Taiwan

Kaohsiung Branch  
30F - 1 No. 8  
Min Chuan 2nd Road  
Kaohsiung 806, Taiwan  
Tel: 886-7-536-4818  
Fax: 886-7-536-4803

#### Taiwan

Taiwan Branch  
11F-3, No. 207  
Tung Hua North Road  
Taipei, 105, Taiwan  
Tel: 886-2-2717-7175 Fax: 886-2-2545-0139

### EUROPE

#### Austria

Durisolstrasse 2  
A-4600 Wels  
Austria  
Tel: 43-7242-2244-399  
Fax: 43-7242-2244-393

#### Denmark

Regus Business Centre  
Lautrup høj 1-3  
Ballerup DK-2750 Denmark  
Tel: 45-4420-9895 Fax: 45-4420-9910

#### France

Parc d'Activite du Moulin de Massy  
43 Rue du Saule Trapu  
Batiment A - ler Etage  
91300 Massy, France  
Tel: 33-1-69-53-63-20  
Fax: 33-1-69-30-90-79

#### Germany

Steinheilstrasse 10  
D-85737 Ismaning, Germany  
Tel: 49-89-627-144-0  
Fax: 49-89-627-144-44

#### Italy

Via Quasimodo, 12  
20025 Legnano (MI)  
Milan, Italy  
Tel: 39-0331-742611  
Fax: 39-0331-466781

#### Netherlands

P. A. De Biesbosch 14  
NL-5152 SC Drunen, Netherlands  
Tel: 31-416-690399  
Fax: 31-416-690340

#### United Kingdom

505 Eskdale Road  
Winnersh Triangle  
Wokingham  
Berkshire, England RG41 5TU  
Tel: 44-118-921-5869  
Fax: 44-118-921-5820

07/28/03