

TDA8034HN

Smart card interface

Rev. 01 — 5 February 2010

Product data sheet

1. General description

The TDA8034HN is a cost-effective analog interface for asynchronous and synchronous smart cards operating at 5 V, 3 V or 1.8 V. Using few external components, the TDA8034HN provides all supply, protection and control functions between a smart card and the microcontroller.

2. Features

- Integrated circuit smart card interface in an HVQFN24 package
- 5 V, 3 V or 1.8 V smart card supply
- Very low power consumption in Deep Shutdown mode
- Three protected half-duplex bidirectional buffered I/O lines (C4, C7 and C8)
- V_{CC} regulation:
 - ◆ 5 V, 3 V or 1.8 V \pm 5 % using two low ESR multilayer ceramic capacitors: one of 220 nF and one of 470 nF
 - ◆ current spikes of 40 nA/s ($V_{CC} = 5$ V and 3 V) or 15 nA/s ($V_{CC} = 1.8$ V) up to 20 MHz, with controlled rise and fall times and filtered overload detection of approximately 120 mA
- Thermal and short-circuit protection for all card contacts
- Automatic activation and deactivation sequences triggered by a short-circuit, card take-off, overheating, falling V_{DD} , $V_{DD(INTF)}$ or V_{DDP}
- Enhanced card-side ElectroStatic Discharge (ESD) protection of > 6 kV
- External clock input up to 26 MHz connected to pin XTAL1
- Card clock generation up to 20 MHz using pins CLKDIV1 and CLKDIV2 with synchronous frequency changes of f_{xtal} , $\frac{1}{2} f_{xtal}$, $\frac{1}{4} f_{xtal}$ or $\frac{1}{8} f_{xtal}$
- Non-inverted control of pin RST using pin RSTIN
- Compatible with ISO 7816, NDS and EMV 4.2 payment systems
- Supply supervisor for killing spikes during power on and off:
 - ◆ using a fixed threshold
 - ◆ using an external resistor bridge with threshold adjustment
- Built-in debouncing on card presence contacts (typically 8 ms)
- Multiplexed status signal using pin OFFN

3. Applications

- Pay TV
- Electronic payment
- Identification
- Bank card readers

4. Quick reference data

Table 1. Quick reference data

$V_{DDP} = 5\text{ V}$; $V_{DD} = 3.3\text{ V}$; $V_{DD(INTF)} = 3.3\text{ V}$; $f_{xtal} = 10\text{ MHz}$; $GND = 0\text{ V}$; $T_{amb} = 25\text{ °C}$; unless otherwise specified.

Symbol	Parameter	Conditions	Min	Typ	Max	Unit		
Supply								
V_{DDP}	power supply voltage	pin V_{DDP} ; regulator input						
		$V_{CC} = 5\text{ V}$	4.85	5	5.5	V		
		$V_{CC} = 3\text{ V}$ and 1.8 V	3	3.3	5.5	V		
V_{DD}	supply voltage	pin V_{DD}	2.7	3.3	3.6	V		
$V_{DD(INTF)}$	interface supply voltage	pin $V_{DD(INTF)}$	1.6	3.3	$V_{DD} + 0.3$	V		
I_{DD}	supply current	Shutdown mode	-	-	35	μA		
		Deep Shutdown mode	-	-	12	μA		
I_{DDP}	power supply current	Shutdown mode; f_{xtal} stopped	-	-	5	μA		
		Active mode; $f_{CLK} = \frac{1}{2} f_{xtal}$; no load	-	-	1.5	mA		
$I_{DD(INTF)}$	interface supply current	Shutdown mode	-	-	6	μA		
Card supply voltage: pin V_{CC}^[1]								
V_{CC}	supply voltage	active mode; $I_{CC} < 65\text{ mA DC}$						
		5 V card	4.75	5.0	5.25	V		
		3 V card	2.85	3.05	3.15	V		
		1.8 V card	1.71	1.83	1.89	V		
		active mode; current pulses of 40 nA/s at $I_{CC} < 200\text{ mA}$; $t < 400\text{ ns}$						
		5 V card	4.65	5.0	5.25	V		
		3 V card	2.76	-	3.20	V		
		active mode; current pulses of 15 nA/s at $I_{CC} < 200\text{ mA}$, $t < 400\text{ ns}$; 1.8 V card	1.66	-	1.94	V		
		$V_{ripple(p-p)}$	peak-to-peak ripple voltage	from 20 kHz to 200 MHz	-	-	350	mV
		I_{CC}	supply current	$V_{CC} = 0\text{ V}$ to 5 V, 3 V or 1.8 V	-	-	65	mA
General								
t_{deact}	deactivation time	see Figure 8 on page 11	35	90	250	μs		
P_{tot}	total power dissipation	$T_{amb} = -25\text{ °C}$ to $+85\text{ °C}$	-	-	0.25	W		
T_{amb}	ambient temperature		-25	-	+85	$^{\circ}\text{C}$		

[1] To meet these specifications, V_{CC} should be decoupled to pin GND using two ceramic multilayer capacitors of low ESR with values of either 100 nF or one 220 nF and one 470 nF.

5. Ordering information

Table 2. Ordering information

Type number	Package		Description	Version
	Name			
TDA8034HN	HVQFN24		plastic thermal enhanced very thin quad flat package; no leads; 24 terminals; body 4 × 4 × 0.85 mm	SOT616-1

6. Block diagram

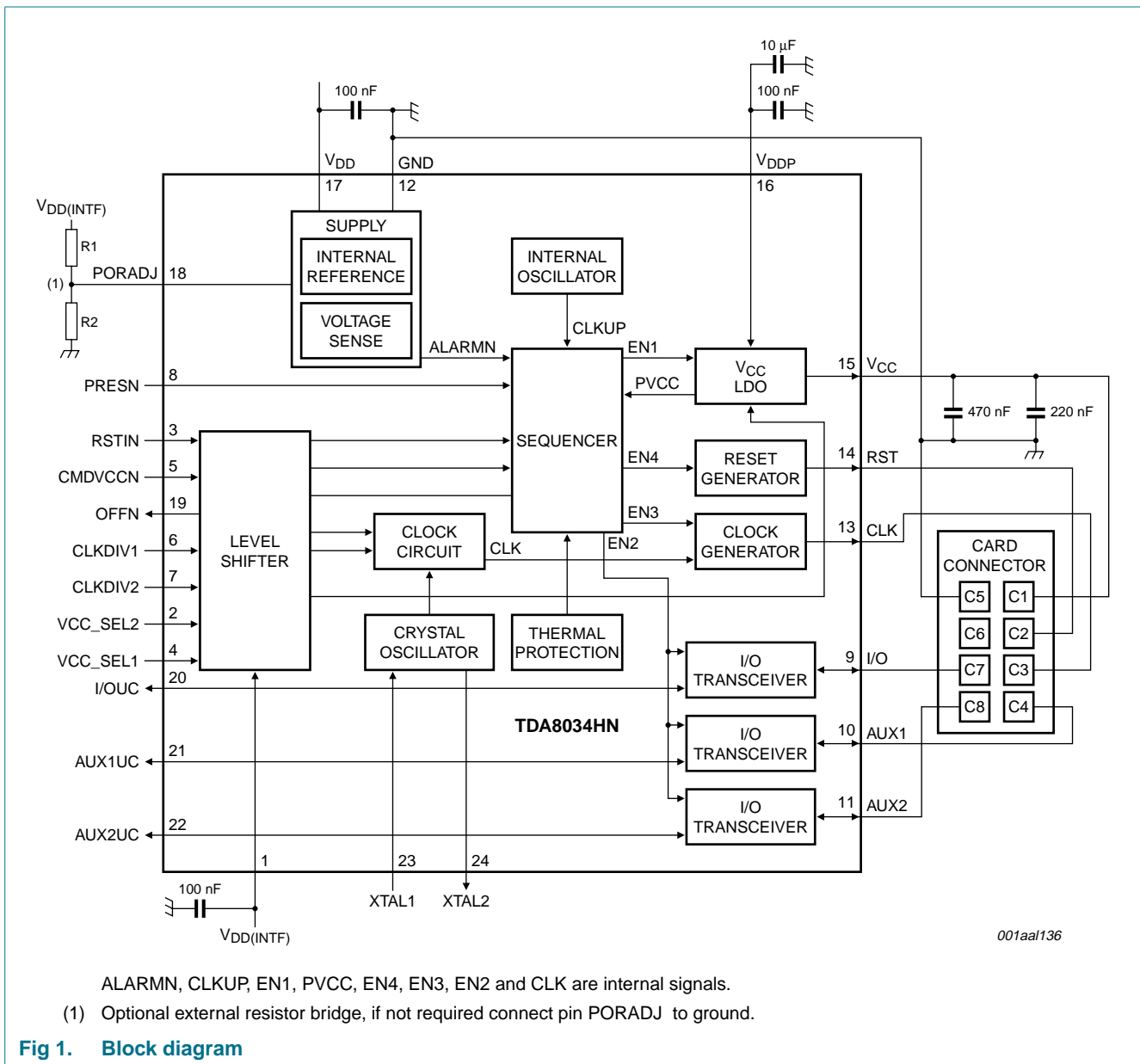

ALARMN, CLKUP, EN1, PVCC, EN4, EN3, EN2 and CLK are internal signals.

(1) Optional external resistor bridge, if not required connect pin $PORADJ$ to ground.

7. Pinning information

7.1 Pinning

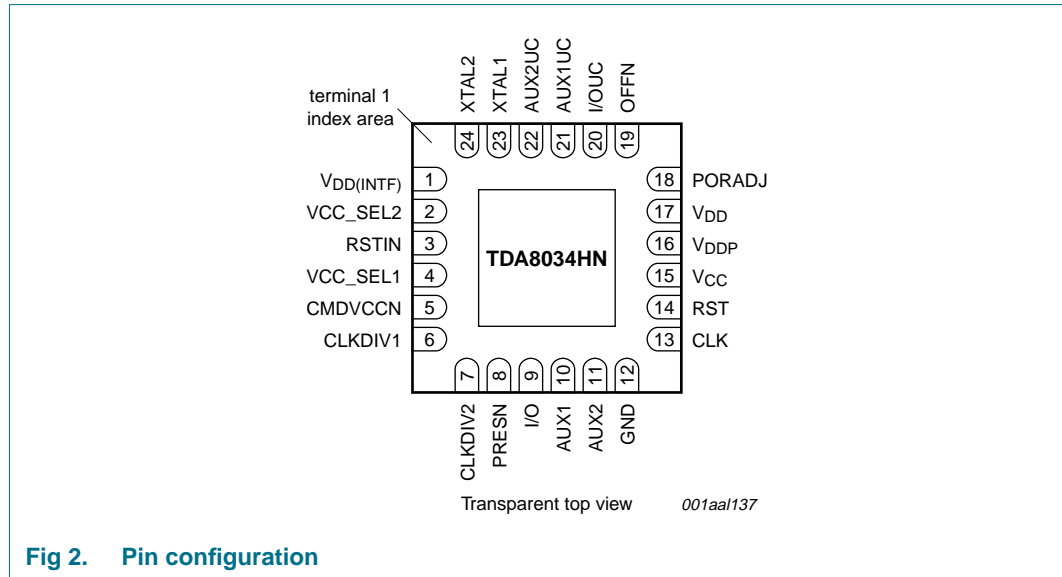

Fig 2. Pin configuration

7.2 Pin description

Table 3. Pin description

Symbol	Pin	Supply	Type ^[1]	Description
V _{DD} (INTF)	1	V _{DD} (INTF)	P	interface supply voltage
VCC_SEL2	2	V _{DD} (INTF)	I	5 V or 3 V V _{CC} voltage selection control signal: active LOW: V _{CC} = 3 V when pin VCC_SEL1 is HIGH active HIGH: V _{CC} = 5 V
RSTIN	3	V _{DD} (INTF)	I	microcontroller card reset input; active HIGH
VCC_SEL1	4	V _{DD} (INTF)	I	1.8 V V _{CC} voltage selection control signal: active LOW: V _{CC} = 1.8 V active HIGH: disables 1.8 V selection
CMDVCCN	5	V _{DD} (INTF)	I	microcontroller start activation sequence input; active LOW
CLKDIV1	6	V _{DD} (INTF)	I	sets the clock frequency on pin CLK in association with pin CLKDIV2; see Table 4
CLKDIV2	7	V _{DD} (INTF)	I	sets the clock frequency on pin CLK in association with pin CLKDIV1; see Table 4
PRESN	8	V _{DD} (INTF)	I	card presence contact input; active LOW ^[2]
I/O	9	V _{CC}	I/O	card input/output data line (C7) ^[3]
AUX1	10	V _{CC}	I/O	auxiliary card input/output data line (C4) ^[3]
AUX2	11	V _{CC}	I/O	auxiliary card input/output data line (C8) ^[3]
GND	12	-	G	ground
CLK	13	V _{CC}	O	card clock (C3)
RST	14	V _{CC}	O	card reset (C2)
V _{CC}	15	V _{CC}	P	card supply (C1); decouple to pin GND using one 470 nF capacitor close to pin V _{CC} and one 220 nF capacitor close to card socket contact C1 with an ESR < 100 mΩ

Table 3. Pin description ...continued

Symbol	Pin	Supply	Type ^[1]	Description
V _{DDP}	16	V _{DDP}	P	low-dropout regulator input supply voltage
V _{DD}	17	V _{DD}	P	digital supply voltage
PORADJ	18	V _{DD(INTF)}	I	power-on reset threshold adjustment input using an optional external resistor bridge
OFFN	19	V _{DD(INTF)}	O	NMOS interrupt to microcontroller ^[4] ; active LOW; see Section 8.10 on page 11
I/OUC	20	V _{DD(INTF)}	I/O	microcontroller input/output data line ^[3]
AUX1UC	21	V _{DD(INTF)}	I/O	auxiliary microcontroller input/output data line ^[3]
AUX2UC	22	V _{DD(INTF)}	I/O	auxiliary microcontroller input/output data line ^[3]
XTAL1	23	V _{DD}	I	crystal connection input
XTAL2	24	V _{DD}	O	crystal connection output

[1] I = input, O = output, I/O = input/output, G = ground and P = power supply.

[2] If pin PRESN is HIGH, the card is considered to be present. During card insertion, debouncing can occur on these signals. To counter this, the TDA8034HN has a built-in debouncing timer (typically 8 ms).

[3] Uses an internal 11 kΩ pull-up resistor connected to pin V_{CC}.

[4] Uses an internal 20 kΩ pull-up resistor connected to pin V_{DD}.

8. Functional description

Remark: Throughout this document the ISO 7816 terminology conventions have been adhered to and it is assumed that the reader is familiar with these.

8.1 Power supplies

The power supply voltage ranges are as follows:

- V_{DDP}: 4.85 V to 5.5 V when VCC_SEL2 is HIGH (V_{CC} = 5 V)
- V_{DDP}: 3 V to 5.5 V when VCC_SEL2 is LOW (V_{CC} = 3 V) or when VCC_SEL1 is LOW (V_{CC} = 1.8 V)
- V_{DD}: 2.7 V to 3.6 V

All interface signals to the system controller are referenced to V_{DD(INTF)}. All card contacts remain inactive during power up or power down. After powering up the device, pin OFFN remains LOW until pin CMDVCCN is set HIGH and pin PRESN is LOW. During power down, pin OFFN goes LOW when V_{DDP} falls below the falling threshold voltage (V_{th}).

The internal oscillator frequency (f_{osc(int)}) is only used during the activation sequences. When the card is not activated (pin CMDVCCN is HIGH), the internal oscillator is in low frequency mode to reduce power consumption.

This device has a Low Drop-Off (LDO) voltage regulator connected to pin V_{CC}, and is used instead of a DC-to-DC converter. It ensures a minimum V_{CC} of 4.75 V and that the power supply voltage on pin V_{DDP} does not fall below 4.85 V when pin VCC_SEL2 is HIGH, for a maximum load current of 65 mA.

8.2 Voltage supervisor

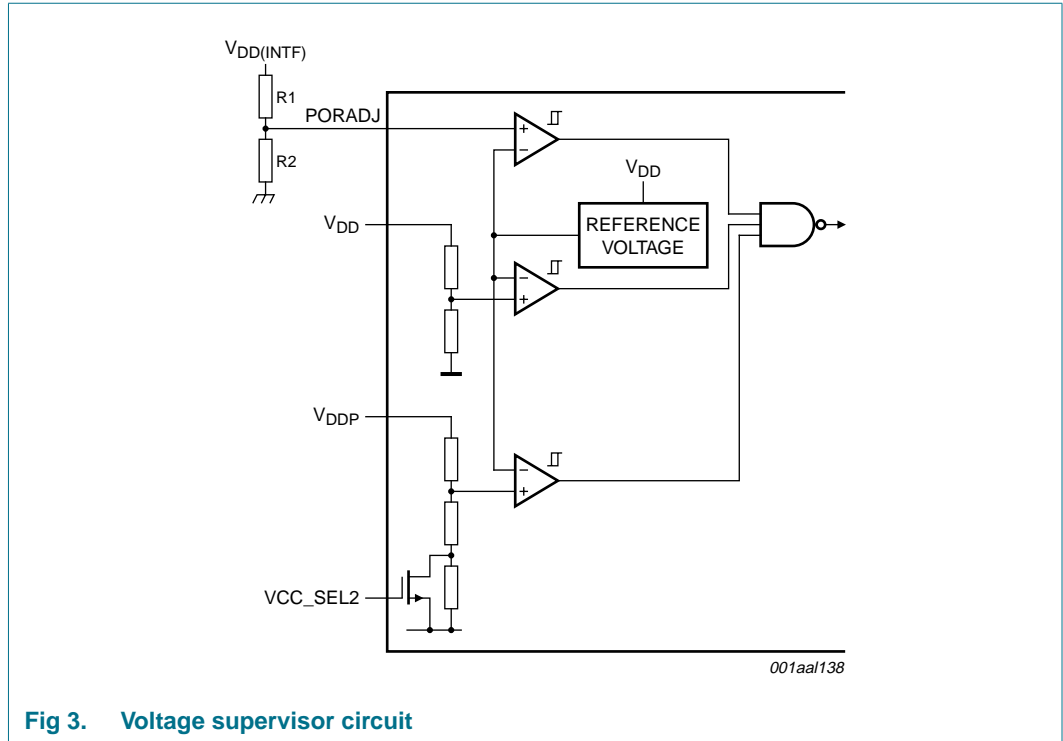

Fig 3. Voltage supervisor circuit

The voltage supervisor monitors the voltage of the V_{DDP} , V_{DD} and $V_{DD(INTF)}$ supplies providing both Power-On Reset (POR) and supply drop-out detection during a card session. The supervisor threshold voltages for V_{DDP} and V_{DD} are set internally, and for $V_{DD(INTF)}$ externally by pin PORADJ. As long as V_{DD} is less than $V_{th} + V_{hys}$, the IC remains inactive irrespective of the command line levels. After V_{DD} has reached a level higher than $V_{th} + V_{hys}$, the IC remains inactive for the duration of t_w . The output of the supervisor is sent to a digital controller in order to reset the TDA8034HN. This defined reset pulse of approximately 8 ms, i.e. ($t_w = 1024 \times \frac{1}{f_{osc(int)low}}$), is used internally to maintain the IC in the Shutdown mode during the supply voltage power on; see Figure 4. A deactivation sequence is performed when either V_{DD} , V_{DDP} or $V_{DD(INTF)}$ falls below V_{th} .

Remark: $f_{osc(int)low}$ is the low frequency (or inactive) mode of the defined $f_{osc(int)}$ parameter.

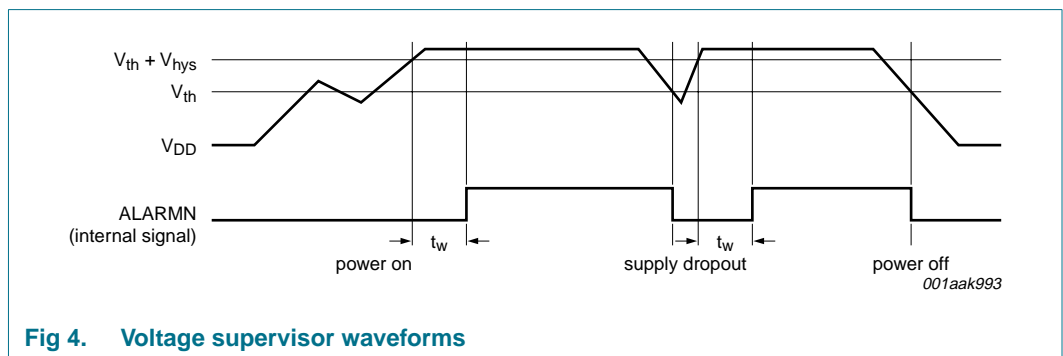
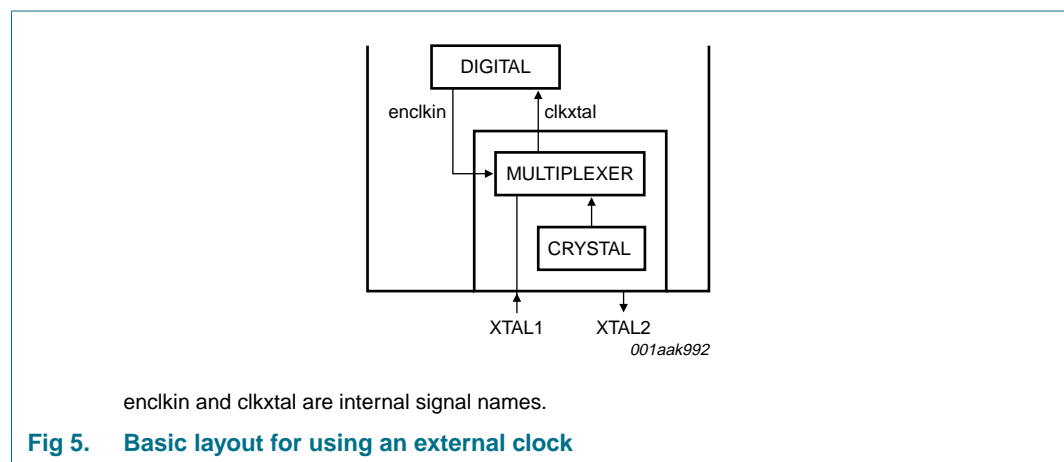

Fig 4. Voltage supervisor waveforms

8.3 Clock circuits

The clock signal from pin CLK to the card is either supplied by an external clock signal connected to pin XTAL1 or generated using a crystal connected between pins XTAL1 and XTAL2. The TDA8034HN automatically detects if an external clock is connected to XTAL1, eliminating the need for a separate pin to select the clock source.

Automatic clock source detection is performed on each activation command (falling edge of the signal on pin CMDVCCN). The presence of an external clock on pin XTAL1 is checked during a time window defined by the internal oscillator. If a clock is detected, the internal crystal oscillator is stopped. If a clock is not detected, the internal crystal oscillator is started. When an external clock is used, it is mandatory that the clock is applied to pin XTAL1 before the falling edge of the signal on pin CMDVCCN.



The clock frequency is selected using pins CLKDIV1 and CLKDIV2 to be either f_{xtal} , $\frac{1}{2} f_{xtal}$ or $\frac{1}{4} f_{xtal}$ or $\frac{1}{8} f_{xtal}$ as shown in [Table 4](#).

Remark: The levels on both pins must not be allowed to change simultaneously but should be separated by a minimum of 10 ns.

The frequency change is synchronous and as such during transition, no pulse is shorter than 45 % of the smallest period. In addition, only the first and last clock pulse around the change has the correct width. When dynamically changing the frequency, the modification is only effective after 10 clock periods on pin XTAL1.

The duty cycle of f_{xtal} on pin CLK should be between 45 % and 55 %. If an external clock is connected to pin XTAL1, its duty cycle must be between 48 % and 52 %.

When the frequency of the clock signal on pin CLK is either f_{xtal} , $\frac{1}{2} f_{xtal}$, $\frac{1}{4} f_{xtal}$ or $\frac{1}{8} f_{xtal}$, the frequency dividers guarantee a duty cycle between 45 % and 55 %.

Table 4. Clock configuration

Pin CLKDIV1 level	Pin CLKDIV2 level	Pin CLK frequency
LOW	LOW	$\frac{1}{8} f_{xtal}$
LOW	HIGH	$\frac{1}{4} f_{xtal}$
HIGH	HIGH	$\frac{1}{2} f_{xtal}$
HIGH	LOW	f_{xtal}

8.4 Input and output circuits

When pins I/O and I/OUC are pulled HIGH using an 11 k Ω resistor between pins I/O and V_{CC} and/or between pins I/OUC and V_{DD(INTF)}, both lines enter the idle state. Pin I/O is referenced to V_{CC} and pin I/OUC to V_{DD(INTF)}, thus allowing operation at V_{CC} \neq V_{DD(INTF)}.

The first side on which a falling edge occurs becomes the master. An anti-latch circuit disables falling edge detection on the other line, making it the slave. After a time delay t_d, the logic 0 present on the master-side is sent to the slave-side. When the master-side returns logic 1, the slave-side sends logic 1 during time delay (t_{w(pu)}). After this sequence, both master and slave sides return to their idle states.

The active pull-up feature ensures fast LOW-to-HIGH transitions making the TDA8034HN capable of delivering more than 1 mA, up to an output voltage of 0.9V_{CC}, at a load of 80 pF. At the end of the active pull-up pulse, the output voltage is dependent on the internal pull-up resistor value and load current. The current sent to and received from the card's I/O lines is limited to 15 mA at a maximum frequency of 1 MHz.

8.5 Shutdown mode

After a power-on reset, if pin CMDVCCN is HIGH, the circuit enters the Shutdown mode, ensuring only the minimum number of circuits are active while the TDA8034HN waits for the microcontroller to start a session.

- all card contacts are inactive. The impedance between the contacts and GND is approximately 200 Ω .
- pins I/OUC, AUX1UC and AUX2UC are high-impedance using the 11 k Ω pull-up resistor connected to V_{DD(INTF)}
- the voltage generators are stopped
- the voltage supervisor is active
- the internal oscillator runs at its lowest frequency (f_{osc(int)low})

8.6 Deep shutdown mode

When the smart card reader is inactive, the TDA8034HN will enter Deep shutdown mode if pin CMDVCCN is forced HIGH and pins VCC_SEL1 and VCC_SEL2 are LOW. In Deep shutdown mode, all circuits are disabled and pin OFFN follows the status of pin PRESN. Changing the status of either pin CMDVCCN, VCC_SEL1 or VCC_SEL2 exits Deep shutdown mode; see [Figure 6](#).

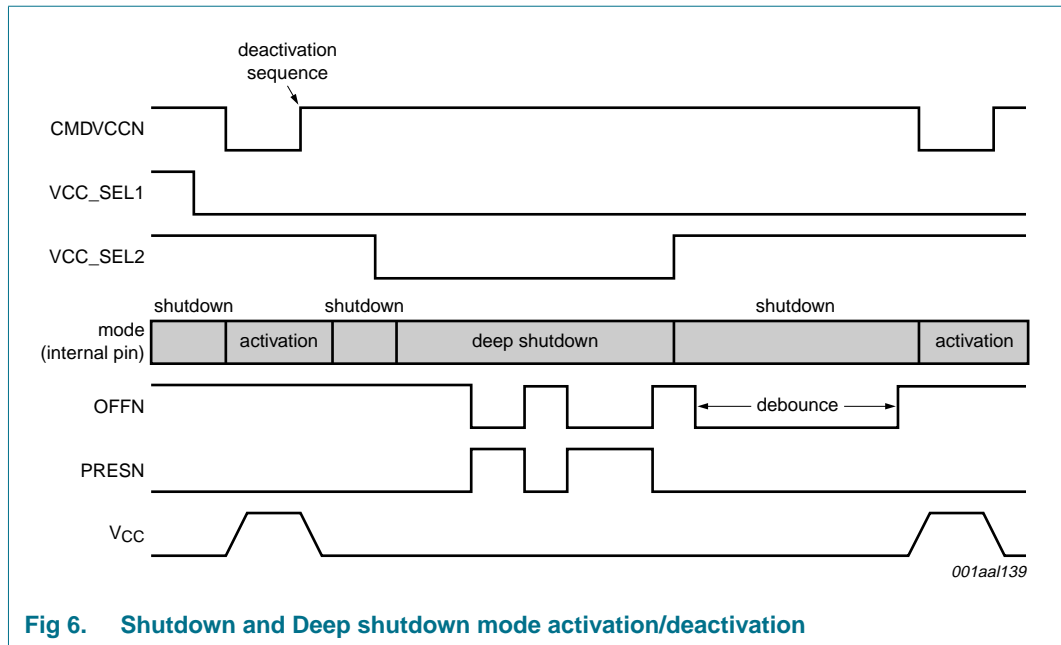

Fig 6. Shutdown and Deep shutdown mode activation/deactivation

8.7 Activation sequence

The following device activation sequence is applied when using an external clock; see [Figure 7](#):

1. Pin CMDVCCN is pulled LOW (t0).
2. The internal oscillator is triggered (t0).
3. The internal oscillator changes to high frequency (t1).
4. V_{CC} rises from either 0 V to 3 V or 0 V to 5 V on a controlled slope (t2).
5. Pins I/OUC, AUX1UC and AUX2UC are driven HIGH (t3).
6. The clock on pin CLK is applied to the C3 contact (t4).
7. Pin RST is enabled (t5).

Calculation of the time delays is as follows:

- $t1 = t0 + 384 \times \frac{1}{f_{osc(int)low}}$
- $t2 = t1$
- $t3 = t1 + 17T / 2$
- $t4 = \text{driven by host controller; } > t3 \text{ and } < t5$
- $t5 = t1 + 23T / 2$

Remark: The value of period T is 64 times the period interval of the internal oscillator at high frequency ($\frac{1}{f_{osc(int)high}}$); t3 is called t_{d(start)} and t5 is called t_{d(end)}.

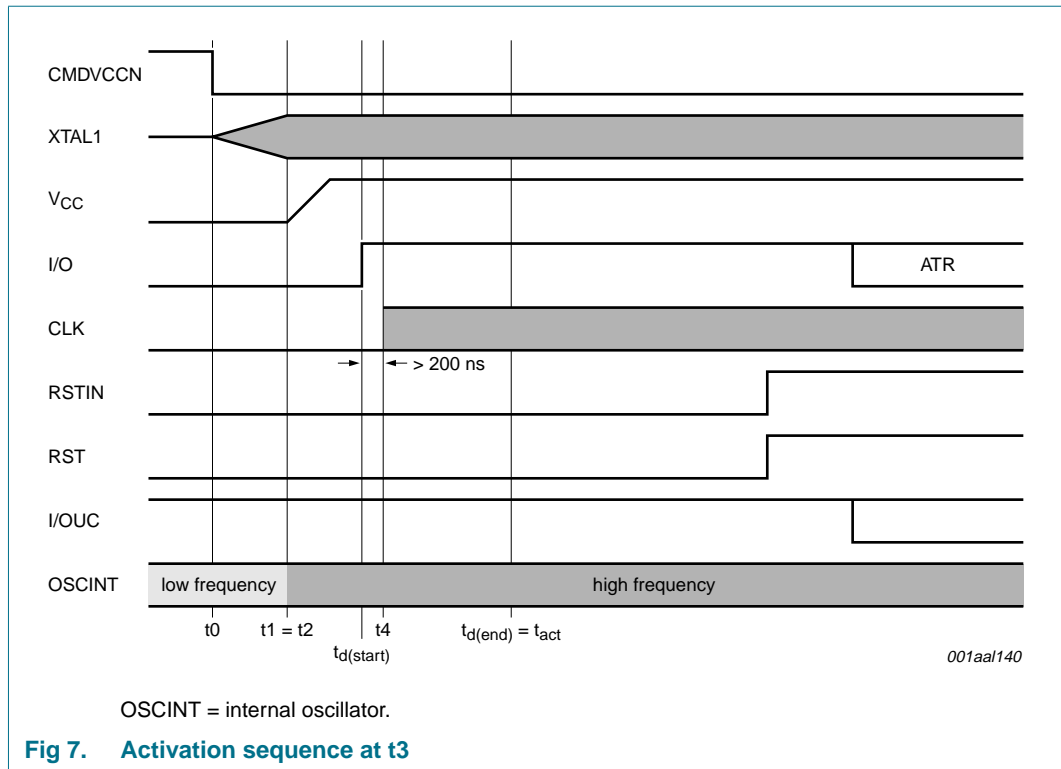

8.8 Deactivation sequence

When a session ends, the microcontroller sets pin CMDVCCN HIGH. The TDA8034HN then executes an automatic deactivation sequence by counting the sequencer back to the inactive state (see [Figure 8](#)) as follows:

1. Pin RST is pulled LOW (t11).
2. The clock is stopped, pin CLK is LOW (t12).
3. Pins I/OUC, AUX1UC and AUX2UC are pulled LOW (t13).
4. V_{CC} falls to 0 V (t14). The deactivation sequence is completed when V_{CC} reaches its inactive state.
5. V_{CC} < 0.4 V (t_{deac})
6. All card contacts become low-impedance to GND. However, pins I/OUC, AUX1UC and AUX2UC remain pulled up to V_{DD} using the 11 kΩ resistor.
7. The internal oscillator returns to its low frequency mode.

Calculation of the time delays is as follows:

- $t_{11} = t_{10} + 3T / 64$
- $t_{12} = t_{11} + T / 2$
- $t_{13} = t_{11} + T$
- $t_{14} = t_{11} + 3T / 2$
- $t_{deac} = t_{11} + 3T / 2 + V_{CC} \text{ fall time}$

Remark: The value of period T is 64 times the period interval of the internal oscillator (i.e. $\pm 25 \mu\text{s}$).

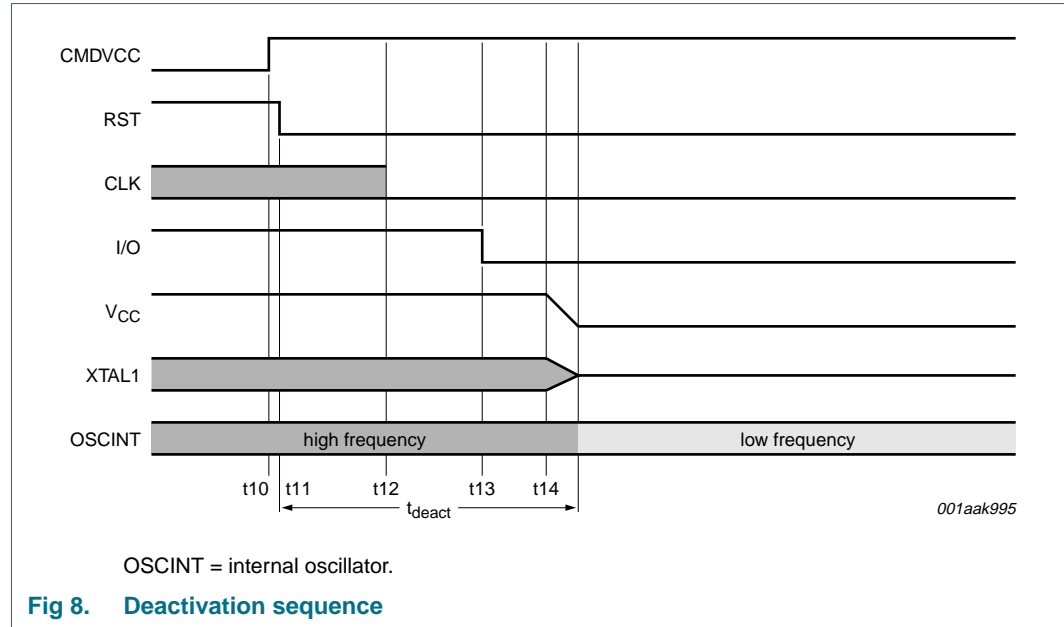

8.9 V_{CC} regulator

The V_{CC} buffer is able to continuously deliver up to 65 mA at V_{CC} = 5 V, 3 V, or 1.8 V.

The V_{CC} buffer has an internal overload protection with a threshold value of approximately 120 mA. This detection is internally filtered, enabling spurious current pulses up to 200 mA with a duration of a few milliseconds to be drawn by the card without causing deactivation. However, the average current value must stay below maximum; see [Table 8](#).

8.10 Fault detection

The following conditions are monitored by the fault detection circuit:

- Short-circuit or high current on pin V_{CC}
- Card removal during transaction
- V_{DDP} falling
- V_{DD} falling
- V_{DD(INTF)} falling
- Overheating

Fault detection monitors two different situations:

- Outside card sessions, pin CMDVCCN is HIGH: pin OFFN is LOW if the card is not in the reader and HIGH if the card is in the reader. Any voltage drop on V_{DD} is detected by the voltage supervisor. This generates an internal power-on reset pulse but does not act upon the pin OFFN signal. The card is not powered-up and short-circuits or overheating are not detected.

- In card sessions, pin CMDVCCN is LOW: when pin OFFN goes LOW, the fault detection circuit triggers the automatic emergency deactivation sequence (see [Figure 9](#)). When the microcontroller resets pin CMDVCCN to HIGH, after the deactivation sequence, pin OFFN is rechecked. If the card is still present, pin OFFN returns to HIGH. This check identifies the fault as either a hardware problem or a card removal incident.

On card insertion or removal, bouncing can occur in the PRESN signal. This depends on the type of card presence switch in the connector (normally open or normally closed) and the mechanical characteristics of the switch. To correct for this, a debouncing feature is integrated in to the TDA8034HN. This feature operates at a typical duration of 8 ms ($t_{deb} = 640 \times (1/f_{osc(int)low})$). [Figure 10 on page 13](#) shows the operation of the debouncing feature.

On card insertion, pin OFFN goes HIGH after the debounce time has elapsed. When the card is extracted, the automatic card deactivation sequence is performed on the first HIGH/LOW transition on pin PRESN. After this, pin OFFN goes LOW.

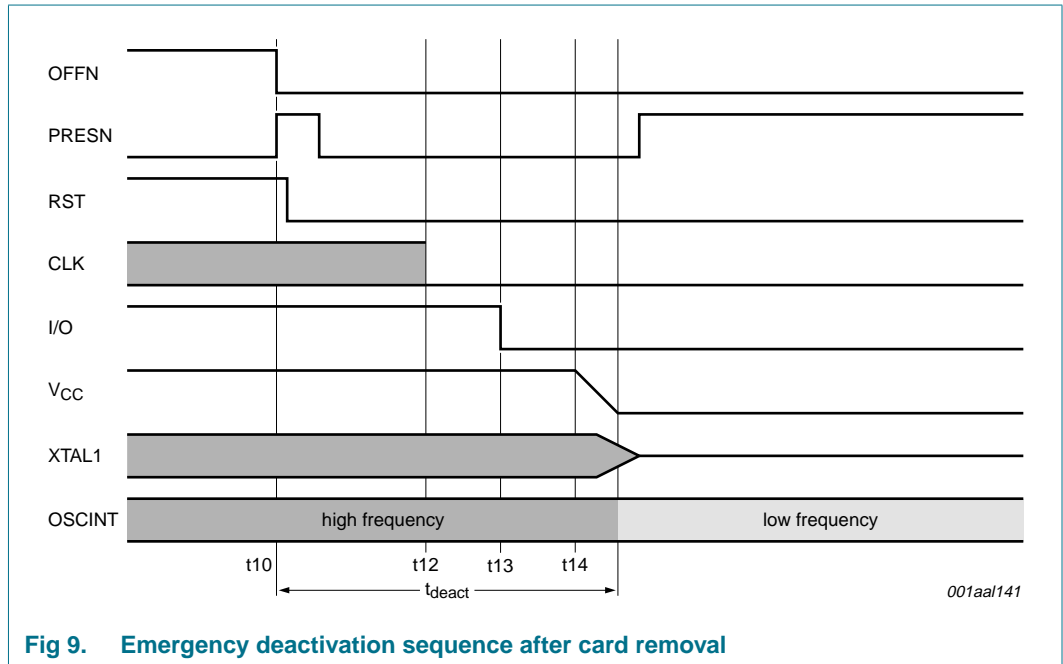

Fig 9. Emergency deactivation sequence after card removal

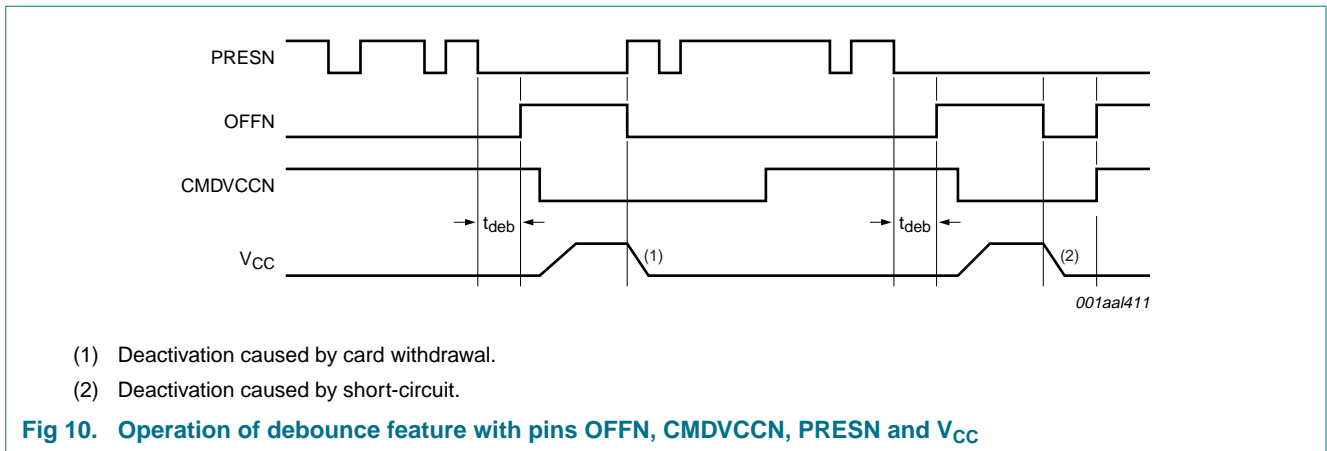

Fig 10. Operation of debounce feature with pins OFFN, CMDVCCN, PRESN and VCC

9. Limiting values

Remark: All card contacts are protected against any short-circuit to any other card contact. Stress beyond the levels indicated in [Table 5](#) can cause permanent damage to the device. This is a short-term stress rating only and under no circumstances implies functional operation under long-term stress conditions.

Table 5. Limiting values

In accordance with the Absolute Maximum Rating System (IEC 60134).

Symbol	Parameter	Conditions	Min	Max	Unit
V _{DDP}	power supply voltage	pin V _{DDP}	-0.3	+6	V
V _{DD}	supply voltage	pin V _{DD}	-0.3	+4.6	V
V _{DD(INTF)}	interface supply voltage	pin V _{DD(INTF)}	-0.3	+4.6	V
V _I	input voltage	pins CMDVCCN, CLKDIV1, CLKDIV2, VCC_SEL1, VCC_SEL2, RSTIN, OFFN, PORADJ, XTAL1, XTAL2, I/OUC, AUX1UC, AUX1UC	-0.3	+4.6	V
		card contact pins PRESN, I/O, RST, AUX1, AUX2 and CLK	-0.3	+6	V
T _{stg}	storage temperature		-55	+150	°C
P _{tot}	total power dissipation	T _{amb} = -25 °C to +85 °C	-	0.25	W
T _j	junction temperature		-	+125	°C
T _{amb}	ambient temperature		-25	+85	°C
V _{ESD}	electrostatic discharge voltage	Human Body Model (HBM) on card pins I/O, RST, V _{CC} , AUX1, AUX2, CLK, PRESN; within typical application	-6	+6	kV
		Human Body Model (HBM); all other pins	-2	+2	kV
		Machine Model (MM); all pins	-200	+200	V
		Field Charged Device Model (FCDM); all pins	-500	+500	V

10. Thermal characteristics

Table 6. Thermal characteristics

Symbol	Package name	Parameter	Conditions	Typ	Unit
$R_{th(j-a)}$	HVQFN24	thermal resistance from junction to ambient	in free air	53	K/W

11. Characteristics

Table 7. Characteristics of IC supply voltage

$V_{DDP} = 5\text{ V}$; $V_{DD} = 3.3\text{ V}$; $V_{DD(INTF)} = 3.3\text{ V}$; $f_{xtal} = 10\text{ MHz}$; $GND = 0\text{ V}$; $T_{amb} = 25\text{ °C}$; unless otherwise specified.

Symbol	Parameter	Conditions	Min	Typ	Max	Unit
Supply						
V_{DDP}	power supply voltage	pin V_{DDP}				
		$V_{CC} = 5\text{ V}$	4.85	5	5.5	V
		$V_{CC} = 3\text{ V}$ or 1.8 V	3	3.3	5.5	V
V_{DD}	supply voltage	pin V_{DD}	2.7	3.3	3.6	V
$V_{DD(INTF)}$	interface supply voltage	pin $V_{DD(INTF)}$	1.6	3.3	$V_{DD} + 0.3$	V
I_{DD}	supply current	Shutdown mode	-	-	35	μA
		Deep Shutdown mode	-	-	12	μA
I_{DDP}	power supply current	Shutdown mode				
		f_{xtal} stopped	-	-	5	μA
		Active mode				
		$f_{CLK} = \frac{1}{2} f_{xtal}$; no load	-	-	1.5	mA
		$f_{CLK} = \frac{1}{2} f_{xtal}$; $I_{CC} = 65\text{ mA}$	-	-	70	mA
$I_{DD(INTF)}$	interface supply current	Shutdown mode	-	-	6	μA
V_{th}	threshold voltage	no external resistors on pin PORADJ				
		pin V_{DD} falling	2.30	2.40	2.50	V
		pin V_{DDP} falling; $V_{CC} = 5\text{ V}$	3.00	4.10	4.40	V
		external resistors on pin PORADJ	1.20	1.24	1.29	V
V_{hys}	hysteresis voltage	no external resistors on pin PORADJ				
		pin V_{DD}	50	100	150	mV
		pin V_{DDP} ; $V_{CC} = 5\text{ V}$	100	200	350	mV
t_w	pulse width		5.1	8	10.2	ms
I_L	leakage current	pin PORADJ < 0.5 V	-0.1	+4	+10	μA
		pin PORADJ > 1 V	-1	-	+1	μA
Card supply voltage: pin V_{CC}^[1]						
C_{dec}	decoupling capacitance	connected to V_{CC}	^[2] 550	-	830	nF
V_o	output voltage	Shutdown mode				
		no load	-0.1	-	+0.1	V
		$I_o = 1\text{ mA}$	-0.1	-	+0.3	V

Table 7. Characteristics of IC supply voltage ...continued $V_{DDP} = 5\text{ V}$; $V_{DD} = 3.3\text{ V}$; $V_{DD(INTF)} = 3.3\text{ V}$; $f_{xtal} = 10\text{ MHz}$; $GND = 0\text{ V}$; $T_{amb} = 25\text{ }^\circ\text{C}$; unless otherwise specified.

Symbol	Parameter	Conditions	Min	Typ	Max	Unit	
I_o	output current	Shutdown mode; pin V_{CC} connected to ground	-	-	-1	mA	
V_{CC}	supply voltage	active mode; $I_{CC} < 65\text{ mA}$ DC					
		5 V card	4.75	5.0	5.25	V	
		3 V card	2.85	3.05	3.15	V	
		1.8 V card	1.71	1.83	1.89	V	
		active mode; current pulses of 40 nA/s at $I_{CC} < 200\text{ mA}$; $t < 400\text{ ns}$					
		5 V card	4.65	5.0	5.25	V	
$V_{ripple(p-p)}$	peak-to-peak ripple voltage	20 kHz to 200 MHz	-	-	350	mV	
		active mode; current pulses of 15 nA/s at $I_{CC} < 200\text{ mA}$; $t < 400\text{ ns}$; 1.8 V card	1.66	-	1.94	V	
		3 V card	2.76	-	3.20	V	
I_{CC}	supply current	$V_{CC} = 0\text{ V}$ to 5 V, 3 V or 1.8 V	-	-	65	mA	
		V_{CC} shorted to ground	90	120	150	mA	
SR	slew rate	5 V card	0.055	0.18	0.3	V/ μs	
		3 V card	0.040	0.18	0.3	V/ μs	
		1.8 V card	0.025	0.18	0.3	V/ μs	

Crystal oscillator: pins XTAL1 and XTAL2

C_{ext}	external capacitance	pins XTAL1 and XTAL2 (depending on the crystal or resonator specification)	-	-	15	pF
f_{xtal}	crystal frequency	card clock reference; crystal oscillator	2	-	26	MHz
f_{ext}	external frequency	external clock on pin XTAL1	0	-	26	MHz
V_{IL}	LOW-level input voltage	crystal oscillator	-0.3	-	+0.3 V_{DD}	V
		external clock	-0.3	-	+0.3 $V_{DD(INTF)}$	V
V_{IH}	HIGH-level input voltage	crystal oscillator	0.7 V_{DD}	-	$V_{DD} + 0.3$	V
		external clock	0.7 $V_{DD(INTF)}$	-	$V_{DD(INTF)} + 0.3$	V

Data lines: pins I/O, I/OUC, AUX1, AUX2, AUX1UC and AUX2UC

t_d	delay time	falling edge on pins I/O and I/OUC or vice versa	-	-	200	ns
$t_{w(pu)}$	pull-up pulse width		200	-	400	ns
f_{io}	input/output frequency	on data lines	-	-	1	MHz
C_i	input capacitance	on data lines	-	-	10	pF

Table 7. Characteristics of IC supply voltage ...continued

$V_{DDP} = 5\text{ V}$; $V_{DD} = 3.3\text{ V}$; $V_{DD(INTF)} = 3.3\text{ V}$; $f_{xtal} = 10\text{ MHz}$; $GND = 0\text{ V}$; $T_{amb} = 25\text{ °C}$; unless otherwise specified.

Symbol	Parameter	Conditions	Min	Typ	Max	Unit
Data lines to the card: pins I/O, AUX1 and AUX2^[3]						
V_o	output voltage	Shutdown mode				
		no load	0	-	0.1	V
		$I_o = 1\text{ mA}$	0	-	0.3	V
I_o	output current	Shutdown mode; pin I/O grounded	-	-	-1	mA
V_{OL}	LOW-level output voltage	$I_{OL} = 1\text{ mA}$	0	-	0.3	V
		$I_{OL} \geq 15\text{ mA}$	$V_{CC} - 0.4$	-	V_{CC}	V
V_{OH}	HIGH-level output voltage	no DC load	$0.9V_{CC}$	-	$V_{CC} + 0.1$	V
		$I_{OH} < -40\text{ }\mu\text{A}$; 5 V or 3 V	$0.75V_{CC}$	-	$V_{CC} + 0.1$	V
		$I_{OH} < -20\text{ }\mu\text{A}$; 1.8 V	$0.75V_{CC}$	-	$V_{CC} + 0.1$	V
		$I_{OH} \geq -15\text{ mA}$	0	-	0.4	V
V_{IL}	LOW-level input voltage		-0.3	-	+0.8	V
V_{IH}	HIGH-level input voltage	$V_{CC} = 5\text{ V}$	$0.6V_{CC}$	-	$V_{CC} + 0.3$	V
		$V_{CC} = 3\text{ V or }1.8\text{ V}$	$0.7V_{CC}$	-	$V_{CC} + 0.3$	V
V_{hys}	hysteresis voltage	pin I/O	-	50	-	mV
I_{IL}	LOW-level input current	pin I/O; $V_{IL} = 0\text{ V}$	-	-	600	μA
I_{IH}	HIGH-level input current	pin I/O; $V_{IH} = V_{CC}$	-	-	10	μA
$t_{r(i)}$	input rise time	V_{IL} maximum to V_{IH} minimum	-	-	1.2	μs
$t_{r(o)}$	output rise time	$C_L \leq 80\text{ pF}$; 10 % to 90 %; 0 V to V_{CC}	-	-	0.1	μs
$t_{f(i)}$	input fall time	V_{IL} maximum to V_{IH} minimum	-	-	1.2	μs
$t_{f(o)}$	output fall time	$C_L \leq 80\text{ pF}$; 10 % to 90 %; 0 V to V_{CC}	-	-	0.1	μs
R_{pu}	pull-up resistance	connected to V_{CC}	7	9	11	k Ω
I_{pu}	pull-up current	$V_{OH} = 0.9V_{CC}$; $C = 80\text{ pF}$	-8	-6	-4	mA
Data lines to the system: pins I/OUC, AUX1UC and AUX2UC^[4]						
V_{OL}	LOW-level output voltage	$I_{OL} = 1\text{ mA}$	0	-	0.3	V
V_{OH}	HIGH-level output voltage	no DC load	$0.9V_{DD(INTF)}$	-	$V_{DD(INTF)} + 0.1$	V
		$I_{OH} \leq 40\text{ }\mu\text{A}$; $V_{DD(INTF)} > 2\text{ V}$	$0.75V_{DD(INTF)}$	-	$V_{DD(INTF)} + 0.1$	V
		$I_{OH} \leq 20\text{ }\mu\text{A}$; $V_{DD(INTF)} < 2\text{ V}$	$0.75V_{DD(INTF)}$	-	$V_{DD(INTF)} + 0.1$	V
V_{IL}	LOW-level input voltage		-0.3	-	$+0.3V_{DD(INTF)}$	V
V_{IH}	HIGH-level input voltage		$0.7V_{DD(INTF)}$	-	$V_{DD(INTF)} + 0.3$	V
V_{hys}	hysteresis voltage	pin I/OUC	-	$0.14V_{DD(INTF)}$	-	V
I_{IH}	HIGH-level input current	$V_{IH} = V_{DD(INTF)}$	-	-	10	μA
I_{IL}	LOW-level input current	$V_{IL} = 0\text{ V}$	-	-	600	μA

Table 7. Characteristics of IC supply voltage ...continued

$V_{DDP} = 5\text{ V}$; $V_{DD} = 3.3\text{ V}$; $V_{DD(INTF)} = 3.3\text{ V}$; $f_{xtal} = 10\text{ MHz}$; $GND = 0\text{ V}$; $T_{amb} = 25\text{ °C}$; unless otherwise specified.

Symbol	Parameter	Conditions	Min	Typ	Max	Unit
R_{pu}	pull-up resistance	connected to $V_{DD(INTF)}$	8	10	12	$k\Omega$
$t_{r(i)}$	input rise time	V_{IL} maximum to V_{IH} minimum	-	-	1.2	μs
$t_{r(o)}$	output rise time	$C_L \leq 30\text{ pF}$; 10 % to 90 %; 0 V to $V_{DD(INTF)}$	-	-	0.1	μs
$t_{f(i)}$	input fall time	V_{IL} maximum to V_{IH} minimum	-	-	1.2	μs
$t_{f(o)}$	output fall time	$C_L \leq 30\text{ pF}$; 10 % to 90 %; 0 V to $V_{DD(INTF)}$	-	-	0.1	μs
I_{pu}	pull-up current	$V_{OH} = 0.9V_{DD}$; $C = 30\text{ pF}$	-1	-	-	mA

Internal oscillator

$f_{osc(int)}$	internal oscillator frequency	Shutdown mode	100	150	200	kHz
		active state	2	2.7	3.2	MHz

Reset output to the card: pin RST

V_o	output voltage	Shutdown mode				
		no load	0	-	0.1	V
		$I_o = 1\text{ mA}$	0	-	0.3	V
I_o	output current	Shutdown mode; pin RST grounded	-	-	-1	mA
t_d	delay time	between pins RSTIN and RST; RST enabled	-	-	2	μs
V_{OL}	LOW-level output voltage	$I_{OL} = 200\text{ }\mu\text{A}$; $V_{CC} = 5\text{ V}$	0	-	0.3	V
		$I_{OL} = 200\text{ }\mu\text{A}$; $V_{CC} = 3\text{ V}$ or 1.8 V	0	-	0.2	V
		current limit $I_{OL} = 20\text{ mA}$	$V_{CC} - 0.4$	-	V_{CC}	V
V_{OH}	HIGH-level output voltage	$I_{OH} = -200\text{ }\mu\text{A}$	$0.9V_{CC}$	-	V_{CC}	V
		current limit $I_{OH} = -20\text{ mA}$	0	-	0.4	V
t_r	rise time	$C_L = 100\text{ pF}$	-	-	0.1	μs
t_f	fall time	$C_L = 100\text{ pF}$	-	-	0.1	μs

Clock output to the card: pin CLK

V_o	output voltage	Shutdown mode				
		no load	0	-	0.1	V
		$I_o = 1\text{ mA}$	0	-	0.3	V
I_o	output current	Shutdown mode; pin CLK grounded	-	-	-1	mA
V_{OL}	LOW-level output voltage	$I_{OL} = 200\text{ }\mu\text{A}$	0	-	0.3	V
		current limit $I_{OL} = 70\text{ mA}$	$V_{CC} - 0.4$	-	V_{CC}	V
V_{OH}	HIGH-level output voltage	$I_{OH} = -200\text{ }\mu\text{A}$	$0.9V_{CC}$	-	V_{CC}	V
		current limit $I_{OH} = -70\text{ mA}$	0	-	0.4	V
t_r	rise time	$C_L = 30\text{ pF}$	[5] -	-	16	ns
t_f	fall time	$C_L = 30\text{ pF}$	[5] -	-	16	ns
f_{CLK}	frequency on pin CLK	operational	0	-	20	MHz

Table 7. Characteristics of IC supply voltage ...continued

$V_{DDP} = 5\text{ V}$; $V_{DD} = 3.3\text{ V}$; $V_{DD(INTF)} = 3.3\text{ V}$; $f_{xtal} = 10\text{ MHz}$; $GND = 0\text{ V}$; $T_{amb} = 25\text{ °C}$; unless otherwise specified.

Symbol	Parameter	Conditions	Min	Typ	Max	Unit
δ	duty cycle	$C_L = 30\text{ pF}$	[5] 45	-	55	%
SR	slew rate	rise and fall; $C_L = 30\text{ pF}$				
		$V_{CC} = 5\text{ V}$	0.2	-	-	V/ns
		$V_{CC} = 3\text{ V or }1.8\text{ V}$	0.12	-	-	V/ns

Control inputs: pins CLKDIV1, CLKDIV2, RSTIN, VCC_SEL1 and VCC_SEL2[6]

V_{IL}	LOW-level input voltage		-0.3	-	$0.3V_{DD(INTF)}$	V
V_{IH}	HIGH-level input voltage		$0.7V_{DD(INTF)}$	-	$V_{DD(INTF)} + 0.3$	V
V_{hys}	hysteresis voltage	control input	-	$0.14V_{DD(INTF)}$	-	V
I_{IL}	LOW-level input current	$V_{IL} = 0\text{ V}$	-	-	1	μA
I_{IH}	HIGH-level input current	$V_{IH} = V_{DD(INTF)}$	-	-	1	μA

Control input: pin CMDVCCN[6]

V_{IL}	LOW-level input voltage		-0.3	-	$0.3V_{DD(INTF)}$	V
V_{IH}	HIGH-level input voltage		$0.7V_{DD(INTF)}$	-	$V_{DD(INTF)} + 0.3$	V
V_{hys}	hysteresis voltage	control input	-	$0.14V_{DD(INTF)}$	-	V
I_{IL}	LOW-level input current	$V_{IL} = 0\text{ V}$	-	-	1	μA
I_{IH}	HIGH-level input current	$V_{IH} = V_{DD(INTF)}$	-	-	1	μA
$f_{CMDVCCN}$	frequency on pin CMDVCCN		-	-	100	Hz
t_w	pulse width	5 V card	30	-	-	ms
		3 V card	-	-	15	ms

Card detection input: pin PRESN[6][7]

V_{IL}	LOW-level input voltage		-0.3	-	$0.3V_{DD(INTF)}$	V
V_{IH}	HIGH-level input voltage		$0.7V_{DD(INTF)}$	-	$V_{DD(INTF)} + 0.3$	V
V_{hys}	hysteresis voltage	pin PRESN	-	$0.14V_{DD(INTF)}$	-	V
I_{IL}	LOW-level input current	$0\text{ V} < V_{IL} < V_{DD(INTF)}$	-	-	5	μA
I_{IH}	HIGH-level input current	$0\text{ V} < V_{IH} < V_{DD(INTF)}$	-	-	5	μA

OFFN output[8]

V_{OL}	LOW-level output voltage	$I_{OL} = 2\text{ mA}$	0	-	0.3	V
V_{OH}	HIGH-level output voltage	$I_{OH} = -15\text{ }\mu\text{A}$	$0.75V_{DD(INTF)}$	-	-	V
R_{pu}	pull-up resistance	connected to $V_{DD(INTF)}$	16	20	24	k Ω

[1] To meet these specifications, V_{CC} should be decoupled to pin GND using two ceramic multilayer capacitors of low ESR with values of one 220 nF and one 470 nF.

[2] Using decoupling capacitors of one 220 nF $\pm 20\%$ and one 470 nF $\pm 20\%$.

[3] Using the integrated 9 k Ω pull-up resistor connected to V_{CC} .

[4] Using the integrated 10 k Ω pull-up resistor connected to $V_{DD(INTF)}$.

- [5] The transition time and the duty factor definitions are shown in [Figure 11 on page 19](#); $\delta = t1 / (t1 + t2)$.
- [6] Pins PRESN and CMDVCCN are active LOW; pin RSTIN is active HIGH; see [Table 4](#) for states of pins CLKDIV1 and CLKDIV2.
- [7] Pin PRESN has an integrated current source of 1.25 μ A to $V_{DD(INTF)}$.
- [8] Pin OFFN is an NMOS drain, using an internal 20 k Ω pull-up resistor connected to $V_{DD(INTF)}$.

Table 8. Protection characteristics

Symbol	Parameter	Conditions	Min	Typ	Max	Unit
I_{Olim}	output current limit	pin I/O	-15	-	+15	mA
		pin V_{CC}	135	175	225	mA
		pin CLK	-70	-	+70	mA
		pin RST	-20	-	+20	mA
I_{sd}	shutdown current	pin V_{CC}	90	120	150	mA
T_{sd}	shutdown temperature	at die	-	150	-	$^{\circ}$ C

Table 9. Timing characteristics

Symbol	Parameter	Conditions	Min	Typ	Max	Unit
t_{act}	activation time	see Figure 7 on page 10	2090	-	4160	μ s
t_{deact}	deactivation time	see Figure 8 on page 11	35	90	250	μ s
t_d	delay time	CLK sent to card using an external clock				
		$t_{d(start)} = t3$; see Figure 7 on page 10	2090	-	4112	μ s
		$t_{d(end)} = t5$; see Figure 7 on page 10	2120	-	4160	μ s
t_{deb}	debounce time	pin PRESN	3.2	4.5	6.4	ms

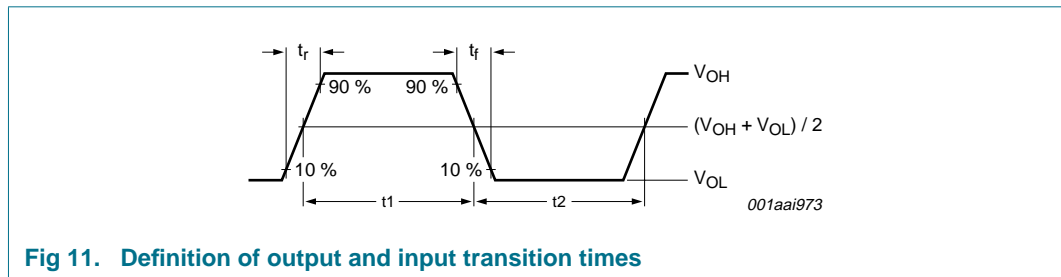

12. Application information

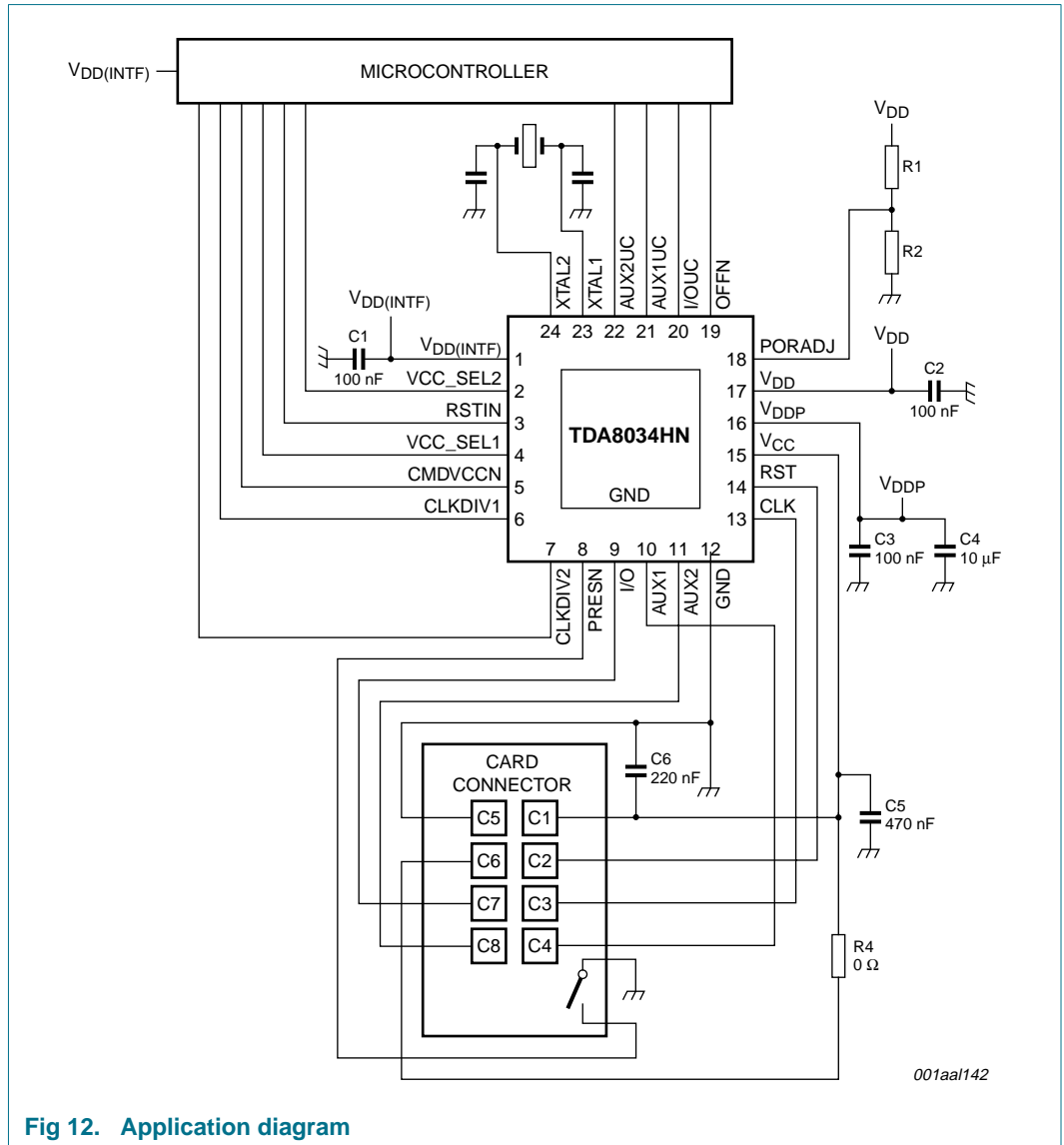
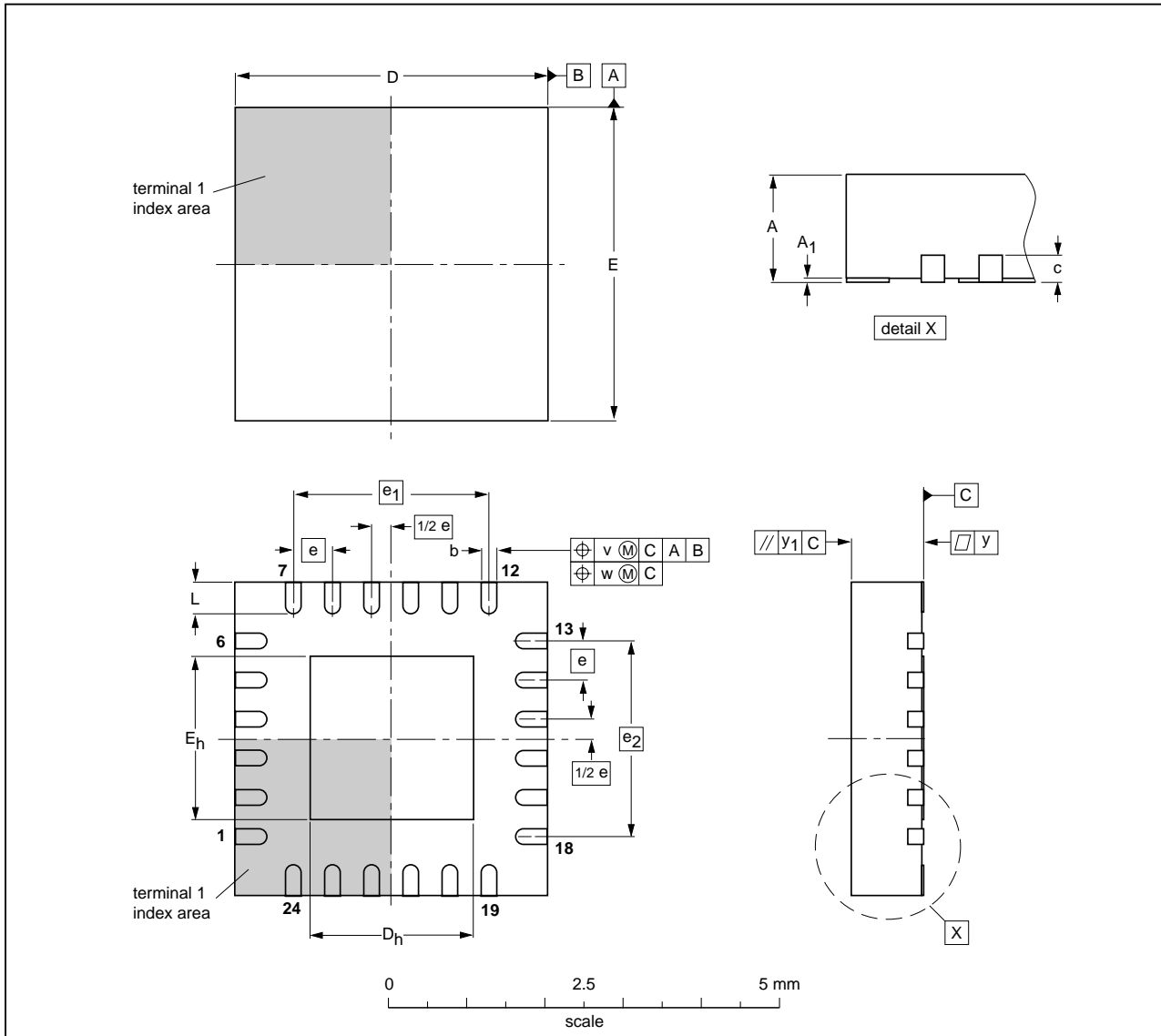

Fig 12. Application diagram

13. Package outline

HVQFN24: plastic thermal enhanced very thin quad flat package; no leads; 24 terminals; body 4 x 4 x 0.85 mm

SOT616-1



DIMENSIONS (mm are the original dimensions)

UNIT	A ⁽¹⁾ max.	A ₁	b	c	D ⁽¹⁾	D _h	E ⁽¹⁾	E _h	e	e ₁	e ₂	L	v	w	y	y ₁
mm	1	0.05 0.00	0.30 0.18	0.2	4.1 3.9	2.25 1.95	4.1 3.9	2.25 1.95	0.5	2.5	2.5	0.5 0.3	0.1	0.05	0.05	0.1

Note

1. Plastic or metal protrusions of 0.075 mm maximum per side are not included.

OUTLINE VERSION	REFERENCES				EUROPEAN PROJECTION	ISSUE DATE
	IEC	JEDEC	JEITA			
SOT616-1	---	MO-220	---			01-08-08- 02-10-22

Fig 13. Package outline SOT616-1 (HVQFN24)

14. Soldering of SMD packages

This text provides a very brief insight into a complex technology. A more in-depth account of soldering ICs can be found in Application Note *AN10365 "Surface mount reflow soldering description"*.

14.1 Introduction to soldering

Soldering is one of the most common methods through which packages are attached to Printed Circuit Boards (PCBs), to form electrical circuits. The soldered joint provides both the mechanical and the electrical connection. There is no single soldering method that is ideal for all IC packages. Wave soldering is often preferred when through-hole and Surface Mount Devices (SMDs) are mixed on one printed wiring board; however, it is not suitable for fine pitch SMDs. Reflow soldering is ideal for the small pitches and high densities that come with increased miniaturization.

14.2 Wave and reflow soldering

Wave soldering is a joining technology in which the joints are made by solder coming from a standing wave of liquid solder. The wave soldering process is suitable for the following:

- Through-hole components
- Leaded or leadless SMDs, which are glued to the surface of the printed circuit board

Not all SMDs can be wave soldered. Packages with solder balls, and some leadless packages which have solder lands underneath the body, cannot be wave soldered. Also, leaded SMDs with leads having a pitch smaller than ~0.6 mm cannot be wave soldered, due to an increased probability of bridging.

The reflow soldering process involves applying solder paste to a board, followed by component placement and exposure to a temperature profile. Leaded packages, packages with solder balls, and leadless packages are all reflow solderable.

Key characteristics in both wave and reflow soldering are:

- Board specifications, including the board finish, solder masks and vias
- Package footprints, including solder thieves and orientation
- The moisture sensitivity level of the packages
- Package placement
- Inspection and repair
- Lead-free soldering versus SnPb soldering

14.3 Wave soldering

Key characteristics in wave soldering are:

- Process issues, such as application of adhesive and flux, clinching of leads, board transport, the solder wave parameters, and the time during which components are exposed to the wave
- Solder bath specifications, including temperature and impurities

14.4 Reflow soldering

Key characteristics in reflow soldering are:

- Lead-free versus SnPb soldering; note that a lead-free reflow process usually leads to higher minimum peak temperatures (see [Figure 14](#)) than a SnPb process, thus reducing the process window
- Solder paste printing issues including smearing, release, and adjusting the process window for a mix of large and small components on one board
- Reflow temperature profile; this profile includes preheat, reflow (in which the board is heated to the peak temperature) and cooling down. It is imperative that the peak temperature is high enough for the solder to make reliable solder joints (a solder paste characteristic). In addition, the peak temperature must be low enough that the packages and/or boards are not damaged. The peak temperature of the package depends on package thickness and volume and is classified in accordance with [Table 10](#) and [11](#)

Table 10. SnPb eutectic process (from J-STD-020C)

Package thickness (mm)	Package reflow temperature (°C)	
	Volume (mm ³)	
	< 350	≥ 350
< 2.5	235	220
≥ 2.5	220	220

Table 11. Lead-free process (from J-STD-020C)

Package thickness (mm)	Package reflow temperature (°C)		
	Volume (mm ³)		
	< 350	350 to 2000	> 2000
< 1.6	260	260	260
1.6 to 2.5	260	250	245
> 2.5	250	245	245

Moisture sensitivity precautions, as indicated on the packing, must be respected at all times.

Studies have shown that small packages reach higher temperatures during reflow soldering, see [Figure 14](#).

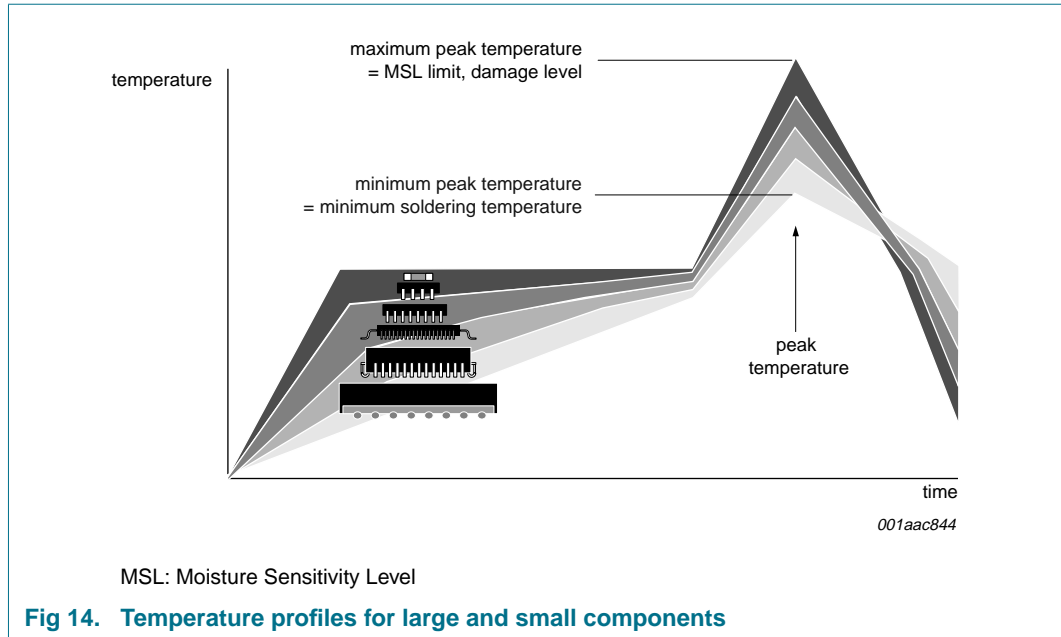

For further information on temperature profiles, refer to Application Note AN10365 “Surface mount reflow soldering description”.

15. Abbreviations

Table 12. Abbreviations

Acronym	Description
EMV	Europay MasterCard VISA
ESD	ElectroStatic Discharge
ESR	Equivalent Series Resistor
FCDM	Field Charged Device Model
HBM	Human Body Model
LDO	Low Drop-Out
MM	Machine Model
NMOS	Negative-channel Metal-Oxide Semiconductor
POR	Power-On Reset

16. Revision history

Table 13. Revision history

Document ID	Release date	Data sheet status	Change notice	Supersedes
TDA8034HN_1	20100205	Product data sheet	-	-

17. Legal information

17.1 Data sheet status

Document status ^{[1][2]}	Product status ^[3]	Definition
Objective [short] data sheet	Development	This document contains data from the objective specification for product development.
Preliminary [short] data sheet	Qualification	This document contains data from the preliminary specification.
Product [short] data sheet	Production	This document contains the product specification.

[1] Please consult the most recently issued document before initiating or completing a design.

[2] The term 'short data sheet' is explained in section "Definitions".

[3] The product status of device(s) described in this document may have changed since this document was published and may differ in case of multiple devices. The latest product status information is available on the Internet at URL <http://www.nxp.com>.

17.2 Definitions

Draft — The document is a draft version only. The content is still under internal review and subject to formal approval, which may result in modifications or additions. NXP Semiconductors does not give any representations or warranties as to the accuracy or completeness of information included herein and shall have no liability for the consequences of use of such information.

Short data sheet — A short data sheet is an extract from a full data sheet with the same product type number(s) and title. A short data sheet is intended for quick reference only and should not be relied upon to contain detailed and full information. For detailed and full information see the relevant full data sheet, which is available on request via the local NXP Semiconductors sales office. In case of any inconsistency or conflict with the short data sheet, the full data sheet shall prevail.

Product specification — The information and data provided in a Product data sheet shall define the specification of the product as agreed between NXP Semiconductors and its customer, unless NXP Semiconductors and customer have explicitly agreed otherwise in writing. In no event however, shall an agreement be valid in which the NXP Semiconductors product is deemed to offer functions and qualities beyond those described in the Product data sheet.

17.3 Disclaimers

Limited warranty and liability — Information in this document is believed to be accurate and reliable. However, NXP Semiconductors does not give any representations or warranties, expressed or implied, as to the accuracy or completeness of such information and shall have no liability for the consequences of use of such information.

In no event shall NXP Semiconductors be liable for any indirect, incidental, punitive, special or consequential damages (including - without limitation - lost profits, lost savings, business interruption, costs related to the removal or replacement of any products or rework charges) whether or not such damages are based on tort (including negligence), warranty, breach of contract or any other legal theory.

Notwithstanding any damages that customer might incur for any reason whatsoever, NXP Semiconductors' aggregate and cumulative liability towards customer for the products described herein shall be limited in accordance with the *Terms and conditions of commercial sale* of NXP Semiconductors.

Right to make changes — NXP Semiconductors reserves the right to make changes to information published in this document, including without limitation specifications and product descriptions, at any time and without notice. This document supersedes and replaces all information supplied prior to the publication hereof.

Suitability for use — NXP Semiconductors products are not designed, authorized or warranted to be suitable for use in medical, military, aircraft, space or life support equipment, nor in applications where failure or

malfunction of an NXP Semiconductors product can reasonably be expected to result in personal injury, death or severe property or environmental damage. NXP Semiconductors accepts no liability for inclusion and/or use of NXP Semiconductors products in such equipment or applications and therefore such inclusion and/or use is at the customer's own risk.

Applications — Applications that are described herein for any of these products are for illustrative purposes only. NXP Semiconductors makes no representation or warranty that such applications will be suitable for the specified use without further testing or modification.

NXP Semiconductors does not accept any liability related to any default, damage, costs or problem which is based on a weakness or default in the customer application/use or the application/use of customer's third party customer(s) (hereinafter both referred to as "Application"). It is customer's sole responsibility to check whether the NXP Semiconductors product is suitable and fit for the Application planned. Customer has to do all necessary testing for the Application in order to avoid a default of the Application and the product. NXP Semiconductors does not accept any liability in this respect.

Limiting values — Stress above one or more limiting values (as defined in the Absolute Maximum Ratings System of IEC 60134) will cause permanent damage to the device. Limiting values are stress ratings only and (proper) operation of the device at these or any other conditions above those given in the Recommended operating conditions section (if present) or the Characteristics sections of this document is not warranted. Constant or repeated exposure to limiting values will permanently and irreversibly affect the quality and reliability of the device.

Terms and conditions of commercial sale — NXP Semiconductors products are sold subject to the general terms and conditions of commercial sale, as published at <http://www.nxp.com/profile/terms>, unless otherwise agreed in a valid written individual agreement. In case an individual agreement is concluded only the terms and conditions of the respective agreement shall apply. NXP Semiconductors hereby expressly objects to applying the customer's general terms and conditions with regard to the purchase of NXP Semiconductors products by customer.

No offer to sell or license — Nothing in this document may be interpreted or construed as an offer to sell products that is open for acceptance or the grant, conveyance or implication of any license under any copyrights, patents or other industrial or intellectual property rights.

Export control — This document as well as the item(s) described herein may be subject to export control regulations. Export might require a prior authorization from national authorities.

Quick reference data — The Quick reference data is an extract of the product data given in the Limiting values and Characteristics sections of this document, and as such is not complete, exhaustive or legally binding.

Non-automotive qualified products — Unless the data sheet of an NXP Semiconductors product expressly states that the product is automotive qualified, the product is not suitable for automotive use. It is neither qualified nor tested in accordance with automotive testing or application requirements. NXP Semiconductors accepts no liability for inclusion and/or use of non-automotive qualified products in automotive equipment or applications.

In the event that customer uses the product for design-in and use in automotive applications to automotive specifications and standards, customer (a) shall use the product without NXP Semiconductors' warranty of the product for such automotive applications, use and specifications, and (b) whenever customer uses the product for automotive applications beyond NXP Semiconductors' specifications such use shall be solely at customer's own risk, and (c) customer fully indemnifies NXP Semiconductors for any liability,

damages or failed product claims resulting from customer design and use of the product for automotive applications beyond NXP Semiconductors' standard warranty and NXP Semiconductors' product specifications.

17.4 Trademarks

Notice: All referenced brands, product names, service names and trademarks are the property of their respective owners.

18. Contact information

For more information, please visit: <http://www.nxp.com>

For sales office addresses, please send an email to: salesaddresses@nxp.com

19. Tables

Table 1.	Quick reference data	2
Table 2.	Ordering information	3
Table 3.	Pin description	4
Table 4.	Clock configuration	7
Table 5.	Limiting values	13
Table 6.	Thermal characteristics	14
Table 7.	Characteristics of IC supply voltage	14
Table 8.	Protection characteristics	19
Table 9.	Timing characteristics	19
Table 10.	SnPb eutectic process (from J-STD-020C)	23
Table 11.	Lead-free process (from J-STD-020C)	23
Table 12.	Abbreviations	24
Table 13.	Revision history	25

20. Figures

Fig 1. Block diagram3
 Fig 2. Pin configuration4
 Fig 3. Voltage supervisor circuit.....6
 Fig 4. Voltage supervisor waveforms.....6
 Fig 5. Basic layout for using an external clock.....7
 Fig 6. Shutdown and Deep shutdown mode
 activation/deactivation9
 Fig 7. Activation sequence at t3.....10
 Fig 8. Deactivation sequence.....11
 Fig 9. Emergency deactivation sequence after card
 removal12
 Fig 10. Operation of debounce feature with pins OFFN,
 CMDVCCN, PRESN and V_{CC}13
 Fig 11. Definition of output and input transition times ...19
 Fig 12. Application diagram20
 Fig 13. Package outline SOT616-1 (HVQFN24)21
 Fig 14. Temperature profiles for large and small
 components24

21. Contents

1	General description	1
2	Features	1
3	Applications	2
4	Quick reference data	2
5	Ordering information	3
6	Block diagram	3
7	Pinning information	4
7.1	Pinning	4
7.2	Pin description	4
8	Functional description	5
8.1	Power supplies	5
8.2	Voltage supervisor	6
8.3	Clock circuits	7
8.4	Input and output circuits	8
8.5	Shutdown mode	8
8.6	Deep shutdown mode	8
8.7	Activation sequence	9
8.8	Deactivation sequence	10
8.9	V _{CC} regulator	11
8.10	Fault detection	11
9	Limiting values	13
10	Thermal characteristics	14
11	Characteristics	14
12	Application information	20
13	Package outline	21
14	Soldering of SMD packages	22
14.1	Introduction to soldering	22
14.2	Wave and reflow soldering	22
14.3	Wave soldering	22
14.4	Reflow soldering	23
15	Abbreviations	24
16	Revision history	25
17	Legal information	26
17.1	Data sheet status	26
17.2	Definitions	26
17.3	Disclaimers	26
17.4	Trademarks	27
18	Contact information	27
19	Tables	28
20	Figures	29
21	Contents	30

Please be aware that important notices concerning this document and the product(s) described herein, have been included in section 'Legal information'.



© NXP B.V. 2010.

All rights reserved.

For more information, please visit: <http://www.nxp.com>

For sales office addresses, please send an email to: salesaddresses@nxp.com

Date of release: 5 February 2010

Document identifier: TDA8034HN_1