

**10 + 10W STEREO AMPLIFIER WITH MUTE/ST-BY**

PRODUCT PREVIEW

- WIDE SUPPLY VOLTAGE RANGE (UP TO  $\pm 22V$  ABS MAX.)
- SPLIT SUPPLY
- HIGH OUTPUT POWER:  
10 + 10W @ THD = 10%,  $R_L = 8\Omega$ ,  $V_S = \pm 14V$
- NO POP AT TURN-ON/OFF
- MUTE (POP FREE)
- STAND-BY FEATURE (LOW  $I_{Q}$ )
- FEW EXTERNAL COMPONENTS
- SHORT CIRCUIT PROTECTION
- THERMAL OVERLOAD PROTECTION

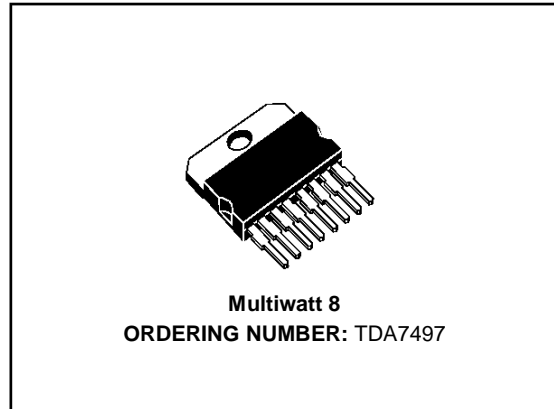

**DESCRIPTION**

The TDA7497 is class AB dual Audio power amplifier assembled in the Multiwatt package, spe-

cially designed for high quality sound application as Hi-Fi music centers and stereo TV sets.

**Figure 1:** Typical Application Circuit

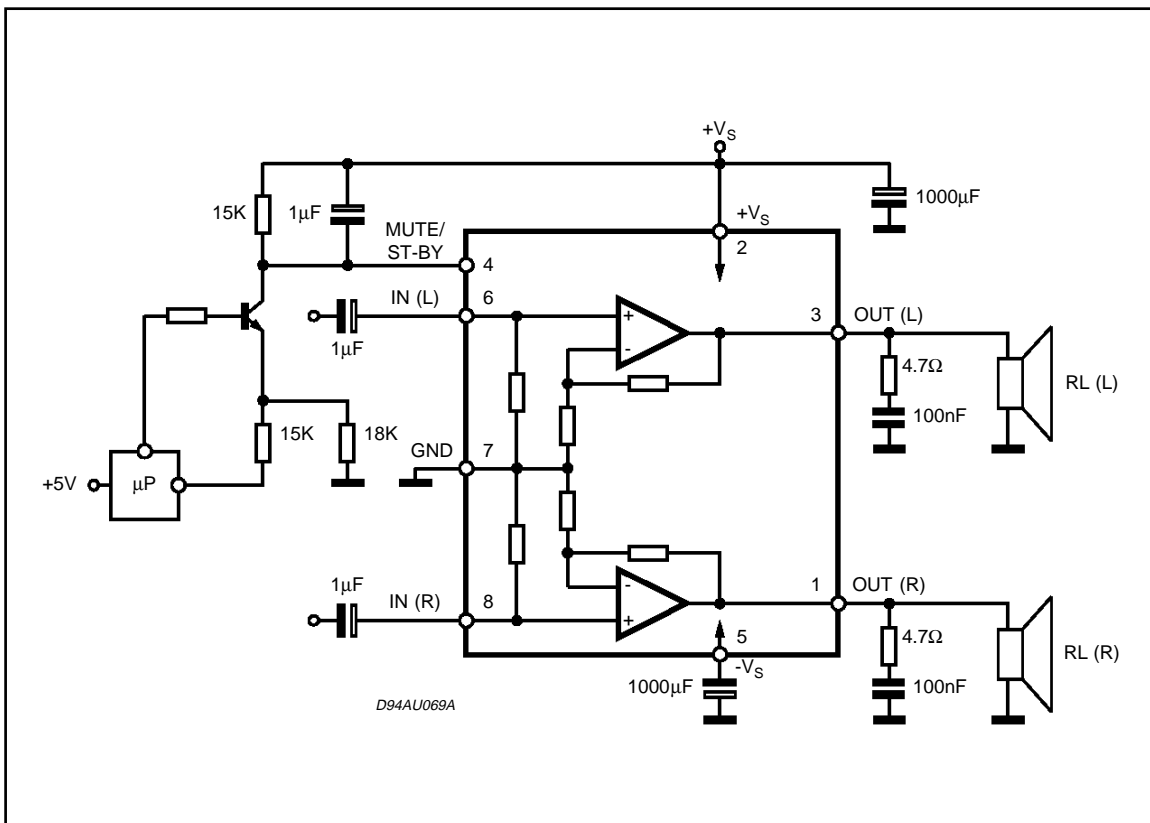

**ABSOLUTE MAXIMUM RATINGS**

Symbol	Parameter	Value	Unit
$V_S$	DC Supply Voltage	$\pm 22$	V
$I_o$	Output Peak Current (internally limited)	3	A
$P_{tot}$	Power Dissipation $T_{case} = 70^\circ\text{C}$	12	W
$T_{stg}, T_j$	Storage and Junction Temperature	-40 to +150	$^\circ\text{C}$

**PIN CONNECTION (Top view)**

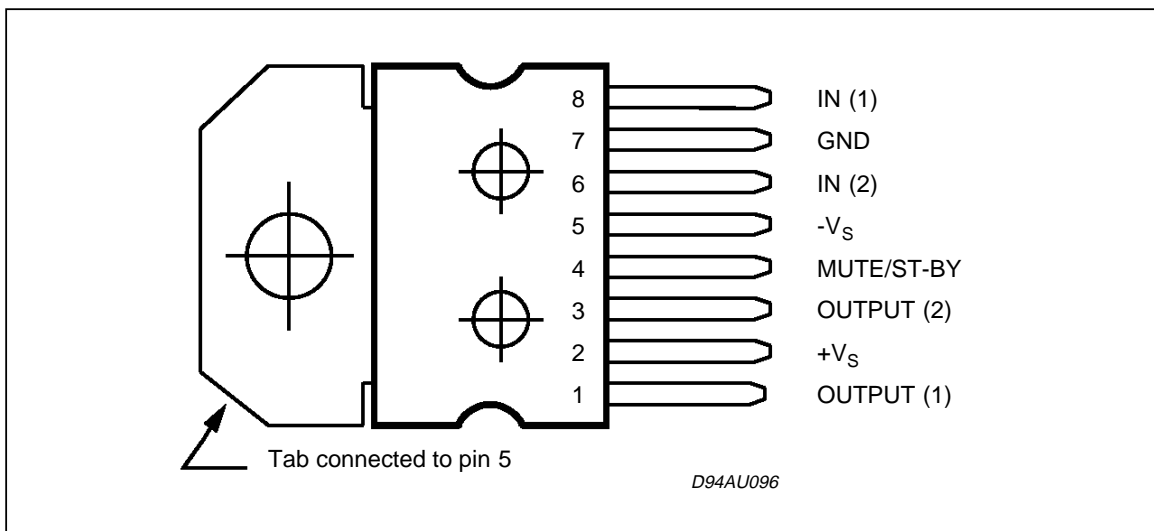

**THERMAL DATA**

Symbol	Description	Value	Unit
$R_{th\ j-case}$	Thermal Resistance Junction-case	Max 2	$^\circ\text{C/W}$

**ELECTRICAL CHARACTERISTICS** (Refer to the test circuit,  $V_S \pm 14V$ ;  $R_L = 8\Omega$ ;  $R_s = 50\Omega$ ;  $f = 1KHz$ ;  $T_{amb} = 25^\circ C$ , unless otherwise specified.)

Symbol	Parameter	Test Condition	Min.	Typ.	Max.	Unit
$V_S$	Supply Range		$\pm 5$		$\pm 20$	V
$I_q$	Total Quiescent Current			80		mA
$P_O$	Output Power	$d = 10\%$ $d = 1\%$		10 7.5		W W
$d$	Total Harmonic Distortion	$P_O = 1W$ $P_O = 0.1$ to $5W$ $f = 0.1$ to $15KHz$		0.02	0.5	% %
$C_T$	Cross Talk	$f = 1KHz$ $f = 10KHz$		70 60		dB dB
SR	Slew Rate			10		V/ $\mu s$
$G_V$	Closed Loop Voltage Gain		29	30	31	dB
$\Delta G_V$	Voltage Gain Matching			0.2		dB
$e_N$	Total Input Noise	A Curve $f = 20Hz$ to $22KHz$		2.5 3.5	8	$\mu V$ $\mu V$
$R_i$	Input Resistance		15	20		K $\Omega$
SVR	Supply Voltage Rejection (each channel)	$f_r = 100Hz$ ; $V_{ripple} = 0.5V_{RMS}$		60		dB
$T_j$	Thermal Shut-down Junction Temperature			145		$^\circ C$
<b>MUTE FUNCTION [ref: +Vs]</b>						
$V_{T_{MUTE}}$	Mute / Play Threshold		-7	-6	-5	V
$A_M$	Mute Attenuation		60	90		dB
<b>STAND-BY FUNCTION [ref: +Vs]</b>						
$V_{T_{ST-BY}}$	Stand-by / Mute Threshold		-3.5	-2.5	-1.5	V
$A_{ST-BY}$	Stand-by Attenuation			110		dB
$I_{q_{ST-BY}}$	Quiescent Current @ Stand-by			3		mA

**Note :**

(\*) **FULL POWER** up to.  $V_S = \pm 22.5V$  with  $R_L = 8\Omega$  and  $V_S = \pm 16V$  with  $R_L = 4\Omega$

**MUSIC POWER** is the maximal power which the amplifier is capable of producing across the rated load resistance (regardless of non linearity) 1 sec after the application of a sinusoidal input signal of frequency 1KHz.

**APPLICATIONS SUGGESTION**

(Demo Board Schematic)

The recommended values of the external compo-

nents are those shown on the demo board schematic. Different values can be used: the following table can help the designer.

COMPONENTS	RECOMMENDED VALUE	PURPOSE	LARGER THAN RECOMMENDED VALUE	SMALLER THAN RECOMMENDED VALUE
R1	10K $\Omega$	Mute Circuit	Increase of $I_z$ Biasing Current	
R2	15K $\Omega$	Mute Circuit	$V_{pin \# 4}$ Shifted Downward	$V_{pin \# 4}$ Shifted Upward
R3	18K $\Omega$	Mute Circuit	$V_{pin \# 4}$ Shifted Upward	$V_{pin \# 4}$ Shifted Downward
R4	15K $\Omega$	Mute Circuit	$V_{pin \# 4}$ Shifted Upward	$V_{pin \# 4}$ Shifted Downward
R5, R6	4.7 $\Omega$	Frequency Stability	Danger of Oscillations	Danger of Oscillations
C1, C2	1 $\mu F$	Input DC Decoupling		Higher Low Frequency Cutoff
C3	1 $\mu F$	St-By/Mute Time Constant	Larger On/Off Time	Smaller On/Off Time
C4, C6	1000 $\mu F$	Supply Voltage Bypass		Danger of Oscillations
C5, C7	0.1 $\mu F$	Supply Voltage Bypass		Danger of Oscillations
C8, C9	0.1 $\mu F$	Frequency Stability		
Dz	5.1V	Mute Circuit		

Figure 2: Application circuit

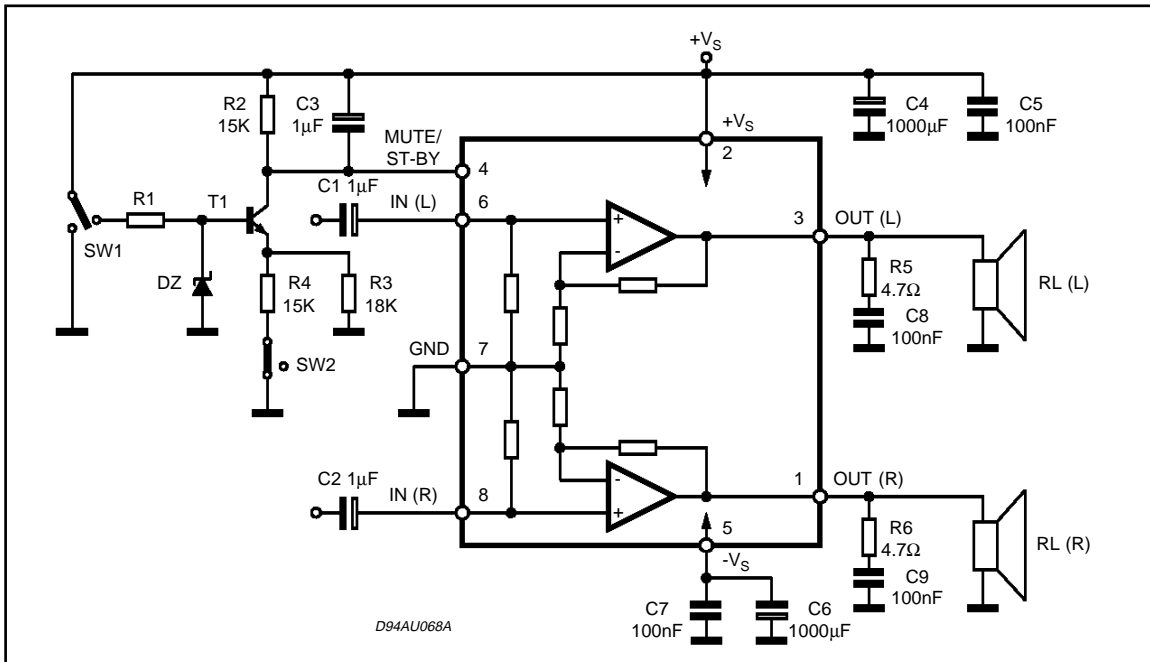
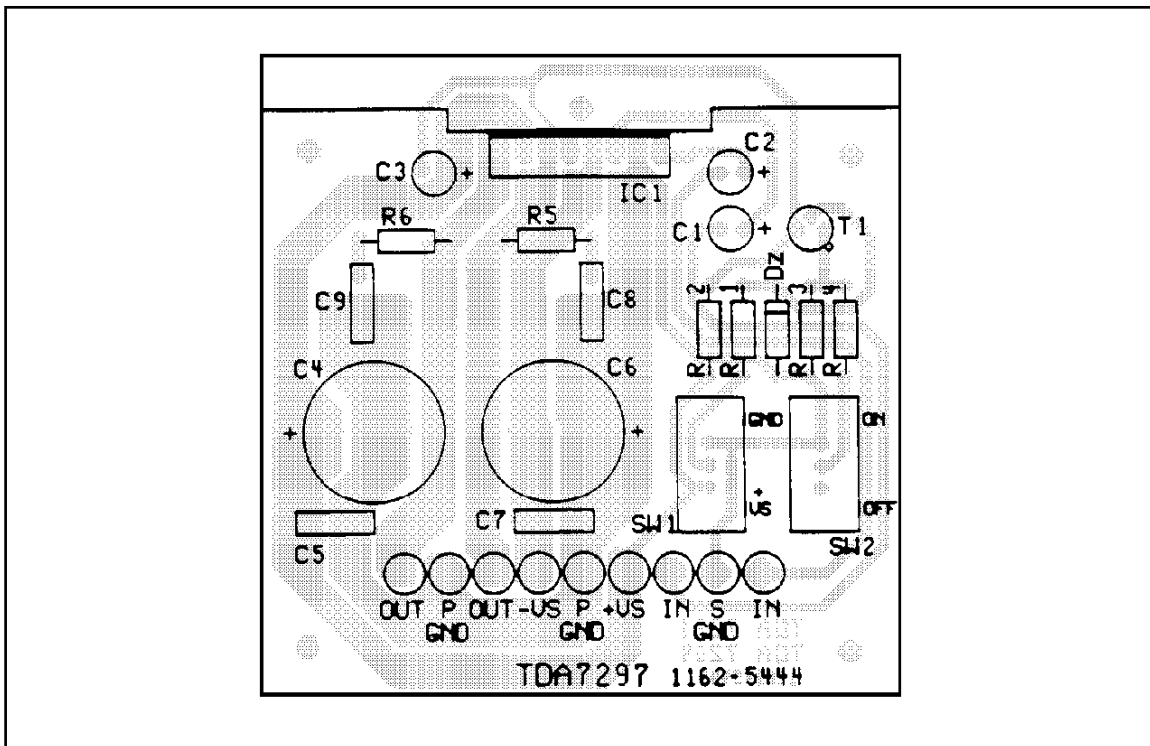

Figure 3: Demo Board Schematic



**MUTE STAND-BY FUNCTION**

The pin 4 (MUTE/STAND-BY) controls the amplifier status by two different thresholds, referred to  $+V_s$ .

- When  $V_{pin4}$  higher than  $+V_s - 2.5V$  the amplifier is in Stand-by mode and the final stage generators are off
- when  $V_{pin4}$  is between  $+V_s - 2.5V$  and  $+V_s - 6V$  the final stage current generators are switched on and the amplifier is in mute mode
- when  $V_{pin4}$  is lower than  $+V_s - 6V$  the amplifier is in play mode.

**Figure 4:** Attenuation & Total Quiescent Current vs.  $V_{pin4}$  Voltage

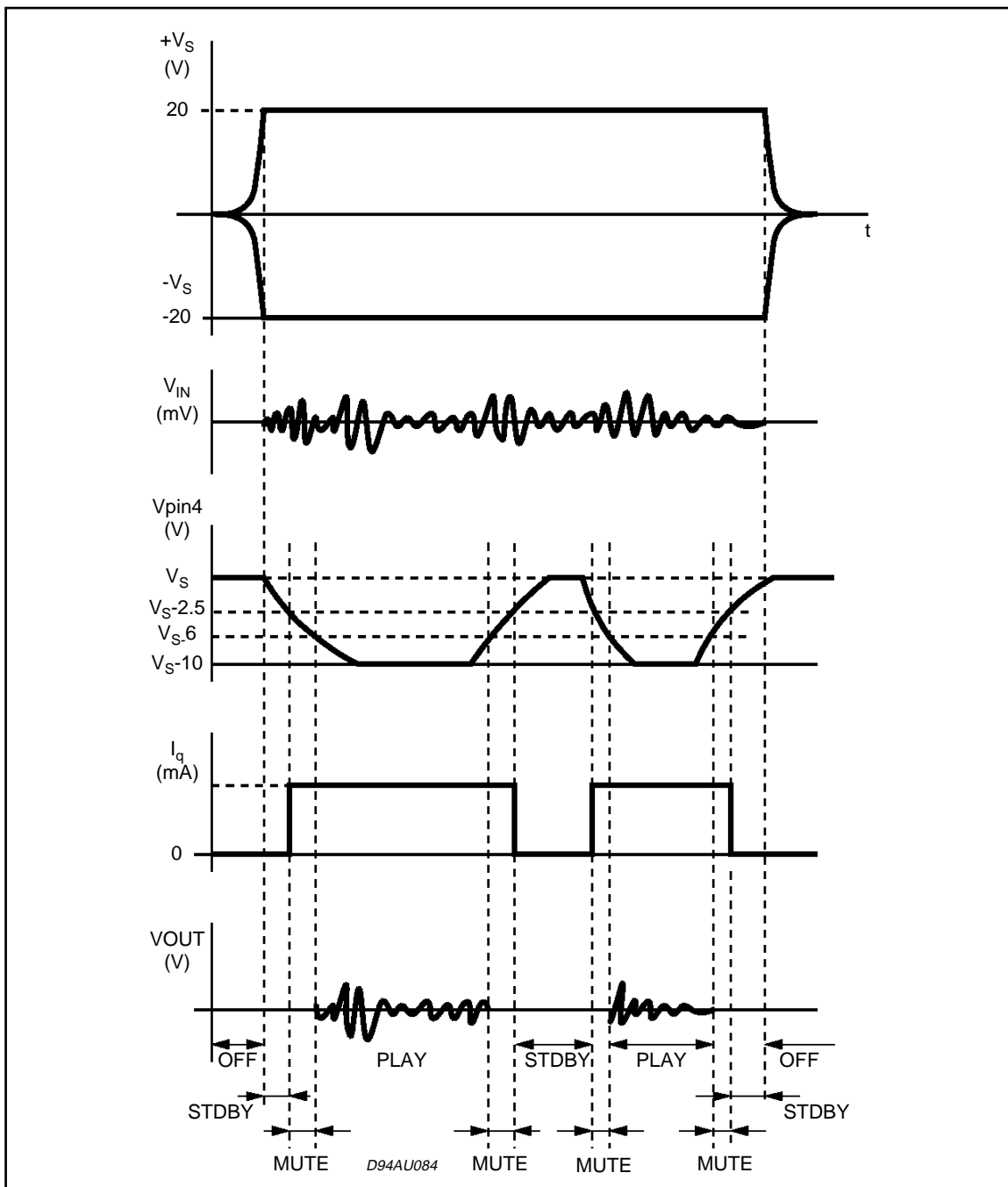

## MULTIWATT8 PACKAGE MECHANICAL DATA

DIM.	mm			inch		
	MIN.	TYP.	MAX.	MIN.	TYP.	MAX.
A			5			0.197
B			2.65			0.104
C			1.6			0.063
E	0.49		0.55	0.019		0.022
F	0.78		0.85	0.030		0.033
F1	0.68		0.75	0.027		0.029
G	2.40	2.54	2.68	0.094	0.10	0.105
G1	17.64	17.78	17.92	0.69	0.70	0.71
H1	19.6			0.772		
H2			20.2			0.795
L	20.35		20.65	0.80		0.81
L1		15.7			0.62	
L2	17.05	17.20	17.35	0.67	0.68	0.68
L3	17.25	17.5	17.75	0.679	0.689	0.699
L4	10.3	10.7	10.9	0.406	0.421	0.429
L5	15.45		15.75	0.61		0.62
L7	2.65		2.9	0.104		0.114
S	1.9		2.6	0.075		0.102
S1	1.9		2.6	0.075		0.102
U	0.40		0.55	0.015		0.022
Z	0.70		0.85	0.028		0.034
Dia1	3.65		3.85	0.144		0.152

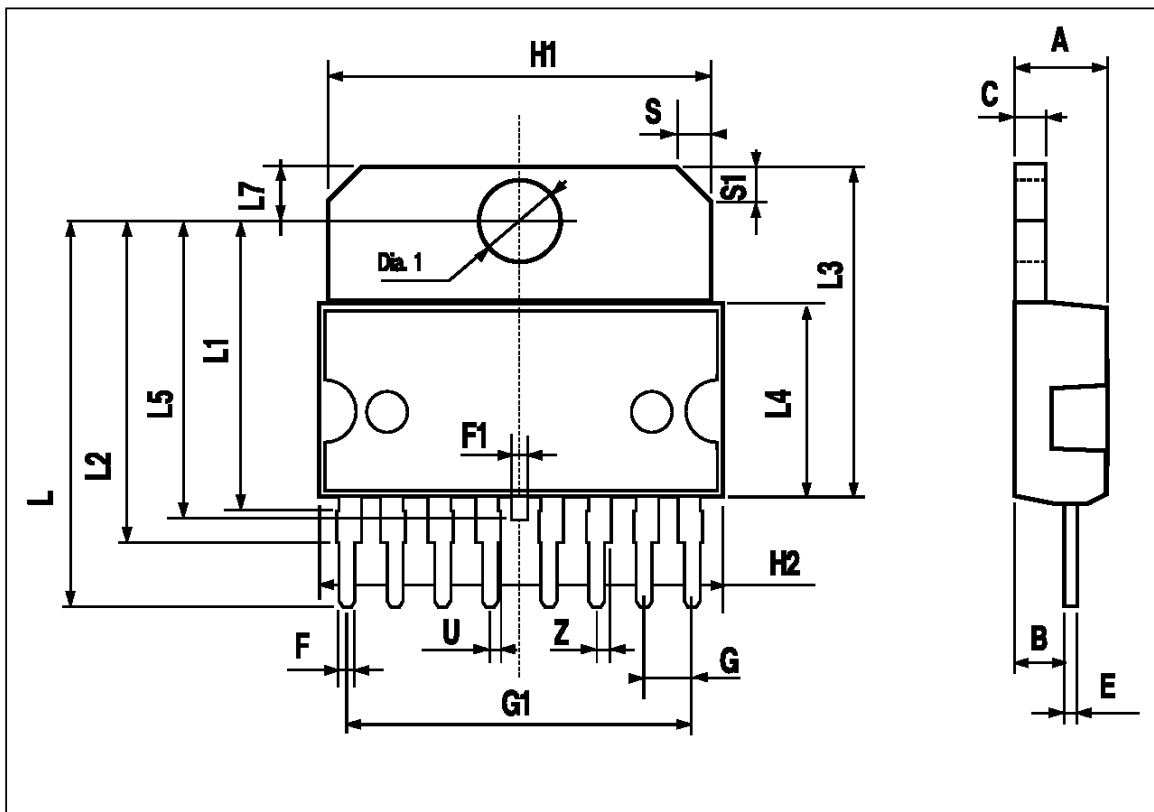

Information furnished is believed to be accurate and reliable. However, SGS-THOMSON Microelectronics assumes no responsibility for the consequences of use of such information nor for any infringement of patents or other rights of third parties which may result from its use. No license is granted by implication or otherwise under any patent or patent rights of SGS-THOMSON Microelectronics. Specifications mentioned in this publication are subject to change without notice. This publication supersedes and replaces all information previously supplied. SGS-THOMSON Microelectronics products are not authorized for use as critical components in life support devices or systems without express written approval of SGS-THOMSON Microelectronics.

© 1994 SGS-THOMSON Microelectronics - All Rights Reserved

SGS-THOMSON Microelectronics GROUP OF COMPANIES

Australia - Brazil - France - Germany - Hong Kong - Italy - Japan - Korea - Malaysia - Malta - Morocco - The Netherlands  
Singapore - Spain - Sweden - Switzerland - Taiwan - Thailand - United Kingdom - U.S.A.