

DATA SHEET

TDA4570 NTSC decoder

Product specification
File under Integrated Circuits, IC02

August 1986

NTSC decoder**TDA4570**

GENERAL DESCRIPTION

The TDA4570 is an integrated 3,58 MHz or 4,43 MHz NTSC decoder. It is pin sequence compatible with multi-standard decoder TDA4555 and pin compatible with the PAL decoder TDA4510.

Features**Chrominance part**

- Gain controlled amplifier with operating point control stage
- ACC (automatic chrominance control) with sampled rectification during burst-key signal
- Blanking circuit for the colour burst signal

Oscillator and control voltage part

- Voltage controlled reference oscillator for double subcarrier frequency
- Divider stages which provide the correct 90° phase between $-(R-Y)$ and $-(B-Y)$ reference signals for the demodulators
- Phase comparator which controls the frequency and phase of the reference oscillator and compares the $(R-Y)$ reference with the burst pulse
- HUE control stage provides phase shifting via the combined service and hue control input (pin 11)
- Identification demodulator provides a positive-going identification signal at pin 14 for NTSC signals and acts as the automatic colour killer
- Two-function service switch:
 - position one ($V_{14-3} < 1\text{ V}$): switches the colour-ON and switches the hue control and burst for the PLL oscillator-OFF, allowing the adjustment of the reference oscillator
 - position two ($V_{14-3} > 5\text{ V}$): switches the colour-ON, the hue control OFF and allows the output signal to be observed
- Sandcastle pulse detector for burst-gate, horizontal and horizontal/vertical blanking pulse detection. The vertical part of the sandcastle pulse is used for the internal colour-ON and colour-OFF delay
- Pulse processing part for the prevention of premature switching ON of the colour. The colour-ON delay, two or three field periods after identification of the NTSC signal, is achieved by a counter. When there is no identification voltage present the colour is switched OFF immediately or, at the most, one field period later.

Demodulator part

- Two synchronous demodulators for the $(R-Y)$ and $(B-Y)$ signals, which incorporate stages for the blanking during line and field flyback
- Internal filtering of the residual carrier in the demodulated colour difference signals
- Colour switching stages controlled by the pulse processing part in front of the output stages
- The output stages for $(R-Y)$ and $(B-Y)$ signals are low resistance n-p-n emitter followers
- Separate colour switching output

PACKAGE OUTLINE

16-lead DIL; plastic (SOT38); SOT38-1; 1996 November 28.

NTSC decoder

TDA4570

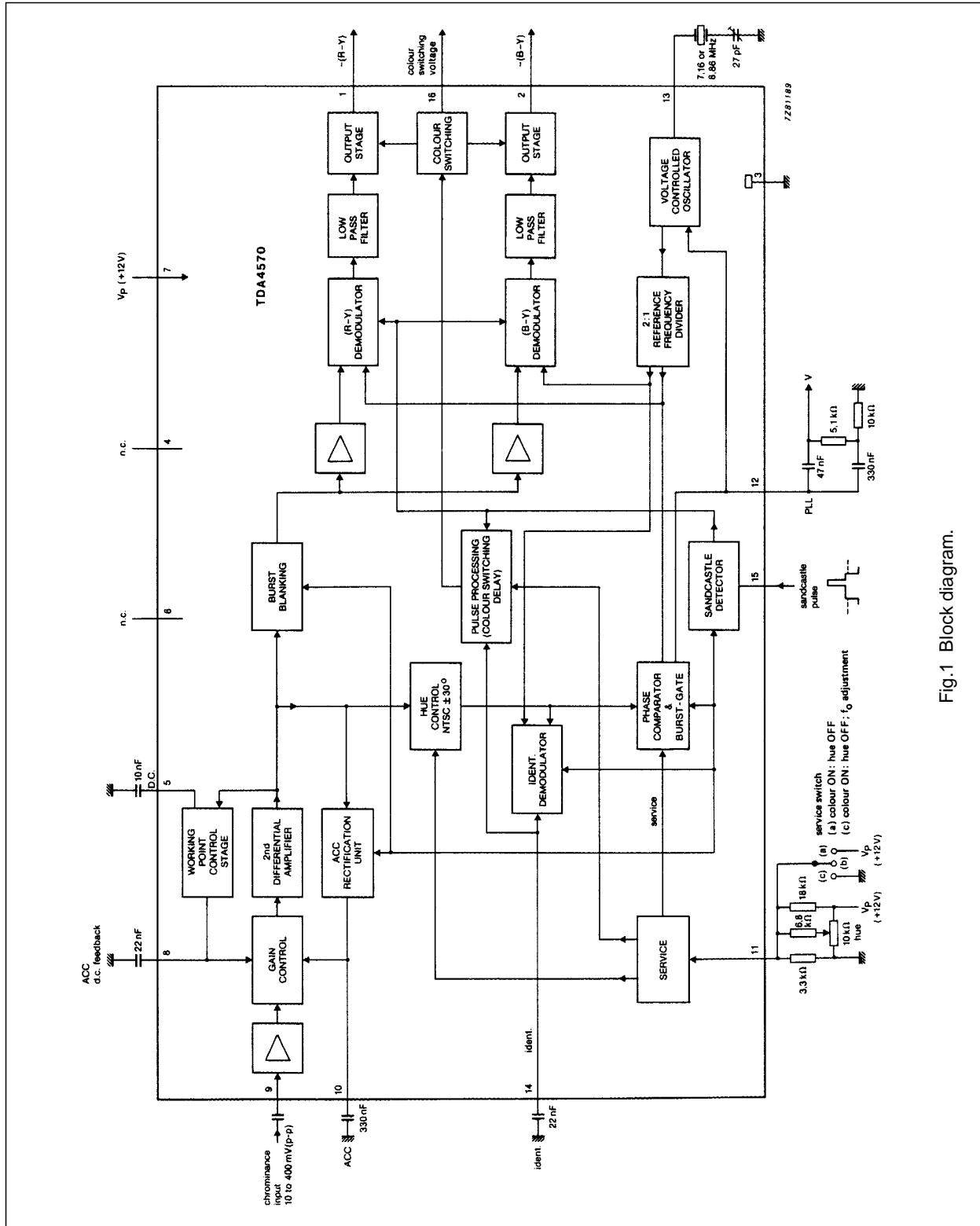

Fig.1 Block diagram.

NTSC decoder

TDA4570

RATINGS

Limiting values in accordance with the Absolute Maximum System (IEC 134)

Supply voltage range	$V_P = V_{7-3}$		10,8 to 13,2	V
Currents at:				
pins 1 and 2	$-I_{1,2}$	max.	5	mA
pin 16	$-I_{16}$	max.	5	mA
Total power dissipation	P_{tot}	max.	800	mW
Storage temperature range	T_{stg}		-25 to 150	°C
Operating ambient temperature range	T_{amb}		0 to +70	°C

THERMAL RESISTANCE

From junction to ambient in free air	$R_{th\ j-a}$	max.	80	K/W
--------------------------------------	---------------	------	----	-----

CHARACTERISTICS $V_P = 12\text{ V}$; $T_{amb} = 25\text{ °C}$; measured in Fig.2 unless otherwise specified

PARAMETER	SYMBOL	MIN.	TYP.	MAX.	UNIT
Supply current	$I_P = I_7$	–	50	–	mA
Chrominance part					
Input voltage range (peak-to-peak value)	$V_{9-3(p-p)}$	10	–	400	mV
Nominal input voltage (peak-to-peak value) with 75% colour bar signal	$V_{9-3(p-p)}$	–	100	–	mV
Input impedance	$ Z_{9-3} $	–	3,3	–	k Ω
Input capacitance	C_{9-3}	–	4,0	–	pF
Oscillator and control voltage part					
Oscillator frequency for subcarrier frequency					
3,58 MHz	f_{osc}	–	7,16	–	MHz
4,43 MHz	f_{osc}	–	8,86	–	MHz
Input resistance	R_{13-3}	–	350	–	Ω
Catching range (depending on RC network between pins 12 and 3)	Δf	± 300	–	–	Hz
Control voltage					
without burst signal	V_{14-3}	–	6,0	–	V
colour switching threshold	V_{14-3}	–	6,6	–	V
hysteresis of colour switching	V_{14-3}	–	150	–	mV
Colour-ON delay	$t_{d\ on}$	–	–	3	(note 1)
Colour-OFF delay	$t_{d\ off}$	–	–	1	(note 1)

NTSC decoder

TDA4570

PARAMETER	SYMBOL	MIN.	TYP.	MAX.	UNIT
Colour switching output (open n-p-n emitter) output current	$-I_{16}$	–	–	5, 0	mA
colour-ON voltage	V_{16-3}	–	6,0	–	V
colour-OFF voltage	V_{16-3}	–	0	–	V
HUE control and service switches					
Phase shift of reference carrier relative to the input signal $V_{11-3} = 3\text{ V}$	ϕ	–5	0	+ 5	deg
Phase shift of reference carrier relative to phase at $V_{11-3} = 3\text{ V}$ $V_{11-3} = 2\text{ V}$	$-\phi$	30	–	–	deg
$V_{11-3} = 4\text{ V}$	$+\phi$	30	–	–	deg
Internal source (open pin)		–	3	–	V
First service position (PLL is inactive for oscillator adjustment, colour ON, HUE OFF)	V_{11-3}	0	–	1	V
Second service position (colour ON, HUE OFF)	V_{11-3}	5	–	V_P	V
Demodulator part					
Colour difference signals output voltage (peak-to-peak value)					
–(R-Y) signal	$V_{1-3(p-p)}$	0,84	1,05	1,32	V
–(B-Y) signal	$V_{2-3(p-p)}$	1,06	1,33	1,67	V
Ratio of colour difference output signals (R-Y)/(B-Y)	$\frac{V_{1-3}}{V_{2-3}}$	0,71	0,79	0,87	
D.C. voltage at colour difference outputs	$V_{1,2-3}$	–	7,7	–	V
Residual carrier at colour difference outputs (peak-to-peak value)					
(1 x subcarrier frequency)	$V_{1, 2-3(p-p)}$	–	–	20	mV
(2 x subcarrier frequency)	$V_{1, 2-3(p-p)}$	–	–	30	mV

NTSC decoder

TDA4570

PARAMETER	SYMBOL	MIN.	TYP.	MAX.	UNIT
Sandcastle pulse detector (note 2)					
Input voltage level (pin 15) to separate vertical and horizontal blanking pulses	V_{15-3}	1,3	1,6	1,9	V
required pulse amplitude	V_{15-3}	2,0	2,5	3,0	V
to separate horizontal blanking pulse	V_{15-3}	3,3	3,6	3,9	V
required pulse amplitude	V_{15-3}	4,1	4,5	4,9	V
to separate burst gating pulse	V_{15-3}	6,6	7,1	7,6	V
required pulse amplitude	V_{15-3}	7,7	–	–	V
Input voltage during horizontal scanning	V_{15-3}	–	–	1,1	V
Input current	$-I_{15}$	–	–	100	μA

Notes

1. Expressed as field periods.
2. The sandcastle pulse is compared with three internal threshold levels, which are proportional to the supply voltage.

NTSC decoder

TDA4570

APPLICATION INFORMATION

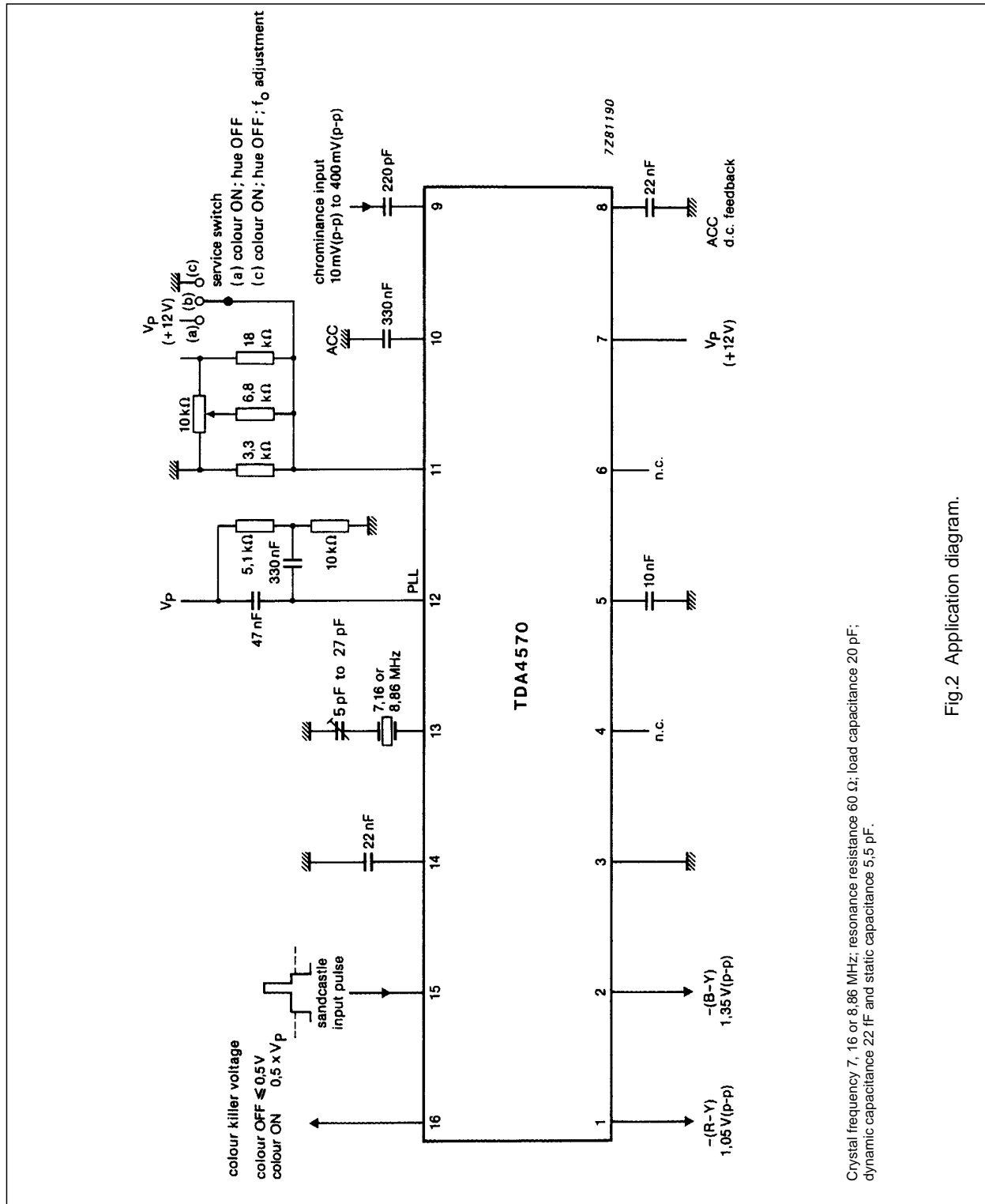

Fig.2 Application diagram.

NTSC decoder

TDA4570

PACKAGE OUTLINE

DIP16: plastic dual in-line package; 16 leads (300 mil); long body

SOT38-1

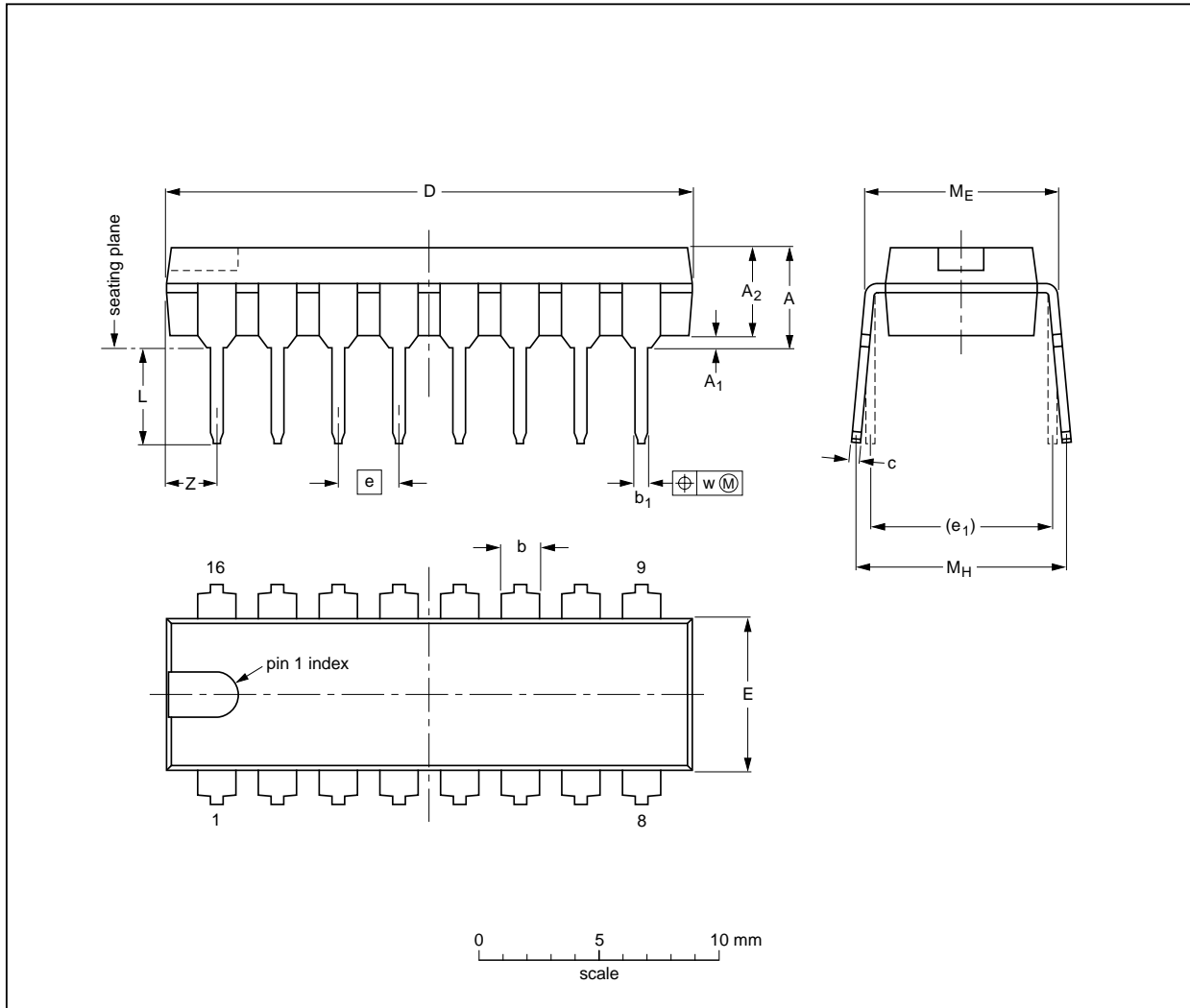

DIMENSIONS (inch dimensions are derived from the original mm dimensions)

UNIT	A max.	A ₁ min.	A ₂ max.	b	b ₁	c	D ⁽¹⁾	E ⁽¹⁾	e	e ₁	L	M _E	M _H	w	Z ⁽¹⁾ max.
mm	4.7	0.51	3.7	1.40 1.14	0.53 0.38	0.32 0.23	21.8 21.4	6.48 6.20	2.54	7.62	3.9 3.4	8.25 7.80	9.5 8.3	0.254	2.2
inches	0.19	0.020	0.15	0.055 0.045	0.021 0.015	0.013 0.009	0.86 0.84	0.26 0.24	0.10	0.30	0.15 0.13	0.32 0.31	0.37 0.33	0.01	0.087

Note

1. Plastic or metal protrusions of 0.25 mm maximum per side are not included.

OUTLINE VERSION	REFERENCES				EUROPEAN PROJECTION	ISSUE DATE
	IEC	JEDEC	EIAJ			
SOT38-1	050G09	MO-001AE				92-10-02- 95-01-19

NTSC decoder

TDA4570

SOLDERING

Introduction

There is no soldering method that is ideal for all IC packages. Wave soldering is often preferred when through-hole and surface mounted components are mixed on one printed-circuit board. However, wave soldering is not always suitable for surface mounted ICs, or for printed-circuits with high population densities. In these situations reflow soldering is often used.

This text gives a very brief insight to a complex technology. A more in-depth account of soldering ICs can be found in our "IC Package Databook" (order code 9398 652 90011).

Soldering by dipping or by wave

The maximum permissible temperature of the solder is 260 °C; solder at this temperature must not be in contact with the joint for more than 5 seconds. The total contact time of successive solder waves must not exceed 5 seconds.

The device may be mounted up to the seating plane, but the temperature of the plastic body must not exceed the specified maximum storage temperature ($T_{stg\ max}$). If the printed-circuit board has been pre-heated, forced cooling may be necessary immediately after soldering to keep the temperature within the permissible limit.

Repairing soldered joints

Apply a low voltage soldering iron (less than 24 V) to the lead(s) of the package, below the seating plane or not more than 2 mm above it. If the temperature of the soldering iron bit is less than 300 °C it may remain in contact for up to 10 seconds. If the bit temperature is between 300 and 400 °C, contact may be up to 5 seconds.

DEFINITIONS

Data sheet status	
Objective specification	This data sheet contains target or goal specifications for product development.
Preliminary specification	This data sheet contains preliminary data; supplementary data may be published later.
Product specification	This data sheet contains final product specifications.
Limiting values	
Limiting values given are in accordance with the Absolute Maximum Rating System (IEC 134). Stress above one or more of the limiting values may cause permanent damage to the device. These are stress ratings only and operation of the device at these or at any other conditions above those given in the Characteristics sections of the specification is not implied. Exposure to limiting values for extended periods may affect device reliability.	
Application information	
Where application information is given, it is advisory and does not form part of the specification.	

LIFE SUPPORT APPLICATIONS

These products are not designed for use in life support appliances, devices, or systems where malfunction of these products can reasonably be expected to result in personal injury. Philips customers using or selling these products for use in such applications do so at their own risk and agree to fully indemnify Philips for any damages resulting from such improper use or sale.