

TDA3501 Chroma Processor + RGB Drive Combination

General Description

The TDA3501 is the same basic video processor as the TDA3500 with the addition of a gated peak beam current limiter circuit. Pin 23 is used as the beam current control input and the red channel gain is biased internally to the nominal value. Drive setting is achieved using the green and blue gain adjustments only.

Application Hints

The TDA3501 is intended to be used for peak beam current limiting. Referring to the application circuit, the changing beam current waveform is developed across the resistor in series with the CRT aquadag ground return. This waveform is AC coupled to pin 23 of the TDA3501 where it is DC

restored to supply. When the negative-going peaks during the scan period pass the beam current input threshold, the contrast starts to be reduced. This action is gated off during the flyback period, blanking out flyback transients. The contrast control voltage is pulled down via an internal sink to pin 19, and the decoupling capacitor on this pin integrates the current pulses. Under extremes of beam current, the brightness will be pulled down via the internal diode connected between pins 19 and 20.

Pin 23 may also be used as an alternative blanking input, for example, for frame blanking instead of using a three-level sandcastle pulse. Negative-going blanking pulses are required and the decoupling on pin 19 should be isolated via a series resistor for reasonable rise and fall times.

Connection Diagram

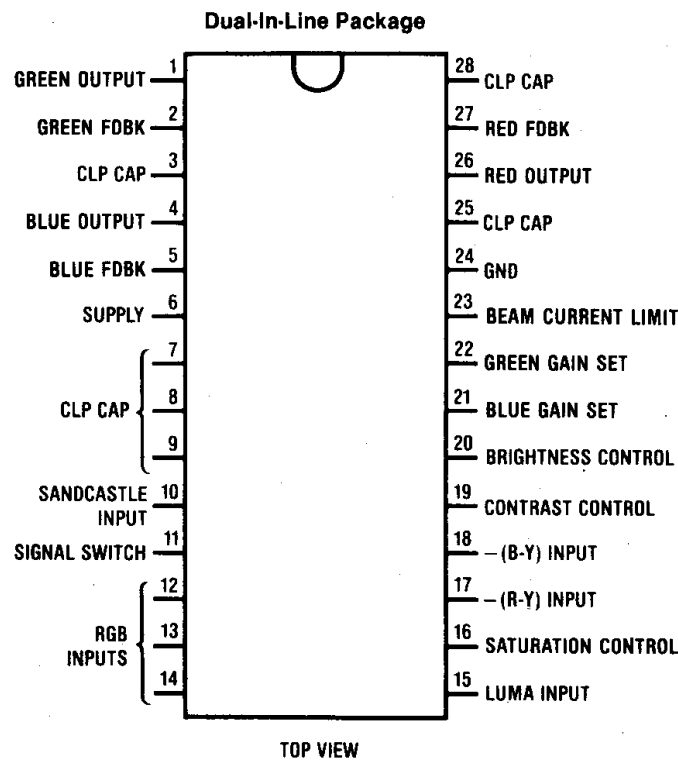

Order Number TDA3501N
See NS Package N28A

Electrical Characteristics $V_S = 12V, T_A = 25^\circ C$. The TDA3500 data applies except for the following parameters.

Parameter	Conditions	Min	Typ	Max	Units
CONTRAST CONTROL (Pin 19)					
I_{19}	Contrast Control Input Current	$V_{23} \geq 6V$		10	μA
I_{19}	Current Sinking	$V_{23} = 5.8V$	0.7		mA
		$V_{23} = 5.7V$	10		mA
		$V_{23} = 5.6V$	16		mA
BEAM CURRENT CONTROL (Pin 23)					
V23	Internal Bias Voltage (Pin 23)		6		V
R23	Input Impedance		10		k Ω

Block Diagram

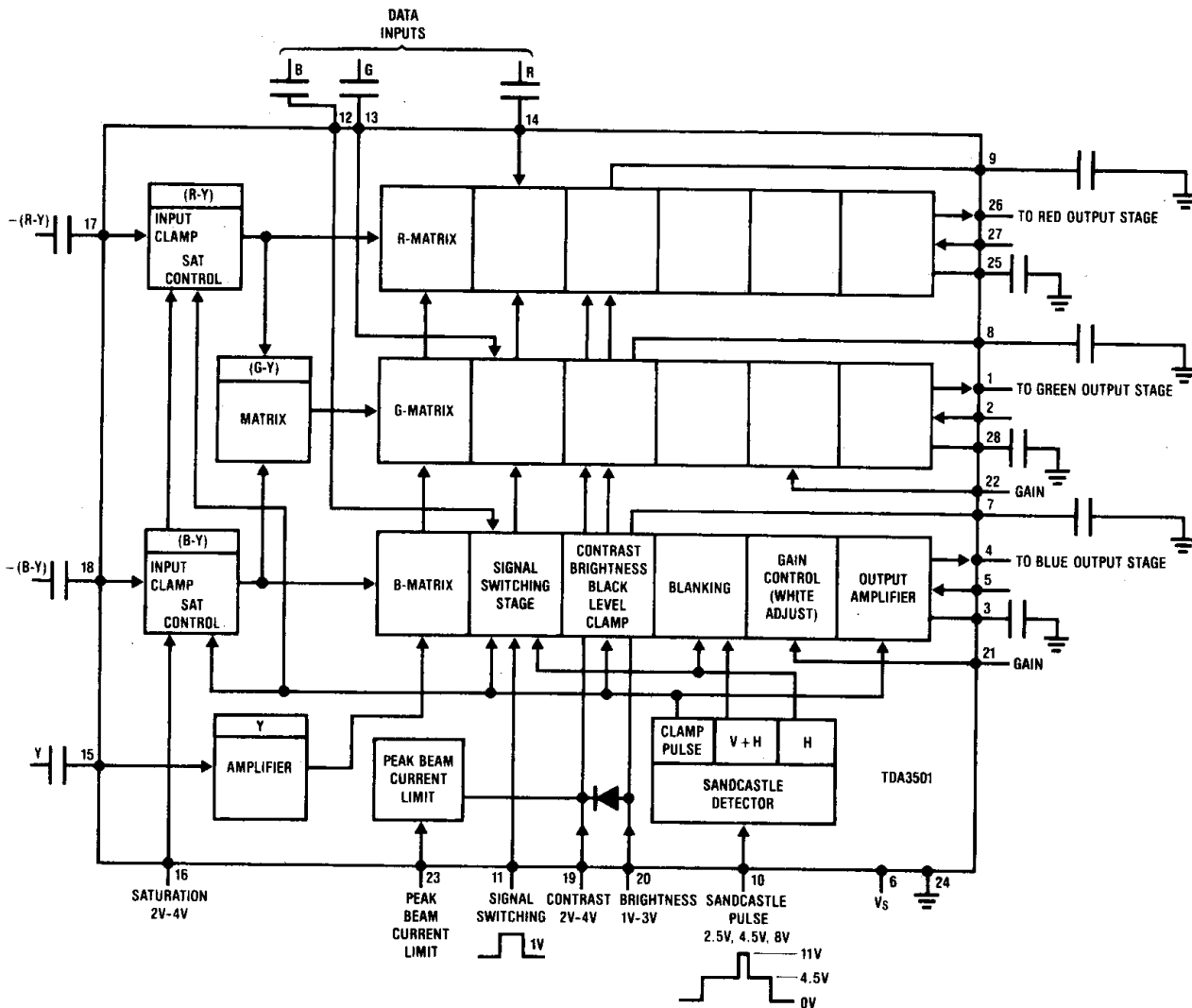

Typical Application and Test Circuit

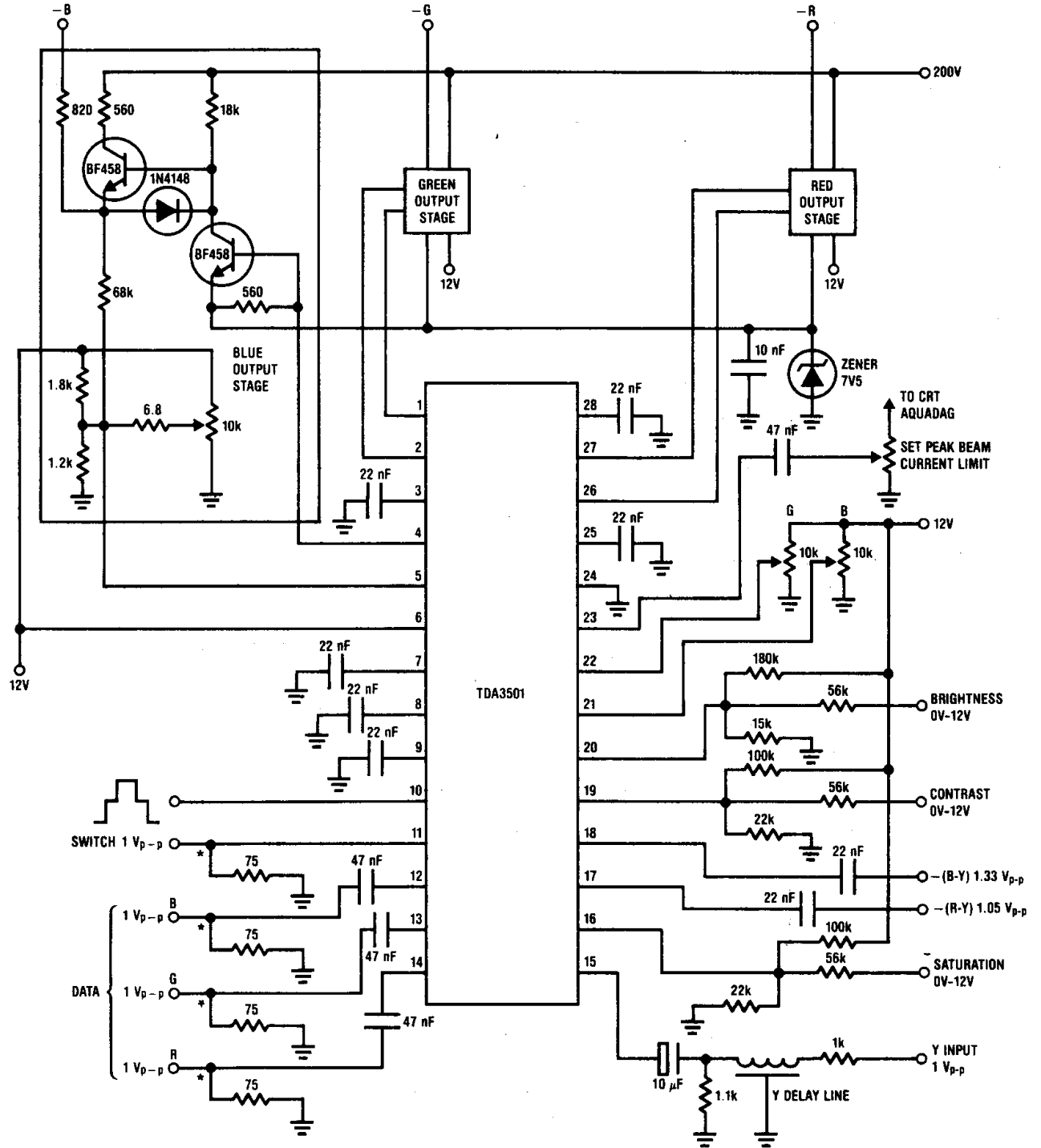

* Input termination 200Ω max