

DATA SHEET

TDA1522 Stereo cassette head preamplifier and equalizer

Product specification
File under Integrated Circuits, IC01

1996 Feb 26

Stereo cassette head preamplifier and equalizer

TDA1522

FEATURES

- Two independent amplifiers with open-loop gain of 90 dB (typical)
- Internal DC feedback via 140 k Ω resistor from output to feedback point
- AC characteristics that can be determined externally by an RC network
- Electronic on/off switching with transient suppression for switch on
- Head input at DC ground that eliminates the input coupling capacitor
- Minimum external component requirement
- Stability down to a gain of 30 dB
- Low input noise
- Low distortion
- DC input current <2 μ A
- Wide supply voltage range.

GENERAL DESCRIPTION

The TDA1522 is a playback amplifier for car radio/cassette players.

QUICK REFERENCE DATA

SYMBOL	PARAMETER	CONDITIONS	MIN.	TYP.	MAX.	UNIT
V _P	supply voltage (pin 8)		7.5	–	23	V
I _P	supply current (pin 8)		–	5	–	mA
T _{amb}	operating ambient temperature		–30	–	+85	°C
THD	total harmonic distortion		–	0.05	–	%
α_{cs}	channel separation	R _S = 10 k Ω ; L _S = 0	45	–	–	dB

ORDERING INFORMATION

TYPE NUMBER	PACKAGE		
	NAME	DESCRIPTION	VERSION
TDA1522	SIL9MP	plastic single in-line medium power package; 9 leads	SOT142-1

Stereo cassette head
preamplifier and equalizer

TDA1522

BLOCK DIAGRAM

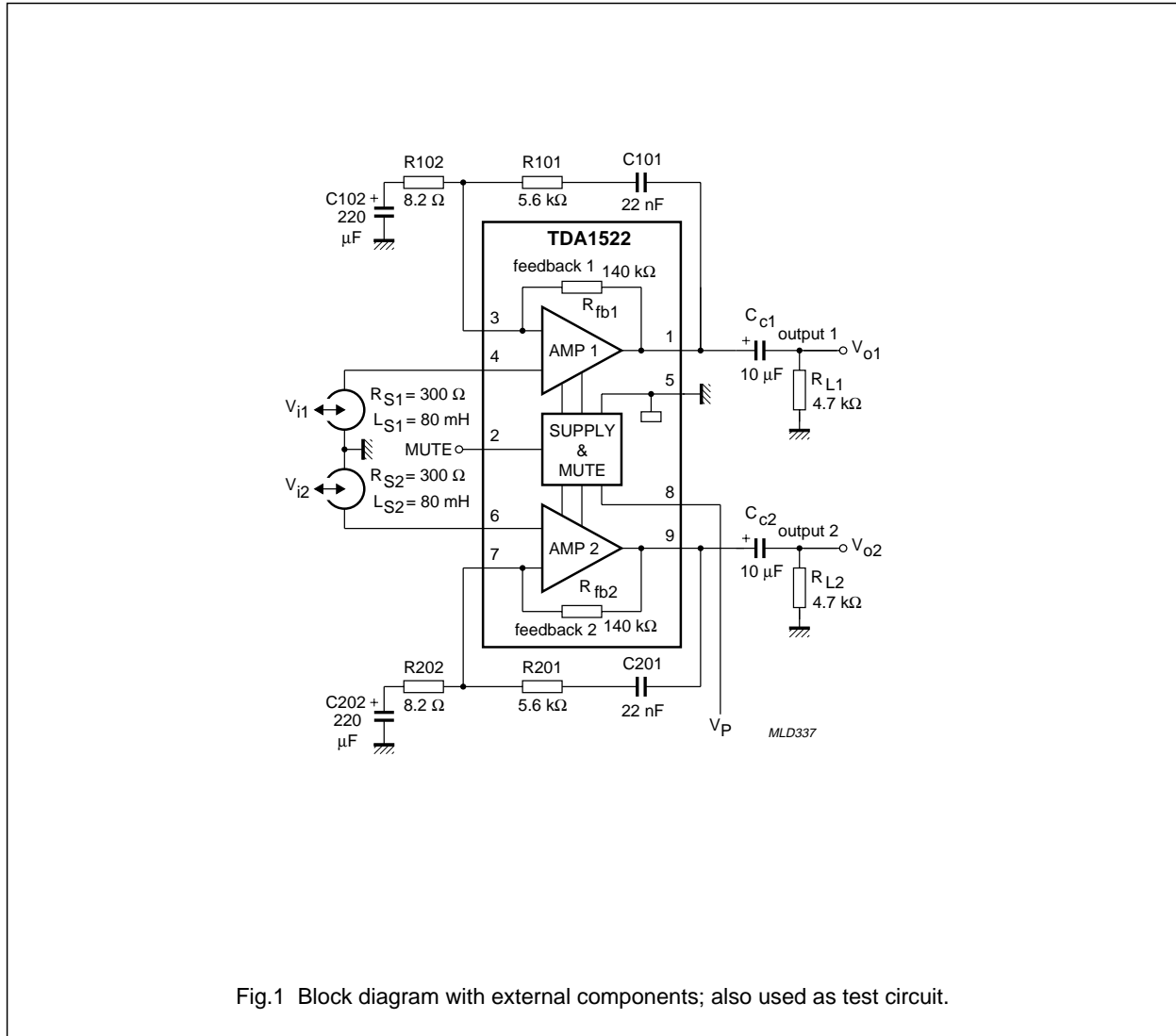

Fig.1 Block diagram with external components; also used as test circuit.

Stereo cassette head preamplifier and equalizer

TDA1522

PINNING

SYMBOL	PIN	DESCRIPTION
V_{o1}	1	output voltage 1
MUTE	2	mute input
FB1	3	feedback 1
V_{i1}	4	input voltage 1
GND	5	ground
V_{i2}	6	input voltage 2
FB2	7	feedback 2
V_P	8	power supply
V_{o2}	9	output voltage 2

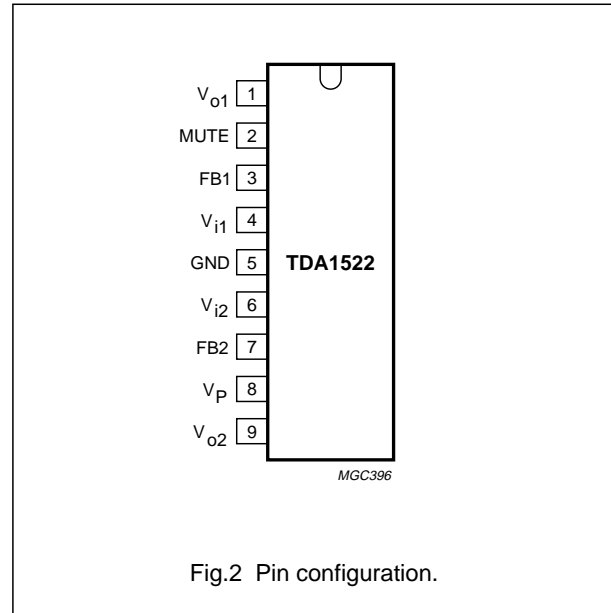

Stereo cassette head preamplifier and equalizer

TDA1522

LIMITING VALUES

In accordance with the Absolute Maximum Rating System (IEC 134); note 1.

SYMBOL	PARAMETER	MIN.	MAX.	UNIT
V_P	supply voltage (pin 8)	7.5	23	V
I_{fb}	feedback current (pins 3 and 7)	–	10	mA
P_{tot}	total power dissipation	–	800	mW
T_{amb}	operating ambient temperature	–30	+85	°C
T_{stg}	storage temperature	–55	+150	°C

Note

- All pins except 3 and 7 (feedback) can be connected to V_P (pin 8) or ground (pin 5).

CHARACTERISTICS

$V_P = 8.5$ V; $T_{amb} = 25$ °C; see test circuit Fig.1; unless otherwise specified.

SYMBOL	PARAMETER	CONDITIONS	MIN.	TYP.	MAX.	UNIT
Supply (pin 8)						
V_P	supply voltage		7.5	–	23	V
I_P	supply current		–	5	–	mA
Inputs (pins 4 or 6)						
$V_{ni(rms)}$	unweighted noise input voltage (RMS value)	$f = 20$ Hz to 20 kHz; measured in Fig.3	–	1.6	–	μ V
V_{ni}	noise input voltage	$R_S = 0$; $f = 1$ kHz; measured in Fig.3; see also Fig.5	–	5	–	$\frac{nV}{\sqrt{Hz}}$
I_{ni}	noise input current	$f = 1$ kHz; measured in Fig.3; see also Fig.6	–	1.2	–	$\frac{pA}{\sqrt{Hz}}$
I_4, I_6	DC input current at pins 4 and 6		–	–	–2	μ A
$ Z_i $	input impedance	$f = 1$ kHz; note 1	200	–	–	k Ω
Outputs (pins 1 or 9); see Fig.7						
V_o	output voltage	$V_i = 0.3$ mV; $f = 315$ Hz	–	0.72	–	V
		THD = 1%; $f = 1$ kHz	1.0	–	–	V
I_o	output source current	$V_{2-5} \geq 7.5$ V; mute off	–5	–10	–	mA
V_O	DC output voltage		–	3.7	–	V
$V_{no(rms)}$	weighted noise output voltage; DIN A (RMS value)	$R_S = 300$ Ω ; $L_S = 80$ mH	–	700	–	μ V
V_{no}	weighted noise output voltage CCITT (peak value) CCIR (peak value)	$R_S = 300$ Ω ; $L_S = 80$ mH	–	1200	–	μ V
		$R_S = 300$ Ω ; $L_S = 80$ mH	–	1600	–	μ V
V_{no}	unweighted noise output voltage; DIN 45405 (peak value)	$R_S = 300$ Ω ; $L_S = 80$ mH	–	1800	–	μ V
$ Z_o $	output impedance	$f = 1$ kHz; note 1	–	–	1	k Ω

Stereo cassette head preamplifier and equalizer

TDA1522

SYMBOL	PARAMETER	CONDITIONS	MIN.	TYP.	MAX.	UNIT
Mute on/off (pin 2); see Fig.4						
$V_{\text{mute(on)}}$	mute on voltage	mute switch closed	0	–	1	V
$I_{\text{mute(on)}}$	mute on current	mute switch closed or $V_{2-5} = 0$ V	–	2.7	–	μA
$V_{\text{mute(off)}}$	mute off voltage	mute switch open	7.5	–	V_P	V
General						
R_{fb}	internal feedback resistor	note 1	100	140	180	$\text{k}\Omega$
G_v	open-loop voltage gain	$f = 315$ Hz; note 1	–	90	–	dB
α_{cs}	channel separation	$R_S = 10$ $\text{k}\Omega$; $L_S = 0$; note 2	45	–	–	dB
PSRR	power supply ripple rejection	$V_{P(\text{rms})} = 0.1$ V; $f = 100$ Hz; note 3	90	95	–	dB
THD	total harmonic distortion	$f = 1$ kHz; $V_O = 0.3$ V; note 4	–	0.05	–	%

Notes

1. Applies to each amplifier.
2. Frequency range 300 Hz to 20 kHz.
3. Referred to the input.
4. Measured selective.

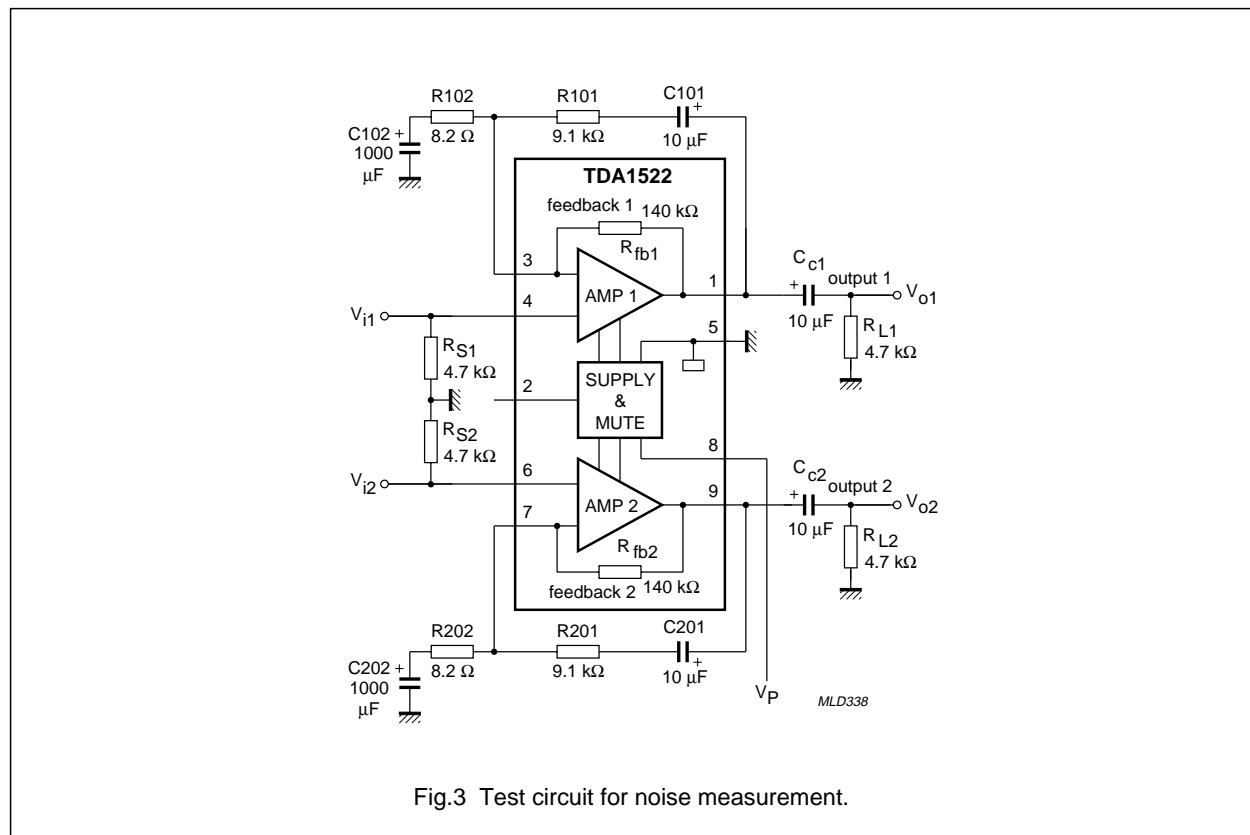
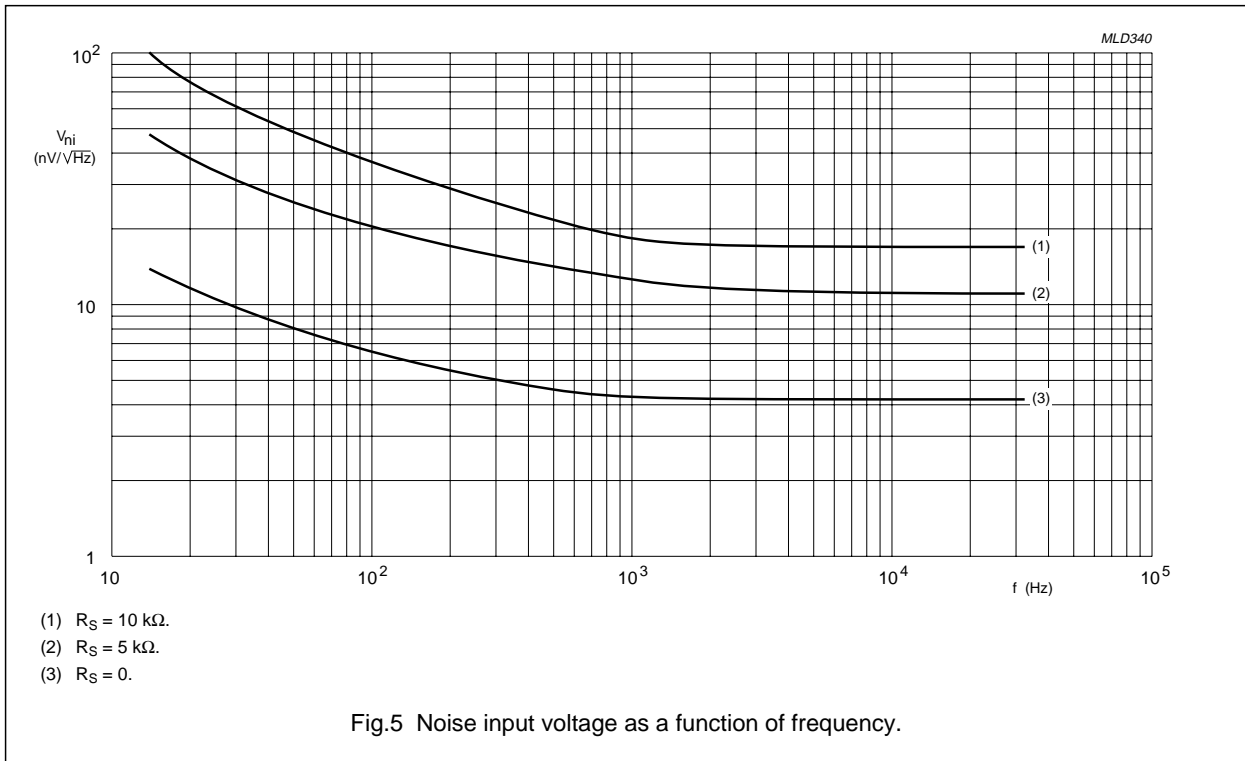
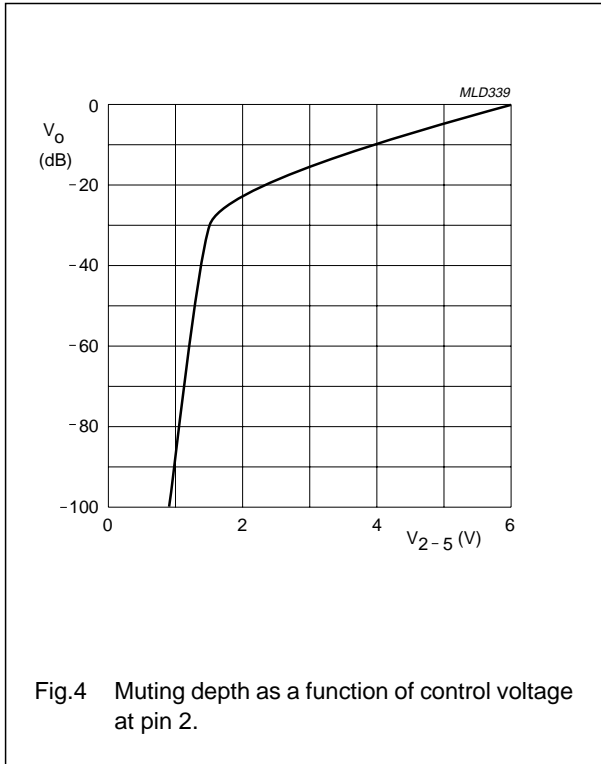

Fig.3 Test circuit for noise measurement.

Stereo cassette head
preamplifier and equalizer

TDA1522



Stereo cassette head
preamplifier and equalizer

TDA1522

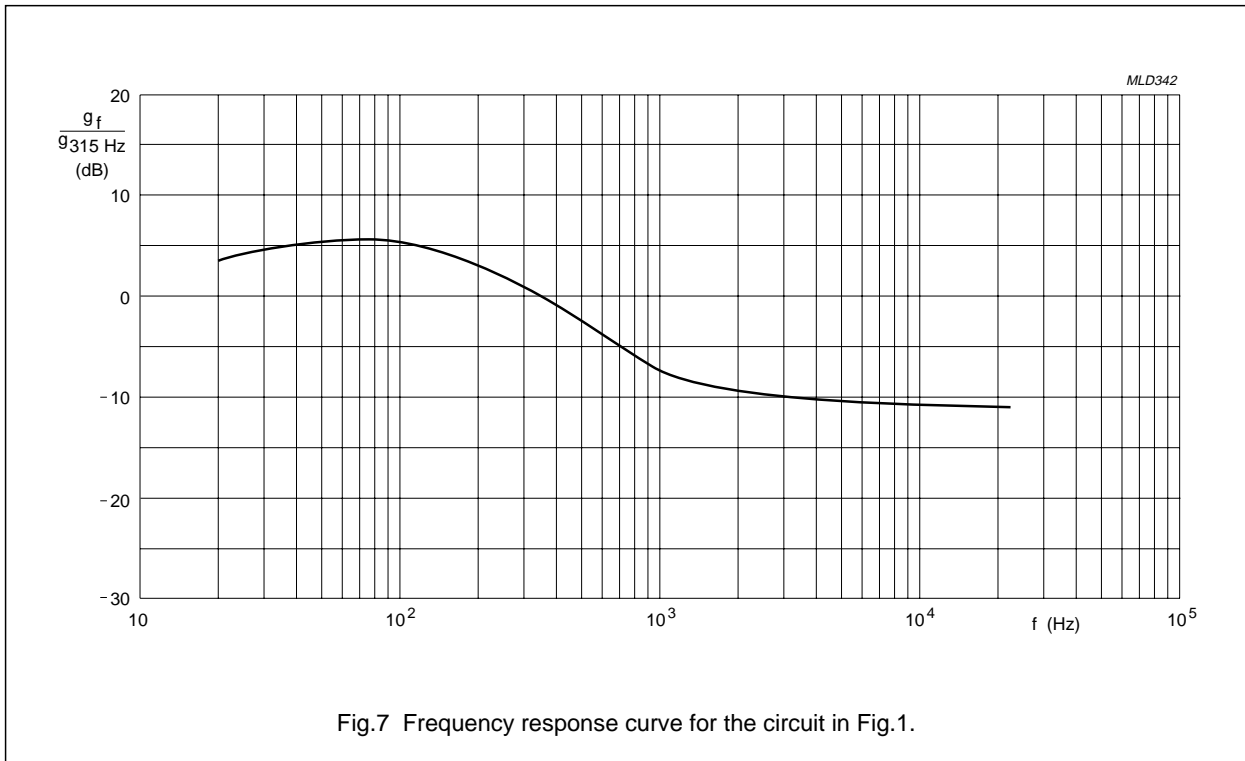
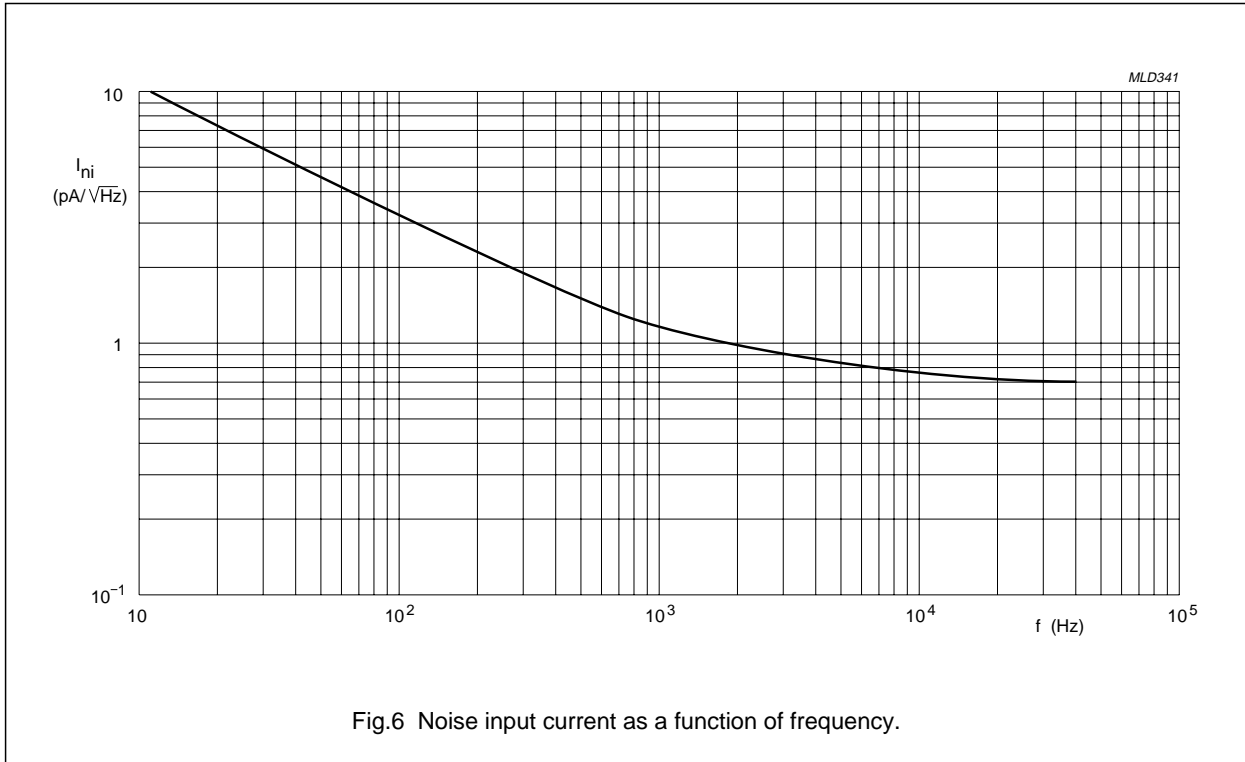

Stereo cassette head
preamplifier and equalizer

TDA1522

APPLICATION INFORMATION

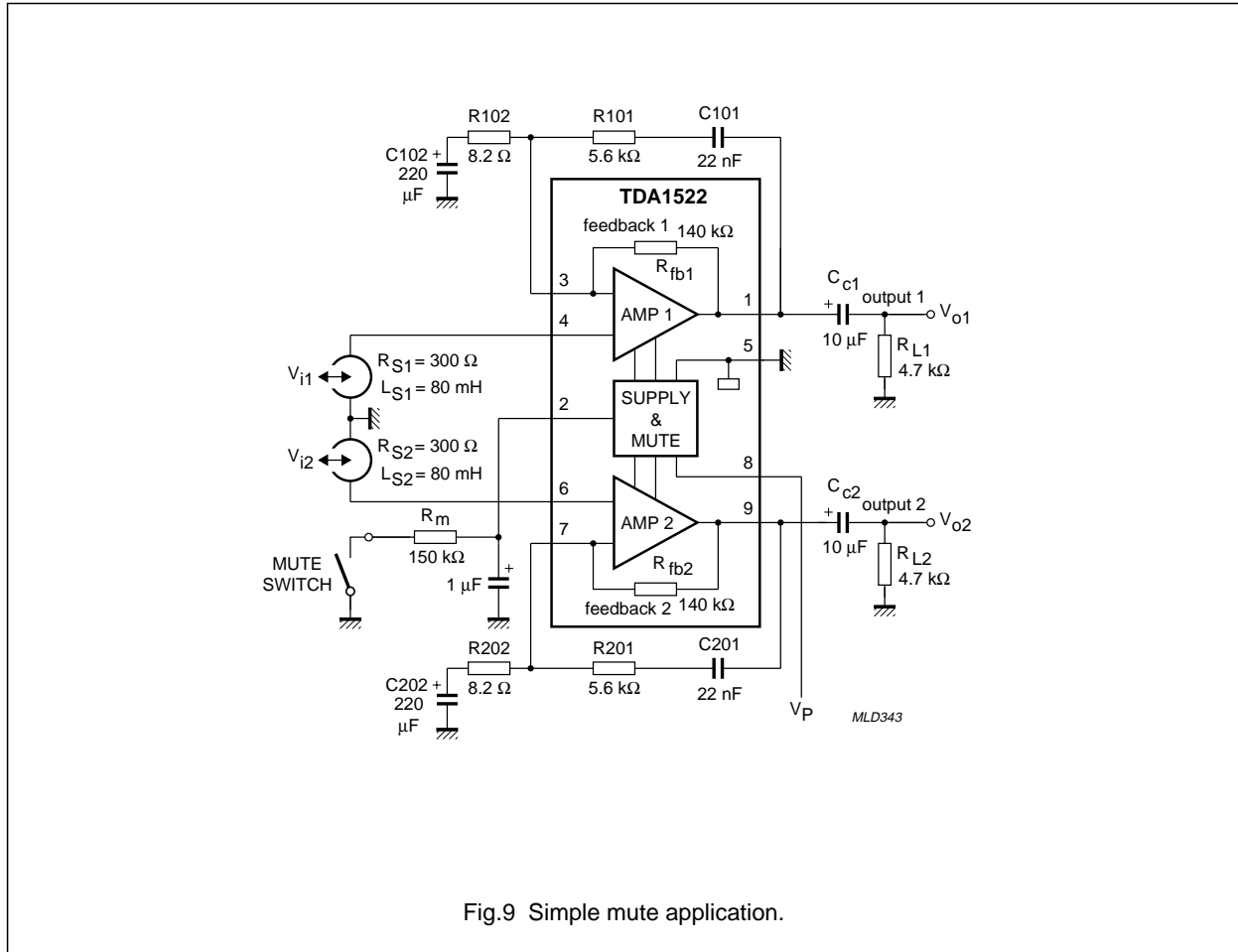

Fig.9 Simple mute application.

Stereo cassette head
preamplifier and equalizer

TDA1522

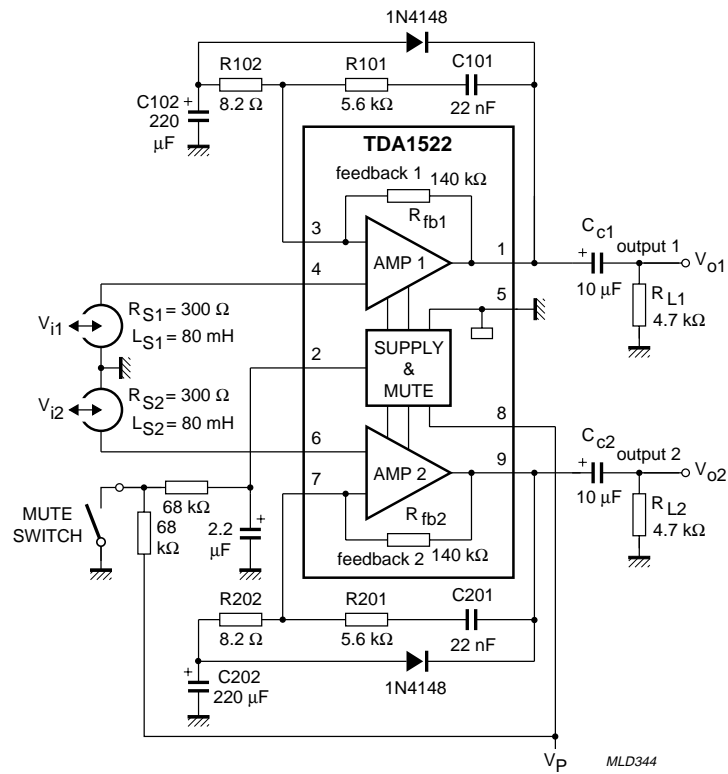

Fig.10 Application for pop-free muting.

Stereo cassette head
preamplifier and equalizer

TDA1522

PACKAGE OUTLINE

SIL9MP: plastic single in-line medium power package; 9 leads

SOT142-1

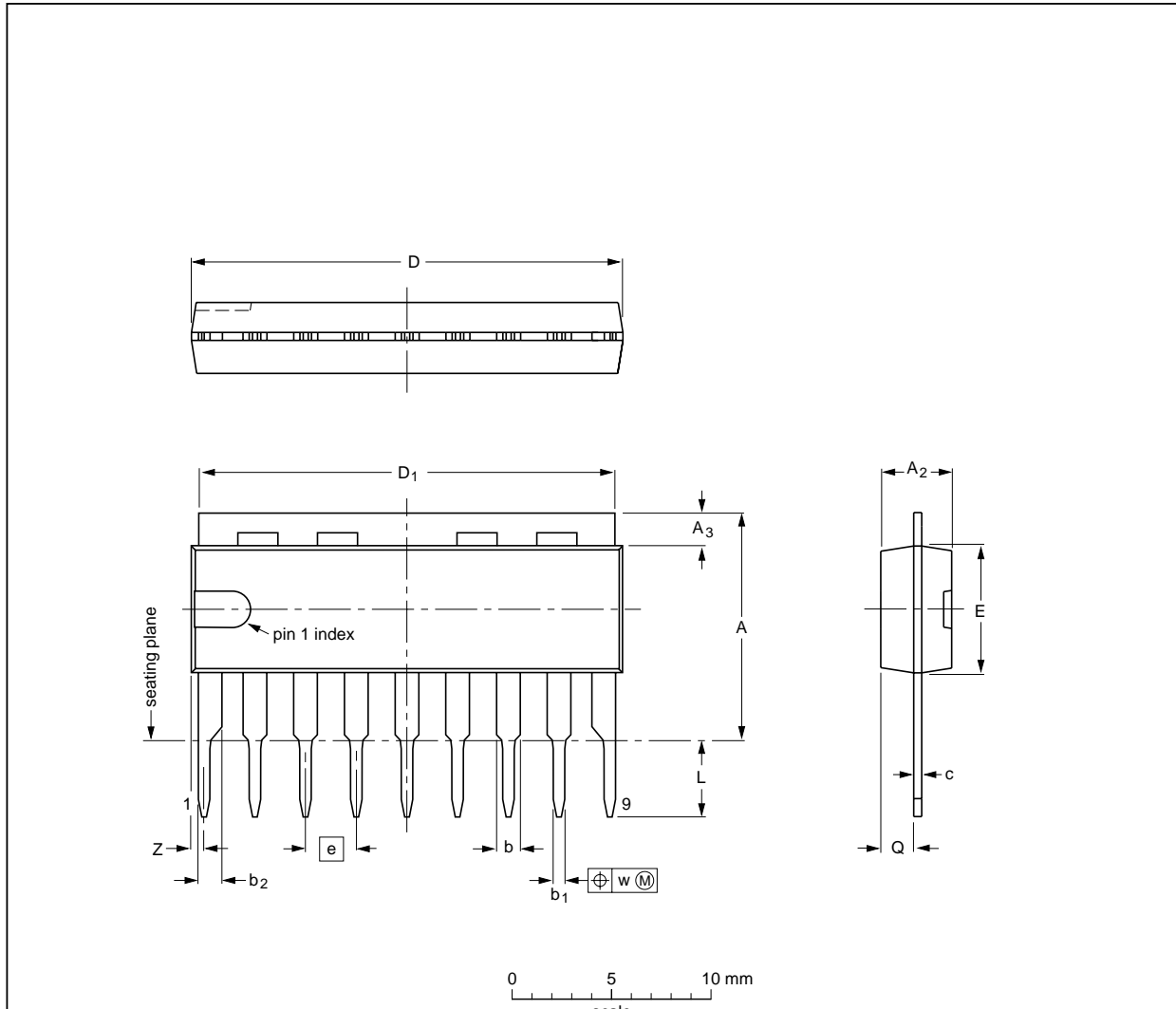

DIMENSIONS (mm are the original dimensions)

UNIT	A	A ₂ max.	A ₃	b	b ₁	b ₂	c	D ⁽¹⁾	D ₁	E ⁽¹⁾	e	L	Q	w	z ⁽¹⁾ max.
mm	12 11	3.7	1.8 1.4	1.40 1.14	0.67 0.50	1.40 1.14	0.48 0.38	21.8 21.4	21.4 20.7	6.48 6.20	2.54	3.9 3.4	1.75 1.55	0.25	1.0

Note

1. Plastic or metal protrusions of 0.25 mm maximum per side are not included.

OUTLINE VERSION	REFERENCES				EUROPEAN PROJECTION	ISSUE DATE
	IEC	JEDEC	EIAJ			
SOT142-1						92-11-17 95-02-09

Stereo cassette head preamplifier and equalizer

TDA1522

SOLDERING

Introduction

There is no soldering method that is ideal for all IC packages. Wave soldering is often preferred when through-hole and surface mounted components are mixed on one printed-circuit board. However, wave soldering is not always suitable for surface mounted ICs, or for printed-circuits with high population densities. In these situations reflow soldering is often used.

This text gives a very brief insight to a complex technology. A more in-depth account of soldering ICs can be found in our "IC Package Databook" (order code 9398 652 90011).

Soldering by dipping or by wave

The maximum permissible temperature of the solder is 260 °C; solder at this temperature must not be in contact with the joint for more than 5 seconds. The total contact time of successive solder waves must not exceed 5 seconds.

The device may be mounted up to the seating plane, but the temperature of the plastic body must not exceed the specified maximum storage temperature ($T_{stg\ max}$). If the printed-circuit board has been pre-heated, forced cooling may be necessary immediately after soldering to keep the temperature within the permissible limit.

Repairing soldered joints

Apply a low voltage soldering iron (less than 24 V) to the lead(s) of the package, below the seating plane or not more than 2 mm above it. If the temperature of the soldering iron bit is less than 300 °C it may remain in contact for up to 10 seconds. If the bit temperature is between 300 and 400 °C, contact may be up to 5 seconds.

DEFINITIONS

Data sheet status	
Objective specification	This data sheet contains target or goal specifications for product development.
Preliminary specification	This data sheet contains preliminary data; supplementary data may be published later.
Product specification	This data sheet contains final product specifications.
Limiting values	
Limiting values given are in accordance with the Absolute Maximum Rating System (IEC 134). Stress above one or more of the limiting values may cause permanent damage to the device. These are stress ratings only and operation of the device at these or at any other conditions above those given in the Characteristics sections of the specification is not implied. Exposure to limiting values for extended periods may affect device reliability.	
Application information	
Where application information is given, it is advisory and does not form part of the specification.	

LIFE SUPPORT APPLICATIONS

These products are not designed for use in life support appliances, devices, or systems where malfunction of these products can reasonably be expected to result in personal injury. Philips customers using or selling these products for use in such applications do so at their own risk and agree to fully indemnify Philips for any damages resulting from such improper use or sale.

Stereo cassette head
preamplifier and equalizer

TDA1522

NOTES

Stereo cassette head
preamplifier and equalizer

TDA1522

NOTES

Philips Semiconductors – a worldwide company

Argentina: IEROD, Av. Juramento 1992 - 14.b, (1428)
BUENOS AIRES, Tel. (541)786 7633, Fax. (541)786 9367

Australia: 34 Waterloo Road, NORTH RYDE, NSW 2113,
Tel. (02)805 4455, Fax. (02)805 4466

Austria: Triester Str. 64, A-1101 WIEN, P.O. Box 213,
Tel. (01)60 101-1236, Fax. (01)60 101-1211

Belgium: Postbus 90050, 5600 PB EINDHOVEN, The Netherlands,
Tel. (31)40-2783749, Fax. (31)40-2788399

Brazil: Rua do Rocio 220 - 5th floor, Suite 51,
CEP: 04552-903-SÃO PAULO-SP, Brazil,
P.O. Box 7383 (01064-970),
Tel. (011)821-2333, Fax. (011)829-1849

Canada: PHILIPS SEMICONDUCTORS/COMPONENTS:
Tel. (800) 234-7381, Fax. (708) 296-8556

Chile: Av. Santa Maria 0760, SANTIAGO,
Tel. (02)773 816, Fax. (02)777 6730

China/Hong Kong: 501 Hong Kong Industrial Technology Centre,
72 Tat Chee Avenue, Kowloon Tong, HONG KONG,
Tel. (852)2319 7888, Fax. (852)2319 7700

Colombia: IPRELENSO LTDA, Carrera 21 No. 56-17,
77621 BOGOTA, Tel. (571)249 7624/(571)217 4609,
Fax. (571)217 4549

Denmark: Prags Boulevard 80, PB 1919, DK-2300
COPENHAGEN S, Tel. (45)32 88 26 36, Fax. (45)31 57 19 49

Finland: Sinikalliontie 3, FIN-02630 ESPOO,
Tel. (358)0-615 800, Fax. (358)0-61580 920

France: 4 Rue du Port-aux-Vins, BP317,
92156 SURESNES Cedex,
Tel. (01)4099 6161, Fax. (01)4099 6427

Germany: P.O. Box 10 51 40, 20035 HAMBURG,
Tel. (040)23 53 60, Fax. (040)23 53 63 00

Greece: No. 15, 25th March Street, GR 17778 TAVROS,
Tel. (01)4894 339/4894 911, Fax. (01)4814 240

India: Philips INDIA Ltd, Shivsagar Estate, A Block,
Dr. Annie Besant Rd. Worli, Bombay 400 018
Tel. (022)4938 541, Fax. (022)4938 722

Indonesia: Philips House, Jalan H.R. Rasuna Said Kav. 3-4,
P.O. Box 4252, JAKARTA 12950,
Tel. (021)5201 122, Fax. (021)5205 189

Ireland: Newstead, Clonskeagh, DUBLIN 14,
Tel. (01)7640 000, Fax. (01)7640 200

Italy: PHILIPS SEMICONDUCTORS S.r.l.,
Piazza IV Novembre 3, 20124 MILANO,
Tel. (0039)2 6752 2531, Fax. (0039)2 6752 2557

Japan: Philips Bldg 13-37, Kohnan2-chome, Minato-ku, TOKYO 108,
Tel. (03)3740 5130, Fax. (03)3740 5077

Korea: Philips House, 260-199 Itaewon-dong,
Yongsan-ku, SEOUL, Tel. (02)709-1412, Fax. (02)709-1415

Malaysia: No. 76 Jalan Universiti, 46200 PETALING JAYA,
SELANGOR, Tel. (03)750 5214, Fax. (03)757 4880

Mexico: 5900 Gateway East, Suite 200, EL PASO, TX 79905,
Tel. 9-5(800)234-7381, Fax. (708)296-8556

Netherlands: Postbus 90050, 5600 PB EINDHOVEN, Bldg. VB,
Tel. (040)2783749, Fax. (040)2788399

New Zealand: 2 Wagener Place, C.P.O. Box 1041, AUCKLAND,
Tel. (09)849-4160, Fax. (09)849-7811

Norway: Box 1, Manglerud 0612, OSLO,
Tel. (022)74 8000, Fax. (022)74 8341

Pakistan: Philips Electrical Industries of Pakistan Ltd.,
Exchange Bldg. ST-2/A, Block 9, KDA Scheme 5, Clifton,
KARACHI 75600, Tel. (021)587 4641-49,
Fax. (021)577035/5874546

Philippines: PHILIPS SEMICONDUCTORS PHILIPPINES Inc.,
106 Valero St. Salcedo Village, P.O. Box 2108 MCC, MAKATI,
Metro MANILA, Tel. (63) 2 816 6380, Fax. (63) 2 817 3474

Portugal: PHILIPS PORTUGUESA, S.A.,
Rua dr. António Loureiro Borges 5, Arquiparque - Miraflores,
Apartado 300, 2795 LINDA-A-VELHA,
Tel. (01)4163160/4163333, Fax. (01)4163174/4163366

Singapore: Lorong 1, Toa Payoh, SINGAPORE 1231,
Tel. (65)350 2000, Fax. (65)251 6500

South Africa: S.A. PHILIPS Pty Ltd.,
195-215 Main Road Martindale, 2092 JOHANNESBURG,
P.O. Box 7430, Johannesburg 2000,
Tel. (011)470-5911, Fax. (011)470-5494

Spain: Balmes 22, 08007 BARCELONA,
Tel. (03)301 6312, Fax. (03)301 42 43

Sweden: Kottbygatan 7, Akalla. S-164 85 STOCKHOLM,
Tel. (0)8-632 2000, Fax. (0)8-632 2745

Switzerland: Allmendstrasse 140, CH-8027 ZÜRICH,
Tel. (01)488 2211, Fax. (01)481 77 30

Taiwan: PHILIPS TAIWAN Ltd., 23-30F, 66, Chung Hsiao West
Road, Sec. 1. Taipei, Taiwan ROC, P.O. Box 22978,
TAIPEI 100, Tel. (886) 2 382 4443, Fax. (886) 2 382 4444

Thailand: PHILIPS ELECTRONICS (THAILAND) Ltd.,
209/2 Sanpavuth-Bangna Road Prakanong,
Bangkok 10260, THAILAND,
Tel. (66) 2 745-4090, Fax. (66) 2 398-0793

Turkey: Talatpasa Cad. No. 5, 80640 GÜLTEPE/ISTANBUL,
Tel. (0212)279 27 70, Fax. (0212)282 67 07

Ukraine: Philips UKRAINE, 2A Akademika Koroleva str., Office 165,
252148 KIEV, Tel. 380-44-4760297, Fax. 380-44-4766991

United Kingdom: Philips Semiconductors LTD.,
276 Bath Road, Hayes, MIDDLESEX UB3 5BX,
Tel. (0181)730-5000, Fax. (0181)754-8421

United States: 811 East Arques Avenue, SUNNYVALE,
CA 94088-3409, Tel. (800)234-7381, Fax. (708)296-8556

Uruguay: Coronel Mora 433, MONTEVIDEO,
Tel. (02)70-4044, Fax. (02)92 0601

Internet: <http://www.semiconductors.philips.com/ps/>

For all other countries apply to: Philips Semiconductors,
International Marketing and Sales, Building BE-p,
P.O. Box 218, 5600 MD EINDHOVEN, The Netherlands,
Telex 35000 phtnl, Fax. +31-40-2724825

SCDS47

© Philips Electronics N.V. 1996

All rights are reserved. Reproduction in whole or in part is prohibited without the prior written consent of the copyright owner.

The information presented in this document does not form part of any quotation or contract, is believed to be accurate and reliable and may be changed without notice. No liability will be accepted by the publisher for any consequence of its use. Publication thereof does not convey nor imply any license under patent- or other industrial or intellectual property rights.

Printed in The Netherlands

517021/1100/01/pp16
Document order number:

Date of release: 1996 Feb 26
9397 750 00693