

DATA SHEET

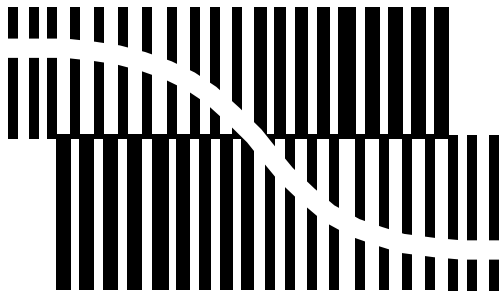

BITSTREAM CONVERSION

TDA1388

Bitstream continuous calibration
filter-DAC for CD-ROM audio
applications

Objective specification
Supersedes data of 1995 Dec 08
File under Integrated Circuits, IC01

1996 Jul 17

Bitstream continuous calibration filter-DAC for CD-ROM audio applications

TDA1388

FEATURES

Multiple format input interface

- I²S-bus and LSB-justified input format compatible
- $1f_s$ input format data rate.

Extensive channel manipulation features

- Separate soft mute on left and right channel
- Channel interchange function (left to right and right to left)
- Monaural function (left to right or right to left)
- True mono function $\frac{1}{2}$ (left plus right).

Digital sound processing

- Separate digital volume control for left and right channels
- Digital tone control, bass boost and treble
- dB-linear volume and tone control (low microcontroller load)
- Digital de-emphasis
- Soft mute.

Advanced audio output configuration

- Stereo line output (under microcontroller volume control)
- Stereo headphone output (under 5-tap potentiometer volume control)
- Line output independent of headphone output volume
- Power on/off click prevention circuitry
- High linearity, dynamic range, low distortion.

General

- Integrated digital filter plus DAC plus headphone driver
- No analog post filter required
- Easy application
- Functions controllable by static pins or by microcontroller interface
- 5 V power supply
- Low power consumption
- Small package size (SO28 and SSOP28).

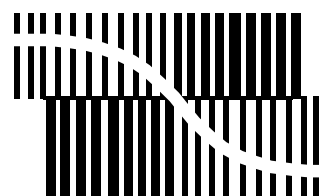

BITSTREAM CONVERSION

GENERAL DESCRIPTION

The TDA1388 CMOS digital-to-analog bitstream converter incorporates an up-sampling digital filter and noise shaper, unique signal processing features and integrated line and headphone drivers. The digital processing features are of high sound quality due to the wide dynamic range of the bitstream conversion technique.

The TDA1388 supports the I²S-bus data input mode with word lengths of up to 20 bits and the LSB justified serial data input format with word lengths of 16, 18 and 20 bits. Two cascaded half-band filters and a sample-and-hold function increase the oversampling rate from $1f_s$ to $64f_s$. A 2nd-order noise shaper converts this oversampled data to a bitstream for the 5-bit continuous calibration Digital-to-Analog Converters (DACs).

On board amplifiers convert the output current to a voltage signal capable of driving a line output. The signal is also used to feed the integrated headphone amplifiers. The volume of the headphone is controlled by an external potentiometer.

The TDA1388 has special sound processing features for use in CD-ROM audio applications, which can be controlled by static pins or microcontroller interface. These functions are de-emphasis, volume, bass boost, treble, soft mute and the channel manipulation functions needed for ATAPI-compliant functionality in CD-ROM audio processing.

Bitstream continuous calibration filter-DAC for CD-ROM audio applications

TDA1388

ORDERING INFORMATION

| TYPE NUMBER | PACKAGE | | |
|-------------|---------|--|----------|
| | NAME | DESCRIPTION | VERSION |
| TDA1388T | SO28 | plastic small outline package; 28 leads; body width 7.5 mm. | SOT136-1 |
| TDA1388M | SSOP28 | plastic shrink small outline package; 28 leads; body width 5.3 mm. | SOT341-1 |

QUICK REFERENCE DATA

| SYMBOL | PARAMETER | CONDITIONS | MIN. | TYP. | MAX. | UNIT |
|--|---|--|-------|---------|--------|------|
| Supply | | | | | | |
| V_{DD} | supply voltage | note 1 | 4.5 | 5.0 | 5.5 | V |
| I_{DD} | supply current | note 2 | – | 22 | – | mA |
| $V_{FS(rms)}$ | full-scale output voltage (RMS value) | $V_{DD} = 5\text{ V}$ | 0.9 | 1.0 | 1.1 | V |
| (THD+N)/S | total harmonic distortion plus noise as a function of signal for the line output | 0 dB signal; $R_L = 5\text{ k}\Omega$ | – | –85 | –80 | dB |
| | | –60 dB signal; $R_L = 5\text{ k}\Omega$ | – | 0.006 | 0.013 | % |
| | | –60 dB signal; $R_L = 5\text{ k}\Omega$ | – | –35 | –30 | dBA |
| | | –60 dB signal; $R_L = 5\text{ k}\Omega$ | – | 1.8 | 3.2 | % |
| | total harmonic distortion plus noise as a function of signal for the headphone output | 0 dB signal; $R_L = 16\text{ }\Omega$ | – | –65 | – | dB |
| | | 0 dB signal; $R_L = 16\text{ }\Omega$ | – | 0.056 | – | % |
| | | 0 dB signal; $R_L = 32\text{ }\Omega$ | – | –70 | – | dB |
| | | 0 dB signal; $R_L = 32\text{ }\Omega$ | – | 0.032 | – | % |
| –60 dB signal; $R_L = 16\text{ }\Omega$ or $R_L = 32\text{ }\Omega$ | – | –35 | –30 | dBA | | |
| | – | 1.8 | 3.2 | % | | |
| S/N | signal-to-noise ratio | A-weighted; at code 00000H | 90 | 95 | – | dBA |
| BR | input bit rate at data input | $f_{sys} = 256f_s$ | – | $64f_s$ | – | bits |
| | | $f_{sys} = 384f_s$ | – | $48f_s$ | – | bits |
| f_{sys} | system clock frequency | | 8.192 | – | 18.432 | MHz |
| T_{amb} | operating ambient temperature | | –20 | – | +70 | °C |

Notes

- All V_{DD} and V_{SS} pins must be connected to the same supply or ground respectively.
- Measured at input code 00000H and $V_{DD} = 5\text{ V}$.

Bitstream continuous calibration filter-DAC for CD-ROM audio applications

TDA1388

BLOCK DIAGRAM

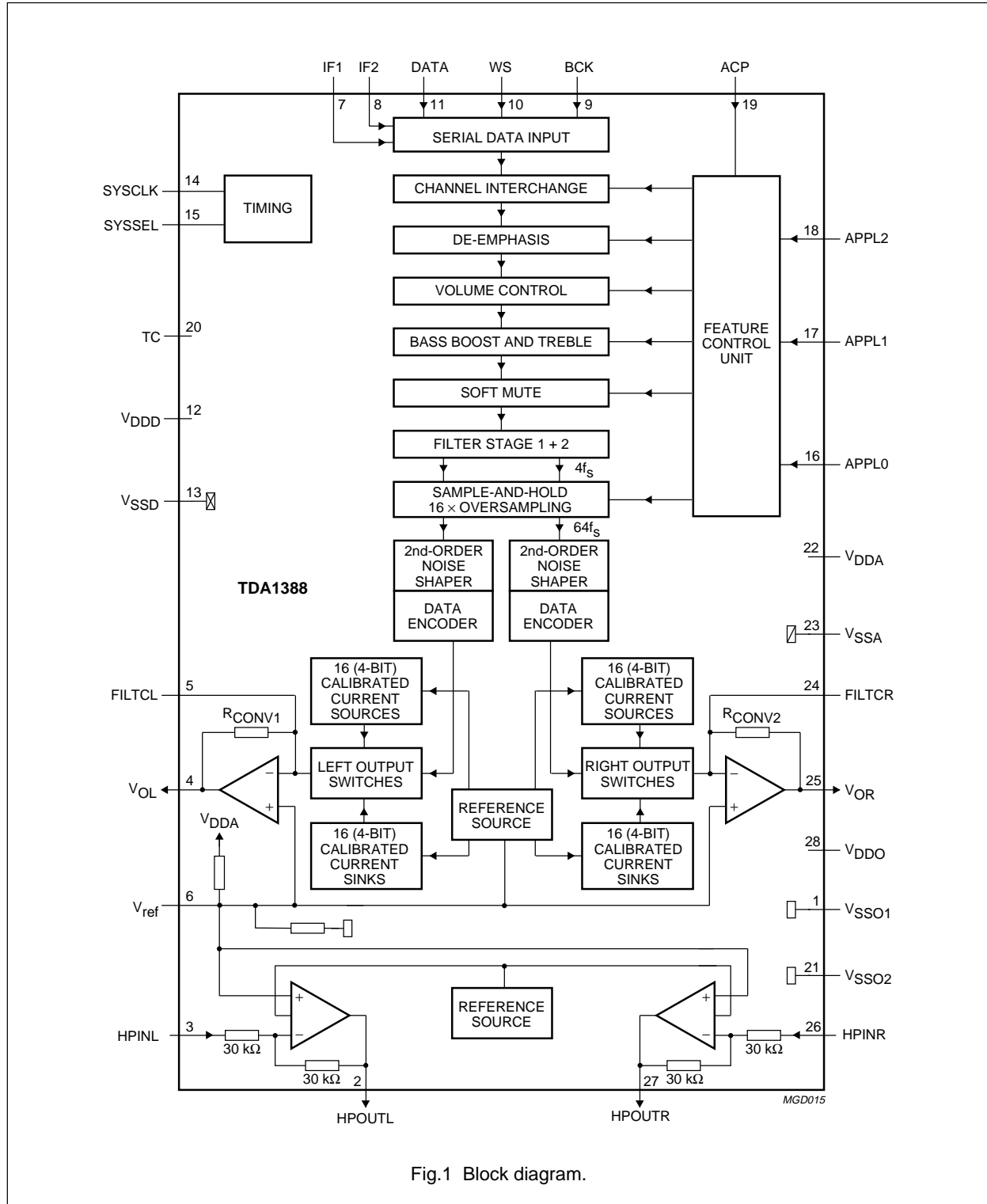

Fig.1 Block diagram.

Bitstream continuous calibration filter-DAC for CD-ROM audio applications

TDA1388

PINNING

| SYMBOL | PIN | DESCRIPTION |
|-------------------|-----|--|
| V _{SSO1} | 1 | operational amplifier ground 1 |
| HPOUTL | 2 | left headphone output voltage |
| HPINL | 3 | left headphone input voltage |
| V _{OL} | 4 | left channel audio voltage output |
| FILTCL | 5 | capacitor for left channel 1st-order filter function, should be connected between this pin and V _{OL} (pin 4) |
| V _{ref} | 6 | internal reference voltage |
| IF1 | 7 | input format selection 1 |
| IF2 | 8 | input format selection 2 |
| BCK | 9 | bit clock input |
| WS | 10 | word selection input |
| DATA | 11 | data input |
| V _{DDD} | 12 | digital supply voltage |
| V _{SSD} | 13 | digital ground |
| SYSCLK | 14 | system clock 256f _s or 384f _s |
| SYSSEL | 15 | system clock selection |
| APPL0 | 16 | application mode 0 input |
| APPL1 | 17 | application mode 1 input |
| APPL2 | 18 | application mode 2 input |
| ACP | 19 | application control input |
| TC | 20 | test control |
| V _{SSO2} | 21 | operational amplifier ground 2 |
| V _{DDA} | 22 | analog supply voltage |
| V _{SSA} | 23 | analog ground |
| FILTCL | 24 | capacitor for right channel 1st-order filter function, should be connected between this pin and V _{OR} (pin 25) |
| V _{OR} | 25 | right channel audio voltage output |
| HPINR | 26 | right headphone input voltage |
| HPOUTR | 27 | right headphone output voltage |
| V _{DDO} | 28 | operational amplifier supply voltage |

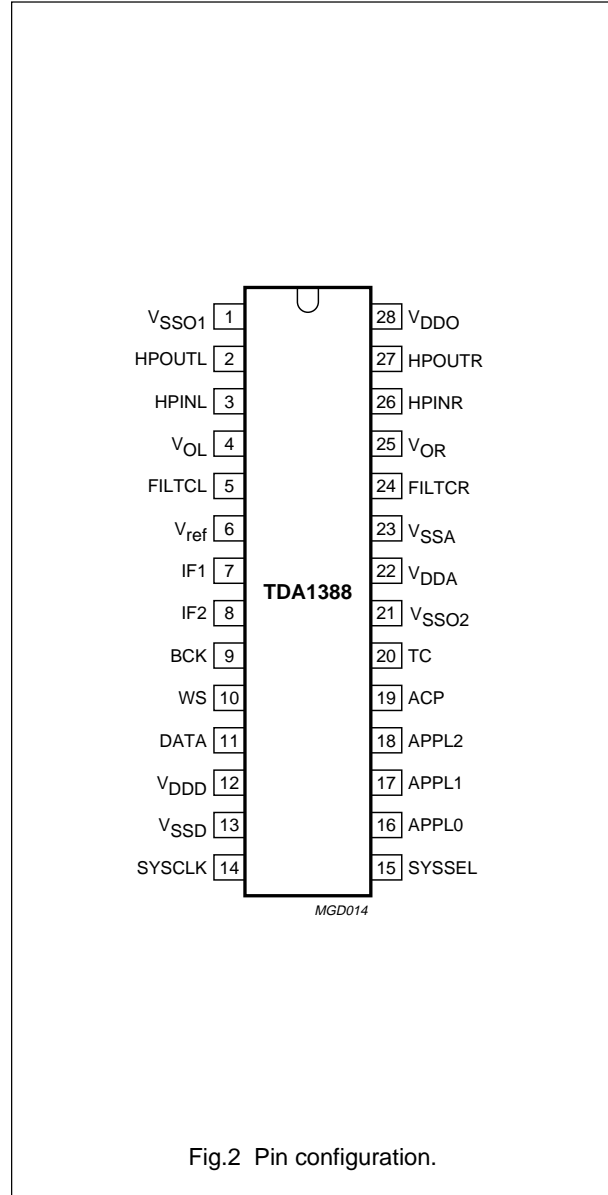

Bitstream continuous calibration filter-DAC for CD-ROM audio applications

TDA1388

FUNCTIONAL DESCRIPTION

The TDA1388 CMOS DAC incorporates an up-sampling digital filter, a sample-and-hold register, a noise shaper, continuously calibrated current sources, line amplifiers and headphone amplifiers. The $1f_s$ input data is increased to an oversampled rate of $64f_s$. This high-rate oversampling, together with the 5-bit DAC, enables the filtering required for waveform smoothing and out-of-band noise reduction to be achieved by simple 1st-order analog post-filtering.

System clock

The TDA1388 accommodates slave mode only, this means that in all applications the system devices must provide the system clock. The system frequency is selectable. The options are $256f_s$ and $384f_s$. The system clock must be locked in frequency to the I²S-bus input signals.

Table 1 System clock selection

| SYSSEL | DESCRIPTION |
|--------|-------------|
| 0 | $256f_s$ |
| 1 | $384f_s$ |

Multiple format input interface

The TDA1388 supports the following data input formats;

- I²S-bus with data word length of up to 20 bits.
- LSB justified serial format with data word length of 16, 18 or 20 bits.

Table 2 Data input formats

| IF1 | IF2 | FORMAT |
|-----|-----|------------------------|
| 0 | 0 | I ² S-bus |
| 0 | 1 | LSB-justified, 16 bits |
| 1 | 0 | LSB-justified, 18 bits |
| 1 | 1 | LSB-justified, 20 bits |

The input formats are illustrated in Fig.3. Left and right data-channel words are time multiplexed.

Input mode

The TDA1388 has two input modes, a static-pin mode and a microcontroller mode. In the static-pin mode, the digital sound processing features such as mute left, mute right and de-emphasis are controlled by external pins. The other digital sound processing features have a default value. In the microcontroller mode, all the digital sound processing features can be controlled by the microcontroller. The controllable features are:

- De-emphasis
- Volume left channel
- Volume right channel
- Flat/min/max switch
- Bass boost
- Treble
- Channel manipulation modes.

The selection of one of the two modes is controlled by the ACP pin. When this pin is at logic 0 then the static pin mode will be selected. When the pin is at logic 1 then the microcontroller mode will be selected.

Table 3 Selectable values of the digital sound processing features

| FEATURES | STATIC-PIN MODE | MICROCONTROLLER MODE |
|----------------------------|-----------------------|---------------------------|
| De-emphasis | 0 Hz or 44.1 kHz | 0 Hz or 44.1 kHz |
| Volume left channel | 0 dB (fixed) | 0 dB to $-\infty$ dB |
| Volume right channel | 0 dB (fixed) | 0 dB to $-\infty$ dB |
| Flat/min/max switch | flat (fixed) | flat/min/max |
| Bass boost | flat set (fixed) | flat, min or max set |
| Treble | flat set (fixed) | flat, min or max set |
| Mute left channel | external pin | selectable (see Table 4) |
| Mute right channel | external pin | selectable (see Table 4) |
| Channel manipulation modes | L_CHANNEL = L (fixed) | selectable (see Table 10) |
| | R_CHANNEL = R (fixed) | |

Bitstream continuous calibration filter-DAC for CD-ROM audio applications

TDA1388

STATIC-PIN MODE

In the static-pin mode most of the features have a default value (see Table 3). The features that are controlled by the external pins are, mute left channel, mute right channel and de-emphasis.

Table 4 External pin feature control in the static-pin mode

| PIN | FEATURE |
|-------|--------------------|
| APPL0 | mute left channel |
| APPL1 | mute right channel |
| APPL2 | de-emphasis |

MICROCONTROLLER MODE

The exchange of data and control information between the microcontroller and the TDA1388 is accomplished through a serial hardware interface comprising the following pins:

APPL0: microcontroller interface data line.

APPL1: microcontroller interface mode line.

APPL2: microcontroller interface clock line.

Information transfer through the microcontroller bus is organized in accordance with the so-called 'L3' format, in which two different modes of operation can be distinguished; address mode and data transfer mode (see Figs 4 and 5).

The address mode is required to select a device communicating via the L3-bus and to define the destination registers for the data transfer mode. Data transfer for the TDA1388 can only be in one direction, input to the TDA1388 to program its sound processing and other functional features.

Address mode

The address mode is used to select a device for subsequent data transfer and to define the destination registers. The address mode is characterized by APPL1 being LOW and a burst of 8 pulses on APPL2, accompanied by 8 data bits. The fundamental timing is shown in Fig.4. Data bits 0 to 1 indicate the type of the subsequent data transfer as shown in Table 5.

Table 5 Selection of data transfer

| BIT 1 | BIT 0 | TRANSFER |
|-------|-------|---|
| 0 | 0 | data (volume left, volume right, bass boost and treble) |
| 0 | 1 | not used |
| 1 | 0 | status (de-emphasis, mode and channel-manipulation) |
| 1 | 1 | not used |

Data bits 7 to 2 represent a 6-bit device address, with bit 7 being the MSB and bit 2 the LSB. The address of the TDA1388 is 000101 (bit 7 to bit 2). In the event that the TDA1388 receives a different address, it will deselect its microcontroller interface logic.

Data transfer mode

The selection performed in the address mode remains active during subsequent data transfers, until the TDA1388 receives a new address command. The fundamental timing of data transfers is essentially the same as in the address mode, shown in Fig.4. The maximum input clock and data rate is $64f_s$. All transfers are bitwise, i.e. they are based on groups of 8 bits. Data will be stored in the TDA1388 after the eighth bit of a byte has been received. A multibyte transfer is illustrated in Fig.6.

Programming the sound processing and other features

The sound processing and other feature values are stored in independent registers. The first selection of the registers is achieved by the choice of data type that is transferred. This is performed in the address mode, BIT 1 and BIT 0 (see Table 5). The second selection is performed by the 2 MSBs of the data byte (BIT 7 and BIT 6). The other bits in the data byte (BIT 5 to BIT 0) is the value that is placed in the selected registers.

When the data transfer of type 'data' is selected, the features VOLUME_R, VOLUME_L, BASS BOOST and TREBLE can be controlled. When the data transfer of type 'status' is selected, the features MODE, DE-EMPHASIS, CHANNEL_MANIP_R and CHANNEL_MANIP_L can be controlled.

Table 6 Data transfer of type 'status'

| BIT 7 | BIT 6 | BIT 5 | BIT 4 | BIT 3 | BIT 2 | BIT 1 | BIT 0 | REGISTER SELECTED |
|-------|-------|-------|-------|-------|-------|-------|-------|--|
| 0 | M1 | M0 | DE | OR1 | OR0 | OL1 | OL0 | MODE (1 : 0), DEEMPHASIS, CHANNEL_MANIP_R (1 : 0), CHANNEL_MANIP_L (1 : 0) |

Bitstream continuous calibration filter-DAC for CD-ROM audio applications

TDA1388

Table 7 Data transfer of type 'data'

| BIT 7 | BIT 6 | BIT 5 | BIT 4 | BIT 3 | BIT 2 | BIT 1 | BIT 0 | REGISTER SELECTED |
|-------|-------|------------------|-------|-------|-------|-------|-------|--------------------|
| 0 | 0 | VR5 | VR4 | VR3 | VR2 | VR1 | VR0 | VOLUME_R (5 : 0) |
| 0 | 1 | VL5 | VL4 | VL3 | VL2 | VL1 | VL0 | VOLUME_L (5 : 0) |
| 1 | 0 | X ⁽¹⁾ | BB4 | BB3 | BB2 | BB1 | BB0 | BASS BOOST (4 : 0) |
| 1 | 1 | X ⁽¹⁾ | TR4 | TR3 | TR2 | TR1 | TR0 | TREBLE (4 : 0) |

Note

1. X = don't care.

MODE: a 2-bit value to program the mode of the sound processing filters of Bass Boost and Treble. There are three modes: flat, min and max.

DE-EMPHASIS: a 1-bit value to enable the digital de-emphasis filter.

Table 8 The flat/min/max switch

| MODE 1 | MODE 0 | FUNCTION |
|--------|--------|----------|
| 0 | 0 | flat |
| 0 | 1 | min |
| 1 | 0 | min |
| 1 | 1 | max |

Table 9 De-emphasis

| DEEM | FUNCTION |
|------|-----------------------|
| 0 | no de-emphasis |
| 1 | de-emphasis, 44.1 kHz |

CHANNEL_MANIP_R and CHANNEL_MANIP_L: both are a 2 bit value to program the right or left channel manipulation.

Table 10 Channel manipulation modes

| CHANNEL_MANIP_L<1 : 0> | CHANNEL_MANIP_R<1 : 0> | L_CHANNEL | R_CHANNEL |
|------------------------|------------------------|----------------------|----------------------|
| 00 | 00 | MUTE | MUTE |
| 00 | 01 | MUTE | R |
| 00 | 10 | MUTE | L |
| 00 | 11 | MUTE | $\frac{1}{2}(L + R)$ |
| 01 | 00 | R | MUTE |
| 01 | 01 | R | R |
| 01 | 10 | R | L |
| 01 | 11 | R | $\frac{1}{2}(L + R)$ |
| 10 | 00 | L | MUTE |
| 10 | 01 | L | R |
| 10 | 10 | L | L |
| 10 | 11 | L | $\frac{1}{2}(L + R)$ |
| 11 | 00 | $\frac{1}{2}(L + R)$ | MUTE |
| 11 | 01 | $\frac{1}{2}(L + R)$ | R |
| 11 | 10 | $\frac{1}{2}(L + R)$ | L |
| 11 | 11 | $\frac{1}{2}(L + R)$ | $\frac{1}{2}(L + R)$ |

Bitstream continuous calibration filter-DAC for CD-ROM audio applications

TDA1388

VOLUME_R: a 6-bit value to program the right channel volume attenuation (VR5 to VR0). The range is 0 dB to $-\infty$ dB in steps of 1 dB.

Table 11 Volume right settings

| VR5 | VR4 | VR3 | VR2 | VR1 | VR0 | VOLUME (dB) |
|-----|-----|-----|-----|-----|-----|-------------|
| 0 | 0 | 0 | 0 | 0 | 0 | 0 |
| 0 | 0 | 0 | 0 | 0 | 1 | 0 |
| 0 | 0 | 0 | 0 | 1 | 0 | -1 |
| 0 | 0 | 0 | 0 | 1 | 1 | -2 |
| ... | ... | ... | ... | ... | ... | ... |
| 1 | 1 | 1 | 0 | 0 | 0 | -55 |
| 1 | 1 | 1 | 0 | 0 | 1 | $-\infty$ |
| 1 | 1 | 1 | 0 | 1 | 0 | $-\infty$ |
| 1 | 1 | 1 | 0 | 1 | 1 | $-\infty$ |
| 1 | 1 | 1 | 1 | 0 | 0 | $-\infty$ |
| 1 | 1 | 1 | 1 | 0 | 1 | $-\infty$ |
| 1 | 1 | 1 | 1 | 1 | 0 | $-\infty$ |
| 1 | 1 | 1 | 1 | 1 | 1 | $-\infty$ |

VOLUME_L: a 6-bit value to program the left channel volume attenuation (VL5 to VL0). The range is 0 dB to $-\infty$ dB in steps of 1 dB.

Table 12 Volume left settings

| VR5 | VR4 | VR3 | VR2 | VR1 | VR0 | VOLUME (dB) |
|-----|-----|-----|-----|-----|-----|-------------|
| 0 | 0 | 0 | 0 | 0 | 0 | 0 |
| 0 | 0 | 0 | 0 | 0 | 1 | 0 |
| 0 | 0 | 0 | 0 | 1 | 0 | -1 |
| 0 | 0 | 0 | 0 | 1 | 1 | -2 |
| ... | ... | ... | ... | ... | ... | ... |
| 1 | 1 | 1 | 0 | 0 | 0 | -55 |
| 1 | 1 | 1 | 0 | 0 | 1 | $-\infty$ |
| 1 | 1 | 1 | 0 | 1 | 0 | $-\infty$ |
| 1 | 1 | 1 | 0 | 1 | 1 | $-\infty$ |
| 1 | 1 | 1 | 1 | 0 | 0 | $-\infty$ |
| 1 | 1 | 1 | 1 | 0 | 1 | $-\infty$ |
| 1 | 1 | 1 | 1 | 1 | 0 | $-\infty$ |
| 1 | 1 | 1 | 1 | 1 | 1 | $-\infty$ |

Bitstream continuous calibration filter-DAC for CD-ROM audio applications

TDA1388

BASS BOOST: a 5-bit value to program the bass boost setting. The used set depends on the MODE bits.

Table 13 Bass boost settings

| BB4 | BB3 | BB2 | BB1 | BB0 | BASS BOOST | | |
|-----|-----|-----|-----|-----|---------------|--------------|--------------|
| | | | | | FLAT SET (dB) | MIN SET (dB) | MAX SET (dB) |
| 0 | 0 | 0 | 0 | 0 | 0 | 0 | 0 |
| 0 | 0 | 0 | 0 | 1 | 0 | 0 | 0 |
| 0 | 0 | 0 | 1 | 0 | 0 | 2 | 2 |
| 0 | 0 | 0 | 1 | 1 | 0 | 4 | 4 |
| 0 | 0 | 1 | 0 | 0 | 0 | 6 | 6 |
| 0 | 0 | 1 | 0 | 1 | 0 | 8 | 8 |
| 0 | 0 | 1 | 1 | 1 | 0 | 10 | 10 |
| 0 | 0 | 1 | 1 | 0 | 0 | 12 | 12 |
| 0 | 1 | 0 | 0 | 1 | 0 | 14 | 14 |
| 0 | 1 | 0 | 0 | 0 | 0 | 16 | 16 |
| 0 | 1 | 0 | 1 | 1 | 0 | 18 | 18 |
| 0 | 1 | 0 | 1 | 0 | 0 | 18 | 20 |
| 0 | 1 | 1 | 0 | 1 | 0 | 18 | 22 |
| 0 | 1 | 1 | 0 | 0 | 0 | 18 | 24 |
| 0 | 1 | 1 | 1 | 1 | 0 | 18 | 24 |
| 0 | 1 | 1 | 1 | 0 | 0 | 18 | 24 |
| 1 | 0 | 0 | 0 | 0 | 0 | 18 | 24 |
| 1 | 0 | 0 | 0 | 1 | 0 | 18 | 24 |
| 1 | 0 | 0 | 1 | 0 | 0 | 18 | 24 |
| 1 | 0 | 0 | 1 | 1 | 0 | 18 | 24 |
| 1 | 0 | 1 | 0 | 0 | 0 | 18 | 24 |
| 1 | 0 | 1 | 0 | 1 | 0 | 18 | 24 |
| 1 | 0 | 1 | 1 | 1 | 0 | 18 | 24 |
| 1 | 0 | 1 | 1 | 0 | 0 | 18 | 24 |
| 1 | 1 | 0 | 0 | 1 | 0 | 18 | 24 |
| 1 | 1 | 0 | 0 | 0 | 0 | 18 | 24 |
| 1 | 1 | 0 | 1 | 1 | 0 | 18 | 24 |
| 1 | 1 | 0 | 1 | 0 | 0 | 18 | 24 |
| : | : | : | : | : | : | : | : |
| 1 | 1 | 1 | 1 | 0 | 0 | 18 | 24 |

Bitstream continuous calibration filter-DAC for CD-ROM audio applications

TDA1388

TREBLE: a 5-bit value to program the treble setting. The used set depends on the MODE bits.

Table 14 Treble settings

| TR4 | TR3 | TR2 | TR1 | TR0 | TREBLE | | |
|-----|-----|-----|-----|-----|---------------|--------------|--------------|
| | | | | | FLAT SET (dB) | MIN SET (dB) | MAX SET (dB) |
| 0 | 0 | 0 | 0 | 0 | 0 | 0 | 0 |
| 0 | 0 | 0 | 0 | 1 | 0 | 0 | 0 |
| 0 | 0 | 0 | 1 | 0 | 0 | 2 | 2 |
| 0 | 0 | 0 | 1 | 1 | 0 | 2 | 2 |
| 0 | 0 | 1 | 0 | 0 | 0 | 4 | 4 |
| 0 | 0 | 1 | 0 | 1 | 0 | 4 | 4 |
| 0 | 0 | 1 | 1 | 1 | 0 | 6 | 6 |
| 0 | 0 | 1 | 1 | 0 | 0 | 6 | 6 |
| 0 | 1 | 0 | 0 | 1 | 0 | 6 | 6 |
| 0 | 1 | 0 | 0 | 0 | 0 | 6 | 6 |
| 0 | 1 | 0 | 1 | 1 | 0 | 6 | 6 |
| 0 | 1 | 0 | 1 | 0 | 0 | 6 | 6 |
| 0 | 1 | 1 | 0 | 1 | 0 | 6 | 6 |
| 0 | 1 | 1 | 0 | 0 | 0 | 6 | 6 |
| 0 | 1 | 1 | 1 | 1 | 0 | 6 | 6 |
| 0 | 1 | 1 | 1 | 0 | 0 | 6 | 6 |
| : | : | : | : | : | : | : | : |
| 1 | 1 | 1 | 1 | 0 | 0 | 6 | 6 |

Flat/min/max setting selection

In the TDA1388 has three setting for the digital sound features bass boost and treble. The possible settings are called 'flat', 'min' and 'max'. The flat setting has no influence on the audio signal, the minimum setting has a small influence on the audio signal and the maximum setting has a large influence on the audio signal. In the static-pin mode, the flat setting is used for the bass boost and treble filters. In the microcontroller mode, all three settings can be controlled by a register.

Channel manipulation modes

In the TDA1388 there is a channel manipulation function implemented. This function has a fixed value in the static-pin mode, the left signal on the left channel and the right signal on the right channel. In the microcontroller mode several options are possible.

The different modes are as follows:

- Normal stereo output
- Left/right reverse output
- Mono left/right output: $\frac{1}{2}(L + R)$
- Output muting with soft mute.

De-emphasis

De-emphasis is controlled by an external pin in the static-pin mode and by a register in the microcontroller mode. The digital de-emphasis filter is dimensioned to produce the de-emphasis frequency characteristics for the sample rate 44.1 kHz. With its 18-bit dynamic range, the digital de-emphasis filter of the TDA1388 is a convenient and component saving alternative to analog de-emphasis. De-emphasis is synchronized to the sample clock, so that operation always takes place on complete samples.

Bitstream continuous calibration filter-DAC for CD-ROM audio applications

TDA1388

Volume control

The volume of the left and right channels are controlled by a fixed value (0 dB) in the static-pin mode and by separate registers in the microcontroller mode. In the microcontroller mode the values of both channels can vary, independent of each other, from 0 dB to $-\infty$ dB.

Since there is no headroom included into the sound control section, the volume control precedes the sound control. Full volume and neutral setting (flat) of the sound control results in full-scale output. Any tone boost will directly cause clipping, which can be avoided by reduction of the volume setting.

Bass boost

A strong bass boost effect, which is useful in compensating for poor response of portable headphone sets, is implemented digitally in the TDA1388 and can be controlled in the microcontroller mode. In the static-pin mode, the flat setting is fixed. In the microcontroller mode, valid settings range from flat (no influence on audio) to +18 dB with step sizes of 2 dB in minimum and to +24 dB with step sizes of 2 dB in maximum. The programmable bass boost filter is a 2nd-order shelving type with a fixed corner frequency of 130 Hz for the minimum setting and a fixed corner frequency of 230 Hz for the maximum setting and has a Butterworth characteristic. Because of the exceptional amount of programmable gain, bass boost should be used with adequate prior attenuation, using the volume control.

Treble

A treble effect is implemented digitally in the TDA1388 and can be controlled in the microcontroller mode. In the static-pin mode, the flat setting is fixed. In the microcontroller mode, valid settings range from flat (no influence on audio) to +6 dB with step sizes of 2 dB in minimum and to +6 dB with step sizes of 2 dB in maximum. The programmable treble filter is a 1st-order shelving type with a fixed corner frequency of 2.8 kHz for the minimum setting and a fixed corner frequency of 5.0 kHz for the maximum setting. Because of the exceptional amount of programmable gain, treble should be used with adequate prior attenuation, using the volume control.

Soft mute

Soft mute is controlled by external pins, for each channel one, in the static-pin mode and by the channel manipulation modes of left or right in the microcontroller mode.

When the mute is active for a channel, the value of the sample is decreased smoothly to zero following a raised cosine curve. 32 coefficients are used to step down the value of the data, each one being used 32 times before stepping on to the next. This amounts to a mute transition of 23 ms at $f_s = 44.1$ kHz. When the mute is released, the samples are returned to the full level again following a raised cosine curve with the same coefficients being used in the reverse order. The mute, on the left or right channel, is synchronized to the sample clock, so that operation always takes place on complete samples.

Oversampling and noise shaper

The digital filter is four times oversampling filter. It consists of two sections which each increase the sample rate by 2. The 2nd-order noise shaper operates at $64f_s$. It shifts in-band quantization noise to frequencies well above the audio band. This noise shaping technique used in combination with a sign-magnitude coding enables high signal-to-noise ratios to be achieved. The noise shaper outputs a 5-bit PDM bitstream signal to the DAC.

Continuous calibration DAC

The dual 5-bit DAC uses the continuous calibration technique. This method, based on charge storage, involves exact duplication of a single reference current source. In the TDA1388, 32 such current sources plus 1 spare source are continuously calibrated. The spare source is included to allow continuous convertor operation. The DAC receives a 5-bit data bitstream from the noise shaper. This data is converted so that no current is switched to the output during digital silence (input 00000H). In this way very high signal-to-noise performance is achieved.

Stereo line driver

High precision, low-noise amplifiers together with the internal conversion resistor R_{CONV1} and R_{CONV2} convert the converter output current to a voltage capable of driving a headphone. The voltage is available at V_{OL} and V_{OR} (pins 4 and 25).

Stereo headphone driver

High precision, low-noise amplifiers are capable of driving a headphone load. The voltage is available at $HPOUTL$ and $HPOUTR$ (pins 2 and 27).

Bitstream continuous calibration filter-DAC for CD-ROM audio applications

TDA1388

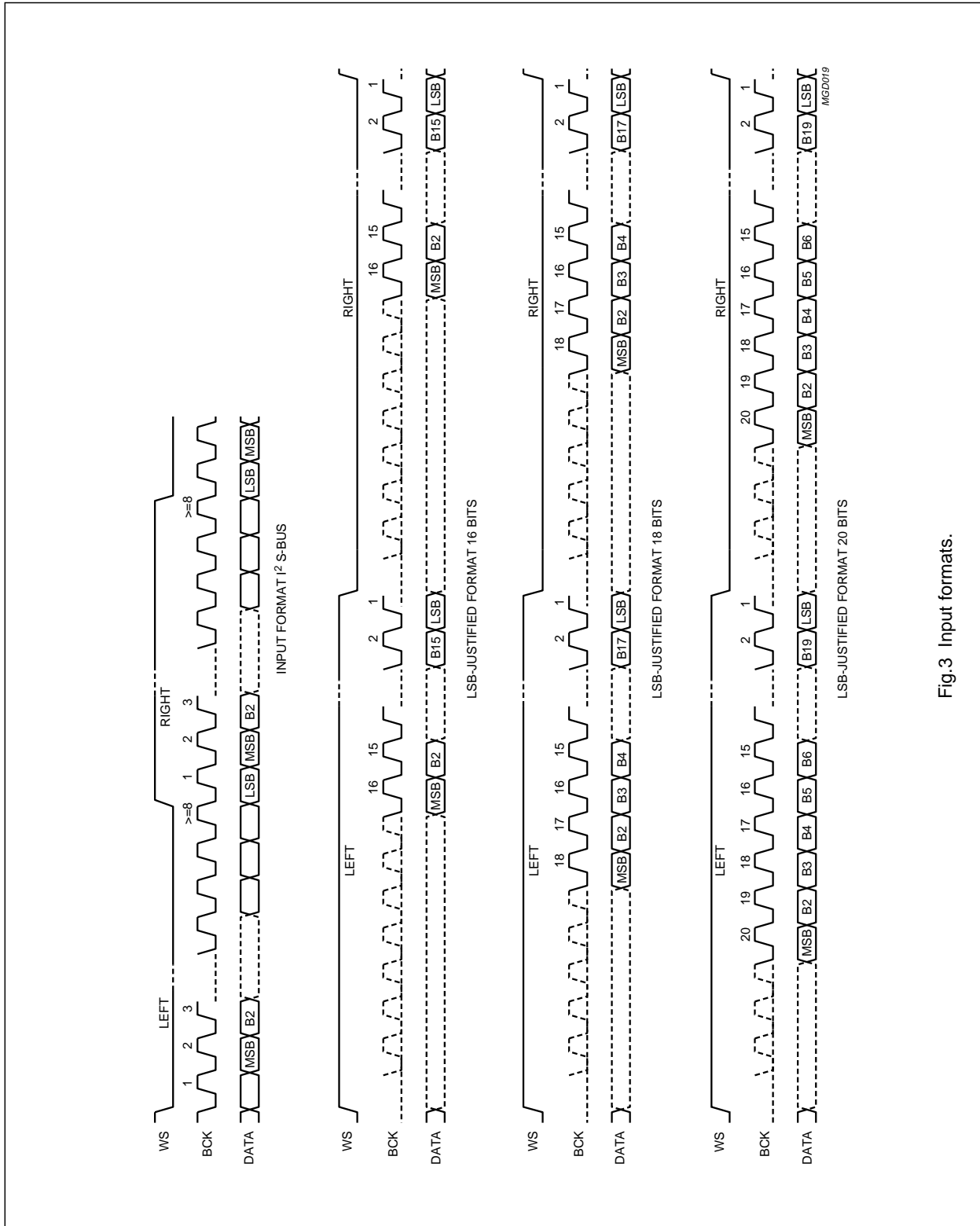

Fig.3 Input formats.

Bitstream continuous calibration filter-DAC
for CD-ROM audio applications

TDA1388

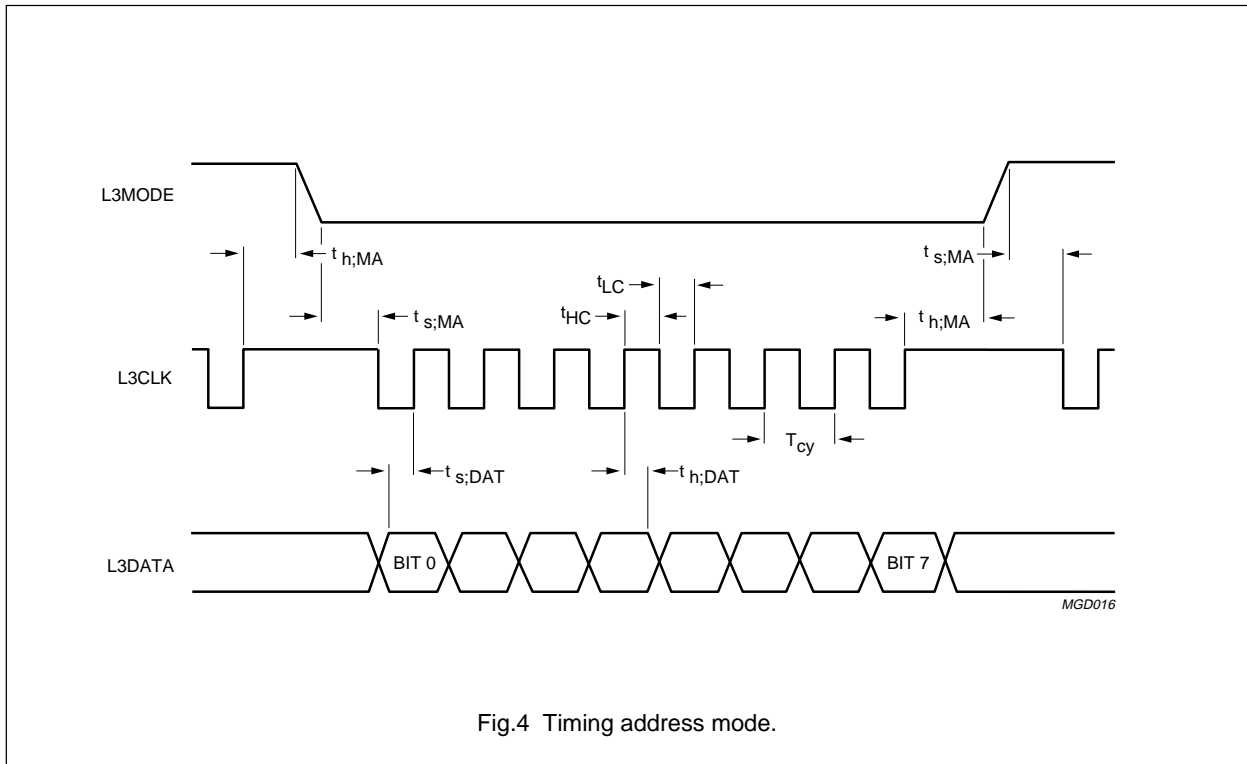

Fig.4 Timing address mode.

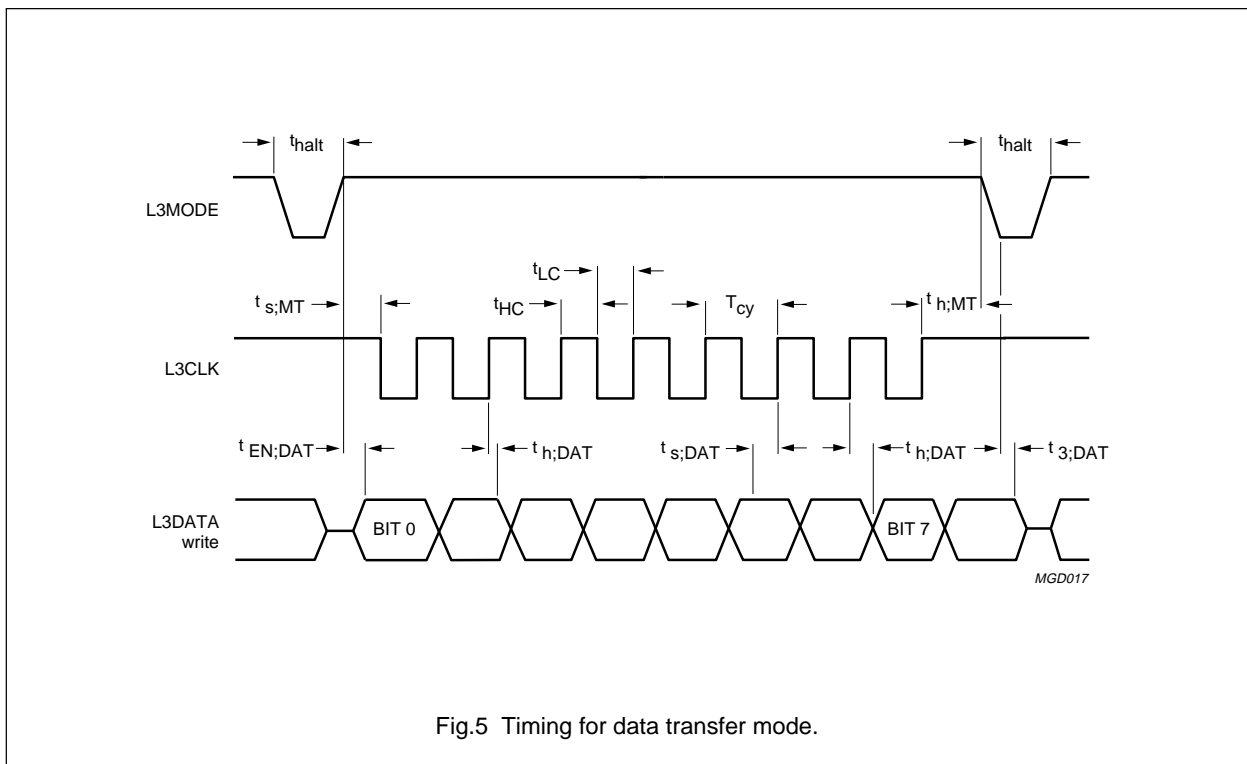
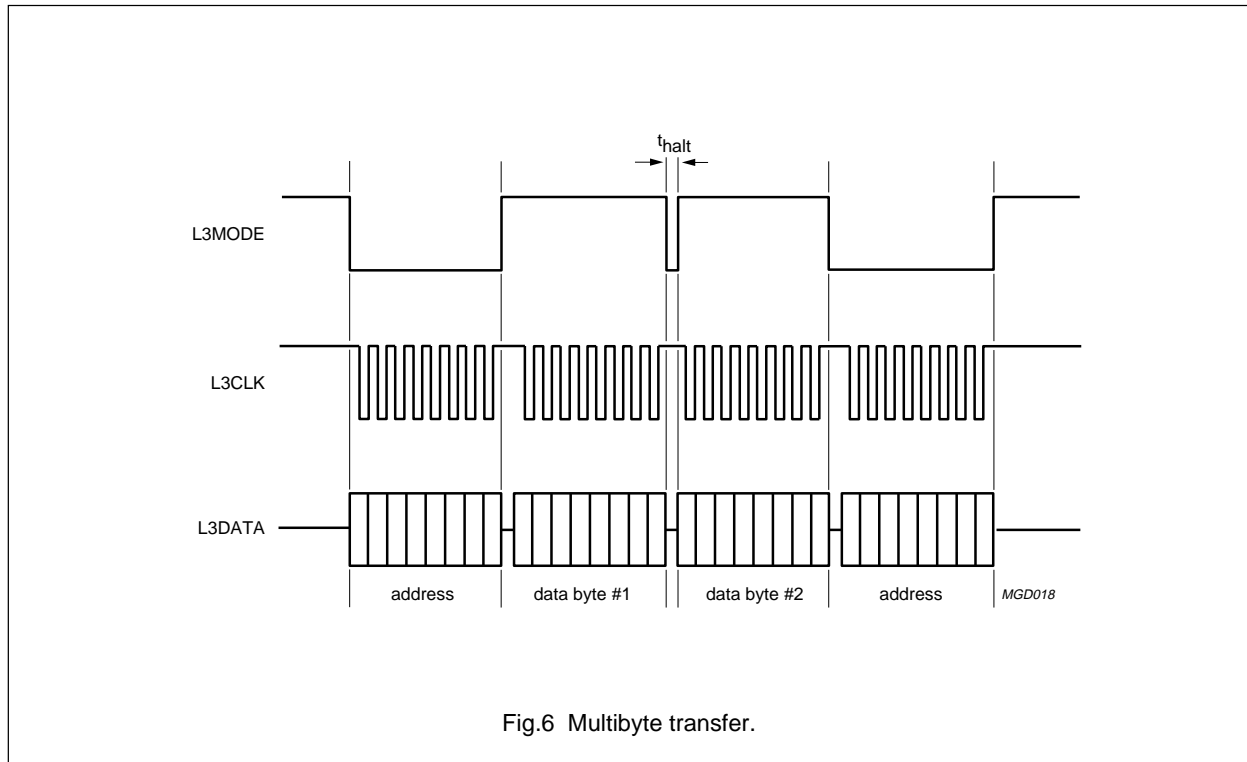

Fig.5 Timing for data transfer mode.

Bitstream continuous calibration filter-DAC for CD-ROM audio applications

TDA1388



LIMITING VALUES

In accordance with the Absolute Maximum Rating System (IEC 134). All voltages referenced to ground, $V_{DD} = V_{DDA} = V_{DDO} = 5\text{ V}$; $T_{amb} = 25\text{ }^{\circ}\text{C}$, unless otherwise specified.

| SYMBOL | PARAMETER | CONDITIONS | MIN. | MAX. | UNIT |
|-----------------|-------------------------------|------------|-------|-------|--------------------|
| V_{DD} | supply voltage | note 1 | – | 7.0 | V |
| $T_{xtal(max)}$ | maximum crystal temperature | | – | 150 | $^{\circ}\text{C}$ |
| T_{stg} | storage temperature | | –65 | +125 | $^{\circ}\text{C}$ |
| T_{amb} | operating ambient temperature | | –20 | +70 | $^{\circ}\text{C}$ |
| V_{es} | electrostatic handling | note 2 | –3000 | +3000 | V |
| | | note 3 | –300 | +300 | V |

Notes

- All V_{DD} and V_{SS} connections must be made to the same power supply.
- Equivalent to discharging a 100 pF capacitor via a 1.5 k Ω series resistor.
- Equivalent to discharging a 200 pF capacitor via a 2.5 μH series inductor.

Bitstream continuous calibration filter-DAC for CD-ROM audio applications

TDA1388

THERMAL CHARACTERISTICS

| SYMBOL | PARAMETER | VALUE | UNIT |
|---------------|---|-------|------|
| $R_{th\ j-a}$ | thermal resistance from junction to ambient in free air | | |
| | SOP28 | 60 | K/W |
| | SSOP28 | 80 | K/W |

DC CHARACTERISTICS

$V_{DDD} = V_{DDA} = V_{DDO} = 5\text{ V}$; $T_{amb} = 25\text{ }^{\circ}\text{C}$; $R_L = 5\text{ k}\Omega$; all voltages referenced to ground (pins 1, 13, 21 and 23); unless otherwise specified.

| SYMBOL | PARAMETER | CONDITIONS | MIN. | TYP. | MAX. | UNIT |
|---------------------------|--|--|---------------|--------------|-----------------|------------------|
| V_{DDD} | digital supply voltage | note 1 | 4.5 | 5.0 | 5.5 | V |
| V_{DDA} | analog supply voltage | note 1 | 4.5 | 5.0 | 5.5 | V |
| V_{DDO} | operational amplifier supply voltage | note 1 | 4.5 | 5.0 | 5.5 | V |
| I_{DDD} | digital supply current | at digital silence | – | 7.0 | – | mA |
| I_{DDA} | analog supply current | at digital silence | – | 5.0 | – | mA |
| I_{DDO} | operational amplifier supply current | at digital silence | – | 10 | – | mA |
| P_{tot} | total power dissipation | note 2 | – | 110 | – | mW |
| Digital input pins | | | | | | |
| V_{IH} | HIGH level input voltage | | $0.7V_{DDD}$ | – | $V_{DDD} + 0.5$ | V |
| V_{IL} | LOW level input voltage | | – | – | $0.3V_{DDD}$ | V |
| $ I_{Ll} $ | input leakage current | | – | – | 10 | μA |
| C_{in} | input capacitance | | – | – | 10 | pF |
| Analog audio pins | | | | | | |
| V_{ref} | reference voltage | with respect to V_{SSA} | $0.45V_{DDA}$ | $0.5V_{DDA}$ | $0.55V_{DDA}$ | V |
| $R_{out(ref)}$ | output reference resistance | | – | 3 | – | $\text{k}\Omega$ |
| R_{CONV} | current-to-voltage conversion resistor | | – | 2.7 | – | $\text{k}\Omega$ |
| $I_{o(max)}$ | maximum output current | $(\text{THD+N})/S < 0.1\%$ $R_L = 32\ \Omega$ | – | 88 | – | mA |
| | | $(\text{THD+N})/S < 0.1\%$ $R_L = 16\ \Omega$ | – | 44 | – | mA |
| C_L | output load capacitance | note 3 | – | – | 50 | pF |

Notes

- All power supply pins (V_{DD} and V_{SS}) must be connected to the same external power supply unit.
- No operational amplifier load resistor.
- Load capacitance larger than 50 pF, a 22 μH inductor in parallel with a 270 Ω resistor must be inserted between the load and the operational amplifier output (line output only).

Bitstream continuous calibration filter-DAC for CD-ROM audio applications

TDA1388

AC CHARACTERISTICS (ANALOG)

$V_{DDD} = V_{DDA} = V_{DDO} = 5\text{ V}$; $f_i = 1\text{ kHz}$; $T_{\text{amb}} = 25\text{ °C}$; $R_L = 5\text{ k}\Omega$ all voltages referenced to ground (pins 1, 13, 21 and 23); unless otherwise specified.

| SYMBOL | PARAMETER | CONDITIONS | MIN. | TYP. | MAX. | UNIT |
|--|---|--|------|-------|-------|------|
| RES | resolution | | – | – | 18 | bits |
| $V_{FS(\text{rms})}$ | output voltage swing (RMS value) | note 1 | 0.9 | 1.0 | 1.1 | V |
| $V_{DC(\text{os})}$ | output voltage DC offset with respect to reference voltage level V_{ref} | | – | 20 | – | mV |
| SVRR | supply voltage ripple rejection V_{DDA} and V_{DDO} | $f_{\text{ripple}} = 1\text{ kHz}$; $V_{\text{ripple}(p-p)} = 100\text{ mV}$; $C_{\text{pin}} = 10\text{ }\mu\text{F}$ | – | 40 | – | dB |
| $ \Delta V_o $ | unbalance between the 2 DAC voltage outputs | maximum volume | – | 0.1 | – | dB |
| α_{ct} | crosstalk between the 2 DAC voltage outputs for line outputs | $R_L = 5\text{ k}\Omega$, note 2 | – | 90 | – | dB |
| | | $R_L = 16\text{ }\Omega$, note 2 | – | 60 | – | dB |
| | | $R_L = 32\text{ }\Omega$, note 2 | – | 65 | – | dB |
| (THD+N)/S | total harmonic distortion plus noise as a function of signal for the line output | 0 dB signal; $R_L = 5\text{ k}\Omega$ | – | –85 | –80 | dB |
| | | –60 dB signal; $R_L = 5\text{ k}\Omega$ | – | 0.006 | 0.013 | % |
| | | –60 dB signal; $R_L = 5\text{ k}\Omega$ | – | –35 | –30 | dBA |
| | total harmonic distortion plus noise as a function of signal for the headphone output | 0 dB signal; $R_L = 16\text{ }\Omega$ | – | 1.8 | 3.2 | % |
| | | 0 dB signal; $R_L = 16\text{ }\Omega$ | – | –65 | – | dB |
| | | 0 dB signal; $R_L = 32\text{ }\Omega$ | – | 0.056 | – | % |
| | | 0 dB signal; $R_L = 32\text{ }\Omega$ | – | –70 | – | dB |
| | | –60 dB signal; $R_L = 16\text{ }\Omega$ or $R_L = 32\text{ }\Omega$ | – | 0.032 | – | % |
| –60 dB signal; $R_L = 16\text{ }\Omega$ or $R_L = 32\text{ }\Omega$ | – | –35 | –30 | dBA | | |
| –60 dB signal; $R_L = 16\text{ }\Omega$ or $R_L = 32\text{ }\Omega$ | – | 1.8 | 3.2 | % | | |
| S/N | signal-to-noise ratio at bipolar zero | A weighting; at code 00000H | 90 | 95 | – | dBA |

Notes

1. Proportional to V_{DDA} .
2. One output digital silence, the other maximum volume.

Bitstream continuous calibration filter-DAC for CD-ROM audio applications

TDA1388

AC CHARACTERISTICS (DIGITAL)

$V_{DD3} = V_{DDA} = V_{DDO} = 4.5$ to 5.5 V; $T_{amb} = -20$ to $+70$ °C; $R_L = 5$ k Ω ; all voltages referenced to ground (pins 1, 13, 21 and 23); unless otherwise specified.

| SYMBOL | PARAMETER | CONDITIONS | MIN. | TYP. | MAX. | UNIT |
|---|----------------------------------|--------------------|-------|---------|--------|------|
| T_{cy} | clock cycle | $f_{sys} = 256f_s$ | 81.3 | 88.6 | 122 | ns |
| | | $f_{sys} = 384f_s$ | 54.2 | 59.1 | 81.3 | ns |
| t_{CWL} | f_{sys} LOW level pulse width | | 22 | – | – | ns |
| t_{CWH} | f_{sys} HIGH level pulse width | | 22 | – | – | ns |
| Serial input data timing (see Fig.7) | | | | | | |
| BR | clock input = data input rate | $f_{sys} = 256f_s$ | – | $64f_s$ | – | |
| | | $f_{sys} = 384f_s$ | – | $48f_s$ | – | |
| f_{sys} | system clock frequency | | 8.192 | – | 18.432 | MHz |
| f_{WS} | word selection input frequency | | – | 44.1 | 48 | kHz |
| t_r | rise time | | – | – | 20 | ns |
| t_f | fall time | | – | – | 20 | ns |
| $t_{BCK(H)}$ | bit clock HIGH time | | 55 | – | – | ns |
| $t_{BCK(L)}$ | bit clock LOW time | | 55 | – | – | ns |
| $t_{s,DAT}$ | data set-up time | | 10 | – | – | ns |
| $t_{h,DAT}$ | data hold time | | 20 | – | – | ns |
| $t_{s,WS}$ | word selection set-up time | | 20 | – | – | ns |
| $t_{h,WS}$ | word selection hold time | | 10 | – | – | ns |

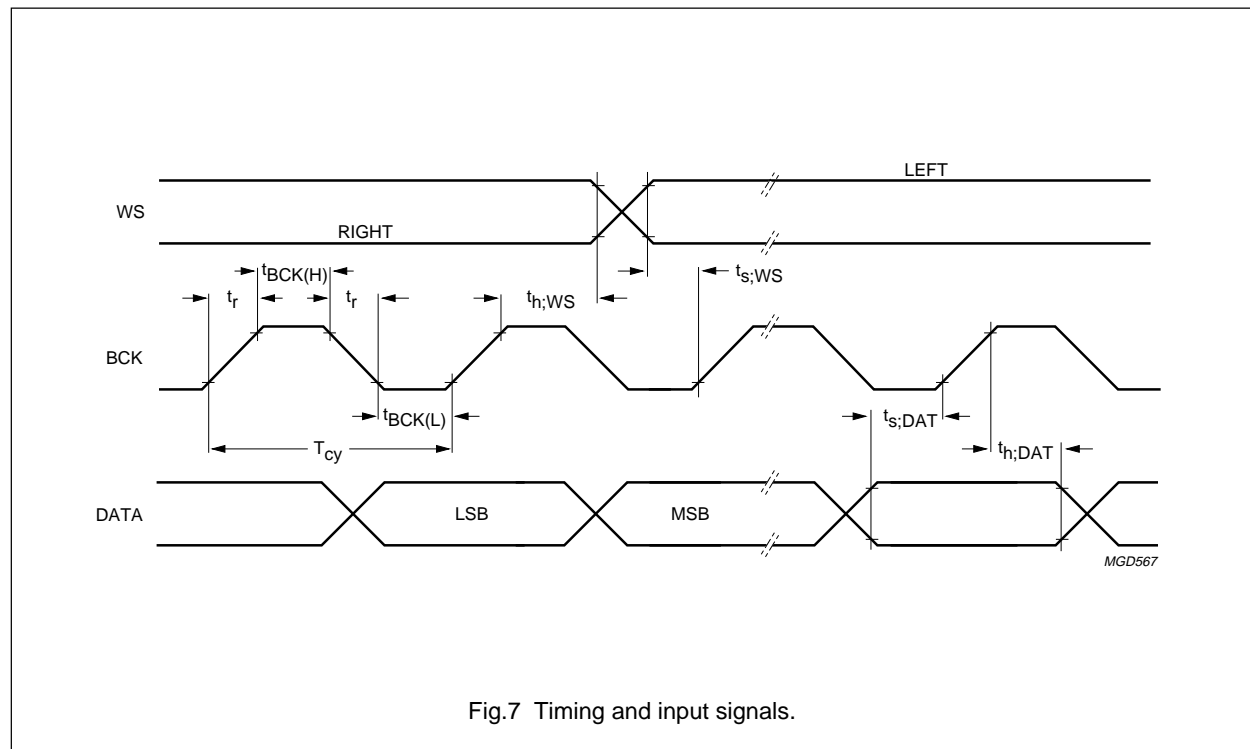
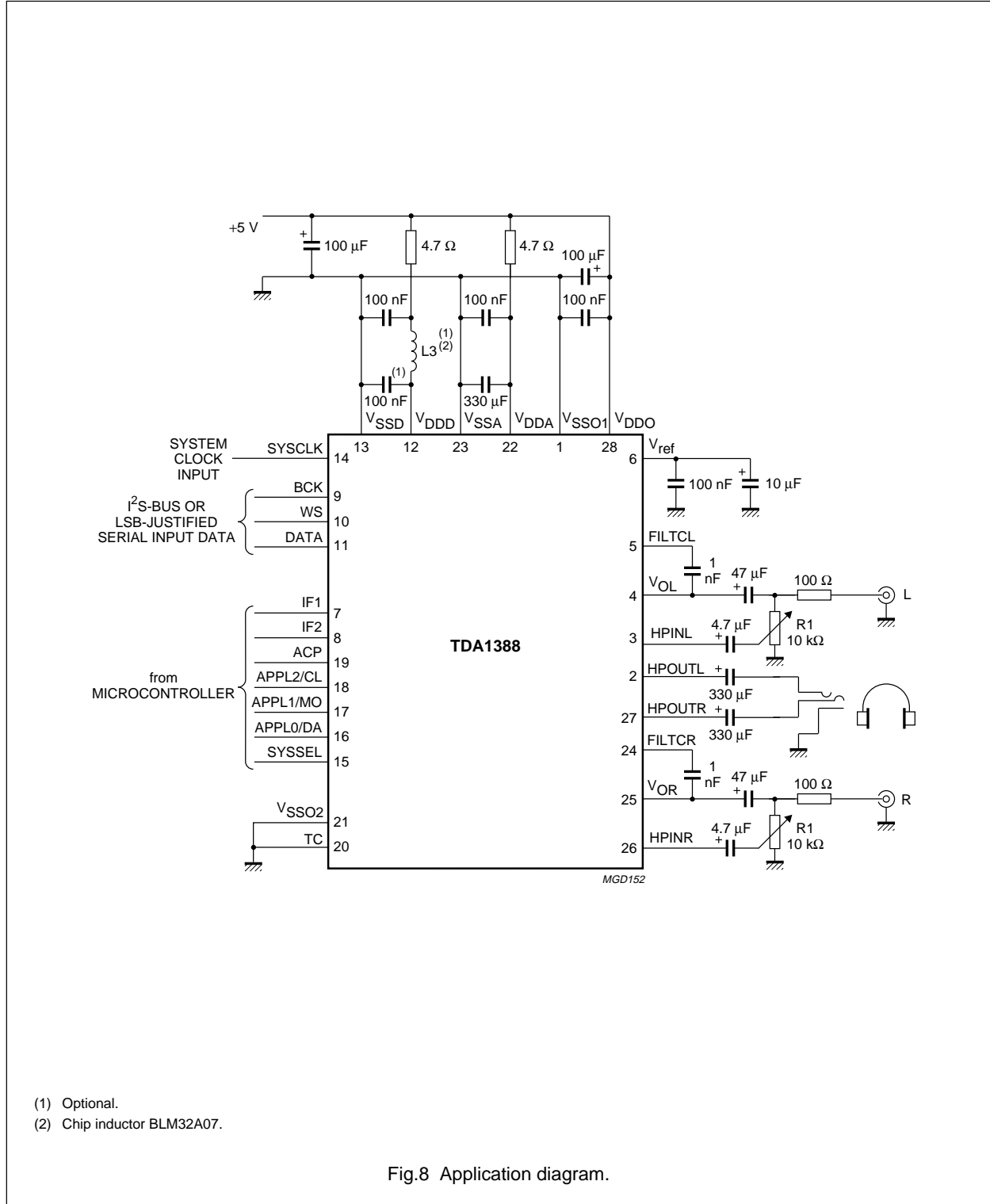

Fig.7 Timing and input signals.

Bitstream continuous calibration filter-DAC for CD-ROM audio applications

TDA1388

TEST AND APPLICATION INFORMATION



- (1) Optional.
- (2) Chip inductor BLM32A07.

Fig.8 Application diagram.

Bitstream continuous calibration filter-DAC for CD-ROM audio applications

TDA1388

PACKAGE OUTLINES

SO28: plastic small outline package; 28 leads; body width 7.5 mm

SOT136-1

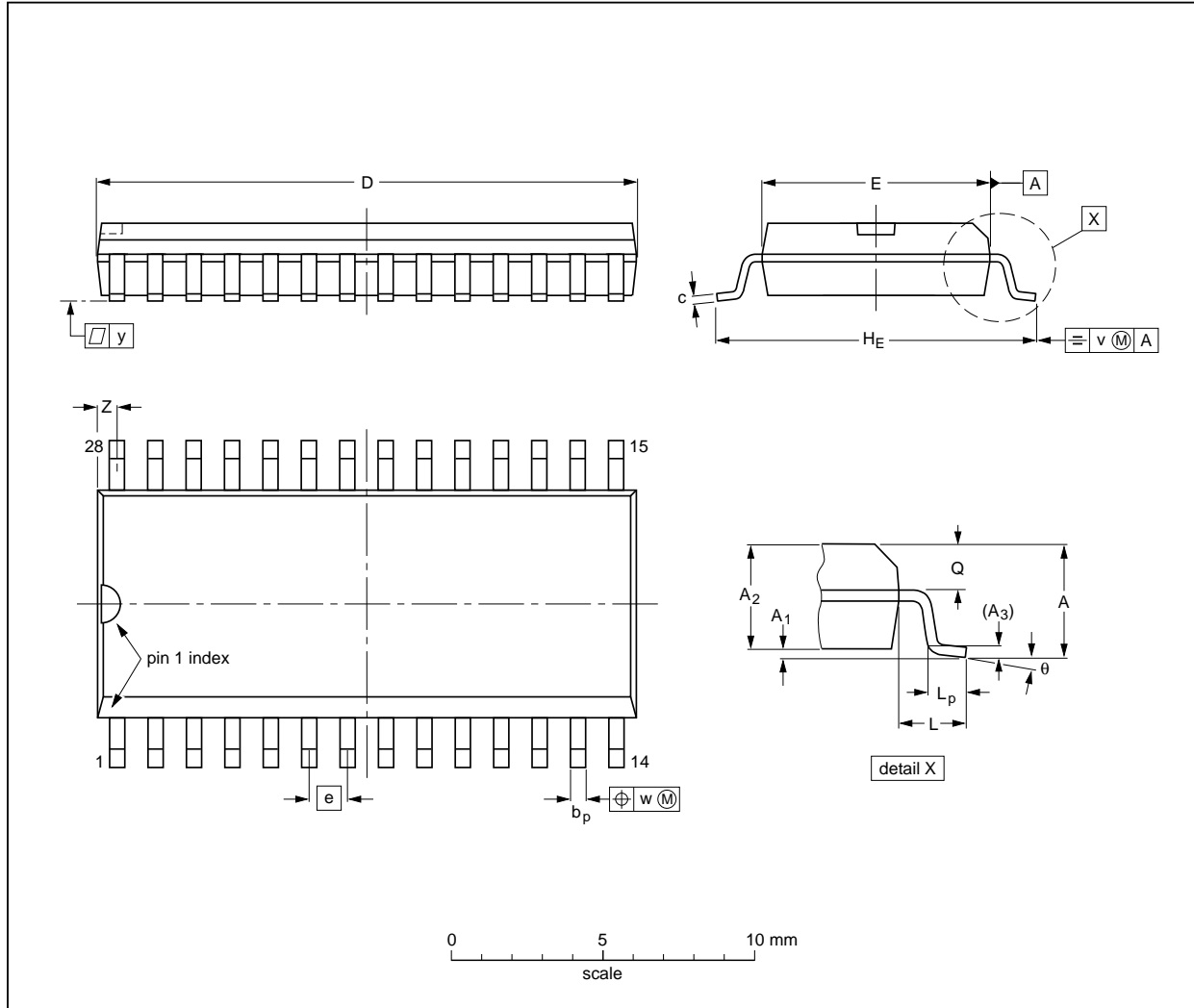

DIMENSIONS (inch dimensions are derived from the original mm dimensions)

| UNIT | A max. | A ₁ | A ₂ | A ₃ | b _p | c | D ⁽¹⁾ | E ⁽¹⁾ | e | H _E | L | L _p | Q | v | w | y | z ⁽¹⁾ | θ |
|--------|--------|----------------|----------------|----------------|----------------|----------------|------------------|------------------|-------|----------------|-------|----------------|----------------|------|------|-------|------------------|----------|
| mm | 2.65 | 0.30 0.10 | 2.45 2.25 | 0.25 | 0.49 0.36 | 0.32 0.23 | 18.1 17.7 | 7.6 7.4 | 1.27 | 10.65 10.00 | 1.4 | 1.1 0.4 | 1.1 1.0 | 0.25 | 0.25 | 0.1 | 0.9 0.4 | 8° 0° |
| inches | 0.10 | 0.012 0.004 | 0.096 0.089 | 0.01 | 0.019 0.014 | 0.013 0.009 | 0.71 0.69 | 0.30 0.29 | 0.050 | 0.42 0.39 | 0.055 | 0.043 0.016 | 0.043 0.039 | 0.01 | 0.01 | 0.004 | 0.035 0.016 | |

Note

1. Plastic or metal protrusions of 0.15 mm maximum per side are not included.

| OUTLINE VERSION | REFERENCES | | | EUROPEAN PROJECTION | ISSUE DATE |
|-----------------|------------|----------|------|---------------------|----------------------|
| | IEC | JEDEC | EIAJ | | |
| SOT136-1 | 075E06 | MS-013AE | | | 91-08-13 95-01-24 |

Bitstream continuous calibration filter-DAC
for CD-ROM audio applications

TDA1388

SSOP28: plastic shrink small outline package; 28 leads; body width 5.3 mm

SOT341-1

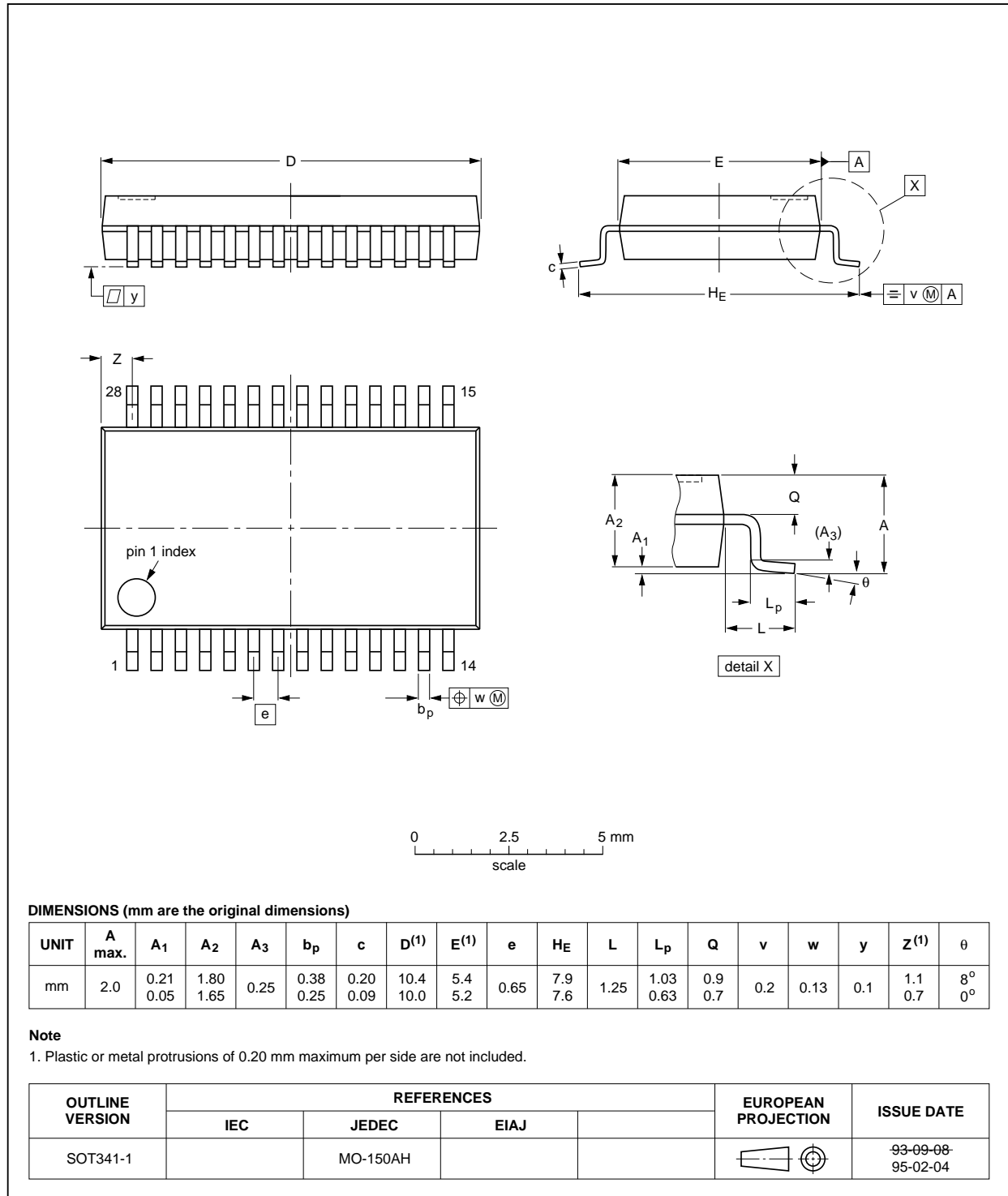

Bitstream continuous calibration filter-DAC for CD-ROM audio applications

TDA1388

SOLDERING

Introduction

There is no soldering method that is ideal for all IC packages. Wave soldering is often preferred when through-hole and surface mounted components are mixed on one printed-circuit board. However, wave soldering is not always suitable for surface mounted ICs, or for printed-circuits with high population densities. In these situations reflow soldering is often used.

This text gives a very brief insight to a complex technology. A more in-depth account of soldering ICs can be found in our *"IC Package Databook"* (order code 9398 652 90011).

Reflow soldering

Reflow soldering techniques are suitable for all SO and SSOP packages.

Reflow soldering requires solder paste (a suspension of fine solder particles, flux and binding agent) to be applied to the printed-circuit board by screen printing, stencilling or pressure-syringe dispensing before package placement.

Several techniques exist for reflowing; for example, thermal conduction by heated belt. Dwell times vary between 50 and 300 seconds depending on heating method. Typical reflow temperatures range from 215 to 250 °C.

Preheating is necessary to dry the paste and evaporate the binding agent. Preheating duration: 45 minutes at 45 °C.

Wave soldering

SO

Wave soldering techniques can be used for all SO packages if the following conditions are observed:

- A double-wave (a turbulent wave with high upward pressure followed by a smooth laminar wave) soldering technique should be used.
- The longitudinal axis of the package footprint must be parallel to the solder flow.
- The package footprint must incorporate solder thieves at the downstream end.

SSOP

Wave soldering is **not** recommended for SSOP packages. This is because of the likelihood of solder bridging due to closely-spaced leads and the possibility of incomplete solder penetration in multi-lead devices.

If wave soldering cannot be avoided, the following conditions must be observed:

- **A double-wave (a turbulent wave with high upward pressure followed by a smooth laminar wave) soldering technique should be used.**
- **The longitudinal axis of the package footprint must be parallel to the solder flow and must incorporate solder thieves at the downstream end.**

Even with these conditions, only consider wave soldering SSOP packages that have a body width of 4.4 mm, that is SSOP16 (SOT369-1) or SSOP20 (SOT266-1).

METHOD (SO AND SSOP)

During placement and before soldering, the package must be fixed with a droplet of adhesive. The adhesive can be applied by screen printing, pin transfer or syringe dispensing. The package can be soldered after the adhesive is cured.

Maximum permissible solder temperature is 260 °C, and maximum duration of package immersion in solder is 10 seconds, if cooled to less than 150 °C within 6 seconds. Typical dwell time is 4 seconds at 250 °C.

A mildly-activated flux will eliminate the need for removal of corrosive residues in most applications.

Repairing soldered joints

Fix the component by first soldering two diagonally-opposite end leads. Use only a low voltage soldering iron (less than 24 V) applied to the flat part of the lead. Contact time must be limited to 10 seconds at up to 300 °C. When using a dedicated tool, all other leads can be soldered in one operation within 2 to 5 seconds between 270 and 320 °C.

Bitstream continuous calibration filter-DAC for CD-ROM audio applications

TDA1388

DEFINITIONS

| Data sheet status | |
|---|---|
| Objective specification | This data sheet contains target or goal specifications for product development. |
| Preliminary specification | This data sheet contains preliminary data; supplementary data may be published later. |
| Product specification | This data sheet contains final product specifications. |
| Limiting values | |
| Limiting values given are in accordance with the Absolute Maximum Rating System (IEC 134). Stress above one or more of the limiting values may cause permanent damage to the device. These are stress ratings only and operation of the device at these or at any other conditions above those given in the Characteristics sections of the specification is not implied. Exposure to limiting values for extended periods may affect device reliability. | |
| Application information | |
| Where application information is given, it is advisory and does not form part of the specification. | |

LIFE SUPPORT APPLICATIONS

These products are not designed for use in life support appliances, devices, or systems where malfunction of these products can reasonably be expected to result in personal injury. Philips customers using or selling these products for use in such applications do so at their own risk and agree to fully indemnify Philips for any damages resulting from such improper use or sale.

Philips Semiconductors – a worldwide company

Argentina: see South America

Australia: 34 Waterloo Road, NORTH RYDE, NSW 2113,
Tel. +61 2 9805 4455, Fax. +61 2 9805 4466

Austria: Computerstr. 6, A-1101 WIEN, P.O. Box 213,
Tel. +43 1 60 101, Fax. +43 1 60 101 1210

Belarus: Hotel Minsk Business Center, Bld. 3, r. 1211, Volodarski Str. 6,
220050 MINSK, Tel. +375 172 200 733, Fax. +375 172 200 773

Belgium: see The Netherlands

Brazil: see South America

Bulgaria: Philips Bulgaria Ltd., Energoproject, 15th floor,
51 James Bourchier Blvd., 1407 SOFIA,
Tel. +359 2 689 211, Fax. +359 2 689 102

Canada: PHILIPS SEMICONDUCTORS/COMPONENTS,
Tel. +1 800 234 7381, Fax. +1 708 296 8556

China/Hong Kong: 501 Hong Kong Industrial Technology Centre,
72 Tat Chee Avenue, Kowloon Tong, HONG KONG,
Tel. +852 2319 7888, Fax. +852 2319 7700

Colombia: see South America

Czech Republic: see Austria

Denmark: Prags Boulevard 80, PB 1919, DK-2300 COPENHAGEN S,
Tel. +45 32 88 2636, Fax. +45 31 57 1949

Finland: Sinikalliontie 3, FIN-02630 ESPOO,
Tel. +358 615 800, Fax. +358 615 80920

France: 4 Rue du Port-aux-Vins, BP317, 92156 SURESNES Cedex,
Tel. +33 1 40 99 6161, Fax. +33 1 40 99 6427

Germany: Hammerbrookstraße 69, D-20097 HAMBURG,
Tel. +49 40 23 52 60, Fax. +49 40 23 536 300

Greece: No. 15, 25th March Street, GR 17778 TAVROS,
Tel. +30 1 4894 339/911, Fax. +30 1 4814 240

Hungary: see Austria

India: Philips INDIA Ltd, Shivsagar Estate, A Block, Dr. Annie Besant Rd.
Worli, MUMBAI 400 018, Tel. +91 22 4938 541, Fax. +91 22 4938 722

Indonesia: see Singapore

Ireland: Newstead, Clonskeagh, DUBLIN 14,
Tel. +353 1 7640 000, Fax. +353 1 7640 200

Israel: RAPAC Electronics, 7 Kehilat Saloniki St, TEL AVIV 61180,
Tel. +972 3 645 0444, Fax. +972 3 648 1007

Italy: PHILIPS SEMICONDUCTORS, Piazza IV Novembre 3,
20124 MILANO, Tel. +39 2 6752 2531, Fax. +39 2 6752 2557

Japan: Philips Bldg 13-37, Kohnan 2-chome, Minato-ku, TOKYO 108,
Tel. +81 3 3740 5130, Fax. +81 3 3740 5077

Korea: Philips House, 260-199 Itaewon-dong, Yongsan-ku, SEOUL,
Tel. +82 2 709 1412, Fax. +82 2 709 1415

Malaysia: No. 76 Jalan Universiti, 46200 PETALING JAYA, SELANGOR,
Tel. +60 3 750 5214, Fax. +60 3 757 4880

Mexico: 5900 Gateway East, Suite 200, EL PASO, TEXAS 79905,
Tel. +1 800 234 7381, Fax. +1 708 296 8556

Middle East: see Italy

Netherlands: Postbus 90050, 5600 PB EINDHOVEN, Bldg. VB,
Tel. +31 40 27 83749, Fax. +31 40 27 88399

New Zealand: 2 Wagener Place, C.P.O. Box 1041, AUCKLAND,
Tel. +64 9 849 4160, Fax. +64 9 849 7811

Norway: Box 1, Manglerud 0612, OSLO,
Tel. +47 22 74 8000, Fax. +47 22 74 8341

Philippines: Philips Semiconductors Philippines Inc.,
106 Valero St. Salcedo Village, P.O. Box 2108 MCC, MAKATI,
Metro MANILA, Tel. +63 2 816 6380, Fax. +63 2 817 3474

Poland: Ul. Lukiska 10, PL 04-123 WARSZAWA,
Tel. +48 22 612 2831, Fax. +48 22 612 2327

Portugal: see Spain

Romania: see Italy

Russia: Philips Russia, Ul. Usatcheva 35A, 119048 MOSCOW,
Tel. +7 095 926 5361, Fax. +7 095 564 8323

Singapore: Lorong 1, Toa Payoh, SINGAPORE 1231,
Tel. +65 350 2538, Fax. +65 251 6500

Slovakia: see Austria

Slovenia: see Italy

South Africa: S.A. PHILIPS Pty Ltd., 195-215 Main Road Martindale,
2092 JOHANNESBURG, P.O. Box 7430 Johannesburg 2000,
Tel. +27 11 470 5911, Fax. +27 11 470 5494

South America: Rua do Rocio 220, 5th floor, Suite 51,
04552-903 São Paulo, SÃO PAULO - SP, Brazil,
Tel. +55 11 821 2333, Fax. +55 11 829 1849

Spain: Balmes 22, 08007 BARCELONA,
Tel. +34 3 301 6312, Fax. +34 3 301 4107

Sweden: Kottbygatan 7, Akalla, S-16485 STOCKHOLM,
Tel. +46 8 632 2000, Fax. +46 8 632 2745

Switzerland: Allmendstrasse 140, CH-8027 ZÜRICH,
Tel. +41 1 488 2686, Fax. +41 1 481 7730

Taiwan: PHILIPS TAIWAN Ltd., 23-30F, 66,
Chung Hsiao West Road, Sec. 1, P.O. Box 22978,
TAIPEI 100, Tel. +886 2 382 4443, Fax. +886 2 382 4444

Thailand: PHILIPS ELECTRONICS (THAILAND) Ltd.,
209/2 Sanpavuth-Bangna Road Prakanong, BANGKOK 10260,
Tel. +66 2 745 4090, Fax. +66 2 398 0793

Turkey: Talatpasa Cad. No. 5, 80640 GÜLTEPE/ISTANBUL,
Tel. +90 212 279 2770, Fax. +90 212 282 6707

Ukraine: PHILIPS UKRAINE, 2A Akademika Koroleva str., Office 165,
252148 KIEV, Tel. +380 44 476 0297/1642, Fax. +380 44 476 6991

United Kingdom: Philips Semiconductors Ltd., 276 Bath Road, Hayes,
MIDDLESEX UB3 5BX, Tel. +44 181 730 5000, Fax. +44 181 754 8421

United States: 811 East Arques Avenue, SUNNYVALE, CA 94088-3409,
Tel. +1 800 234 7381, Fax. +1 708 296 8556

Uruguay: see South America

Vietnam: see Singapore

Yugoslavia: PHILIPS, Trg N. Pasica 5/v, 11000 BEOGRAD,
Tel. +381 11 825 344, Fax. +381 11 635 777

For all other countries apply to: Philips Semiconductors, Marketing & Sales Communications,
Building BE-p, P.O. Box 218, 5600 MD EINDHOVEN, The Netherlands, Fax. +31 40 27 24825

Internet: <http://www.semiconductors.philips.com/ps/>

© Philips Electronics N.V. 1996

SCA50

All rights are reserved. Reproduction in whole or in part is prohibited without the prior written consent of the copyright owner.

The information presented in this document does not form part of any quotation or contract, is believed to be accurate and reliable and may be changed without notice. No liability will be accepted by the publisher for any consequence of its use. Publication thereof does not convey nor imply any license under patent- or other industrial or intellectual property rights.

Printed in The Netherlands

517021/50/02/pp24

Date of release: 1996 Jul 17

Document order number: 9397 750 00965

Let's make things better.

**Philips
Semiconductors**



PHILIPS