

## Quadruple filter DAC

## TDA1314T

### FEATURES

- High dynamic range to enable digital DSP (Digital Signal Processor) volume control
- 18 bits data input format for each of the four channels
- Four times bit-serial oversampling filter
- 1st-order  $4f_{as}$  (audio sampling frequency) noise shaper
- Four very low noise DACs
- Only 1st-order analog post filtering required
- Smooth power-on of the DAC output currents
- Because of the automatic digital PLL divider range setting the master clock is selectable in a wide  $4f_{as}$  integer range
- Insensitive to jitter on the I<sup>2</sup>S-bus signals with respect to the DAC total harmonic distortion deterioration.

### APPLICATIONS

- Stand-alone quadruple low noise DAC
- Car radio DAC in conjunction with DSP.

### GENERAL DESCRIPTION

The TDA1314T is a quadruple very low noise high dynamic range DAC which is intended for use in motor cars and is controlled by the car radio DSP. Each channel incorporates an 8th-order IIR up-sampling filter from 1ASF to 4ASF followed by a 1st-order noise shaper and DAC. The DAC currents are converted to audio voltage signals using operational amplifiers (one per channel).

### QUICK REFERENCE DATA

$V_{ref} = 2.5$  and  $5$  V;  $T_{amb} = 25$  °C; all voltages referenced to ground; unless otherwise specified.

| SYMBOL       | PARAMETER  | CONDITIONS  | MIN.      | TYP.      | MAX.      | UNIT |
|--------------|--|---|-----------|-----------|-----------|------|
| $V_{DDA}$    | analog supply voltage  |   | 4.5       | 5.0       | 5.5       | V    |
| $V_{DDD}$    | digital supply voltage   |   | 4.5       | 5.0       | 5.5       | V    |
| $I_{O(DAC)}$ | DAC output current (FS)  | $R_{ref} = 20.5$ k $\Omega$                       | $\pm 0.4$ | $\pm 0.5$ | $\pm 0.6$ | mA   |
| $V_{O(DAC)}$ | DAC output voltage, nominal DAC operational amplifier output voltage | $R_L \geq 5$ k $\Omega$ ; $R_{fb} = 3$ k $\Omega$ | 1.0       | –         | 4.0       | V    |
| RES          | DAC resolution   | length of data input word                         | –         | –         | 18        | bits |
| (THD + N)/S  | total harmonic distortion plus noise-to-signal ratio                 | $f_i = 1$ kHz;<br>0 dB signal level               | –         | –66       | –56       | dB   |
| DR           | dynamic range of DAC   | $f_i = 1$ kHz;<br>–60 dB signal level             | 92        | 96        | –         | dB   |
| DS           | digital silence  | no signal; A-weighted                             | –         | –110      | –100      | dB   |
| $P_{tot}$    | total power dissipation  |   | –         | 85        | –         | mW   |
| $T_{amb}$    | operating ambient temperature  |   | –40       | +25       | +85       | °C   |

### ORDERING INFORMATION

| TYPE NUMBER | PACKAGE |  |          |
|-------------|---------|--|----------|
|             | NAME    | DESCRIPTION  | VERSION  |
| TDA1314T    | SO28    | plastic small outline package; 28 leads; body width 7.5 mm | SOT136-1 |

Quadruple filter DAC

TDA1314T

BLOCK DIAGRAM

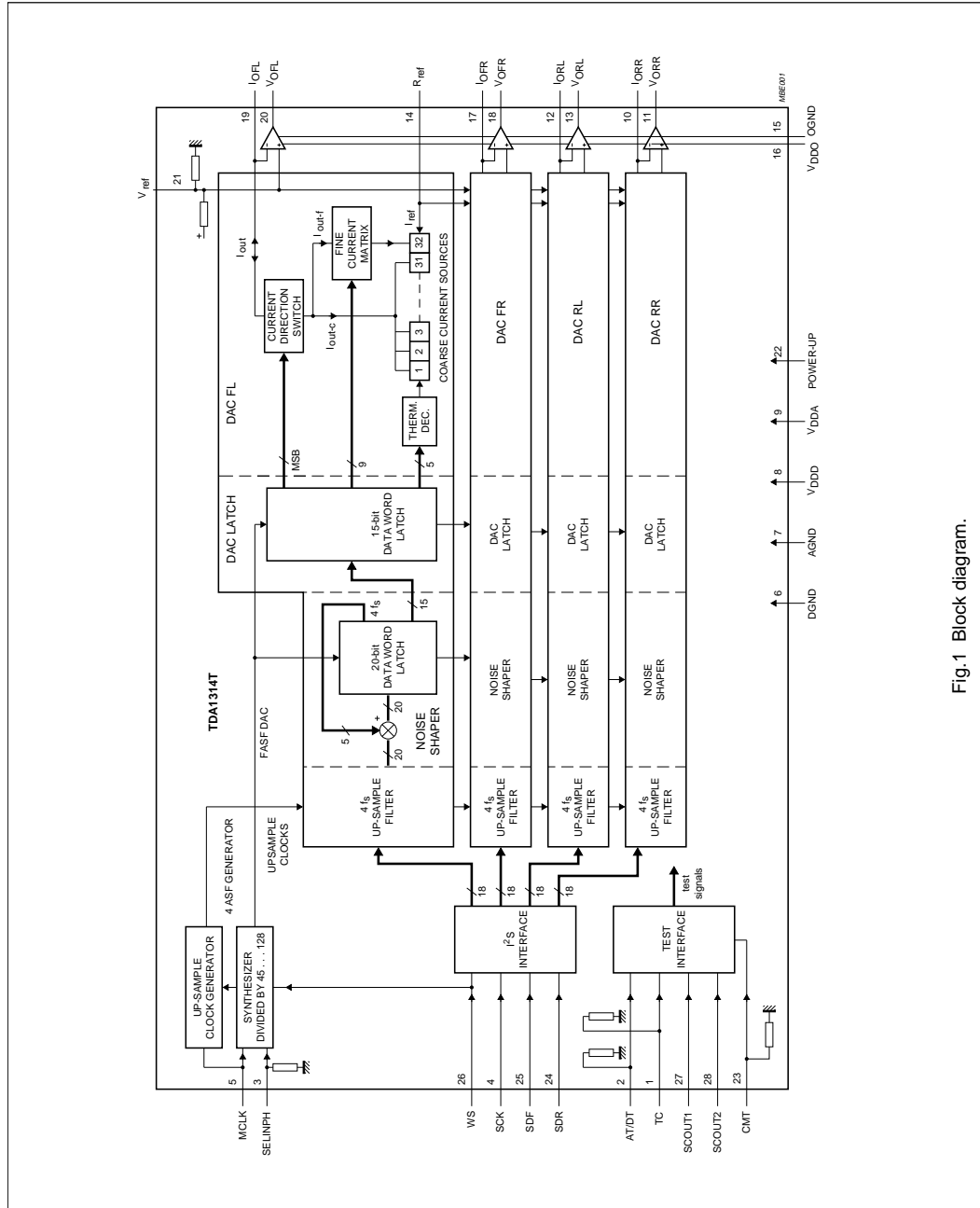

Fig. 1 Block diagram.

## Quadruple filter DAC

TDA1314T

## PINNING

| SYMBOL           | PIN | DESCRIPTION  |
|------------------|-----|--|
| TC               | 1   | test control signal input (test/operational)   |
| AT/DT            | 2   | analog test/digital test select input  |
| SELINPH          | 3   | select in-phase $4f_{as}$ mode/scan input signal 1 in test mode                          |
| SCK              | 4   | serial clock input; I <sup>2</sup> S-bus   |
| MCLK             | 5   | master clock input; $f_i = N \times 4f_{as}$ ( $45 \leq N \leq 128$ )                    |
| DGND             | 6   | digital ground   |
| AGND             | 7   | analog ground  |
| V <sub>DDD</sub> | 8   | digital supply voltage   |
| V <sub>DDA</sub> | 9   | analog supply voltage  |
| I <sub>ORR</sub> | 10  | DAC output current; rear right   |
| V <sub>ORR</sub> | 11  | DAC output voltage; rear right   |
| I <sub>ORL</sub> | 12  | DAC output current; rear left  |
| V <sub>ORL</sub> | 13  | DAC output voltage; rear left  |
| R <sub>ref</sub> | 14  | resistor reference input for DACs current  |
| OGND             | 15  | operational amplifier ground   |
| V <sub>DDO</sub> | 16  | operational amplifier supply   |
| I <sub>OFR</sub> | 17  | DAC output current; front right  |
| V <sub>OFR</sub> | 18  | DAC output voltage; front right  |
| I <sub>OFL</sub> | 19  | DAC output current; front left   |
| V <sub>OFL</sub> | 20  | DAC output voltage; front left   |
| V <sub>ref</sub> | 21  | reference voltage input ( $\frac{1}{2}$ operational amplifier supply voltage)            |
| POWER-UP         | 22  | analog mute input for all DACs   |
| CMT              | 23  | current mirror input test signal   |
| SDR              | 24  | serial data input for rear DACs (I <sup>2</sup> S-bus); scan input signal 2 in test mode |
| SDF              | 25  | serial data input for front DACs (I <sup>2</sup> S-bus)                                  |
| WS               | 26  | word select input (I <sup>2</sup> S-bus)   |
| SCOUT1           | 27  | scan output signal 1 in test mode; $4f_{as}$ signal                                      |
| SCOUT2           | 28  | scan output signal 2 in test mode; PLL lock indicator                                    |

## Quadruple filter DAC

## TDA1314T

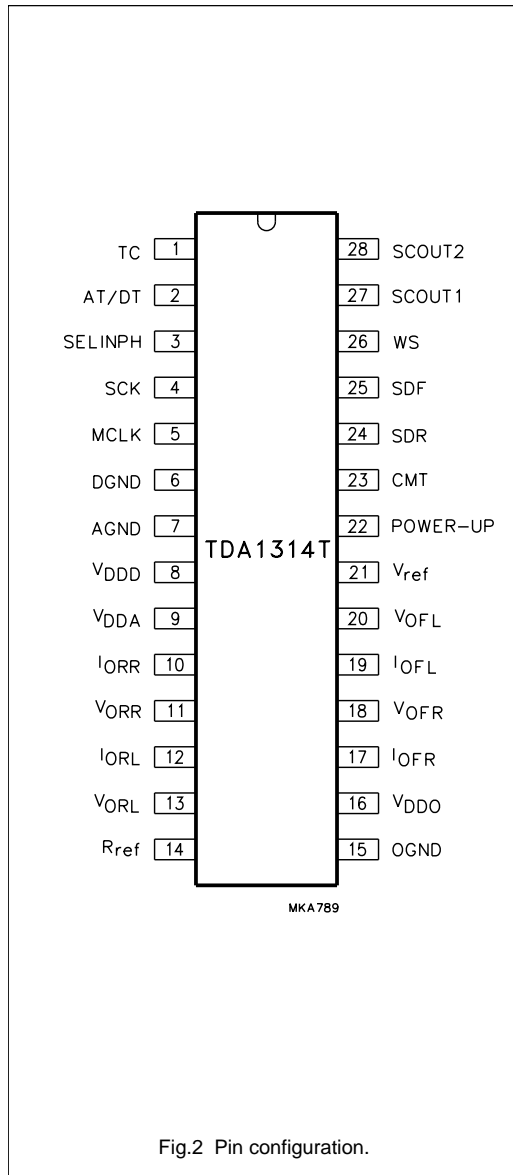
**FUNCTIONAL DESCRIPTION****I<sup>2</sup>S-bus interface**

The word select input (pin 26) is connected to the word select line of the I<sup>2</sup>S-bus interface. This interface has a standard I<sup>2</sup>S-bus specification as described in the Philips "I<sup>2</sup>S-bus specification" (ordering number 9398 332 10011). Figure 4 shows an excerpt of the Philips I<sup>2</sup>S-bus specification interface report with respect to the general timing and format of the I<sup>2</sup>S-bus. WS logic 0 means left channel word, logic 1 means right channel word.

The serial clock input (pin 4) must be in accordance with the I<sup>2</sup>S-bus specification, i.e. a continuous clock.

Serial data front (SDF, pin 25) and serial data rear (SDR, pin 24) are the I<sup>2</sup>S-bus serial data lines to be processed in the DACs for the loudspeakers of the car (see Fig.2, blocks DACFL and DACFR for the front loudspeakers and blocks DACRL and DACRR for the rear loudspeakers). FL stands for Front Left, FR for Front Right, RL for Rear Left and RR for Rear Right. In order to utilize the capabilities of this IC fully, the data word length should be 18 bits. Signals derived from this block are 4 × 18-bit parallel data words which are applied to the 4f<sub>s</sub> up-sample filters.

**4ASF generator****SYNTHESIZER**

SELINPH (pin 3) and WS (pin 26) are the data inputs for this block which generates the FASFDAC, this being the 4f<sub>as</sub> signal (at 4 times the audio sample frequency), which is used to latch the data words to the DACs and as a reference to the clock generator block for the up-sample filters. It consists of a digital PLL operating at the master clock signal MCLK (pin 5). In normal mode (i.e. in the event that the MCLK signal on pin 5 is a jitter free clock, with a frequency of integer multiples between 45 and 128, of 4 times the frequency of the WS signal) this block is able to generate a jitter free FASFDAC signal for optimum performance of the DAC. This mode is called the free running mode.

If, in some applications, there is considerable jitter on the MCLK while WS is more stable (less jitter), the phase-locked mode should be selected. This mode is normally not used and is not recommended.

## Quadruple filter DAC

TDA1314T

### UP-SAMPLE GENERATOR

This block generates the clocks for the up-sample filters. The external pinning of the  $4f_{as}$  generator block is:

- MCLK (see Fig.4), which is a jitter free (maximum 30 ns jitter) external clock at any multiple integer from 45 to 128 times  $4f_{as}$  (4 times the frequency of WS) of the I<sup>2</sup>S-bus input, thus for a sample frequency of 38 kHz this clock frequency will range from 6.840 MHz to 19.456 MHz in multiples of 152 kHz.
- The select in-phase (SELINPH) or free running mode of the synthesizer 45 to 128. In the normal application the free-running mode is used and this pin is not connected (this pin is pulled down by an internal resistor). The phase-locked mode can be selected by hard-wiring this pin to V<sub>DD</sub> (pin 8). However, this mode is not recommended.

### Test interface

This block controls the circuit in the test mode, which can be either an analog or digital test mode. Test pins TC (pin 1), AT/DT (pin 2), CMT (pin 23), SCOUT1 (pin 27) and SCOUT2 (pin 28) are not connected in Fig.6.

### Up-sample filter and noise shaper

The signal flow applied to the up-sample filter and noise shaper blocks is the  $4 \times 18$ -bit parallel data words in two's complement format from the I<sup>2</sup>S-bus interface at the audio sampling frequency. The signal flow from these blocks is the  $4 \times 15$ -bit parallel data words in two's complement format at a frequency of  $4f_{as}$ . Each of the four digital filters is a four times up-sampling filter. This up-sampling filter is an elliptic filter of 8th order.

The filters produce an attenuation of 29 dB (min) for signals outside the audio band. The noise shaper operates at  $4f_{as}$  and reduces the word length from 22 bits to 15 bits which is the word length of the DAC.

### DAC input signals

The following signals are input to the DAC blocks FL, FR, RL and RR:

- DATA WORD (bits 10 to 14). These 5 bits are used to control, via a thermometer decoder, the current of the 32 coarse current sources of the analog DAC part. The value of this data word determines the total coarse current flowing to the DAC current output. The value of the current of each coarse current source is determined by the following:
  - $R_{ref}$ , this is the current reference input at pin 14 and is at the same voltage level as  $V_{ref}$ . A resistor connected to OGND results in a current. This being the reference current of the coarse current sources and subsequently of the DAC in total.
- DATA WORD (bits 1 to 9). A current from one of the coarse current sources is fed into a 512 transistor matrix. The value of the DATA WORD (bits 1 to 9) determines which part of one coarse current flows to the DAC current output.
- DATA WORD (bit 15). This data word MSB controls the direction of the flow of the DAC output current by switching the current direction switch.
- $V_{ref}$ . Voltage reference pin internally connected to a resistor divider to obtain half of the power supply voltage. This voltage is buffered and used as reference voltage input for the operational amplifiers and as a reference voltage in the DAC.
- POWER-UP. The analog signal on this pin controls the current biasing circuit of the DACs. This pin is connected internally via a high value resistor to V<sub>DDA</sub>. Together with an external capacitor a soft switch-on of the DAC output currents is obtained. This pin can also be used as the analog mute input for all DAC output currents by pulling it to ground.

Quadruple filter DAC

TDA1314T

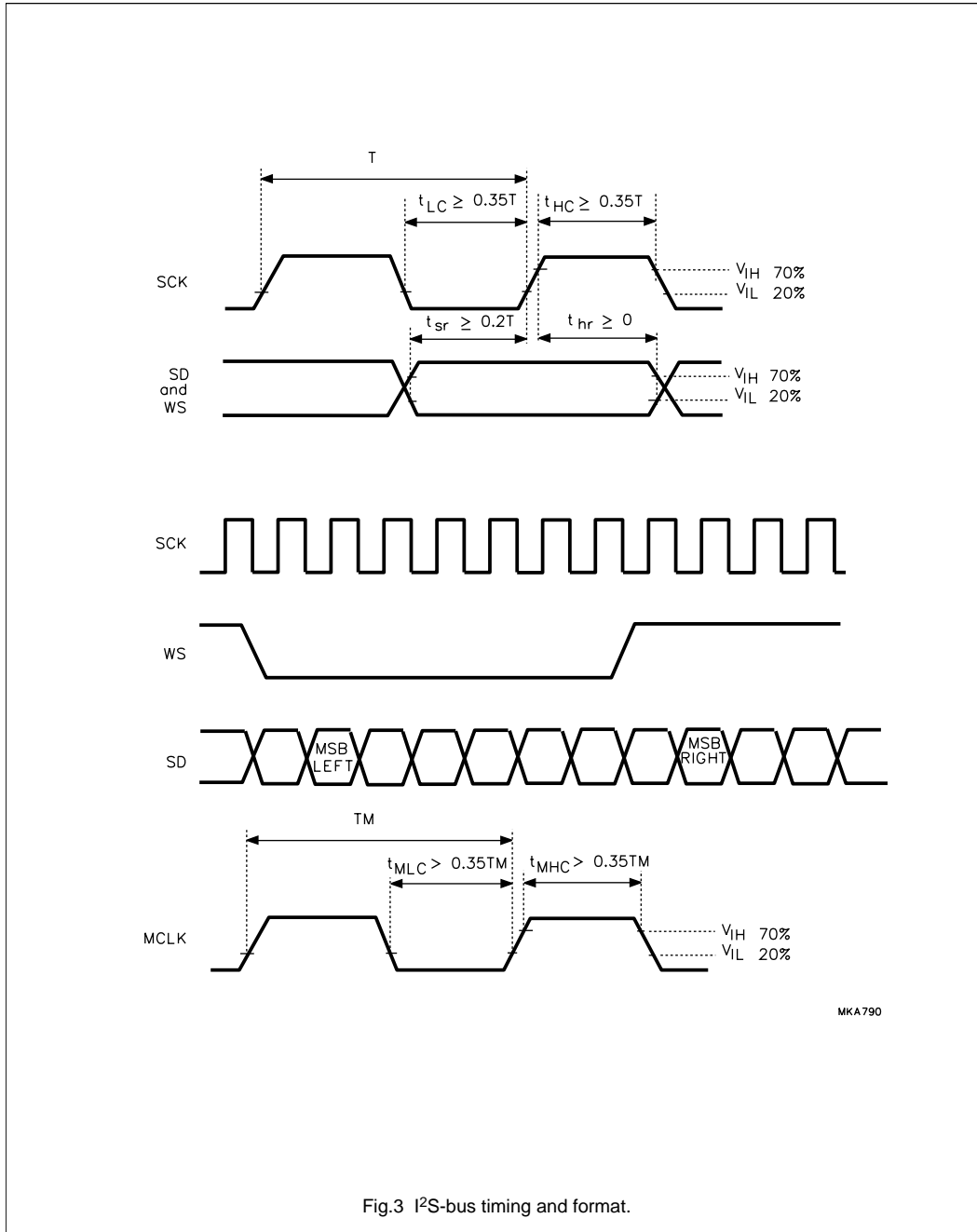

Fig.3 I<sup>2</sup>S-bus timing and format.

## Quadruple filter DAC

TDA1314T

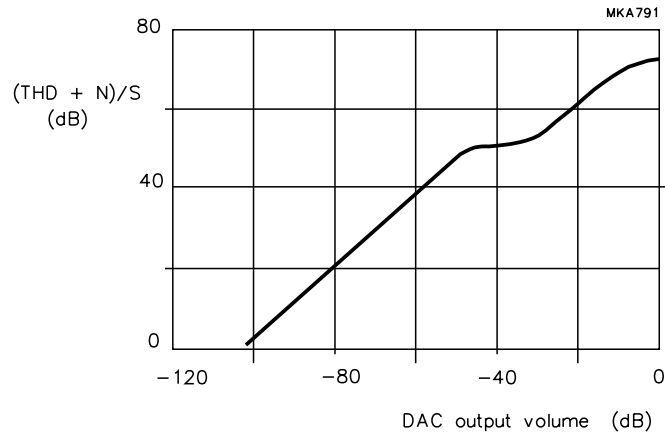

Fig.4 Total harmonic distortion plus noise-to-signal ratio as a function of output volume.

**LIMITING VALUES**

In accordance with the Absolute Maximum Rating System (IEC 134).

| SYMBOL            | PARAMETER                            | CONDITIONS | MIN.  | MAX.            | UNIT |
|-------------------|--------------------------------------|------------|-------|-----------------|------|
| V <sub>DDD</sub>  | digital supply voltage               | note 1     | 0     | 6.0             | V    |
| V <sub>DDA</sub>  | analog supply voltage                | note 1     | 0     | 6.0             | V    |
| V <sub>DDO</sub>  | operational amplifier supply voltage | note 1     | 0     | 6.0             | V    |
| V <sub>n</sub>    | voltage on any other pin             |            | 0     | V <sub>DD</sub> | V    |
| T <sub>xtal</sub> | crystal temperature                  |            | -     | +150            | °C   |
| T <sub>stg</sub>  | storage temperature                  |            | -55   | +150            | °C   |
| T <sub>amb</sub>  | operating ambient temperature        |            | -40   | +85             | °C   |
| V <sub>es</sub>   | electrostatic handling               | note 2     | -2000 | +2000           | V    |

**Notes**

- All voltages (pins 6, 7 and 15) referenced to ground.
- Equivalent to discharging a 100 pF capacitor through a 1.5 kΩ series resistor.

**THERMAL CHARACTERISTICS**

| SYMBOL              | PARAMETER   | VALUE | UNIT |
|---------------------|---|-------|------|
| R <sub>th j-a</sub> | thermal resistance from junction to ambient in free air | 76    | K/W  |

## Quadruple filter DAC

## TDA1314T

**DC CHARACTERISTICS**

$V_{DD} = 4.5$  to  $5.5$  V;  $V_{DDA} = V_{DDO} = 4.75$  to  $5.25$  V; all voltage referenced to ground (pins 6, 7 and 15); measured in test circuit of Fig.6;  $T_{amb} = 25$  °C; unless otherwise specified.

| SYMBOL          | PARAMETER   | CONDITIONS  | MIN.            | TYP.          | MAX.             | UNIT       |
|-----------------|---|---|-----------------|---------------|------------------|------------|
| $V_{DDD}$       | digital supply voltage  |   | 4.5             | 5.0           | 5.5              | V          |
| $V_{DDA}$       | analog supply voltage   |   | 4.75            | 5.0           | 5.25             | V          |
| $V_{DDO}$       | operational amplifier supply voltage  |   | 4.75            | 5.0           | 5.25             | V          |
| $I_{DDD}$       | digital supply current  | MCLK = 6.84 MHz   | –               | 10            | 17               | mA         |
| $I_{DDA}$       | analog supply current   | at digital silence  | –               | 5             | 8                | mA         |
| $I_{DDO}$       | operational amplifiers supply current   | no operational amplifier load resistor  | –               | 2             | 4                | mA         |
| $P_{tot}$       | total power dissipation   | MCLK = 6.84 MHz;<br>at digital silence;<br>no operational amplifier load resistor | –               | 85            | 145              | mW         |
| $V_{IH}$        | HIGH level input voltage<br>pins 1 to 5 and 23 to 26                                |   | $0.7V_{DDD}$    | –             | –                | V          |
| $V_{IL}$        | LOW level input voltage<br>pins 1 to 5 and 23 to 26                                 |   | –               | –             | $0.2V_{DDD}$     | V          |
| $V_{OH}$        | HIGH level output voltage<br>pins 27 and 28   | $V_{DDD} = 4.5$ V; $I_O = -4$ mA  | 4.1             | –             | –                | V          |
|                 |   | $V_{DDD} = 5.5$ V; $I_O = -4.5$ mA  | 5.1             | –             | –                | V          |
| $V_{OL}$        | LOW level output voltage<br>pins 27 and 28  | $V_{DDD} = 4.5$ V; $I_O = 4$ mA   | –               | –             | 0.4              | V          |
|                 |   | $V_{DDD} = 5.5$ V; $I_O = 4.5$ mA   | –               | –             | 0.4              | V          |
| $V_{ref}$       | reference input voltage   | with respect to OGND  | $0.45V_{DDO}$   | $0.5V_{DDO}$  | $0.55V_{DDO}$    | V          |
| $Z_I$           | input impedance at pin 21   | with respect to $V_{DDO}$   | 15              | 20            | 30               | k $\Omega$ |
|                 |   | with respect to OGND  | 15              | 20            | 30               | k $\Omega$ |
| $V_I$           | input voltage pin 14  | with respect to OGND  | $0.43V_{DDO}$   | $0.5V_{DDO}$  | $0.57V_{DDO}$    | V          |
| $I_{ODAC(max)}$ | maximum output current<br>from DACs pins 10, 12, 17<br>and 19                       | $R_{ref} = 20.5$ k $\Omega$ ; $V_{DDO} = 5$ V                                     | 400             | 500           | 600              | $\mu$ A    |
| $V_{O(os)}$     | DC offset voltage at pins 10,<br>12, 17 and 19                                      | with respect to $V_{ref}$   | –               | 5             | –                | mV         |
| $V_{OH(O)}$     | HIGH level output voltage of<br>operational amplifiers at<br>pins 11, 13, 18 and 20 | note 1; $R_L > 5$ k $\Omega$ ;<br>$R_{fb} = 3$ k $\Omega$ ;<br>maximum signal     | $V_{DDO} - 1.3$ | $V_{DDO} - 1$ | $V_{DDO} - 0.45$ | V          |
| $V_{OL(O)}$     | LOW level output voltage of<br>operational amplifiers at<br>pins 11, 13, 18 and 20  | note 1; $R_L > 5$ k $\Omega$ ;<br>$R_{fb} = 3$ k $\Omega$ ;<br>maximum signal     | 0.45            | 1.0           | 1.3              | V          |
| $R_{pu}$        | internal resistance at pin 22   | with respect to $V_{DDO}$   | 110             | 160           | 240              | k $\Omega$ |
| $R_{pd}$        | internal resistance at<br>pins 1 to 3 and 23  | $V_i = V_{DDD}$ ; with respect to<br>DGND   | 27              | –             | 80               | k $\Omega$ |

**Note**

- $R_L$  is the AC impedance of the external circuitry connected to the audio outputs in the application diagram of Fig.6.



## Quadruple filter DAC

TDA1314T

**AC CHARACTERISTICS**

$V_{DDD} = V_{DDA} = V_{DDO} = 5\text{ V}$ ;  $T_{\text{amb}} = 25\text{ }^{\circ}\text{C}$ ; all voltages referenced to ground (pins 6, 7 and 15) measured in test circuit of Fig.5; unless otherwise specified.

| SYMBOL                        | PARAMETER   | CONDITIONS   | MIN. | TYP. | MAX. | UNIT     |
|-------------------------------|---|--|------|------|------|----------|
| <b>ANALOG</b>                 |   |  |      |      |      |          |
| DACs                          |   |  |      |      |      |          |
| SVRR                          | supply voltage ripple rejection pins 9 and 16   | $f_{\text{ripple}} = 1\text{ kHz}$ ;<br>$V_{\text{ripple}} = 100\text{ mV (peak)}$ ;<br>$C_{V_{\text{ref}}} = 22\text{ }\mu\text{F}$         | 30   | 46   | –    | dB       |
| $\Delta I_{O(\text{DAC})}$    | maximum deviation of output level of the 4 DAC output currents with respect to the average of the 4 outputs | maximum volume   | –    | –    | 0.38 | dB       |
| $\alpha_{\text{DAC}}$         | crosstalk between the 4 DAC current outputs   | 2 outputs at digital silence; 2 outputs at maximum volume  | –    | –90  | –60  | dB       |
| RES                           | DAC resolution  |  | –    | –    | 18   | bits     |
| (THD + N)/S                   | total harmonic distortion plus noise-to-signal ratio  | $f_i = 1\text{ kHz}$ ; 0 dB signal   | –    | –66  | –56  | dB       |
|                               |   | $f_i = 1\text{ kHz}$ ; –60 dB signal; A-weighted   | –    | –36  | –32  | dB       |
| DR                            | dynamic range   | $f_i = 1\text{ kHz}$ ; –60 dB signal; A-weighted   | 92   | 96   | –    | dB       |
| DS                            | digital silence   | $f_i = 20\text{ Hz}$ to 17 kHz; A-weighted   | –    | –110 | –100 | dB       |
| <b>Operational amplifiers</b> |   |  |      |      |      |          |
| $G_v$                         | open loop voltage gain  |  | –    | 85   | –    | dB       |
| PSRR                          | power supply ripple rejection   | $f_{\text{ripple}} = 3\text{ kHz}$ ;<br>$V_{\text{ripple}} = 100\text{ mV (peak)}$   | –    | 90   | –    | dB       |
| (THD + N)/S                   | total harmonic distortion plus noise as a function of the operational amplifiers signal                     | $R_L > 5\text{ k}\Omega$ (AC);<br>$R_{\text{fb}} = 3\text{ k}\Omega$ ;<br>$V_O = 0.28\text{ V (p-p)}$ ;<br>$f_i = 1\text{ kHz}$ ; A-weighted | –    | –82  | –    | dB       |
| $f_{\text{ug}}$               | unity gain frequency  | open loop  | –    | 4.5  | –    | MHz      |
| $Z_o$                         | output impedance  | $R_L > 5\text{ k}\Omega$   | –    | 1.5  | 150  | $\Omega$ |

## Quadruple filter DAC

TDA1314T

| SYMBOL  | PARAMETER  | CONDITIONS                                       | MIN.                  | TYP.                  | MAX.                   | UNIT |
|---|--|--|-----------------------|-----------------------|------------------------|------|
| <b>DIGITAL</b>  |  |  |                       |                       |                        |      |
| I <sup>2</sup> S-BUS, UP-SAMPLING FILTER AND NOISE SHAPER |  |  |                       |                       |                        |      |
| f <sub>SCK</sub>  | serial clock input frequency                               | ASF = 38 kHz                                     | 1.368                 | –                     | 19.456                 | MHz  |
| t <sub>LC</sub>   | serial clock LOW time                                      | at 20% V <sub>DD</sub> ; $T = \frac{1}{f_{SCK}}$ | 0.35T                 | –                     | –                      | μs   |
| t <sub>HC</sub>   | serial clock HIGH time                                     | at 70% V <sub>DD</sub> ; $T = \frac{1}{f_{SCK}}$ | 0.35T                 | –                     | –                      | μs   |
| f <sub>WS</sub>   | word select input frequency                                |  | 38                    | 44.1                  | 48                     | kHz  |
| t <sub>sr</sub>   | set-up time from SDF, SDR and WS to HIGH going edge of SCK | $T = \frac{1}{f_{SCK}}$                          | 0.2T                  | –                     | –                      | μs   |
| t <sub>hr</sub>   | hold time from SDF, SDR and WS to HIGH going edge of SCK   | $T = \frac{1}{f_{SCK}}$                          | 0                     | –                     | –                      | μs   |
| f <sub>MCLK</sub>   | master clock input frequency                               | N × 4 × f <sub>WS</sub> ; where N = integer      | 45 × 4f <sub>WS</sub> | 64 × 4f <sub>WS</sub> | 128 × 4f <sub>WS</sub> | kHz  |
| t <sub>MLC</sub>  | master clock LOW time                                      | $TM = \frac{1}{f_{SCK}}$                         | 0.35TM                | –                     | –                      | μs   |
| t <sub>MHC</sub>  | master clock HIGH time                                     | $TM = \frac{1}{f_{SCK}}$                         | 0.35TM                | –                     | –                      | μs   |
| PR  | pass band ripple of digital filter                         | with sample-and-hold from DAC                    | –                     | 0.46                  | –                      | dB   |
| α <sub>SB</sub>   | stop band attenuation                                      | f <sub>i</sub> > 22 kHz; no post filter          | 29                    | –                     | –                      | dB   |

Quadruple filter DAC

TDA1314T

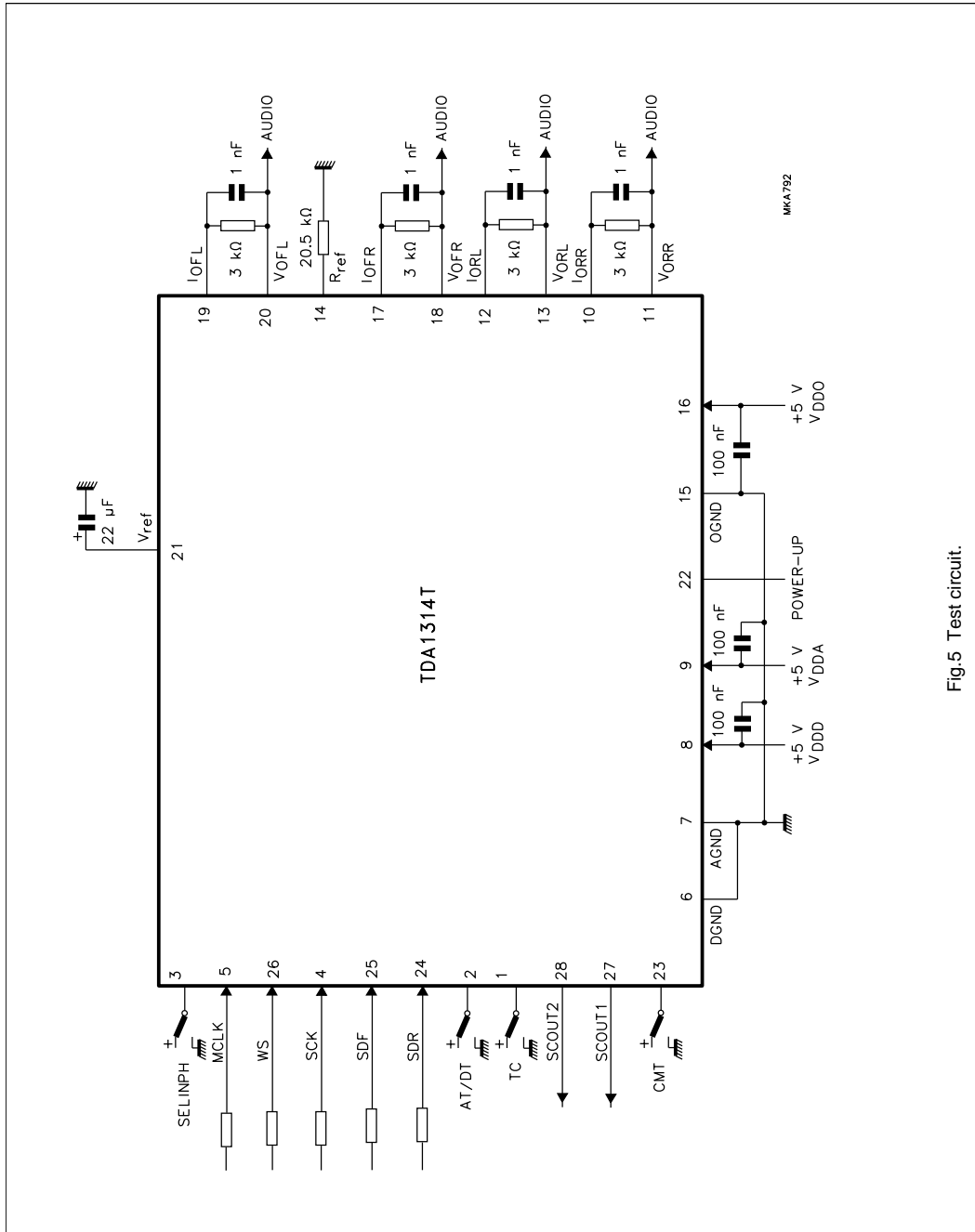

Fig.5 Test circuit.

---

## Quadruple filter DAC

## TDA1314T

---

### APPLICATION INFORMATION

The application diagram is illustrated in Fig.6.

All pins used for testing (pins 1, 2, 23, 27 and 28 need not to be connected due to internal resistors being connected to ground or being used as test outputs. In the normal free-running mode it is also not required to connect pin 3.

Jitter on the clock edges of MCLK must be as low as possible so as not to deteriorate the DAC THD performance. The jitter time must not be greater than 30 ns.

$V_{ref}$  is the voltage reference pin with an internal resistor divider. A capacitor of 22  $\mu$ F is used to get the specified power ripple rejection ratio.

The output operational amplifiers are current-to-voltage converters by means of the 3 kW resistors connected between the DAC current outputs (pins 10, 12, 17 and 19) and the voltage outputs (pins 11, 13, 18 and 20) respectively. The voltage on the DAC current outputs is equal to the operational amplifiers virtual ground at  $V_{ref}$  in the event that the operational amplifier is used according to the application diagram of Fig.6.

Care should be taken, in order to reduce the electromagnetic compatibility (EMC) that the bandwidth of the digital signals being applied to pins MCLK, WS, SCK, SDF and SDR is not larger than necessary. This can be achieved by controlling the slew rate of the digital source outputs or connecting a series resistor close to the digital source output of the driving circuits.

The resistor connected between  $R_{ref}$  (pin 14) and ground is the current reference of the DACs. The voltage on  $R_{ref}$  is equal to  $V_{ref}$ .

On the printed-circuit board  $V_{SSA}$  (pin 7) is also the substrate and has the most negative voltage of the IC, a large as possible ground plane is therefore recommended. The connection between  $V_{SSA}$ ,  $V_{SSD}$  and  $V_{SSO}$  must be as short as possible. Pins  $V_{DDO}$  and  $V_{DDA}$  (pins 9 and 16) must have capacitors connected to the  $V_{SSA}$  ground plane closest to the chip. Pin  $V_{DDD}$  (pin 8) is fed via a small series resistor (25  $\Omega$ ). This resistor must be connected as close as possible to pin 8.

The POWER-UP (pin 22) is connected via an electrolytic capacitor to ground. This results in a smooth rising of the DAC output currents at power-on. If this is not required then this capacitor can be omitted.

Suppression of the higher harmonics by the up-sample filter should be sufficient to protect the amplifiers and the tweeter loudspeakers from excessive HF noise. The band around  $4f_s$  cannot be attenuated by the 4ASF filter and is only attenuated by the sample-and-hold effect of the DAC. At frequencies above 100 kHz, additional attenuation achieved by the 1st order post filter, which is built around the buffer operational amplifiers. In total a 2nd order level of filtering can be found above 100 kHz. In terms of power the audio out-of-band power is approximately  $15 \times 10^{-4}$  of the audio in-band power.

Quadruple filter DAC

TDA1314T

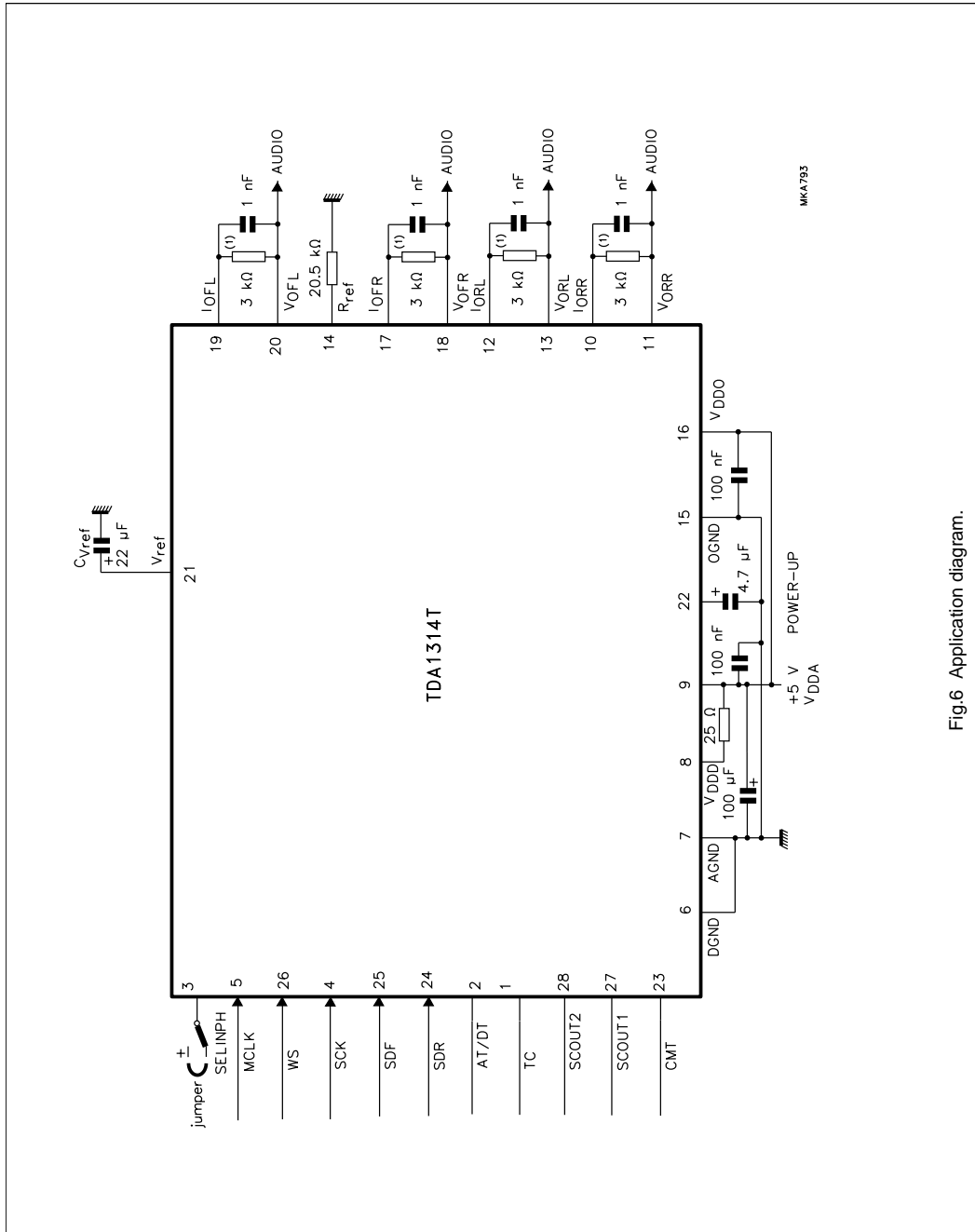
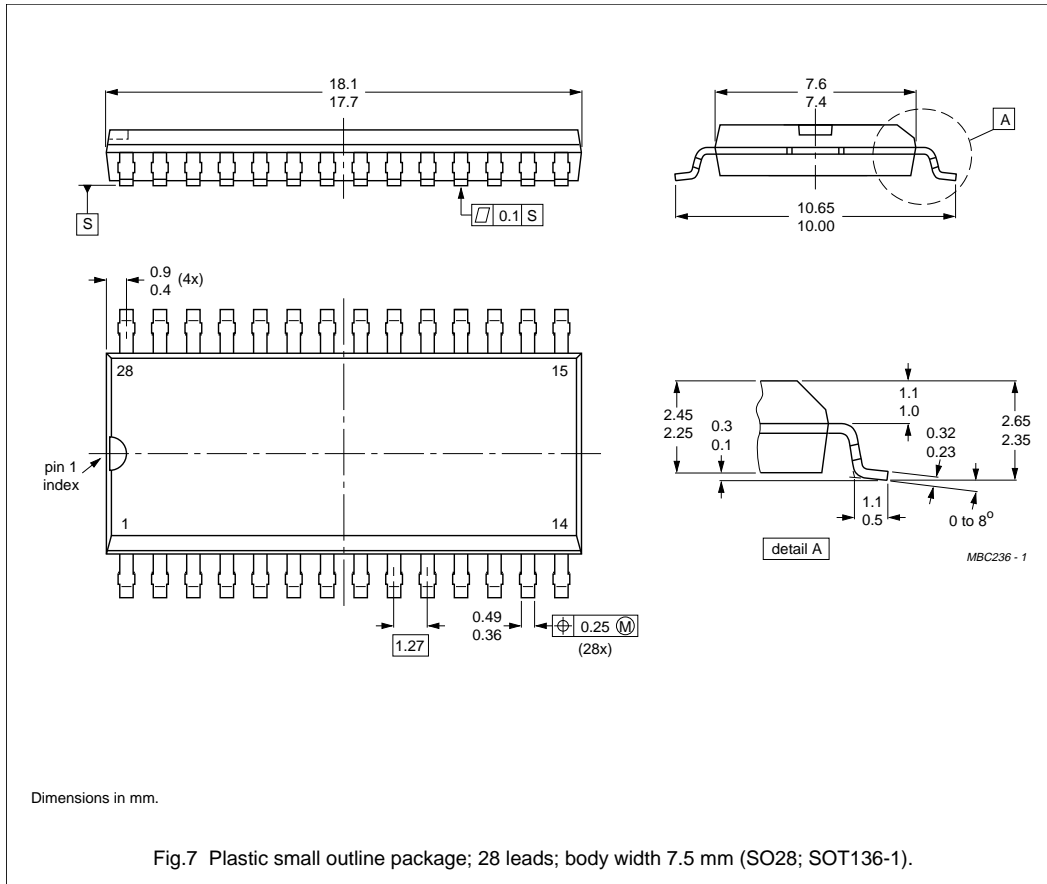

Fig.6 Application diagram.

Quadruple filter DAC

TDA1314T

PACKAGE OUTLINE



## Quadruple filter DAC

TDA1314T

### SOLDERING INFORMATION

#### Plastic small-outline packages

##### BY WAVE

During placement and before soldering, the component must be fixed with a droplet of adhesive. After curing the adhesive, the component can be soldered. The adhesive can be applied by screen printing, pin transfer or syringe dispensing.

Maximum permissible solder temperature is 260 °C, and maximum duration of package immersion in solder bath is 10 s, if allowed to cool to less than 150 °C within 6 s. Typical dwell time is 4 s at 250 °C.

A modified wave soldering technique is recommended using two solder waves (dual-wave), in which a turbulent wave with high upward pressure is followed by a smooth laminar wave. Using a mildly-activated flux eliminates the need for removal of corrosive residues in most applications.

##### BY SOLDER PASTE REFLOW

Reflow soldering requires the solder paste (a suspension of fine solder particles, flux and binding agent) to be applied to the substrate by screen printing, stencilling or pressure-syringe dispensing before device placement.

Several techniques exist for reflowing; for example, thermal conduction by heated belt, infrared, and vapour-phase reflow. Dwell times vary between 50 and 300 s according to method. Typical reflow temperatures range from 215 to 250 °C.

Preheating is necessary to dry the paste and evaporate the binding agent. Preheating duration: 45 min at 45 °C.

##### REPAIRING SOLDERED JOINTS (BY HAND-HELD SOLDERING IRON OR PULSE-HEATED SOLDER TOOL)

Fix the component by first soldering two, diagonally opposite, end pins. Apply the heating tool to the flat part of the pin only. Contact time must be limited to 10 s at up to 300 °C. When using proper tools, all other pins can be soldered in one operation within 2 to 5 s at between 270 and 320 °C. (Pulse-heated soldering is not recommended for SO packages.)

For pulse-heated solder tool (resistance) soldering of VSO packages, solder is applied to the substrate by dipping or by an extra thick tin/lead plating before package placement.

### DEFINITIONS

| Data sheet status   |   |
|---|---|
| Objective specification   | This data sheet contains target or goal specifications for product development.       |
| Preliminary specification   | This data sheet contains preliminary data; supplementary data may be published later. |
| Product specification   | This data sheet contains final product specifications.                                |
| Limiting values   |   |
| Limiting values given are in accordance with the Absolute Maximum Rating System (IEC 134). Stress above one or more of the limiting values may cause permanent damage to the device. These are stress ratings only and operation of the device at these or at any other conditions above those given in the Characteristics sections of the specification is not implied. Exposure to limiting values for extended periods may affect device reliability. |   |
| Application information   |   |
| Where application information is given, it is advisory and does not form part of the specification.   |   |

### LIFE SUPPORT APPLICATIONS

These products are not designed for use in life support appliances, devices, or systems where malfunction of these products can reasonably be expected to result in personal injury. Philips customers using or selling these products for use in such applications do so at their own risk and agree to fully indemnify Philips for any damages resulting from such improper use or sale.