

5.1ch Surround Processor

■ GENERAL DESCRIPTION

The **NJW1186** is an Surround Processor for 5.1ch speaker system regenerating Center, Surround and Subwoofer channel signal from normal stereo signal input. The **NJW1186** contains Passive Matrix circuit, BPF for center channel, LPF for subwoofer, simulated stereo function for surround channel and trimmers for each channel.

All of internal status and variables are controlled by I²C BUS.
It is suitable for TV set, Home Theater and the others.

■ PACKAGE OUTLINE

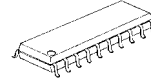

NJW1186M

■ FEATURES

- Operating Voltage 7.5 to 13V
- I²C BUS Interface
- Passive Matrix Surround Circuit
- Trimmer & BPF for Center Channel
- Trimmer & LPF for Subwoofer Channel
- Trimmer & Simulated Stereo Function for Surround Channel
- Bi-CMOS Technology
- Package Outline DMP20

■ BLOCK DIAGRAM

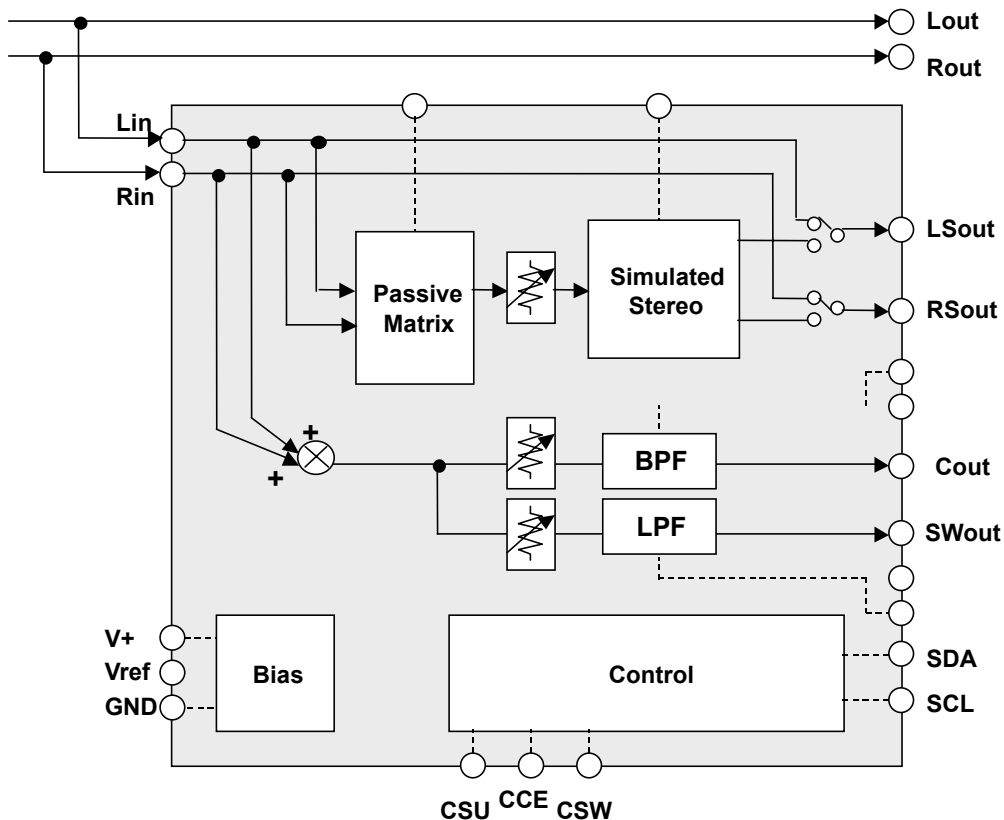

■ PIN CONFIGURATION



No.	SYMBOL	FUNCTION
1	SWout	Subwoofer Channel Output
2	SWFilin	LPF for Subwoofer Channel
3	SW'out	Subwoofer Channel Trimmer Output
4	RSout	Right Surround Channel Output
5	Rin	Right Channel Input
6	Lin	Left Channel Input
7	LSout	Left Surround Channel Output
8	C'out	Center Channel Trimmer Output
9	CFilin	BPF for Center Channel
10	Cout	Center Channel Output
11	PS	Filter for Simulated Stereo
12	CSU	Pop Noise Reduction for Left Surround & Right Surround Channel Trimmer
13	SDA	I ² C Bus Data Input
14	SCL	I ² C Bus Clock Input
15	GND	Ground
16	V+	Power Supply
17	Vrefin	Reference Voltage Stabilizing Capacitor
18	CCE	Pop Noise Reduction for Center Channel Trimmer
19	CSW	Pop Noise Reduction for Subwoofer Channel Trimmer
20	Filter	Filter for Surround Channel

■ ABSOLUTE MAXIMUM RATING (Ta=25°C)

PARAMETER	SYMBOL	RATING	UNIT
Supply Voltage	V ⁺	15	V
Power Dissipation	P _D	350	mW
Maximum Input Voltage	V _{IM}	0 to V ⁺	V
Operating Temperature Range	Topr	-40 to +85	°C
Storage Temperature Range	Tstg	-40 to +125	°C

■ RECOMMENDED OPERATING CONDITION

PARAMETER	SYMBOL	TEST CONDITION	MIN.	TYP.	MAX.	UNIT
Operating Voltage	V ⁺	-	7.5	9.0	13.0	V

■ ELECTRICAL CHARACTERISTICS

(Ta=25°C, V⁺=9V, R_g=600Ω, R_L=47kΩ, SIM="0", SRSEL="1" unless otherwise specified)

◆ Power Supply

PARAMETER	SYMBOL	TEST CONDITION	MIN.	TYP.	MAX.	UNIT
Supply Current	I _{CC}	No Signal	-	6	10	mA
Reference Voltage	V _{REF}	No Signal	4.0	4.5	5.0	V

◆ AC CHARACTERISTICS

PARAMETER	SYMBOL	TEST CONDITION	MIN.	TYP.	MAX.	UNIT
Input Impedance	R _i		-	24	-	kΩ

◆ Center Channel Output (Lin=Rin=100mVrms, f=1kHz unless otherwise specified)

PARAMETER	SYMBOL	TEST CONDITION	MIN.	TYP.	MAX.	UNIT
Maximum Input Voltage	V _{IMC}	THD=7%	2.8	3.0	-	Vrms
Voltage Gain	G _{VC}	BCC="0", C-TRIM="0000", C-MUTE="1"	-2.0	0	2.0	dB
Maximum Gain	G _{VMAXC}	BCC="1", C-TRIM="1111", C-MUTE="1"	12.5	15.0	17.5	
Minimum Gain	G _{VMINC}	BCC="0", C-TRIM="1111", C-MUTE="1"	-	-15.0	-	
Mute Level	G _{VMUTE}	C-MUTE="0", Lin= 1Vrms, Rin=0	-	-80	-70	
Total Harmonic Distortion	THD _C	BCC="0", C-TRIM="0000", C-MUTE="1", BW=400Hz to 30kHz, Lin=Rin=500mVrms	-	0.1	0.5	%
Output Noise 1	V _{NO1C}	BCC="0", C-TRIM="0000", C-MUTE="1", No Signal, A-Weighted, Rg=0Ω	-	-94 (19.6)	-85 (56.2)	dBV (μVrms)
Output Noise 2	V _{NO2C}	C-MUTE="0", No Signal, A-Weighted, Rg=0Ω	-	-106 (5.0)	-96 (15.8)	

◆Subwoofer Channel Output (Lin=Rin=100mVrms, f=1kHz unless otherwise specified)

PARAMETER	SYMBOL	TEST CONDITION	MIN.	TYP.	MAX.	UNIT
Maximum Input Voltage	V_{IMW}	THD=7%	2.8	3.0	-	Vrms
Voltage Gain	G_{VW}	BCW="0", W-TRIM="0000", W-MUTE="1"	-2.0	0	2.0	dB
Maximum Gain	G_{VMAXW}	BCW="1", W-TRIM="1111", C-MUTE="1"	12.5	15.0	17.5	
Minimum Gain	G_{VMINW}	BCW="0", W-TRIM="1111", W-MUTE="1"	-	-15.0	-	
Mute Level	G_{VMUTEW}	W-MUTE="0", Lin= 1Vrms, Rin=0	-	-80	-70	
Total Harmonic Distortion	THD_W	BCW="0", W-TRIM="0000", W-MUTE="1", BW=400Hz to 30kHz, Lin=Rin=500mVrms	-	0.1	0.5	%
Output Noise 1	V_{NO1W}	BCW="0", W-TRIM="0000", W-MUTE="1", No Signal, A-Weighted, Rg=0Ω	-	-94 (19.6)	-85 (56.2)	dBV (μVrms)
Output Noise 2	V_{NO2W}	W-MUTE="0", No Signal, A-Weighted, Rg=0Ω	-	-106 (5.0)	-96 (15.8)	

◆Left Surround Channel Output (Lin= 100mVrms, Rin=0, f=1kHz unless otherwise specified)

PARAMETER	SYMBOL	TEST CONDITION	MIN.	TYP.	MAX.	UNIT
Maximum Input Voltage	V_{IMLS}	THD=5%	2.8	3.0	-	Vrms
Bypass Gain	G_{VPASSL}	SRSEL=Bypass, Lin=Rin=100mVrms	-2.0	0	2.0	dB
Voltage Gain	G_{VLS}	BCS="0", S-TRIM="0000", S-MUTE="1", f=100Hz	-2.0	0	2.0	
Maximum Gain	G_{VMAXLS}	BCS="1", S-TRIM="1111", S-MUTE="1", f=100Hz	12.5	15.0	17.5	
Minimum Gain	G_{VMINLS}	BCS="0", S-TRIM="1111", S-MUTE="1", f=100Hz	-	-15.0	-	
Mute Level	$G_{VMUTELS}$	S-MUTE="0", Lin=1Vrms, Rin=0	-	-80	-70	
Total Harmonic Distortion	THD_{LS}	BCS="0", S-TRIM="0000", S-MUTE="1", BW=400Hz to 30kHz, Lin=500mVrms, Rin=0	-	0.1	0.5	%
Output Noise 1	V_{NO1LS}	BCS="0", S-TRIM="0000", S-MUTE="1", No Signal, A-Weighted, Rg=0Ω	-	-94 (19.6)	-85 (56.2)	dBV (μVrms)
Output Noise 2	V_{NO2LS}	S-MUTE="0", No Signal, A-Weighted, Rg=0Ω	-	-106 (5.0)	-96 (15.8)	

◆Right Surround Channel Output (Lin=0, Rin=100mVrms, f=1kHz unless otherwise specified)

PARAMETER	SYMBOL	TEST CONDITION	MIN.	TYP.	MAX.	UNIT
Maximum Input Voltage	V_{IMRS}	THD=5%	2.8	3.0	-	Vrms
Bypass Gain	G_{VPASSR}	SRSEL=Bypass, Lin=Rin=100mVrms	-2.0	0	2.0	dB
Voltage Gain	G_{VRS}	BCS="0", S-TRIM="0000", S-MUTE="1", f=100Hz	-2.0	0	2.0	
Maximum Gain	G_{VMAXRS}	BCS="1", S-TRIM="1111", S-MUTE="1", f=100Hz	12.5	15.0	17.5	
Minimum Gain	G_{VMINRS}	BCS="0", S-TRIM="1111", S-MUTE="1", f=100Hz	-	-15.0	-	
Mute Level	$G_{VMUTERS}$	S-MUTE="0", Rin=1Vrms, Lin=0	-	-80	-70	
Total Harmonic Distortion	THD_{RS}	BCS="0", S-TRIM="0000", S-MUTE="1", BW=400Hz to 30kHz, Rin=500mVrms, Lin=0	-	0.1	0.5	%
Output Noise 1	V_{NO1RS}	BCS="0", S-TRIM="0000", S-MUTE="1", No Signal, A-Weighted, Rg=0Ω	-	-94 (19.6)	-85 (56.2)	dBV (μVrms)
Output Noise 2	V_{NO2RS}	S-MUTE="0", No Signal, A-Weighted, Rg=0Ω	-	-106 (5.0)	-96 (15.8)	

BW: Band Width

MEASUREMENT CIRCUIT

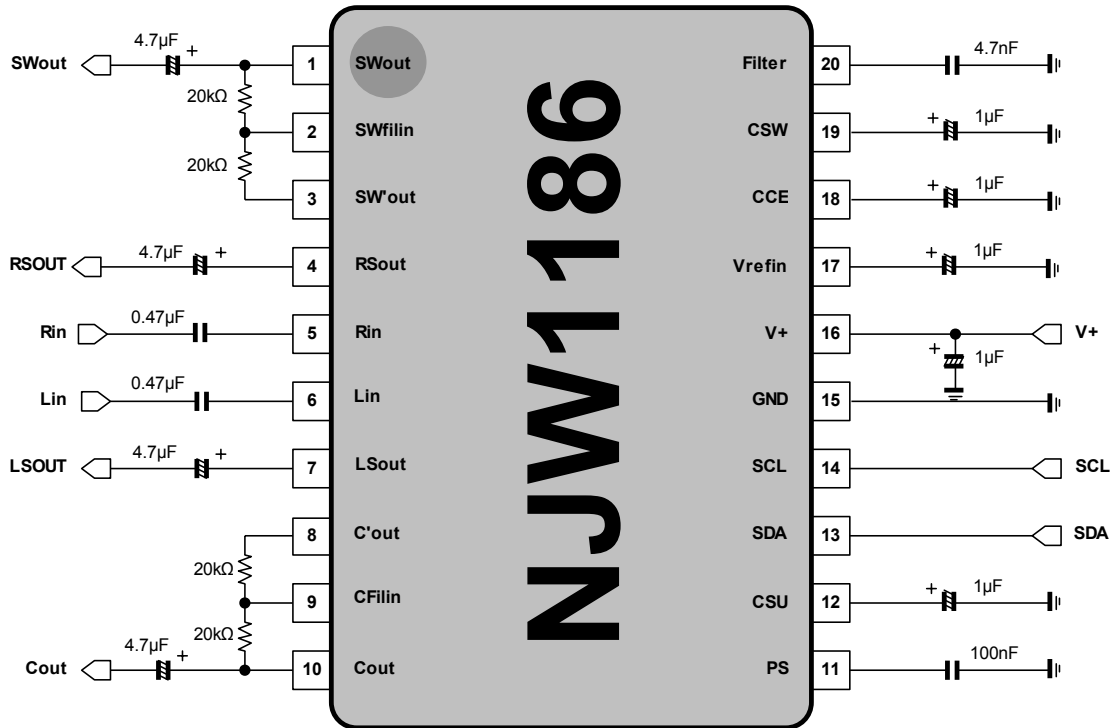

■ APPLICATION CIRCUIT 1

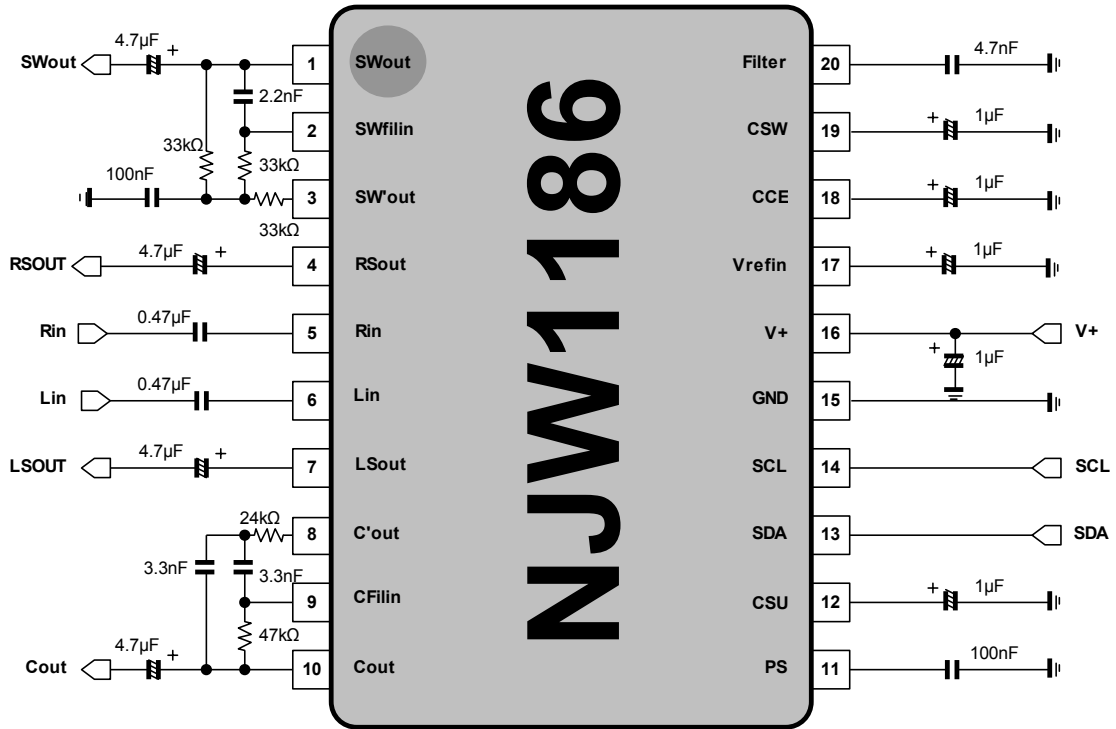

■ APPLICATION CIRCUIT 2

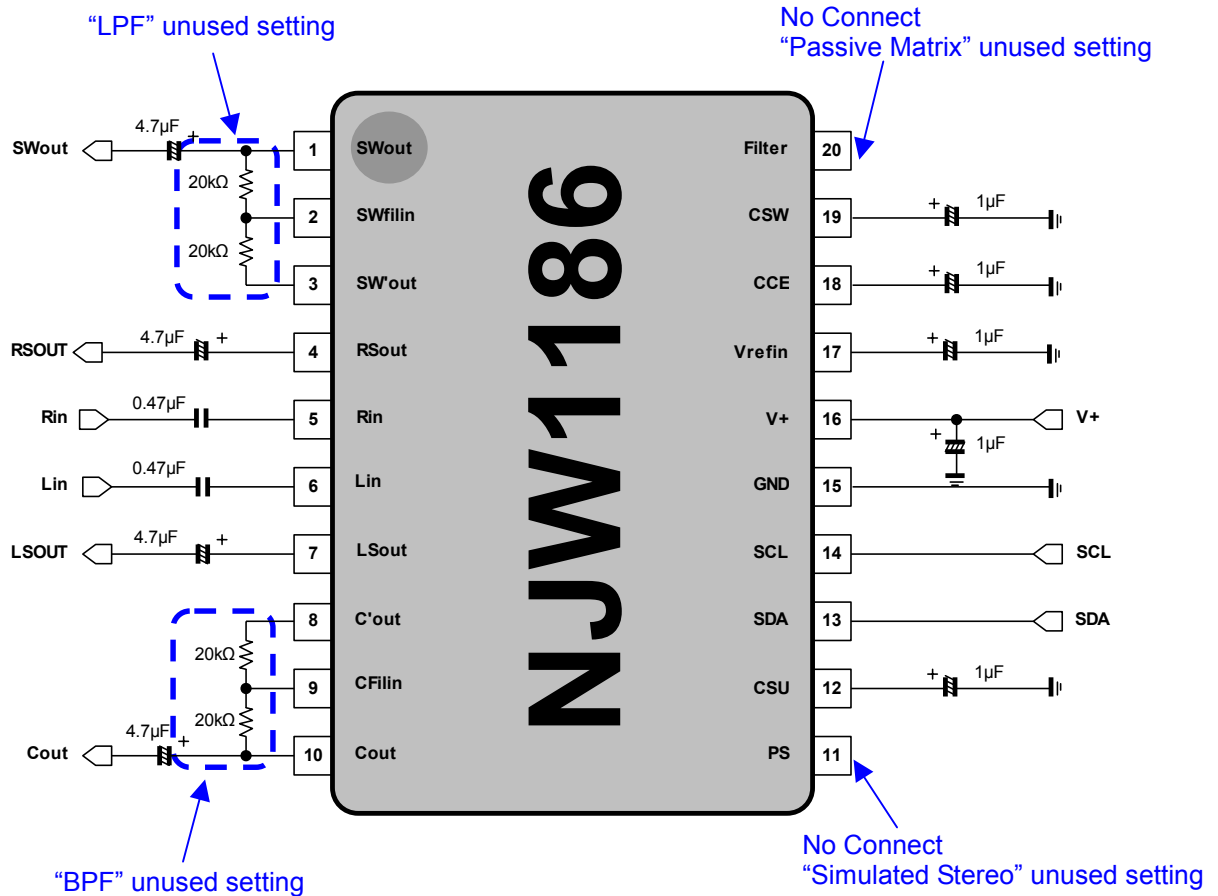

■ TERMINAL DESCRIPTION

PIN NO.	SYMBOL	FUNCTION	EQUIVALENT CIRCUIT	TERMINAL DC VOLTAGE
1 10	SWout Cout	Subwoofer Channel Output Center Channel Output		$V^+/2$
2 9	SWFilin CFilin	LPF for Subwoofer Channel LPF for Center Channel		-
3 8	SW'out C'out	Subwoofer Channel Trimmer Output Center Channel Trimmer Output		$V^+/2$
4 11 20	RSout PS Filter	Right Surround Channel Output Filter for Simulated Stereo Filter for Surround Channel		$V^+/2$

■ TERMINAL DESCRIPTION

PIN NO.	SYMBOL	FUNCTION	EQUIVALENT CIRCUIT	TERMINAL DC VOLTAGE
5 6	Rin Lin	Right Channel Input Left Channel Input		$V^+/2$
7	LSout	Left Surround Channel Output		$V^+/2$
12 18 19	CSU CCE CSW	Pop Noise Reduction for Left Surround & Right Surround Channel Trimmer Pop Noise Reduction for Center Channel Trimmer Pop Noise Reduction for Subwoofer Channel Trimmer		$V^+/2$
13 14	SDA SCL	I ² C Bus Data Input I ² C Bus Clock Input		-

■ TERMINAL DESCRIPTION

PIN NO.	SYMBOL	FUNCTION	EQUIVALENT CIRCUIT	TERMINAL DC VOLTAGE
15 16	GND V+	Ground Power Supply		-
17	Vrefin	Reference Voltage Stabilizing Capacitor		$V^+/2$

■ DEFINITION OF I²C REGISTER

● I²C BUS FORMAT

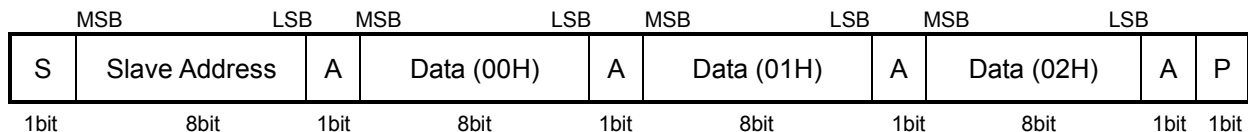

S: Starting Term
 A: Acknowledge Bit
 P: Ending Term

● SLAVE ADDRESS



R/W=0: Write mode for register setting
 R/W=1: Not available

● CONTROL REGISTER TABLE

Address	BIT								
	D7	D6	D5	D4	D3	D2	D1	D0	
00H	BCS	S-TRIM				S-MUTE	SIM	SRSEL	
01H	BCC	C-TRIM				C-MUTE	Don't Care		
02H	BCW	W-TRIM				W-MUTE	Don't Care		

● CONTROL REGISTER DEFAULT VALUE

Address	BIT							
	D7	D6	D5	D4	D3	D2	D1	D0
00H	0	0	0	0	0	0	0	0
01H	0	0	0	0	0	0	-	
02H	0	0	0	0	0	0	-	

■ I²C BUS CHARACTERISTICS (SDA, SCL)

I²C BUS Load Conditions (Standard mode): Pull up resistance 4kΩ (Connected to +5V), Load capacitance 200pF (Connected to GND)

I²C BUS Load Conditions (Fast mode): Pull up resistance 4kΩ (Connected to +5V), Load capacitance 50pF (Connected to GND)

PARAMETER	SYMBOL	Standard mode			Fast mode			UNIT
		MIN.	TYP.	MAX.	MIN.	TYP.	MAX.	
Low Level Input Voltage	V _{IL}	0.0	-	1.5	0.0	-	1.5	V
High Level Input Voltage	V _{IH}	2.7	-	5.0	2.7	-	5.0	V
Hysteresis of Schmitt trigger inputs	V _{hys}	-	-	-	0.25	-	-	V
Low level output voltage (3mA at SDA pin)	V _{OL}	0	-	0.4	0	-	0.4	V
Output fall time from V _{IHmin} to V _{ILmax} with a bus capacitance from 10pF to 400pF	t _{of}	-	-	250	20 +0.1C _b	-	250	ns
Pulse width of spikes which must be suppressed by the input filter	t _{SP}	-	-	-	0	-	50	ns
Input current each I/O pin with an input voltage between 0.1V _{DD} and 0.9V _{DDmax}	I _i	-10	-	10	-10	-	10	μA
Capacitance for each I/O pin	C _i	-	-	10	-	-	10	pF
SCL clock frequency	f _{SCL}	-	-	100	-	-	400	kHz
Hold time (repeated) START condition.	t _{HD:STA}	4.0	-	-	0.6	-	-	μs
Low period of the SCL clock	t _{LOW}	4.7	-	-	1.3	-	-	μs
High period of the SCL clock	t _{HIGH}	4.0	-	-	0.6	-	-	μs
Set-up time for a repeated START condition	t _{SU:STA}	4.7	-	-	0.6	-	-	μs
Data hold time	t _{HD:DAT}	0	-	3.45	0	-	0.9	μs
Data set-up time	t _{SU:DAT}	250	-	-	100	-	-	ns
Rise time of both SDA and SCL signals	t _r	-	-	1000	-	-	300	ns
Fall time of both SDA and SCL signals	t _f	-	-	300	-	-	300	ns
Set-up time for STOP condition	t _{SU:STO}	4.0	-	-	0.6	-	-	μs
Bus free time between a STOP and START condition	t _{BUF}	4.7	-	-	1.3	-	-	μs
Capacitive load for each bus line	C _b	-	-	400	-	-	400	pF
Noise margin at the Low level	V _{nL}	0.5	-	-	0.5	-	-	V
Noise margin at the High level	V _{nH}	1	-	-	1	-	-	V

C_b: total capacitance of one bus line in pF.

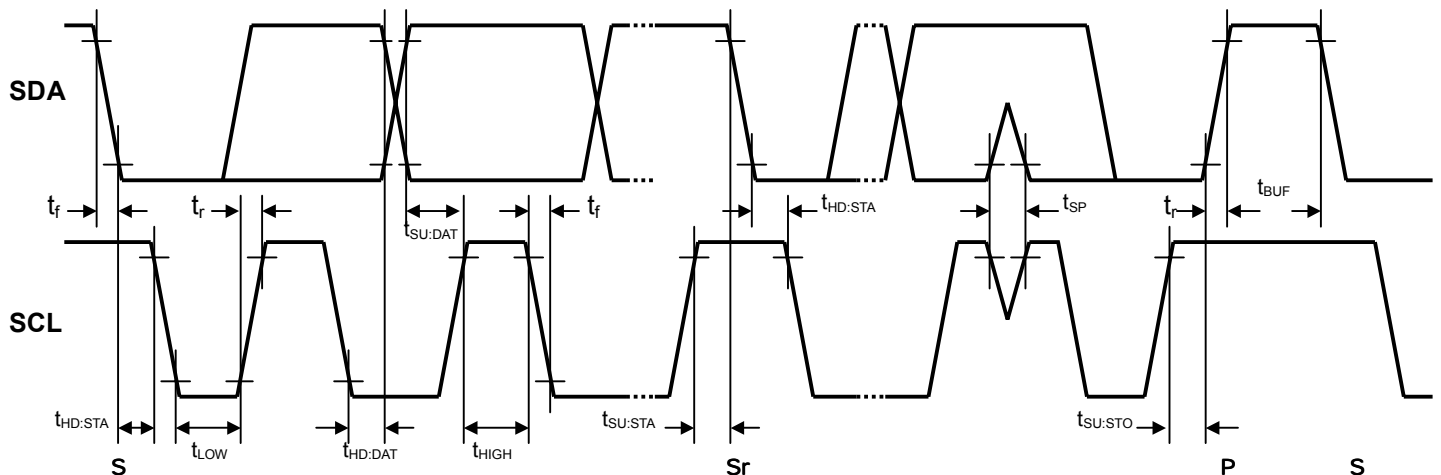

■ I²C CONTROL COMMAND DESCRIPTION

a) SURROUND CHANNEL SETTINGS

Address	BIT								
	D7	D6	D5	D4	D3	D2	D1	D0	
00H	BCS	S-TRIM				S-MUTE	SIM	SRSEL	

- BCS: Boost or Cut Select for Surround Channel Trimmer
 "0": Cut
 "1": Boost
- S-TRIM: Trimmer Level for Surround Channel
 Cut Level : -15 to 0dB(1dB/step)
 Boost Level : 0 to +15dB(1dB/step)
- S-MUTE: Mute for Surround Channel Trimmer
 "0": Mute ON
 "1": Mute OFF
- SIM: Simulated Stereo Function for Surround Channel
 "0": Normal
 "1": Wide
- SRSEL: Surround Channel Signal Selector
 "0": Bypass (The output signal as same as L/Rch input signal.)
 "1": Surround Settings

b) CENTER CHANNEL SETTINGS

Address	BIT								
	D7	D6	D5	D4	D3	D2	D1	D0	
01H	BCC	C-TRIM				C-MUTE	Don't Care		

- BCC: Boost or Cut Select for Center Channel Trimmer
 "0": Cut
 "1": Boost
- C-TRIM: Trimmer Level for Center Channel
 Cut Level : -15 to 0dB(1dB/step)
 Boost Level : 0 to +15dB(1dB/step)
- C-MUTE: Mute for Center Channel Trimmer
 "0": Mute ON
 "1": Mute OFF

c) SUBWOOFER CHANNEL SETTINGS

Address	BIT								
	D7	D6	D5	D4	D3	D2	D1	D0	
02H	BCW	W-TRIM				W-MUTE	Don't Care		

- BCW: Boost or Cut Select for Subwoofer Channel Trimmer
 "0": Cut
 "1": Boost
- W-TRIM: Trimmer Level for Subwoofer Channel
 Cut Level : -15 to 0dB(1dB/step)
 Boost Level : 0 to +15dB(1dB/step)
- W-MUTE: Mute for Subwoofer Channel Trimmer
 "0": Mute ON
 "1": Mute OFF

■ SURROUND CHANNEL TRIMMER SETTINGS (Address: 00H)

Trimmer Cut or Boost	BCS
	D7
Cut	0
Boost	1

		S-TRIM			
Cut Gain(dB)	Boost Gain(dB)	D6	D5	D4	D3
-15	15	1	1	1	1
-14	14	1	1	1	0
-13	13	1	1	0	1
-12	12	1	1	0	0
-11	11	1	0	1	1
-10	10	1	0	1	0
-9	9	1	0	0	1
-8	8	1	0	0	0
-7	7	0	1	1	1
-6	6	0	1	1	0
-5	5	0	1	0	1
-4	4	0	1	0	0
-3	3	0	0	1	1
-2	2	0	0	1	0
-1	1	0	0	0	1
0	0	0	0	0	0

■ CENTER CHANNEL TRIMMER SETTINGS (Address: 01H)

Trimmer Cut or Boost	BCC
	D7
Cut	0
Boost	1

		C-TRIM			
Cut Gain(dB)	Boost Gain(dB)	D6	D5	D4	D3
-15	15	1	1	1	1
-14	14	1	1	1	0
-13	13	1	1	0	1
-12	12	1	1	0	0
-11	11	1	0	1	1
-10	10	1	0	1	0
-9	9	1	0	0	1
-8	8	1	0	0	0
-7	7	0	1	1	1
-6	6	0	1	1	0
-5	5	0	1	0	1
-4	4	0	1	0	0
-3	3	0	0	1	1
-2	2	0	0	1	0
-1	1	0	0	0	1
0	0	0	0	0	0

■ SUBWOOWER CHANNEL TRIMMER SETTINGS (Address: 02H)

Trimmer Cut or Boost	BCW D7
Cut	0
Boost	1

		W-TRIM			
Cut Gain(dB)	Boost Gain(dB)	D6	D5	D4	D3
-15	15	1	1	1	1
-14	14	1	1	1	0
-13	13	1	1	0	1
-12	12	1	1	0	0
-11	11	1	0	1	1
-10	10	1	0	1	0
-9	9	1	0	0	1
-8	8	1	0	0	0
-7	7	0	1	1	1
-6	6	0	1	1	0
-5	5	0	1	0	1
-4	4	0	1	0	0
-3	3	0	0	1	1
-2	2	0	0	1	0
-1	1	0	0	0	1
0	0	0	0	0	0

[CAUTION]

The specifications on this databook are only given for information, without any guarantee as regards either mistakes or omissions. The application circuits in this databook are described only to show representative usages of the product and not intended for the guarantee or permission of any right including the industrial rights.