

FAN8741/FAN8742

Spindle motor and 6-CH actuator driver

[Spindle(PWM), Sled 2-CH(PWM) 4-CH(Linear)]

FAN8741 Features

Common

- Built-in thermal shutdown circuit (TSD)
- 8 Independent voltage sources
- Corresponds to 3.3V or 5V DSP
- 4 selectable mute

Spindle

- Output PWM mode control
- FG output: open collector type
- Selectable brake(short & reverse brake)
- Built in hall bias
- 180° commutation(compatible with conventional BLDC spindle motor)
- Built in arm short preventer

BTL(Sled 2-channels)

- Output PWM mode control
- Built in arm short preventer

BTL(Other 4-channels)

- Output LINEAR mode control

Typical Applications

- Compact disk ROM (CD-ROM)
- Compact disk RW (CD-RW)
- Digital video disk ROM (DVD-ROM)
- Digital video disk RAM (DVD-RAM)
- Digital video disk Player (DVDP)
- Other compact disk media
- Game console

Description

The FAN8741G/FAN8742G is a monolithic IC suitable for a 3-phase BLDC(Brush Less Direct Current) spindle motor driver with PWM, 2-ch motor drivers with PWM for sled motor and 4-ch linear drivers which drive the focus actuator, tracking actuator, tilt actuator and loading motor of the optical media applications. Since FAN8741G/FAN8742G aims to high-speed/high-density optical media applications its power stage is made by D-MOS transistors which have extremely low RDS on. This enables less heat generation and guarantees more reliable lifetime.



Ordering Information

Device	Package	Operating Temp.
FAN8741G	56-SSOP	-25°C ~ +75°C
FAN8741GX	56-SSOP	-25°C ~ +75°C
FAN8742G	56-SSOP	-25°C ~ +75°C
FAN8742GX	56-SSOP	-25°C ~ +75°C

X:Tape & Reel type

FAN8741G:FG3X

FAN8742G:FG1X

Pin Assignments

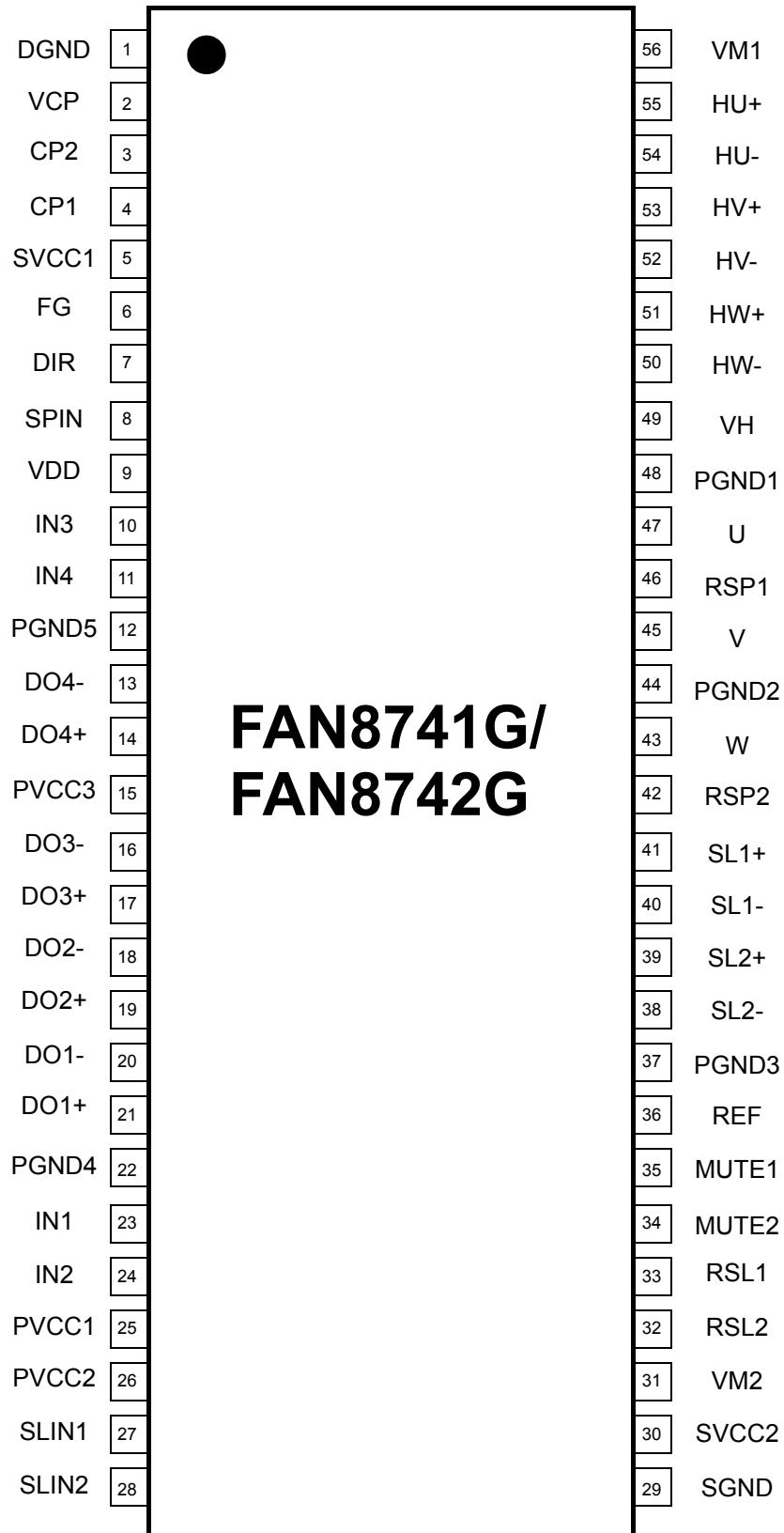

Pin Definitions(continued)

Pin Number	Pin Name	I/O	Pin Function Description
29	SGND	P	Signal ground for BTL signal block
30	SVCC2	P	Power supply for BTL Pre driver
31	VM2	P	Power supply for sled
32	RSL2	A	Sled current sensing 2
33	RSL1	A	Sled current sensing 1
34	MUTE2	A	Mute input 2
35	MUTE1	A	Mute input 1
36	REF	A	Reference voltage input
37	PGND3	P	Power ground for sled channels
38	SL2-	A	Sled channel 2 drive output -
39	SL2+	A	Sled channel 2 drive output +
40	SL1-	A	Sled channel 1 drive output -
41	SL1+	A	Sled channel 1 drive output +
42	RSP2	A	Spindle current sensing 2
43	W	A	3-phase output W for spindle
44	PGND2	P	Power ground 2 for spindle channel
45	V	A	3-phase output V for spindle
46	RSP1	A	Spindle current sensing 1
47	U	A	3-phase output U for spindle
48	PGND1	P	Power ground 1 for spindle channel
49	VH	A	Hall bias
50	HW-	A	Hall signal input(Hw-)
51	HW+	A	Hall signal input(Hw+)
52	HV-	A	Hall signal input(Hv-)
53	HV+	A	Hall signal input(Hv+)
54	HU-	A	Hall signal input(Hu-)
55	HU+	A	Hall signal input(Hu+)
56	VM1	P	Power supply for spindle

Internal Block Diagram

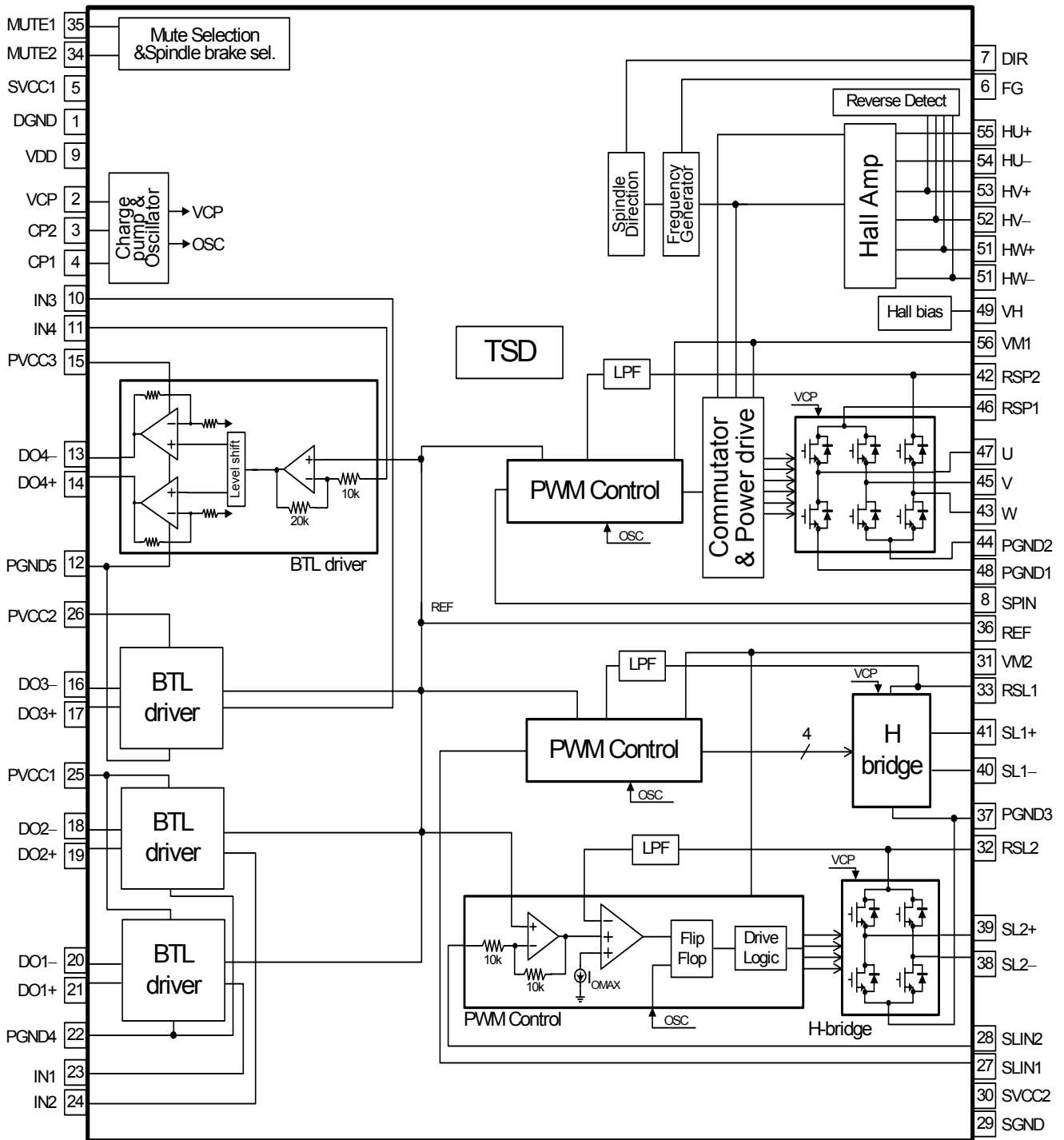

Equivalent Circuits

Charge Pump Outputs	FG/DIR Outputs
Spin Input	Hall Inputs
Hall Bias Input	Mute1 & 2 Inputs
Spindle Drive Outputs	Spindle Current Sensing Input

Equivalent Circuits(continued)

Sled 1 & 2 Inputs	Sled Drive Outputs
CH1/2/3/4(BTL Channels) Inputs	Sled 1 & 2 Current Sensing Inputs
Reference Input	CH4 Outputs
CH3 Outputs	CH1 & 2 Outputs

Absolute Maximum Ratings (Ta = 25°C)

Parameter	Symbol	Value	Unit
Supply Voltage (Signal block)	SVCC1max	7	V
Supply Voltage (Digital block)	VDDmax	7	V
Supply Voltage (Spindle driver)	VM1max	15	V
Supply Voltage (Sled driver)	VM2max	15	V
Supply Voltage (BTL driver)	PVCC1,2,3max	15	V
Supply Voltage (BTL Pre driver)	SVCC2max	15	V
Power dissipation	P _D	3.1/4.7	W
Operating Temperature Range	T _{OPR}	-20 ~ +75	°C
Storage temperature Range	T _{STG}	-40 ~ +150	°C
Maximum Output Current (Spindle)	I _{Omax1}	2.0	A
Maximum Output Current(CH1/2/3/4)	I _{Omax2}	1.0	A
Maximum Output Current (Sled)	I _{Omax3}	1.0	A

NOTE:

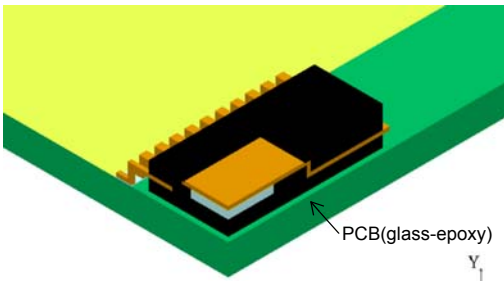
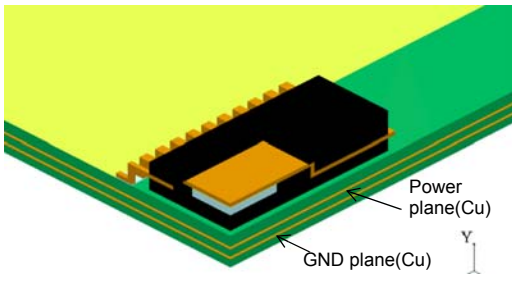
Case 1	Case 2	Remark
		Pd is measured base on the JEDEC/STD(JESD 51-2)
Pd=3.1W	Pd=4.7W	

- Case 1: Single layer PCB with 1 signal plane only, PCB size is 76mm × 114mm × 1.6mm.
- Case 2: Multi layer PCB with 1 signal, 1 power and 1 ground planes, PCB size is 76mm × 114mm × 1.6mm, Cu plane sizes for power and ground is 74mm × 62mm × 0.035mm.
- These are simulation datum.
- Power dissipation is reduced by -24.8mW/°C for using above Ta=25°C in case 1.
- Power dissipation is reduced by -37.6mW/°C for using above Ta=25°C in case 2.
- Do not exceed P_D and SOA (Safe Operating Area).

Power Dissipation Curve

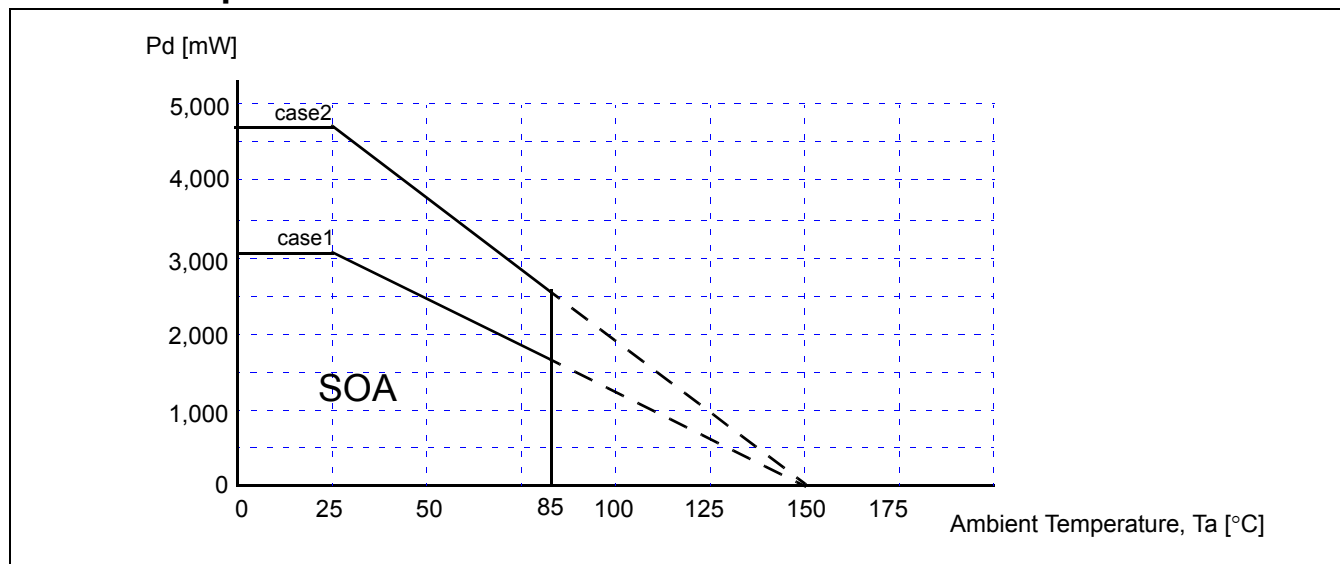

Recommended Operating Conditions (Ta = 25°C)

Parameter	Symbol	Min.	Typ.	Max.	Unit
Supply Voltage (Spindle Signal block)	SVCC1	4.5	5	5.5	V
Supply Voltage (Digital block)	VDD	4.5	5	5.5	V
Supply Voltage (Spindle driver)	VM1	4.5	12	13.2	V
Supply Voltage (Sled driver)	VM2	4.5	12	13.2	V
Supply Voltage (BTL driver)	PVCC1,2,3	4.5	12	SVCC2	V
Supply Voltage (BTL signal block)	SVCC2	4.5	12	13.2	V
Output current(Spindle)	IO1	-	1.0	1.5	A
Output current(Focus, Tracking, Loading)	IO2	-	0.5	0.8	A
Output current(Sled)	IO3	-	0.5	0.8	A

ELECTRICAL CHARACTERISTICS (Ta = 25°C)

(Ta=25°C, SVCC1=VDD=PVCC1=VM2=5V,VM1=SVCC2=PVCC2=PVCC3=12V unless otherwise noted)

Parameter	Symbol	Condition	Min.	Typ.	Max.	Units
COMMON PART						
Quiescent Circuit Current 1	ISVCC1	Mute1=L, Mute2=L	-	1	-	mA
	ISVCC2		-	1	-	
Quiescent Circuit Current 2	ISVCC1	Mute1=L, Mute2=H	-	1.5	-	mA
	ISVCC2		-	9.5	-	
Quiescent Circuit Current 3	ISVCC1	Mute1=H, Mute2=H	-	4	-	mA
	ISVCC2		-	13	-	
Mute Low Voltage	V _{MLOW}	MUTE=variation	-	-	0.8	V
Mute High Voltage	V _{MHIGH}	MUTE=variation	3.0	-	-	V
Mute Input Current	I _{MUTEIN}	MUTE=5V	-	130	-	μA
Charge Pump Voltage 1	V _{PUMP1}	I _{PUMP} =0mA	-	19	-	V
Charge Pump Voltage 2	V _{PUMP2}	I _{PUMP} =-1mA	-	18	-	V
THERMAL SHUTDOWN						
Operating Temperature*	T _{TSD}		-	150	-	C
Hysteresis Temperature*	T _{HYS}		-	25	-	C
SPINDLE DRIVE PART						
Control Input Deadzone11	V _{DZSPF}	SPIN>VREF	20	50	100	mV
Control Input Deadzone12	V _{DZSPR}	SPIN<VREF	-100	-50	-20	mV
Control Voltage Input Range	V _{INSP}		0	-	5	V
Output Gain	G _{MSP}	G _{MSP} =G _{VO} /R _{CSSP} , R _{CSSP} =0.33Ω, G _{VO} =1[V/V]	2.55	3.0	3.45	A/V
Output On Resistance(upper)	R _{ONUSP}	I _o =500mA	-	0.4	-	Ω
Output On Resistance(lower)	R _{ONLSP}	I _o =500mA	-	0.4	-	Ω
Output Limit Current	I _{LIMITSP}	R _{CSSP} =0.33Ω	-	1.5	-	A
Hall Amp Common Mode Input Range	V _{HCOM}	-	1	-	4	V
Minimum Hall Input Level*	V _{HMIN}	-	50	-	-	mV
Hall Bias Output Voltage	V _{HB}	I _{HB} =10mA	0.5	1.0	1.5	V
Hall Bias Input Current	I _{VH}		-	1	5	μA
FG Low Voltage	V _{FGL}	I _{FG} =3mA	-	-	0.5	V
DIR Low Voltage	V _{DIRL}	I _{DIR} =3mA	-	-	0.5	V
SLED DRIVE PART						
Control Input Deadzone21	V _{DZSLF}	SLIN1/SLIN2 > VREF	0	15	30	mV
Control Input Deadzone22	V _{DZSLR}	SLIN1/SLIN2 < VREF	-30	-15	0	mV
Output Gain	G _{MSL}	G _{MSL} =G _{VO} /R _{CSSL} , R _{CSSL} =1Ω, G _{VO} =1[V/V]	0.85	1.0	1.15	A/V
Output On Resistance(upper)	R _{ONUSL}	I _o =250mA	-	1.0	-	Ω
Output On Resistance(lower)	R _{ONLSL}	I _o =250mA	-	1.0	-	Ω
Output Limit Current	I _{LIMITSL}	R _{CSSL} =1Ω	-	0.5	-	A

* : Design guarantee specification

ELECTRICAL CHARACTERISTICS (Ta = 25°C, continued)

(Ta=25°C, SVCC1=VDD=PVCC1=VM2=5V,VM1=SVCC2=PVCC2=PVCC3=12V unless otherwise noted)

Parameter	Symbol	Condition	Min.	Typ.	Max.	Units
CH1,CH2 DRIVE PART (TYPICALLY ACTUATOR DRIVER)						
Output Saturation Voltage H	V _{OHFT12}	I _O =500mA		0.5		V
Output Saturation Voltage L	V _{OLFT12}	I _O =500mA		0.5		V
Closed Loop Voltage Gain	G _{VFT12}	-	16.5	18	19.5	dB
Output Offset Voltage	V _{OFFT12}	VREF=IN1=IN2=1.65V	-50	-	50	mV
CH3,CH4 DRIVE PART (TYPICALLY TILT,LOADING DRIVER)						
Output Saturation Voltage H	V _{OHFT34}	I _O =500mA		1.0		V
Output Saturation Voltage L	V _{OLFT34}	I _O =500mA		0.5		V
Closed Loop Voltage Gain	G _{VFT34}	-	16.5	18	19.5	dB
Output Offset Voltage	V _{OFFT34}	VREF=IN3=IN4=1.65V	-50	-	50	mV
CH1,CH3 GAIN DIFFERENCE SPEC (TYPICALLY FOCUS,TILT DRIVER)						
CH1-CH3 Gain Difference	G _{1TO3}	G _{VFT12} - G _{VFT34}	-0.5	0	0.5	dB

Application Information

1. TORQUE CONTROL & OUTPUT CURRENT CONTROL OF 3-PHASE BLDC MOTOR

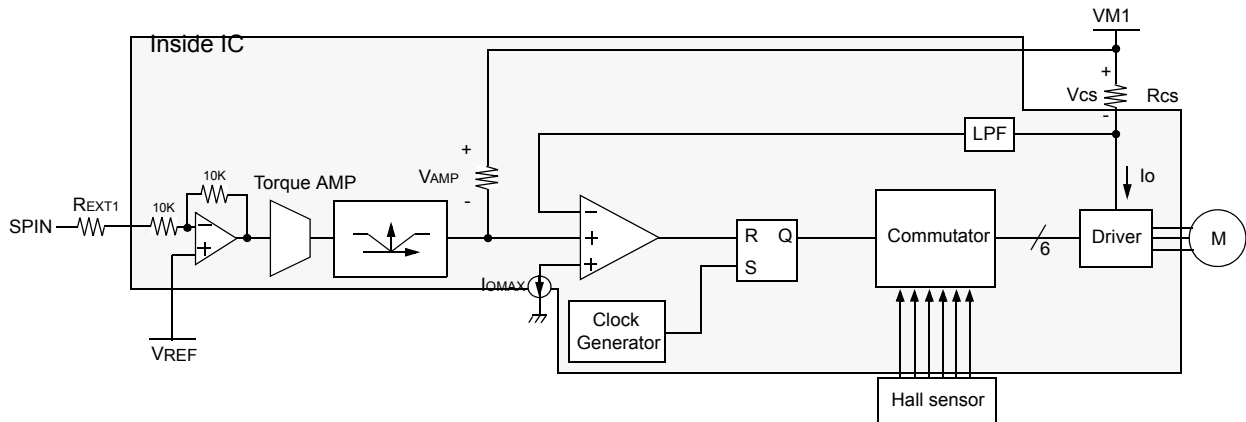

- 1) By amplifying the voltage difference between VREF and SPIN from Servo IC(or DSP), the Torque AMP produces the input voltage(VAMP) which means input current command.
- 2) The output current (IO) is converted into the voltage (VCS) through the sense resistor (RCS) and compared with the VAMP.
- 3) The clock generator always make the RS latch become set periodically, this enables output driver on state and when the VCS and the VAMP is equal the state becomes off.
- 4) By the negative feedback loop, the sensed output voltage VCS equals to the VAMP.
- 5) Commuting sequence is selected by hall sensor input, and the minimum hall input is 50mV.
- 6) The gain and limit current is calculated as below table.($G_{VO} = V_{AMP} / (SPIN - V_{REF}) = 1 [V/V]$).

Limit current	Input/Output gain[A/V]	Remark
$\frac{0.5}{R_{CS}}$	$\frac{10K}{R_{EXT1} + 10K} \cdot \frac{G_{VO}}{R_{CS}}$	$\frac{10K}{R_{EXT1} + 10K}$ is gain scaler

- 7) Spindle block adopts 180° commutation methodology which is full compatible with conventional BLDC spindle motor. Users don't need to change or modify their spindle motor.
- 8) The range of the input voltage is as shown below when $R_{CS} = 0.33\Omega$, $R_{EXT1} = 0$.

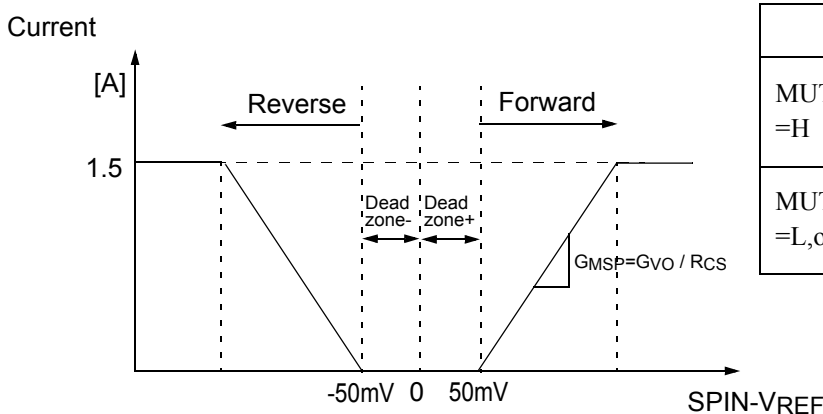

		Rotation
MUTE2 =H	SPIN > VREF	Forward rotation
	SPIN < VREF	Reverse brake
MUTE2 =L,open	SPIN ≠ VREF	Short brake
		Short brake

The input range of SPIN is 0 V ~ 5 V

2. TORQUE CONTROL & OUTPUT CURRENT CONTROL OF SLED MOTOR(2-PHASE STEP MOTOR)

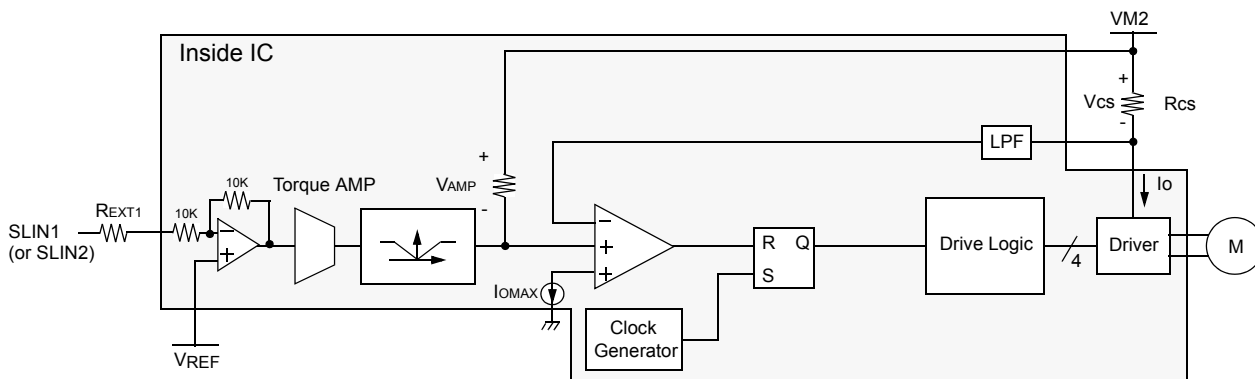

- 1) By amplifying the voltage difference between VREF and SLIN1(or SLIN2) from Servo IC(or DSP), the Torque AMP produces the input voltage(VAMP) which means input current command.
- 2) The output current (IO) is converted into the voltage (VCS) through the sense resistor (RCS) and compared with the VAMP.
- 3) The clock generator always make the RS latch become set periodically, this enables output driver on state and when the VCS and the VAMP is equal the state becomes off.
- 4) By the negative feedback loop, the sensed output voltage VCS equals to the VAMP.
- 5) To avoid output upper and lower transistor's short through, switch trick is needed. Turn on delay time is 1usec, so the phase delay time,when change the current direction is 1usec.
- 6) The gain and limit current is calculated as below table.($G_{VO} = V_{AMP} / [SLIN1(or SLIN2) - V_{REF}] = 1[V/V]$)

Torque limit current	Input/Output gain[A/V]	Remark
$\frac{0.5}{R_{CS}}$	$\frac{10K}{R_{EXT1} + 10K} \cdot \frac{G_{VO}}{R_{CS}}$	$\frac{10K}{R_{EXT1} + 10K}$ is gain scaler

8) The range of the torque voltage is as shown below when $R_{CS}=1\Omega$, $R_{EXT1}=0$.

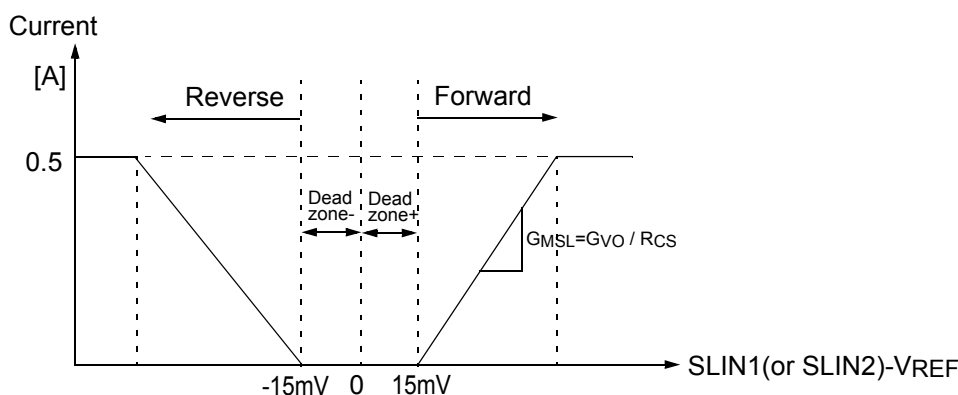

3. CHANNEL 1~4 SCHEMATIC

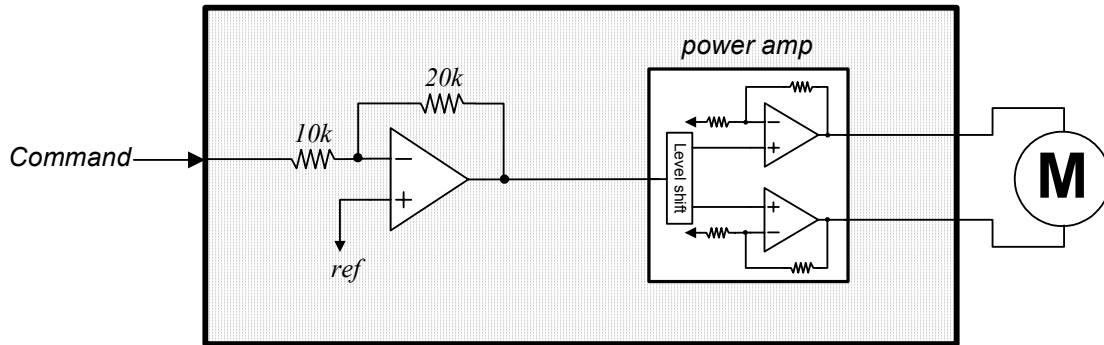

- The reference voltage(ref) is given externally through pin36.
- The input OP-amp output signal is amplified by (20K/10K) times and then fed to the power amplifier. The gain of power amplifier is 4 so the total max gain of channel 1~4 is 8.

4. MUTE INPUTS

FAN8741 has 2 independent mute pins those are, pin #14(MUTE1) and pin #13(MUTE2). Detailed logics are as below.

MUTE1	MUTE2	SPINDLE	SLED	CH1/2/3	CH4(typ. loading driver)	SPINDLE brake type
H	H	Enable			Disable	Reverse brake when SPIN<VREF
H	L	Enable			Disable	Short brake SPIN ≠ VREF ^(note)
L	H	Disable	Enable	Disable	Enable	-
L	L	Disable				-

(Note)

To make spindle short brake, MUTE2 goes low and spindle command must not be in deadzone(±50mV). When the spindle command is within deadzone, spindle block goes to disable mode even though MUTE2 is low.

5. REVERSE ROTATION PREVENTION(SPINDLE)

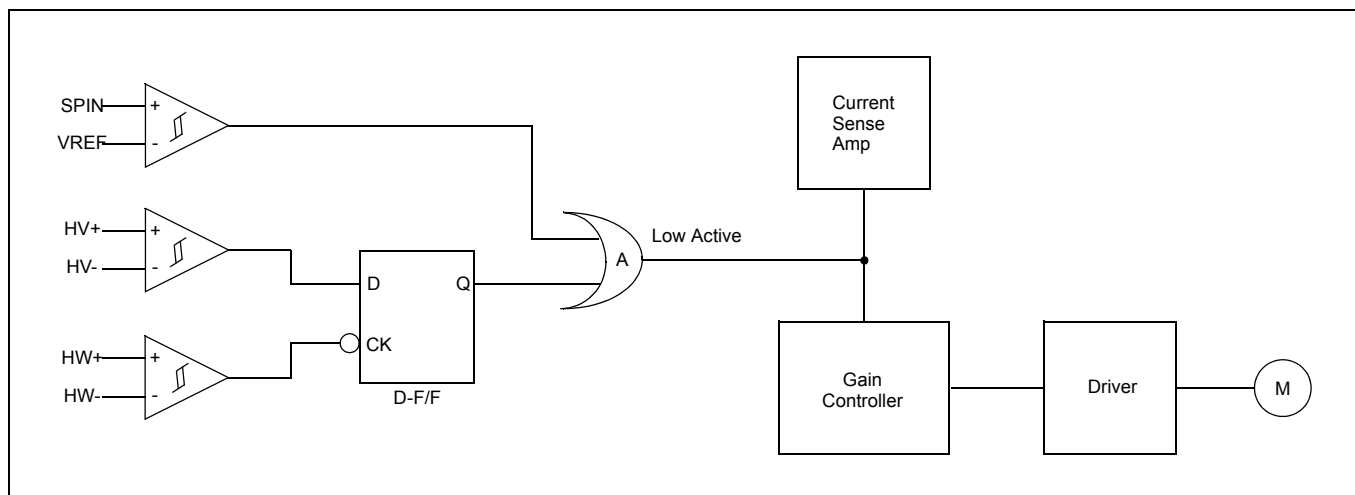

1) As in the state of the forward rotation, the D-F/F output, Q is HIGH and the motor rotates normally. At this state, if the control input is changed such that $VREF > SPIN$, then the motor rotates slowly by the reverse commutation in the Driver. When the motor rotates in reverse direction, the D-F/F output becomes Low and the OR Gate output, becomes LOW. This prevents the motor from rotating in reverse direction. The operation principle is shown in the table and the flow chart.

Rotation	HV	HW	D-F/F (Q)	Reverse Rotation Preventer	
				$VREF < SPIN$	$VREF > SPIN$
Forward	H	H→L	H	Forward	-
Reverse	L	H→L	L	-	Brake and Stop

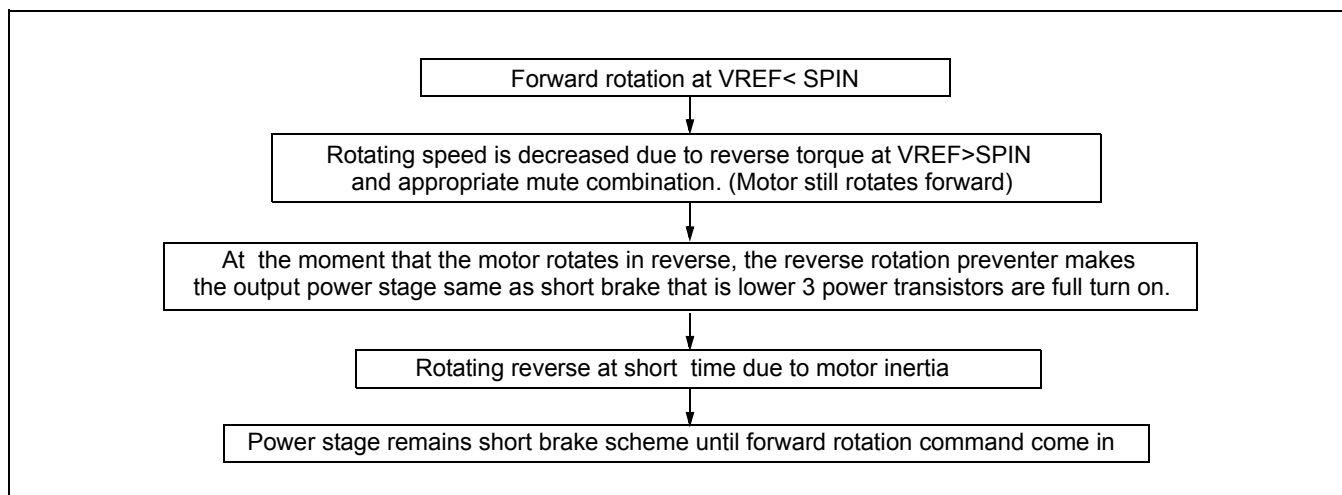

6. HALL SENSOR CONNECTION

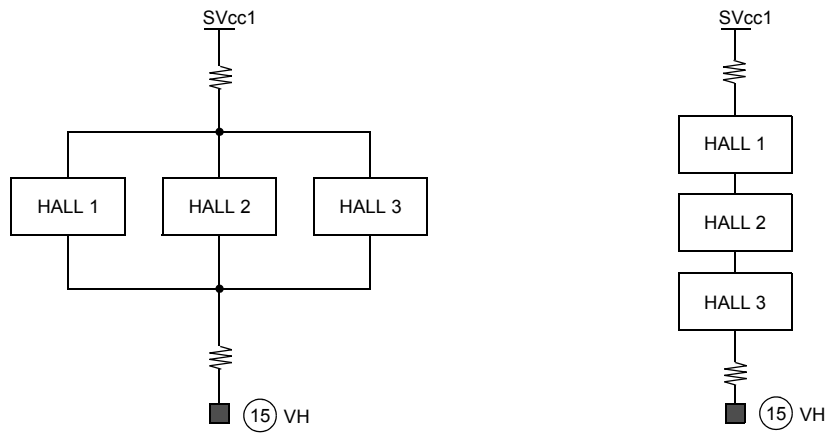

7. PWM FREQUENCY

PWM operation of spindle and sled channels are controlled by internal clock generator. Its typical frequency is 100KHz.

8. ETC

- 1) FG, DIR output are open-collector type.
- 2) By-pass capacitors are recommended at hall sensor inputs, power supply inputs.

9. SPINDLE PART INPUT-OUTPUT TIMING CHART

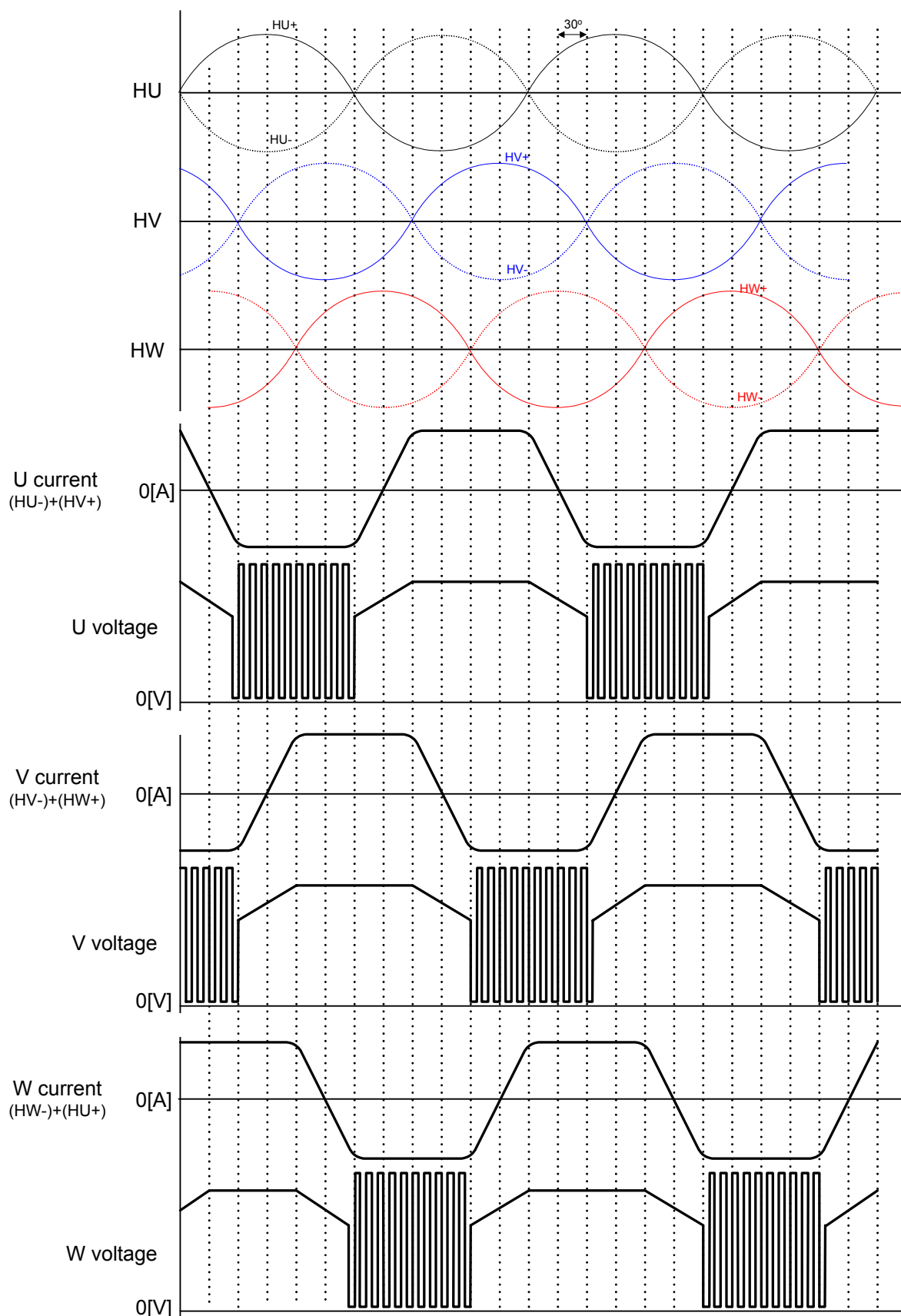

Typical Application Circuits

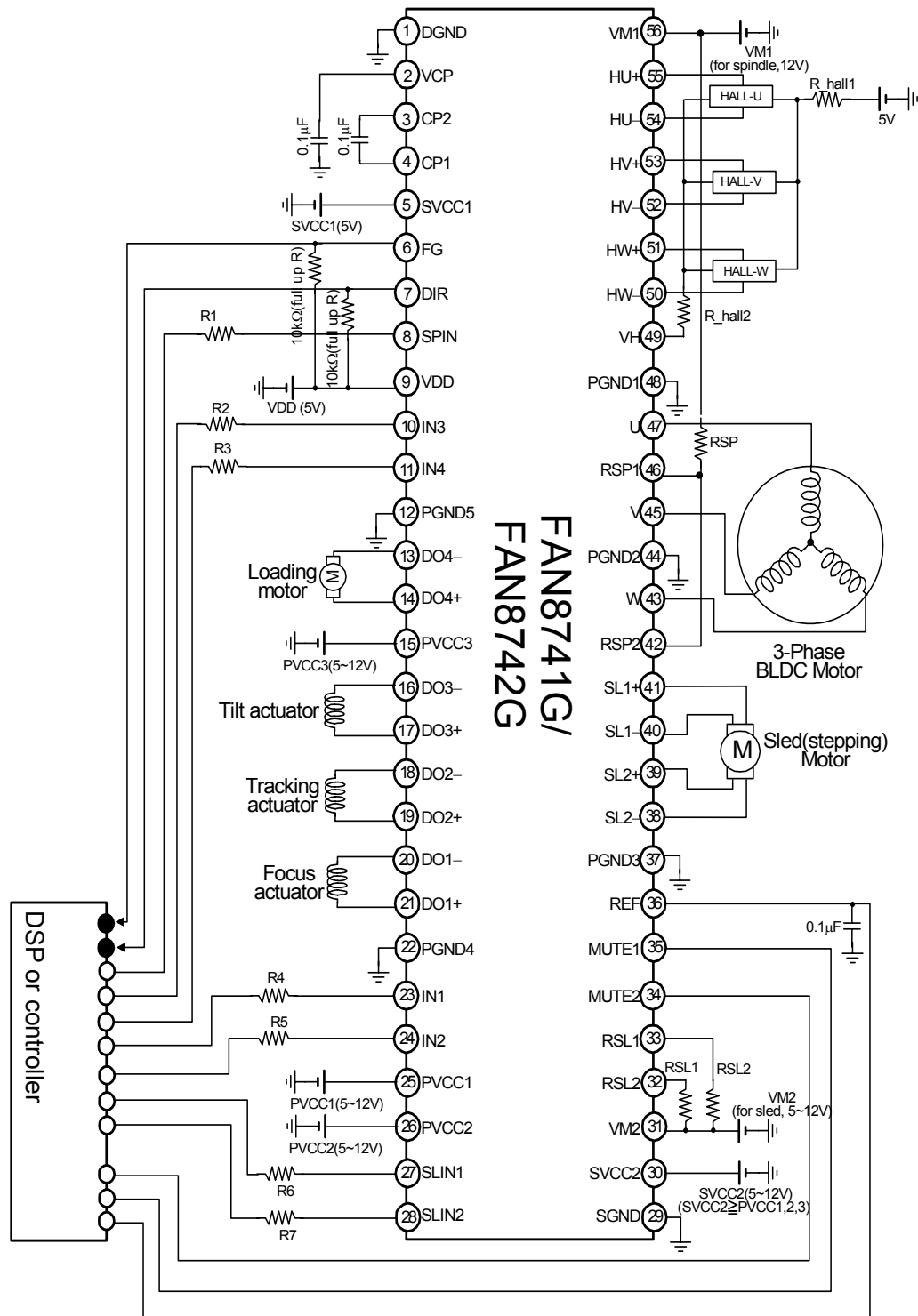

Component	Reference value	Remark
R1~R7	10kΩ	Gain scaling resistors. Please refer to 12,13,14 pages.
R_hall1,R_hall2	100Ω	Hall bias resistors
RSL1,RSL2	1Ω	Rcs at sled driver. (I_limit=0.5A,Gain=0.5A/V@R6,R7 are 10kΩ)
RSP	0.33Ω	Rcs at spindle driver. (I_limit=1.5A,Gain=1.5A/V@R1 is 10kΩ)
Bypass electrolytic capacitors(47~100μF) are recommended at power supply inputs.		

Package Dimension(exposed area is exposed to the top)

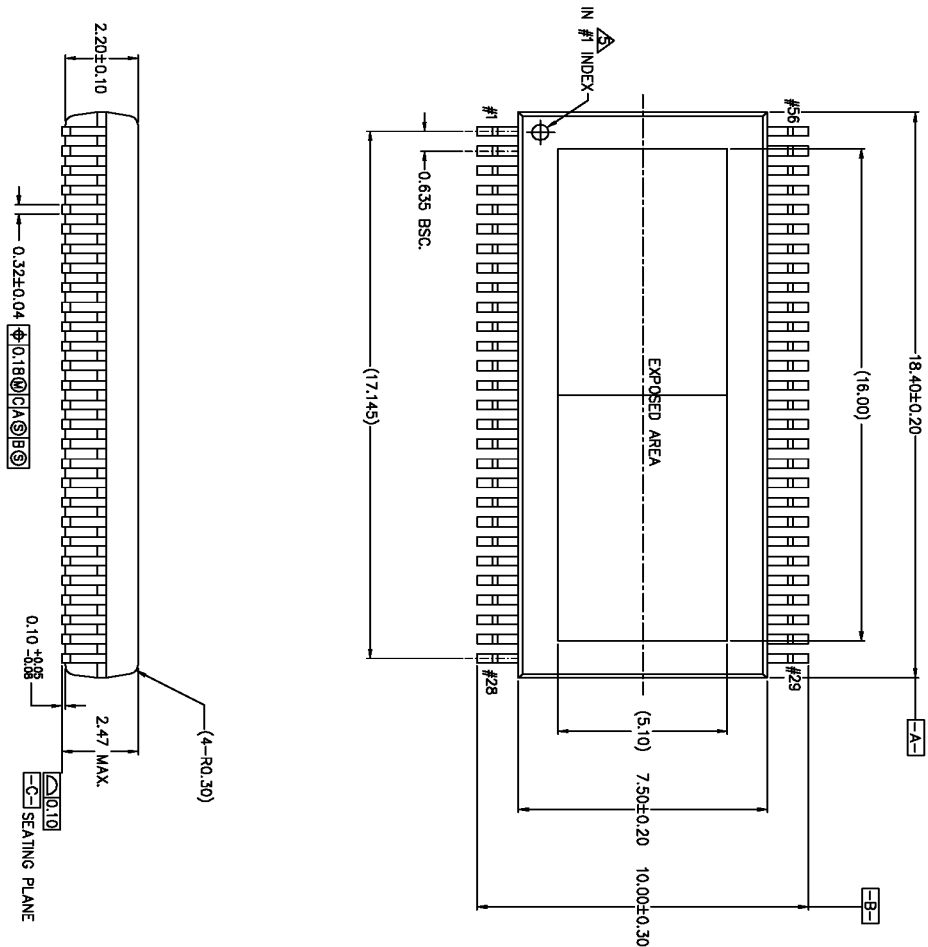

NOTE :

1. CONTROLLING DIMENSIONS ARE MM. () IS REFERENCE.
 2. DIMENSIONING AND TOLERANCING PER ANSI Y 14.5M - 1982.
 3. "A" AND "B" ARE REFERENCE DATUMS ON THE MOLDED BODY AND DO NOT INCLUDE MOLD FLASH/PROTRUSIONS. MOLD FLASH/PROTRUSIONS AT "A" SHALL NOT EXCEED 0.152MM(0.00 PER SIDE. INTER-LEAD FLASH/PROTRUSIONS AT "B" SHALL NOT EXCEED 0.254MM(0.010") PER SIDE.
 4. PIN NUMBERS START WITH PIN #1 AND CONTINUE COUNTERCLOCKWISE PIN #56 WHEN VIEWED FROM TOP.
- ∇ PIN #1 INDEX MUST BE INDENTIFIED BY LASER MARK.

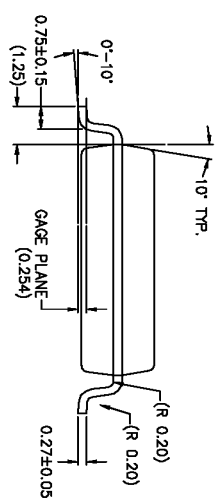

DISCLAIMER

FAIRCHILD SEMICONDUCTOR RESERVES THE RIGHT TO MAKE CHANGES WITHOUT FURTHER NOTICE TO ANY PRODUCTS HEREIN TO IMPROVE RELIABILITY, FUNCTION OR DESIGN. FAIRCHILD DOES NOT ASSUME ANY LIABILITY ARISING OUT OF THE APPLICATION OR USE OF ANY PRODUCT OR CIRCUIT DESCRIBED HEREIN; NEITHER DOES IT CONVEY ANY LICENSE UNDER ITS PATENT RIGHTS, NOR THE RIGHTS OF OTHERS.

LIFE SUPPORT POLICY

FAIRCHILD'S PRODUCTS ARE NOT AUTHORIZED FOR USE AS CRITICAL COMPONENTS IN LIFE SUPPORT DEVICES OR SYSTEMS WITHOUT THE EXPRESS WRITTEN APPROVAL OF THE PRESIDENT OF FAIRCHILD SEMICONDUCTOR CORPORATION. As used herein:

1. Life support devices or systems are devices or systems which, (a) are intended for surgical implant into the body, or (b) support or sustain life, and (c) whose failure to perform when properly used in accordance with instructions for use provided in the labeling, can be reasonably expected to result in a significant injury of the user.
2. A critical component in any component of a life support device or system whose failure to perform can be reasonably expected to cause the failure of the life support device or system, or to affect its safety or effectiveness.