



# FAST CMOS 16-BIT REGISTERED TRANSCEIVER

**IDT74FCT16952AT/CT/ET**

## FEATURES:

- 0.5 MICRON CMOS Technology
- High-speed, low-power CMOS replacement for ABT functions
- Typical  $t_{SK(o)}$  (Output Skew) < 250ps
- Low input and output leakage  $\leq 1\mu A$  (max.)
- High drive outputs (-32mA IOH, 64mA IOL)
- Power off disable outputs permit "live insertion"
- Typical VOLP (Output Ground Bounce) < 1.0V at  $V_{CC} = 5V$ ,  $T_A = 25^\circ C$
- Available in SSOP and TSSOP packages

## DESCRIPTION:

The FCT16952T 16-bit registered transceiver is built using advanced dual metal CMOS technology. These high-speed, low-power devices are organized as two independent 8-bit D-type registered transceivers with separate input and output control for independent control of data flow in either direction. For example, the A-to-B Enable ( $\overline{xCEAB}$ ) must be low to enter data from the A port.  $xCLKAB$  controls the clocking function. When  $xCLKAB$  toggles from low-to-high, the data present on the A port will be clocked into the register.  $\overline{xOEAB}$  performs the output enable function on the B port. Data flow from the B port to A port is similar but requires using  $\overline{xCEBA}$ ,  $xCLKBA$ , and  $\overline{xOEBA}$  inputs. Full 16-bit operation is achieved by tying the control pins of the independent transceivers together.

The FCT16952T is ideally suited for driving high-capacitance loads and low-impedance backplanes. The output buffers are designed with power off disable capability allowing "live insertion" of boards when used as backplane drivers.

## FUNCTIONAL BLOCK DIAGRAM

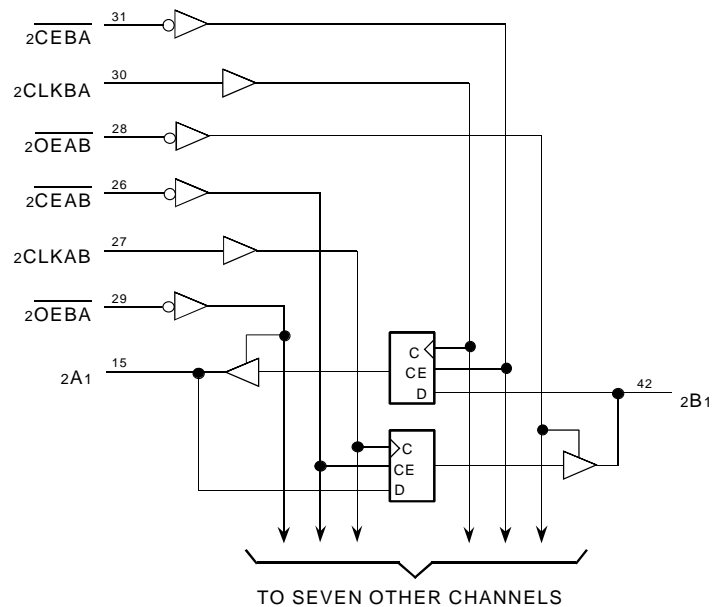
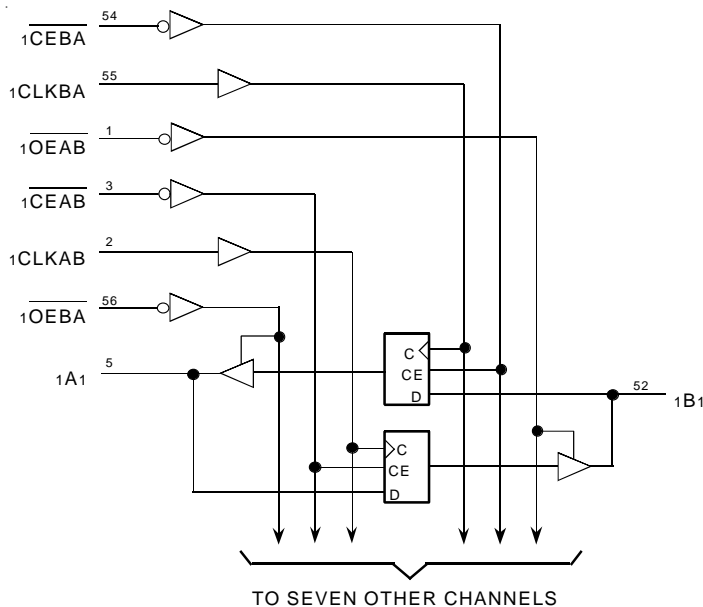

The IDT logo is a registered trademark of Integrated Device Technology, Inc.

**INDUSTRIAL TEMPERATURE RANGE**

**JUNE 2002**

## PIN CONFIGURATION

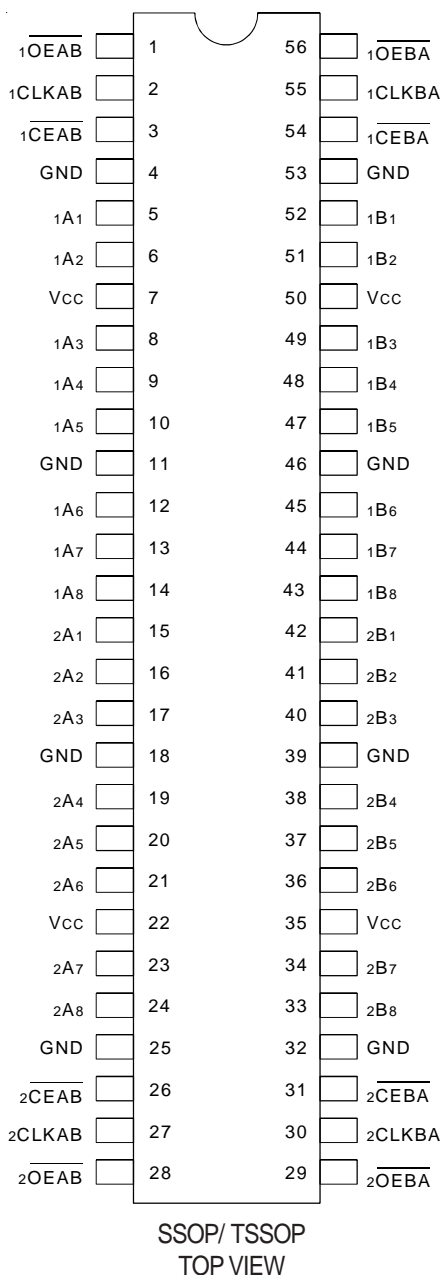

## PIN DESCRIPTION

Pin Names	Description
$\overline{xOEAB}$	A-to-B Output Enable Input (Active LOW)
$\overline{xOEB\overline{A}}$	B-to-A Output Enable Input (Active LOW)
$\overline{xCEAB}$	A-to-B Clock Enable Input (Active LOW)
$\overline{xCEB\overline{A}}$	B-to-A Clock Enable Input (Active LOW)
xCLKAB	A-to-B Clock Input
xCLKBA	B-to-A Clock Input
xAx	A-to-B Data Inputs or B-to-A 3-State Outputs
xBx	B-to-A Data Inputs or A-to-B 3-State Outputs

## ABSOLUTE MAXIMUM RATINGS<sup>(1)</sup>

Symbol	Description	Max	Unit
VTERM <sup>(2)</sup>	Terminal Voltage with Respect to GND	-0.5 to +7	V
VTERM <sup>(3)</sup>	Terminal Voltage with Respect to GND	-0.5 to VCC+0.5	V
TSTG	Storage Temperature	-65 to +150	°C
IOUT	DC Output Current	-60 to +120	mA

### NOTES:

- Stresses greater than those listed under ABSOLUTE MAXIMUM RATINGS may cause permanent damage to the device. This is a stress rating only and functional operation of the device at these or any other conditions above those indicated in the operational sections of this specification is not implied. Exposure to absolute maximum rating conditions for extended periods may affect reliability.
- All device terminals except FCT162XXX Output and I/O terminals.
- Output and I/O terminals for FCT162XXX.

## CAPACITANCE (TA = +25°C, F = 1.0MHz)

Symbol	Parameter <sup>(1)</sup>	Conditions	Typ.	Max.	Unit
CIN	Input Capacitance	VIN = 0V	3.5	6	pF
COU	Output Capacitance	VOUT = 0V	3.5	8	pF

### NOTE:

- This parameter is measured at characterization but not tested.

## FUNCTION TABLE<sup>(1,3)</sup>

Inputs				Outputs
$\overline{xCEAB}$	xCLKAB	$\overline{xOEAB}$	xAx	xBx
H	X	L	X	B <sup>(2)</sup>
X	L	L	X	B <sup>(2)</sup>
L	↑	L	L	L
L	↑	L	H	H
X	X	H	X	Z

### NOTES:

- A-to-B data flow is shown: B-to-A data flow is similar but uses  $\overline{xCEB\overline{A}}$ , xCLKBA, and  $\overline{xOEB\overline{A}}$ .
- Level of B before the indicated steady-state input conditions were established.
- H = HIGH Voltage Level  
L = LOW Voltage Level  
X = Don't Care  
↑ = LOW-to-HIGH Transition  
Z = High-impedance

## DC ELECTRICAL CHARACTERISTICS OVER OPERATING RANGE

Following Conditions Apply Unless Otherwise Specified:

Industrial:  $T_A = -40^{\circ}\text{C}$  to  $+85^{\circ}\text{C}$ ,  $V_{CC} = 5.0\text{V} \pm 10\%$

Symbol	Parameter	Test Conditions <sup>(1)</sup>		Min.	Typ. <sup>(2)</sup>	Max.	Unit
$V_{IH}$	Input HIGH Level	Guaranteed Logic HIGH Level		2	—	—	V
$V_{IL}$	Input LOW Level	Guaranteed Logic LOW Level		—	—	0.8	V
$I_{IH}$	Input HIGH Current (Input pins) <sup>(5)</sup>	$V_{CC} = \text{Max.}$	$V_I = V_{CC}$	—	—	$\pm 1$	$\mu\text{A}$
	Input HIGH Current (I/O pins) <sup>(5)</sup>		$V_I = \text{GND}$	—	—	$\pm 1$	
$I_{IL}$	Input LOW Current (Input pins) <sup>(5)</sup>		$V_I = \text{GND}$	—	—	$\pm 1$	
	Input LOW Current (I/O pins) <sup>(5)</sup>		—	—	—	$\pm 1$	
$I_{OZH}$	High Impedance Output Current (3-State Output pins) <sup>(5)</sup>	$V_{CC} = \text{Max.}$	$V_O = 2.7\text{V}$	—	—	$\pm 1$	$\mu\text{A}$
$I_{OZL}$			$V_O = 0.5\text{V}$	—	—	$\pm 1$	
$V_{IK}$	Clamp Diode Voltage	$V_{CC} = \text{Min.}, I_{IN} = -18\text{mA}$		—	-0.7	-1.2	V
$I_{OS}$	Short Circuit Current	$V_{CC} = \text{Max.}, V_O = \text{GND}^{(3)}$		-80	-140	-250	mA
$V_H$	Input Hysteresis	—		—	100	—	mV
$I_{CCL}$ $I_{CCH}$ $I_{CCZ}$	Quiescent Power Supply Current	$V_{CC} = \text{Max.}$ $V_{IN} = \text{GND}$ or $V_{CC}$		—	5	500	$\mu\text{A}$

## OUTPUT DRIVE CHARACTERISTICS

Symbol	Parameter	Test Conditions <sup>(1)</sup>		Min.	Typ. <sup>(2)</sup>	Max.	Unit
$I_O$	Output Drive Current	$V_{CC} = \text{Max.}, V_O = 2.5\text{V}^{(3)}$		-50	—	-180	mA
$V_{OH}$	Output HIGH Voltage	$V_{CC} = \text{Min.}$ $V_{IN} = V_{IH}$ or $V_{IL}$	$I_{OH} = -3\text{mA}$	2.5	3.5	—	V
			$I_{OH} = -15\text{mA}$	2.4	3.5	—	
			$I_{OH} = -32\text{mA}^{(4)}$	2	3	—	
$V_{OL}$	Output LOW Voltage	$V_{CC} = \text{Min.}$ $V_{IN} = V_{IH}$ or $V_{IL}$	$I_{OL} = 64\text{mA}$	—	0.2	0.55	V
$I_{OFF}$	Input/Output Power Off Leakage <sup>(5)</sup>	$V_{CC} = 0\text{V}, V_{IN}$ or $V_O \leq 4.5\text{V}$		—	—	$\pm 1$	$\mu\text{A}$

### NOTES:

- For conditions shown as Min. or Max., use appropriate value specified under Electrical Characteristics for the applicable device type.
- Typical values are at  $V_{CC} = 5.0\text{V}$ ,  $+25^{\circ}\text{C}$  ambient.
- Not more than one output should be shorted at one time. Duration of the test should not exceed one second.
- Duration of the condition can not exceed one second.
- The test limit for this parameter is  $\pm 5\mu\text{A}$  at  $T_A = -55^{\circ}\text{C}$ .

## POWER SUPPLY CHARACTERISTICS

Symbol	Parameter	Test Conditions <sup>(1)</sup>		Min.	Typ. <sup>(2)</sup>	Max.	Unit
$\Delta I_{CC}$	Quiescent Power Supply Current TTL Inputs HIGH	$V_{CC} = \text{Max.}$ $V_{IN} = 3.4V^{(3)}$		—	0.5	1.5	mA
$I_{CCD}$	Dynamic Power Supply Current <sup>(4)</sup>	$V_{CC} = \text{Max.}$ , Outputs Open $\overline{xOEAB} = \overline{xOEBA} = \text{GND}$ One Input Toggling 50% Duty Cycle	$V_{IN} = V_{CC}$ $V_{IN} = \text{GND}$	—	75	120	$\mu\text{A}/\text{MHz}$
$I_C$	Total Power Supply Current <sup>(6)</sup>	$V_{CC} = \text{Max.}$ , Outputs Open $f_{CP} = 10\text{MHz}$ (xCLKAB) 50% Duty Cycle $\overline{xOEAB} = \overline{xCEAB} = \text{GND}$ $\overline{xOEBA} = V_{CC}$ $f_i = 5\text{MHz}$ 50% Duty Cycle One Bit Toggling	$V_{IN} = V_{CC}$ $V_{IN} = \text{GND}$	—	0.8	1.7	mA
			$V_{IN} = 3.4V$ $V_{IN} = \text{GND}$	—	1.3	3.2	
		$V_{CC} = \text{Max.}$ , Outputs Open $f_{CP} = 10\text{MHz}$ (xCLKAB) 50% Duty Cycle $\overline{xOEAB} = \overline{xCEAB} = \text{GND}$ $\overline{xOEBA} = V_{CC}$ $f_i = 2.5\text{MHz}$ 50% Duty Cycle Sixteen Bits Toggling	$V_{IN} = V_{CC}$ $V_{IN} = \text{GND}$	—	3.8	6.5 <sup>(5)</sup>	
			$V_{IN} = 3.4V$ $V_{IN} = \text{GND}$	—	8.3	20 <sup>(5)</sup>	

### NOTES:

- For conditions shown as Min. or Max., use appropriate value specified under Electrical Characteristics for the applicable device type.
- Typical values are at  $V_{CC} = 5.0V$ ,  $+25^\circ\text{C}$  ambient.
- Per TTL driven input ( $V_{IN} = 3.4V$ ). All other inputs at  $V_{CC}$  or  $\text{GND}$ .
- This parameter is not directly testable, but is derived for use in Total Power Supply Calculations.
- Values for these conditions are examples of the  $I_{CC}$  formula. These limits are guaranteed but not tested.
- $I_C = I_{QUIESCENT} + I_{INPUTS} + I_{DYNAMIC}$   
 $I_C = I_{CC} + \Delta I_{CC} D_H N_T + I_{CCD} (f_{CP} N_{CP} / 2 + f_i N_i)$   
 $I_{CC} = \text{Quiescent Current (} I_{CCL}, I_{CCH} \text{ and } I_{CCZ} \text{)}$   
 $\Delta I_{CC} = \text{Power Supply Current for a TTL High Input (} V_{IN} = 3.4V \text{)}$   
 $D_H = \text{Duty Cycle for TTL Inputs High}$   
 $N_T = \text{Number of TTL Inputs at } D_H$   
 $I_{CCD} = \text{Dynamic Current Caused by an Input Transition Pair (HLH or LHL)}$   
 $f_{CP} = \text{Clock Frequency for Register Devices (Zero for Non-Register Devices)}$   
 $N_{CP} = \text{Number of Clock Inputs at } f_{CP}$   
 $f_i = \text{Input Frequency}$   
 $N_i = \text{Number of Inputs at } f_i$

## SWITCHING CHARACTERISTICS OVER OPERATING RANGE - INDUSTRIAL

Symbol	Parameter	Condition <sup>(1)</sup>	FCT16952AT		FCT16952CT		FCT16952ET		Unit
			Min. <sup>(2)</sup>	Max.	Min. <sup>(2)</sup>	Max.	Min. <sup>(2)</sup>	Max.	
t <sub>PLH</sub> t <sub>PHL</sub>	Propagation Delay xCLKAB, xCLKBA to xBx, xAx	CL = 50pF RL = 500Ω	2	10	2	6.3	1.5	3.7	ns
t <sub>PZH</sub> t <sub>PZL</sub>	Output Enable Time xOEBA, xOEAB to xAx, xBx		1.5	10.5	1.5	7	1.5	4.4	ns
t <sub>PHZ</sub> t <sub>PLZ</sub>	Output Disable Time xOEBA, xOEAB to xAx, xBx		1.5	10	1.5	6.5	1.5	3.6	ns
t <sub>SU</sub>	Set-up Time, HIGH or LOW xAx, xBx to xCLKAB, xCLKBA		2.5	—	2.5	—	1.5	—	ns
t <sub>H</sub>	Hold Time, HIGH or LOW xAx, xBx to xCLKAB, xCLKBA		2	—	1.5	—	0	—	ns
t <sub>SU</sub>	Set-up Time, HIGH or LOW xCEBA, xCEAB, to xCLKAB, xCLKBA		3	—	3	—	2	—	ns
t <sub>H</sub>	Hold Time, HIGH or LOW xCEBA, xCEAB, to xCLKAB, xCLKBA		2	—	2	—	0	—	ns
t <sub>w</sub>	Pulse Width HIGH or LOW, xCLKAB or xCLKBA <sup>(3)</sup>		3	—	3	—	3	—	ns
t <sub>sk(o)</sub>	Output Skew <sup>(4)</sup>		—	0.5	—	0.5	—	0.5	ns

NOTES:

1. See test circuit and waveforms.
2. Minimum limits are guaranteed but not tested on Propagation Delays.
3. This limit is guaranteed but not tested.
4. Skew between any two outputs, of the same package, switching in the same direction. This parameter is guaranteed by design.

## TEST CIRCUITS AND WAVEFORMS

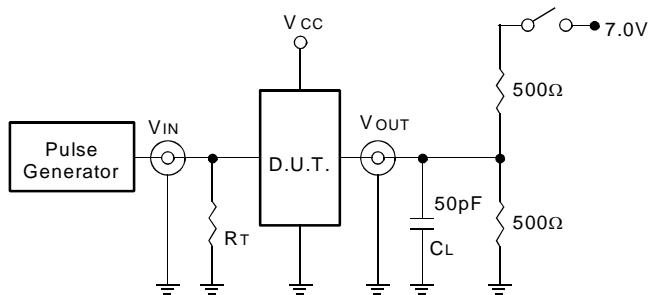

Test Circuits for All Outputs

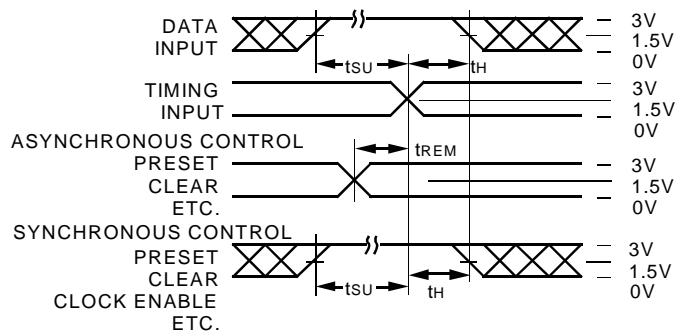

Set-up, Hold, and Release Times

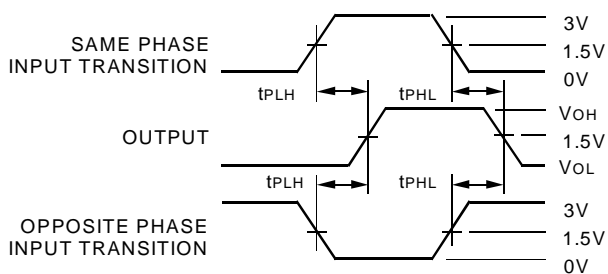

Propagation Delay

## SWITCH POSITION

Test	Switch
Open Drain Disable Low Enable Low	Closed
All Other Tests	Open

### DEFINITIONS:

CL = Load capacitance: includes jig and probe capacitance.

RT = Termination resistance: should be equal to Zout of the Pulse Generator.

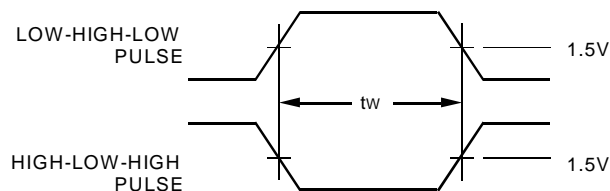

Pulse Width

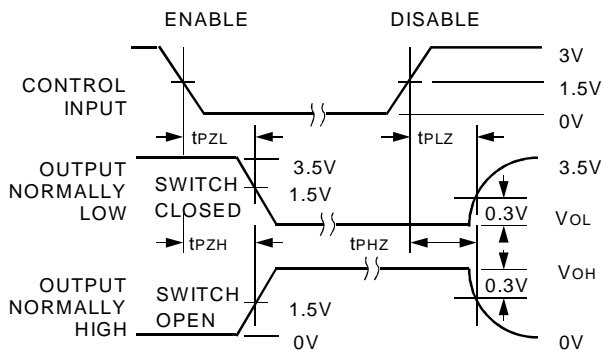

Enable and Disable Times

### NOTES:

1. Diagram shown for input Control Enable-LOW and input Control Disable-HIGH.
2. Pulse Generator for All Pulses: Rate  $\leq 1.0\text{MHz}$ ;  $t_f \leq 2.5\text{ns}$ ;  $t_r \leq 2.5\text{ns}$ .

## ORDERING INFORMATION

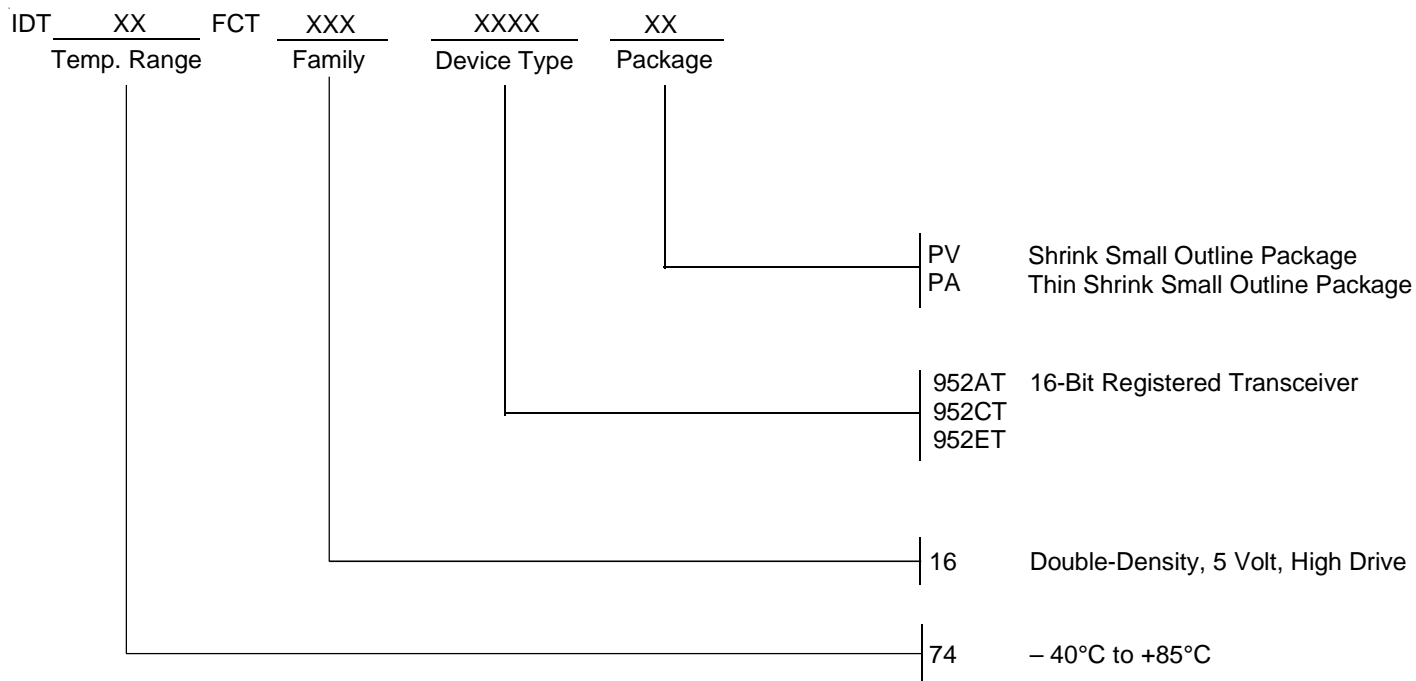

## DATA SHEET DOCUMENT HISTORY

6/24/2002 Updated as per PDNs Logic-00-07 and Logic-01-04



**CORPORATE HEADQUARTERS**  
 2975 Stender Way  
 Santa Clara, CA 95054

*for SALES:*  
 800-345-7015 or 408-727-6116  
 fax: 408-492-8674  
 www.idt.com

*for Tech Support:*  
 logichelp@idt.com  
 (408) 654-6459