

## Si4012 CRYSTAL-LESS RF TRANSMITTER

### Features

- Frequency range
  - 27–960 MHz
- Output Power Range
  - –13 to +10 dBm
- Low Power Consumption
  - OOK
    - 14.2 mA @ +10 dBm
  - FSK
    - 19.8 mA @ +10 dBm
- Data Rate = 0 to 100 kbaud FSK
- FSK and OOK modulation
- Power Supply = 1.8 to 3.6 V
- Crystal-less operation
  - ±150 ppm: 0 to 20° C
  - ±250 ppm: –40 to 85° C
  - Optional crystal input for higher tolerances
- Low power shutdown mode
- Integrated voltage regulator
- 256 byte FIFO
- Low battery detector
- SMBus Interface
- –40 to +85 °C temperature range
- 10-Pin MSOP Package, Pb-free
- RoHs compliant
- Low BOM

### Applications

- Wireless MBus T1-mode
- Remote control
- Home security & alarm
- Personal data logging
- Toy control
- Wireless PC peripherals
- Remote meter reading
- Remote keyless entry
- Home automation
- Industrial control
- Sensor networks
- Health monitors

### Description

Silicon Laboratories' Si4012 is a fully integrated crystal-less CMOS high-data rate RF transmitter designed for the sub-GHz ISM band. This chip is optimized for battery powered applications requiring low standby currents and high output transmit power.

The device offers advanced radio features including continuous frequency coverage from 27–960 MHz, adjustable output power of up to +10 dBm, and data rates up to 100 kbaud in FSK mode. The Si4012's high level of integration offers reduced BOM cost while simplifying the overall system design.

### Functional Block Diagram

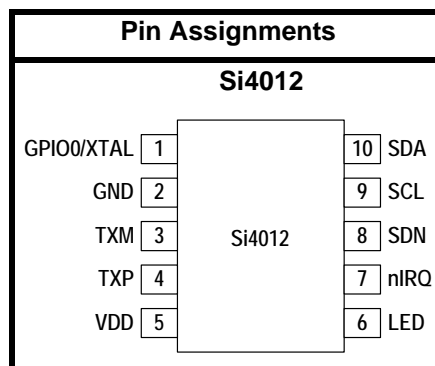
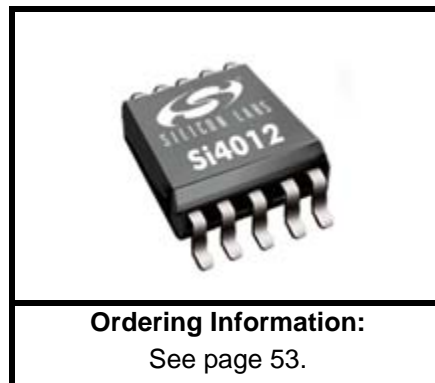
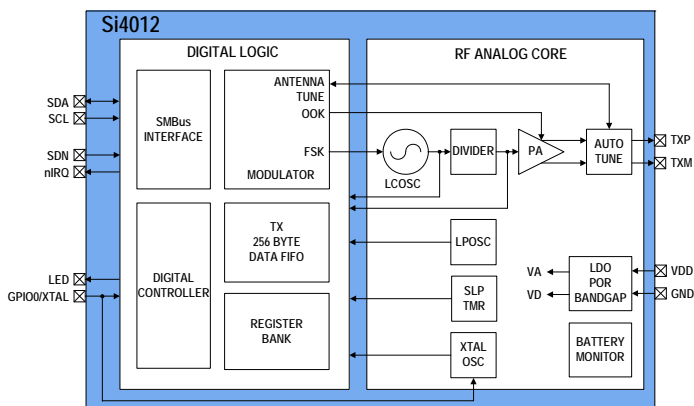

Patents pending



---

**TABLE OF CONTENTS**

---

<b><u>Section</u></b>	<b><u>Page</u></b>
<b>1. Electrical Specifications</b> .....	<b>4</b>
1.1. Definition of Test Conditions .....	9
<b>2. Functional Description</b> .....	<b>10</b>
<b>3. Pin Descriptions: Si4012</b> .....	<b>11</b>
<b>4. Ordering Information</b> .....	<b>12</b>
<b>5. Package Outline: Si4012</b> .....	<b>13</b>
<b>6. PCB Land Pattern: Si4012</b> .....	<b>14</b>
<b>Contact Information</b> .....	<b>16</b>

## 1. Electrical Specifications

**Table 1. DC Characteristics<sup>1</sup>**

Parameter	Symbol	Conditions	Min	Typ	Max	Units
Supply Voltage Range	$V_{DD}$		1.8	—	3.6	V
Power Saving Modes	$I_{Shutdown}$	Lowest current mode	—	100	—	nA
	$I_{Idle}$	Register values retained, lowest current consumption idle mode	—	700	—	nA
TUNE Mode Current	$I_{Tune}$	Register values retained, LCOSC on fastest response to TX mode	—	5	—	mA
TX Mode Current @ 10 dBm	$I_{TX\_OOK}$	OOK, Manchester encoded	—	14.2	—	mA
	$I_{TX\_FSK}$	FSK	—	19.8	—	mA

**Notes:**

- All specification guaranteed by production test unless otherwise noted. Production test conditions and max limits are listed in the "Production Test Conditions" section on page 9.
- Guaranteed by qualification. Qualification test conditions are listed in the "Production Test Conditions" section on page 9.

**Table 2. Absolute Maximum Ratings<sup>1,2</sup>**

Parameter	Symbol	Value	Unit
Supply Voltage	$V_{DD}$	-0.5 to 3.9	V
Input Current <sup>3</sup>	$I_{IN}$	10	mA
Input Voltage <sup>4</sup>	$V_{IN}$	-0.3 to ( $V_{DD} + 0.3$ )	V
Junction Temperature	$T_{OP}$	-40 to 90	°C
Storage Temperature	$T_{STG}$	-55 to 125	°C

**Notes:**

- Permanent device damage may occur if the absolute maximum ratings are exceeded. Functional operation should be restricted to the conditions as specified in the operational sections of this data sheet. Exposure beyond recommended operating conditions for extended periods may affect device reliability.
- Handling and assembly of these devices should only be done at ESD-protected workstations.
- All input pins besides  $V_{DD}$ .
- For GPIO pins configured as inputs.

**Table 3. Si4012 RF Transmitter Characteristics**

(TA = 25° C, VDD = 3.3 V, RL = 550 Ω, unless otherwise noted)

Parameter	Symbol	Test Condition	Min	Typ	Max	Unit
Frequency Range <sup>1</sup>	F <sub>RF</sub>		27	—	960	MHz
Frequency Noise (rms) <sup>2</sup>		Allen deviation, measured across 1 ms interval	—	0.3	—	ppm
Phase Noise @ 915 MHz		10 kHz offset	—	-70	—	dBc/Hz
		100 kHz offset	—	-100	—	dBc/Hz
		1 MHz offset	—	-105	—	dBc/Hz
Frequency Tuning Time			—	5	—	ms
Selected Frequencies in Range of 27–960 MHz		Discrete frequencies	—	315	—	MHz
			—	390	—	MHz
			—	433.92	—	MHz
			—	868	—	MHz
			—	915	—	MHz
Carrier Frequency Accuracy		0°C ≤ T <sub>A</sub> ≤ 70° C	-150		+150	ppm
		-40°C ≤ T <sub>A</sub> ≤ 85° C	-250		+250	ppm
		F <sub>RF</sub> = 100 MHz 0°C ≤ T <sub>A</sub> ≤ 70° C	-15	—	15	kHz
		F <sub>RF</sub> = 100 MHz -40°C ≤ T <sub>A</sub> ≤ 85° C	-25	—	25	kHz
		F <sub>RF</sub> = 315 MHz 0°C ≤ T <sub>A</sub> ≤ 70° C	-47.3	—	47.3	kHz
		F <sub>RF</sub> = 315 MHz -40°C ≤ T <sub>A</sub> ≤ 85° C	-78.8	—	78.8	kHz
		F <sub>RF</sub> = 433.92 MHz 0°C ≤ T <sub>A</sub> ≤ 70° C	-65.1	—	65.1	kHz
		F <sub>RF</sub> = 433.92 MHz -40°C ≤ T <sub>A</sub> ≤ 85° C	-108	—	108	kHz
		F <sub>RF</sub> = 868 MHz 0°C ≤ T <sub>A</sub> ≤ 70° C	-130	—	130	kHz
		F <sub>RF</sub> = 868 MHz -40°C ≤ T <sub>A</sub> ≤ 85° C	-217	—	217	kHz
		F <sub>RF</sub> = 915 MHz 0°C ≤ T <sub>A</sub> ≤ 70° C	-137	—	137	kHz
		F <sub>RF</sub> = 915 MHz -40°C ≤ T <sub>A</sub> ≤ 85° C	-229	—	229	kHz
Frequency Error Contribution with External Crystal			-10	—	+10	ppm

**Notes:**

1. The frequency range is continuous over the specified range.
2. The frequency step size is limited by the frequency noise.
3. Optimum differential load is equal to  $4 V / (11.5 \text{ mA} / 2 * 4 / \pi) = 550 \Omega$ . Therefore the antenna load resistance in parallel with the Si4012 differential output resistance should equal 600 Ω.

**Table 3. Si4012 RF Transmitter Characteristics (Continued)**

(TA = 25° C, VDD = 3.3 V, RL = 550 Ω, unless otherwise noted)

Parameter	Symbol	Test Condition	Min	Typ	Max	Unit
Transmit Power <sup>3</sup>		Maximum programmed Tx power, with optimum differential load, V <sub>DD</sub> > 2.2 V	—	10	—	dBm
		Minimum programmed TX power, with optimum differential load, V <sub>DD</sub> > 2.2 V	—	-13	—	dBm
		Power variation vs temp and supply, with optimum differential load, V <sub>DD</sub> > 2.2 V	-1.0	—	0.5	dB
		Power variation vs temp and supply, with optimum differential load, V <sub>DD</sub> > 1.8 V	-2.5	—	0.5	dB
		Transmit power step size from -13 to 6.5 dBm	—	0.25	—	dB
PA Edge Ramp Rate Programmable Range		OOK mode	0.34	—	10.7	us
Data Rate		OOK	0.1	—	50	kbaud
		FSK	0.1	—	100	kbaud
<b>Notes:</b>						
1. The frequency range is continuous over the specified range.						
2. The frequency step size is limited by the frequency noise.						
3. Optimum differential load is equal to $4 V / (11.5 \text{mA} / 2 * 4 / \text{PI}) = 550 \Omega$ . Therefore the antenna load resistance in parallel with the Si4012 differential output resistance should equal 600 Ω.						

**Table 3. Si4012 RF Transmitter Characteristics (Continued)**

(TA = 25° C, VDD = 3.3 V, RL = 550 Ω, unless otherwise noted)

Parameter	Symbol	Test Condition	Min	Typ	Max	Unit
FSK Deviation		Max frequency deviation	—	300	—	ppm
		Deviation resolution	—	2	—	ppm
		Deviation accuracy		TBD		ppm
		Max frequency deviation, 100 MHz	—	30	—	kHz
		Deviation resolution, 100 MHz	—	200	—	Hz
		Max frequency deviation, 315 MHz	—	95	—	kHz
		Deviation resolution, 315 MHz	—	630	—	Hz
		Max frequency deviation, 433.92 MHz	—	130	—	kHz
		Deviation resolution, 433.92 MHz	—	868	—	Hz
		Max frequency deviation, 868 MHz	—	260	—	kHz
		Deviation resolution, 868 MHz	—	1740	—	Hz
		Max frequency deviation, 915 MHz	—	275	—	kHz
		Deviation resolution, 915 MHz	—	1830	—	Hz
OOK Modulation depth			60	—	—	dB
Antenna Tuning Capacitive Range (Differential)		315 MHz	2.4	—	12.5	pF
<b>Notes:</b>						
1. The frequency range is continuous over the specified range.						
2. The frequency step size is limited by the frequency noise.						
3. Optimum differential load is equal to $4 V / (11.5 \text{ mA} / 2 * 4 / \text{PI}) = 550 \Omega$ . Therefore the antenna load resistance in parallel with the Si4012 differential output resistance should equal 600 Ω.						

**Table 4. Low Battery Detector Characteristics**

(TA = 25° C, VDD = 3.3 V, RL = 550 Ω, unless otherwise noted)

Parameter	Symbol	Test Condition	Min	Typ	Max	Unit
Battery Voltage Measurement Accuracy			—	2	—	%

**Table 5. Optional Crystal Oscillator Characteristics**

(TA = 25° C, VDD = 3.3 V, RL = 600 Ω, unless otherwise noted)

Parameter	Symbol	Test Condition	Min	Typ	Max	Unit
Crystal Frequency Range		GPIO configured as crystal oscillator	10	—	13	MHz
Input Capacitance (GPIO0)		GPIO configured as crystal oscillator	—	5	—	pF
Crystal ESR		GPIO configured as crystal oscillator	—	—	50	Ω
Start-up Time		Crystal oscillator only, 60 mH motional arm inductance	—	9	—	ms

**Table 6. EEPROM Characteristics**

Parameter	Conditions	Min	Typ	Max	Units
Program Time	Independent of number of bits changing values	—	8	40	ms
Maximum Count per Counter	Using API		1000000		cycles
Write Endurance (per bit)*		50000	—	—	cycles

**Note:** \*API uses coding technique to achieve write endurance of 1M cycles per bit.

**Table 7. Low Power Oscillator Characteristics**

V<sub>DD</sub> = 1.8 to 3.6 V; T<sub>A</sub> = -40 to +85 °C unless otherwise specified. Use factory-calibrated settings.

Parameter	Conditions	Min	Typ	Max	Units
Programmable Frequency Range	Programmable divider in powers of 2 up to 128	.1875	—	24	MHz
Frequency Accuracy		-1	—	+1	%



## 1.1. Definition of Test Conditions

### Production Test Conditions:

- $T_A = +25\text{ °C}$
- $V_{DD} = +3.3\text{ VDC}$
- TX output power measured at 100 MHz
- All RF output levels referred to the pins of the Si4012 (not the RF module)

### Qualification Test Conditions:

- $T_A = -40\text{ to }+85\text{ °C}$
- $V_{DD} = +1.8\text{ to }+3.6\text{ VDC}$
- All RF output levels referred to the pins of the Si4012 (not the RF module)

## 2. Functional Description

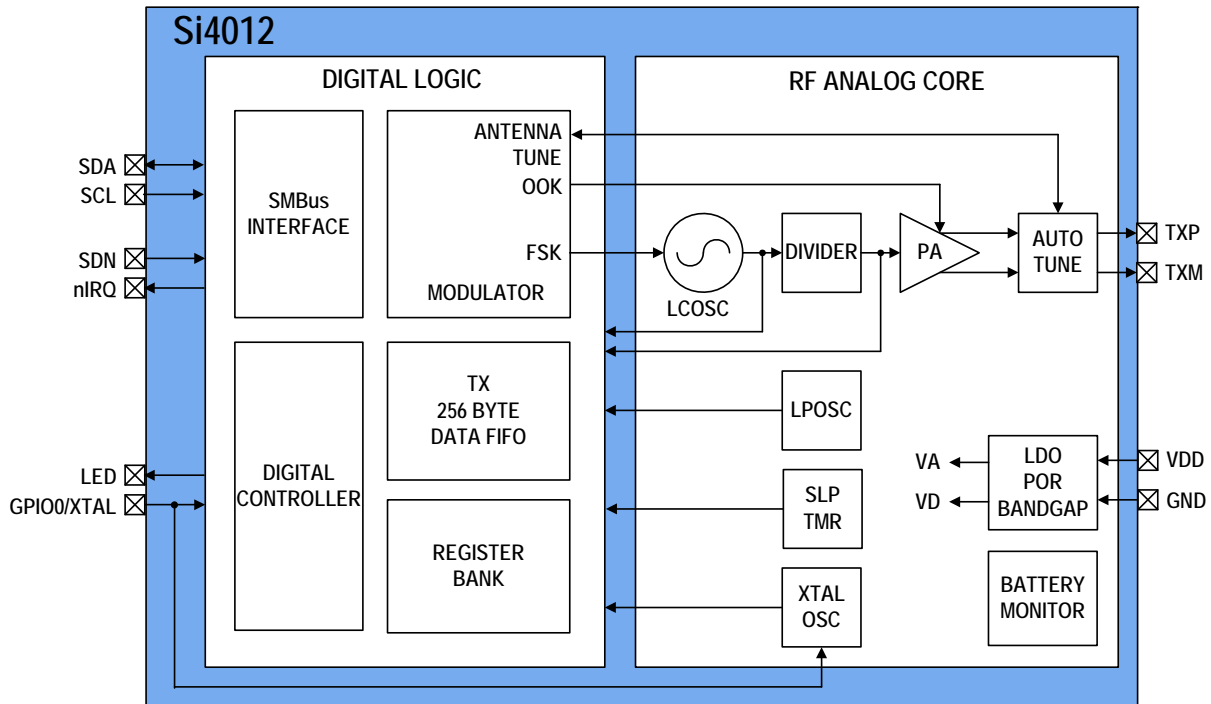

**Figure 1. Si4012 Functional Block Diagram**

The Si4012 is a crystal wireless transmitter with continuous frequency tuning over the frequency range of 27–960 MHz. The wide operating voltage range of 1.8–3.6 V and low current consumption makes the Si4012 an ideal solution for battery powered applications.

The RF carrier is generated by Silicon Labs patented pending crystal-less oscillator technology. The device achieves a frequency accuracy of  $\pm 150$  ppm over the commercial temperature range of 0 to 70 °C and  $\pm 250$  ppm over the industrial temperature range of –40 to +85 °C.

The Si4012's PA output power can be configured between –13 to +10 dBm with 0.25 dB of resolution. The PA incorporates automatic ramp-up and ramp-down control to reduce unwanted spectral spreading.

The Si4012 is designed to work with a microcontroller to allow custom configuration of the transmitter for optimum performance. Voltage regulators are integrated on-chip which allows for a wide operating supply voltage range of 1.8 to 3.6 V. A standard 2-pin SMB ( $I^2C$ ) bus is used to communicate with an external microcontroller.

### 3. Pin Descriptions: Si4012

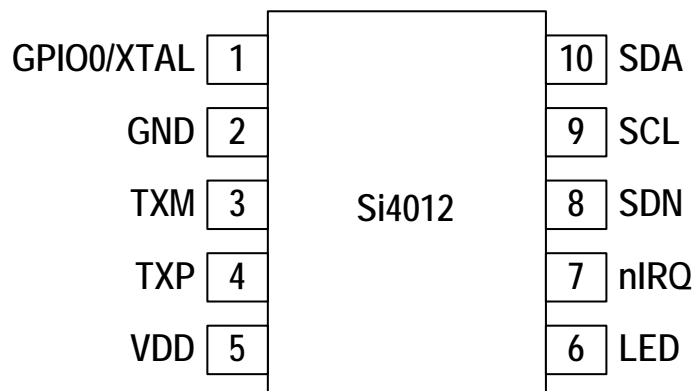

Pin Number	Name	Description
1	GPIO0/XTAL	General purpose input or crystal input
2	GND	Ground
3,4	TXM, TXP	RF transmitter differential outputs
5	VDD	Supply input
9	LED	LED driver output pin
7	nIRQ	Interrupt status output, active low
8	SDN	Shutdown input pin, active high
9	SCL	SMB (I <sup>2</sup> C) Clock input
10	SDA	SMB (I <sup>2</sup> C) Data input/output pin

# Si4012

---

## 4. Ordering Information

Part Number*	Description	Package Type	Operating Temperature
Si4012-A0-GT	Crystal-less RF Transmitter	MSOP-10	-40 to 85 °C

\*Note: Add an "(R)" at the end of the device part number to denote tape and reel option.

## 5. Package Outline: Si4012

Figure 21 illustrates the package details for the Si4012. Table 16 lists the values for the dimensions shown in the illustration.

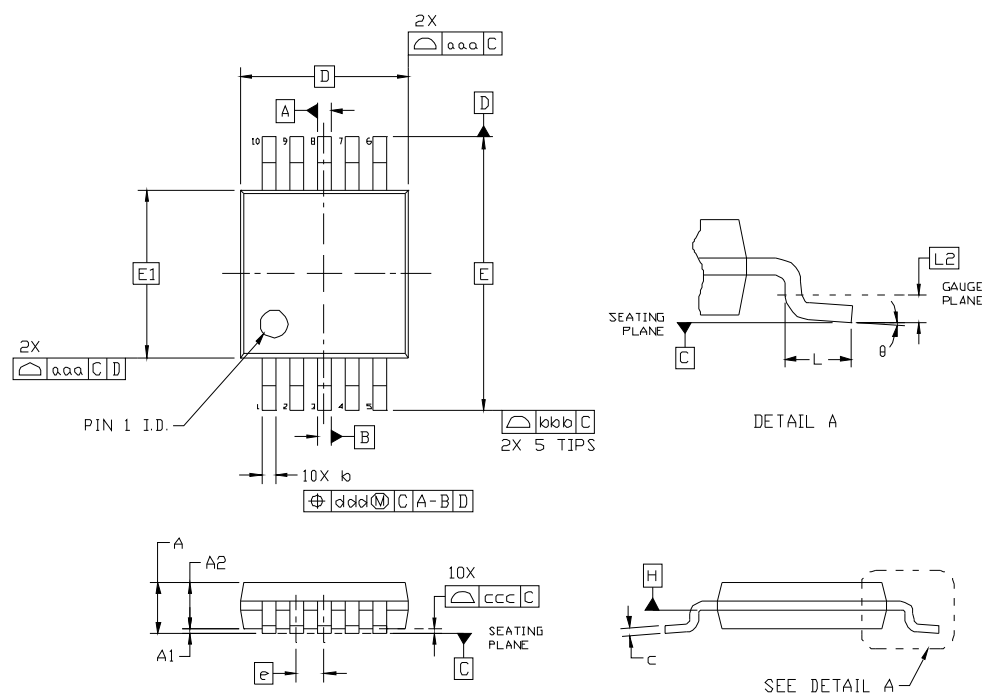

Figure 2. 20-Pin Quad Flat No-Lead (QFN)

Table 8. Package Dimensions

Symbol	Millimeters		
	Min	Nom	Max
A	—	—	1.10
A1	0.00	—	0.15
A2	0.75	0.85	0.95
b	0.17	—	0.33
c	0.08	—	0.23
D	3.00 BSC		
E	4.90 BSC		
E1	3.00 BSC		

Symbol	Millimeters		
	Min	Nom	Max
e	0.50 BSC		
L	0.40	0.60	0.80
L2	0.25 BSC		
q	0°	—	8°
aaa	—	—	0.20
bbb	—	—	0.25
ccc	—	—	0.10
ddd	—	—	0.08

**Notes:**

1. All dimensions are shown in millimeters (mm).
2. Dimensioning and tolerancing per ASME Y14.5M-1994.
3. This drawing conforms to JEDEC Outline MO-187, Variation "BA."
4. Recommended card reflow profile is per the JEDEC/IPC J-STD-020 specification for Small Body Components.

## 6. PCB Land Pattern: Si4012

Figure 2 illustrates the PCB land pattern details for the Si4012. Table 17 lists the values for the dimensions shown in the illustration.

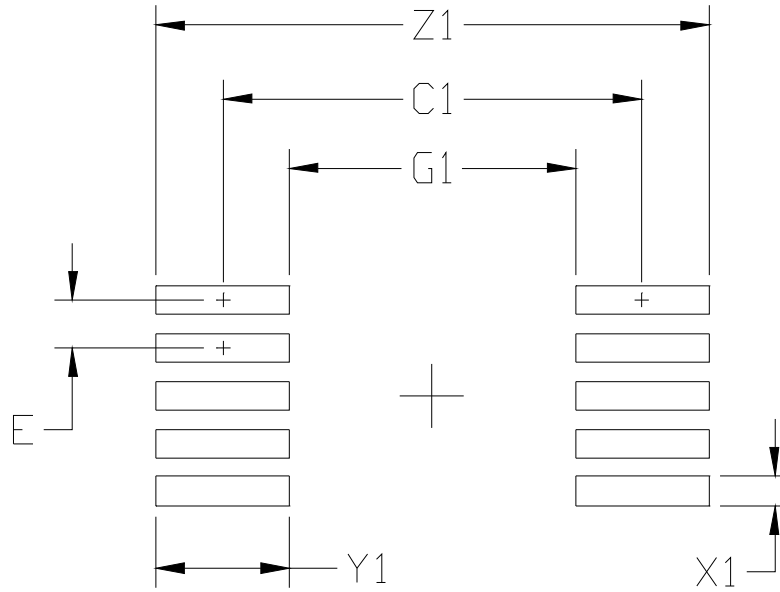

Figure 3. PCB Land Pattern

Table 9. 10-Pin MSOP Package Dimensions

Dimension	MIN	MAX
C1	4.40 REF	
E	0.50 BSC	
G1	3.00	—
X1	—	0.30
Y1	1.40 REF	
Z1	—	5.80

**Notes:****General**

1. All dimensions shown are in millimeters (mm) unless otherwise noted.
2. Dimensioning and Tolerancing per ASME Y14.5M-1994.
3. This Land Pattern Design is based on the IPC-7351 guidelines.
4. All dimensions shown are at Maximum Material Condition (MMC). Least Material Condition (LMC) is calculated based on a Fabrication Allowance of 0.05 mm.

**Solder Mask Design**

1. All metal pads are to be non-solder mask defined (NSMD). Clearance between the solder mask and the metal pad is to be 60  $\mu\text{m}$  minimum, all the way around the pad.

**Stencil Design**

1. A stainless steel, laser-cut and electro-polished stencil with trapezoidal walls should be used to assure good solder paste release.
2. The stencil thickness should be 0.125 mm (5 mils).
3. The ratio of stencil aperture to land pad size should be 1:1.

**Card Assembly**

1. A No-Clean, Type-3 solder paste is recommended.
2. The recommended card reflow profile is per the JEDEC/IPC J-STD-020 specification for Small Body Components.

## CONTACT INFORMATION

### Silicon Laboratories Inc.

400 West Cesar Chavez  
Austin, TX 78701  
Tel: 1+(512) 416-8500  
Fax: 1+(512) 416-9669  
Toll Free: 1+(877) 444-3032

Please visit the Silicon Labs Technical Support web page:  
<https://www.silabs.com/support/pages/contacttechnicalsupport.aspx>  
and register to submit a technical support request.

The information in this document is believed to be accurate in all respects at the time of publication but is subject to change without notice. Silicon Laboratories assumes no responsibility for errors and omissions, and disclaims responsibility for any consequences resulting from the use of information included herein. Additionally, Silicon Laboratories assumes no responsibility for the functioning of undescribed features or parameters. Silicon Laboratories reserves the right to make changes without further notice. Silicon Laboratories makes no warranty, representation or guarantee regarding the suitability of its products for any particular purpose, nor does Silicon Laboratories assume any liability arising out of the application or use of any product or circuit, and specifically disclaims any and all liability, including without limitation consequential or incidental damages. Silicon Laboratories products are not designed, intended, or authorized for use in applications intended to support or sustain life, or for any other application in which the failure of the Silicon Laboratories product could create a situation where personal injury or death may occur. Should Buyer purchase or use Silicon Laboratories products for any such unintended or unauthorized application, Buyer shall indemnify and hold Silicon Laboratories harmless against all claims and damages.

Silicon Laboratories and Silicon Labs are trademarks of Silicon Laboratories Inc.  
Other products or brandnames mentioned herein are trademarks or registered trademarks of their respective holders.