

FEATURES

- Low Side Chopper Switch
- n - Channel IGBT
- Isolated Base

APPLICATIONS

- Choppers
- Motor Control
- Power Supplies

The Powerline range of modules includes half bridge, chopper, dual and single switch configurations covering voltages from 600V to 3300V and currents up to 2400A.

The GP250MLS06S is a 600V n channel enhancement mode insulated gate bipolar transistor (IGBT) chopper module configured with the lower arm of the bridge controlled. The module is suitable for a variety of medium voltage applications in motor drives and power conversion.

The IGBT has a wide reverse bias safe operating area (RBSOA) for ultimate reliability in demanding applications.

These modules incorporate electrically isolated base plates and low inductance construction enabling circuit designers to optimise circuit layouts and utilise earthed heat sinks for safety.

ORDERING INFORMATION

Order as:

GP250MLS06S

Note: When ordering, use complete part number.

KEY PARAMETERS

V_{CES} **600V**

$V_{CE(sat)}$ * (typ) **2.2V**

I_{C25} (max) **350A**

I_{C75} (max) **250A**

$I_{C(PK)}$ (max) **700A**

*(measured at the power busbars and not the auxiliary terminals)

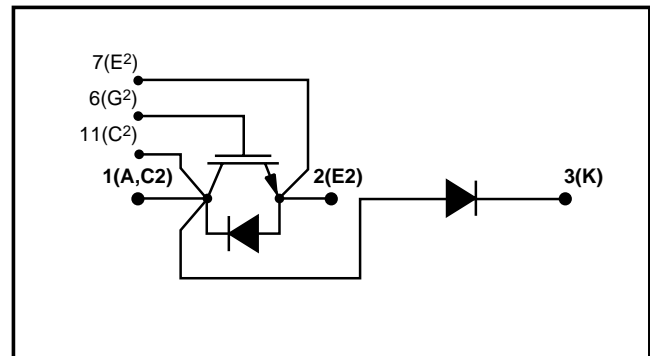

Fig. 1 Chopper circuit diagram - lower arm controlled

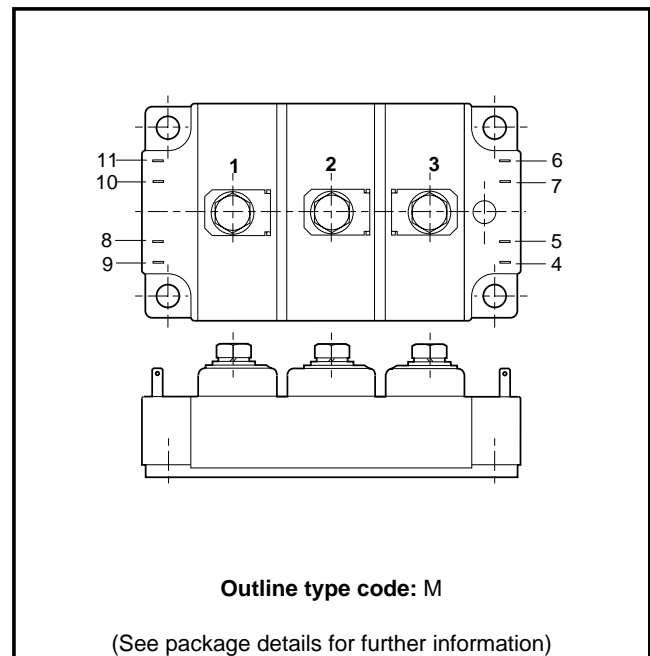

Fig. 2 Electrical connections - (not to scale)

Caution: This device is sensitive to electrostatic discharge. Users should follow ESD handling procedures.

ABSOLUTE MAXIMUM RATINGS - PER ARM

Stresses above those listed under 'Absolute Maximum Ratings' may cause permanent damage to the device. In extreme conditions, as with all semiconductors, this may include potentially hazardous rupture of the package. Appropriate safety precautions should always be followed. Exposure to Absolute Maximum Ratings may affect device reliability.

$T_{\text{case}} = 25^{\circ}\text{C}$ unless stated otherwise

Symbol	Parameter	Test Conditions	Max.	Units
V_{CES}	Collector-emitter voltage	$V_{\text{GE}} = 0\text{V}$	600	V
V_{GES}	Gate-emitter voltage	-	± 20	V
I_{C}	Collector current	DC, $T_{\text{case}} = 25^{\circ}\text{C}$	350	A
		DC, $T_{\text{case}} = 75^{\circ}\text{C}$	250	A
$I_{\text{C(PK)}}$		1ms, $T_{\text{case}} = 25^{\circ}\text{C}$	700	A
		1ms, $T_{\text{case}} = 75^{\circ}\text{C}$	500	A
P_{max}	Maximum power dissipation	(Transistor)	1250	W
V_{isol}	Isolation voltage	Commoned terminals to base plate. AC RMS, 1 min, 50Hz	2500	V

THERMAL AND MECHANICAL RATINGS

Internal insulation: Al_2O_3
 Baseplate material: Cu
 Creepage distance: 22mm
 Clearance: 12mm
 CTI (Critical Tracking Index): 175

Symbol	Parameter	Test Conditions	Min.	Typ.	Max.	Units
$R_{th(j-c)}$	Thermal resistance - transistor (per arm)	Continuous dissipation - junction to case	-	-	87	$^{\circ}\text{C}/\text{kW}$
$R_{th(j-c)}$	Thermal resistance - diode (per arm) (Antiparallel and freewheel diode)	Continuous dissipation - junction to case	-	-	194	$^{\circ}\text{C}/\text{kW}$
$R_{th(c-h)}$	Thermal resistance - case to heatsink (per module)	Mounting torque 5Nm (with mounting grease)	-	-	15	$^{\circ}\text{C}/\text{kW}$
T_j	Junction temperature	Transistor	-	-	150	$^{\circ}\text{C}$
		Diode	-	-	125	$^{\circ}\text{C}$
T_{stg}	Storage temperature range	-	-40	-	125	$^{\circ}\text{C}$
-	Screw torque	Mounting - M6	-	-	5	Nm
		Electrical connections - M4	-	-	2	Nm

Caution: This device is sensitive to electrostatic discharge. Users should follow ESD handling procedures.

3/10

www.dynexsemi.com

ELECTRICAL CHARACTERISTICS

$T_j = 25^\circ\text{C}$ unless stated otherwise.

Symbol	Parameter	Conditions	Min.	Typ.	Max.	Units
I_{CES}	Collector cut-off current (IGBT and diode arms)	$V_{GE} = 0V, V_{CE} = V_{CES}$	-	-	15	mA
		$V_{GE} = 0V, V_{CE} = V_{CES}, T_j = 125^\circ\text{C}$	-	-	50	mA
I_{GES}	Gate leakage current	$V_{GE} = \pm 20V, V_{CE} = 0V$	-	-	1	μA
$V_{GE(TH)}$	Gate threshold voltage	$I_C = 10\text{mA}, V_{GE} = V_{CE}$	4	-	7.5	V
$V_{CE(SAT)}^\dagger$	Collector-emitter saturation voltage	$V_{GE} = 15V, I_C = 250A$	-	2.2	2.7	V
		$V_{GE} = 15V, I_C = 250A, T_j = 125^\circ\text{C}$	-	2.3	2.8	V
I_F	Diode forward current	DC	-	-	250	A
I_{FM}	Diode maximum forward current	$t_p = 1\text{ms}$	-	-	500	A
V_F^\dagger	Diode forward voltage (IGBT and diode arms)	$I_F = 250A,$	-	1.1	1.9	V
		$I_F = 250A, T_j = 125^\circ\text{C}$	-	1.05	1.8	V
C_{ies}	Input capacitance	$V_{CE} = 25V, V_{GE} = 0V, f = 1\text{MHz}$	-	27000	-	pF

Note:

† Measured at the power busbars and not the auxiliary terminals

* L is the circuit inductance + L_M

INDUCTIVE SWITCHING CHARACTERISTICS
 $T_J = 25^\circ\text{C}$ unless stated otherwise

Symbol	Parameter	Conditions	Min.	Typ.	Max.	Units
$t_{d(\text{off})}$	Turn-off delay time	$I_C = 250\text{A}$ $V_{GE} = \pm 15\text{V}$ $V_{CE} = 50\% V_{CES}$ $R_{G(\text{ON})} = R_{G(\text{OFF})} = 5\Omega$ $L \sim 100\text{nH}$	-	810	-	ns
t_f	Fall time		-	310	-	ns
E_{OFF}	Turn-off energy loss		-	20	-	mJ
$t_{d(\text{on})}$	Turn-on delay time		-	330	-	ns
t_r	Rise time		-	130	-	ns
E_{ON}	Turn-on energy loss		-	12	-	mJ
t_{rr}	Diode reverse recovery time	$I_F = 250\text{A}$	-	165	-	ns
Q_{rr}	Diode reverse recovery charge	$V_R = 50\%V_{CES}, di_F/dt = 1500\text{A}/\mu\text{s}$	-	15	-	μC

 $T_J = 125^\circ\text{C}$ unless stated otherwise.

$t_{d(\text{off})}$	Turn-off delay time	$I_C = 250\text{A}$ $V_{GE} = \pm 15\text{V}$ $V_{CE} = 50\% V_{CES}$ $R_{G(\text{ON})} = R_{G(\text{OFF})} = 5\Omega$ $L \sim 200\text{nH}$	-	1050	-	ns
t_f	Fall time		-	450	-	ns
E_{OFF}	Turn-off energy loss		-	30	-	mJ
$t_{d(\text{on})}$	Turn-on delay time		-	380	-	ns
t_r	Rise time		-	160	-	ns
E_{ON}	Turn-on energy loss		-	18	-	mJ
t_{rr}	Diode reverse recovery time	$I_F = 250\text{A}$	-	230	-	ns
Q_{rr}	Diode reverse recovery charge	$V_R = 50\%V_{CES}, di_F/dt = 1500\text{A}/\mu\text{s}$	-	23	-	μC

TYPICAL CHARACTERISTICS

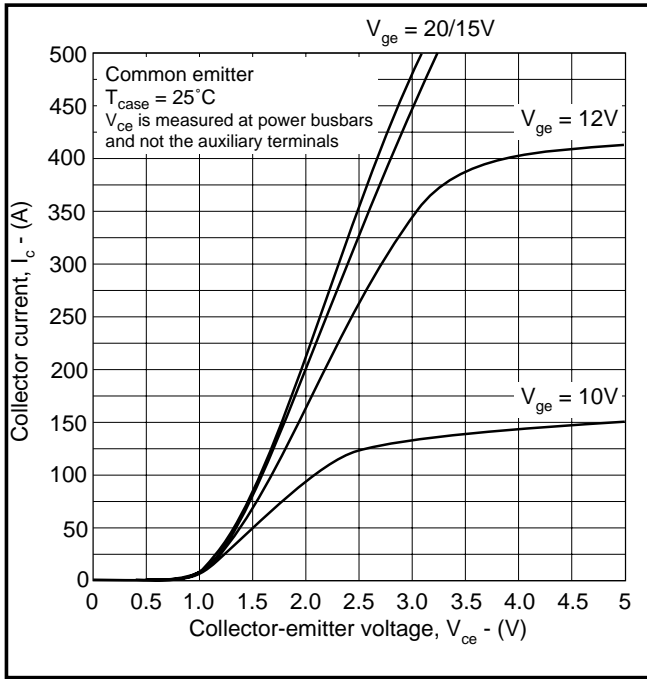

Fig.3 Typical output characteristics

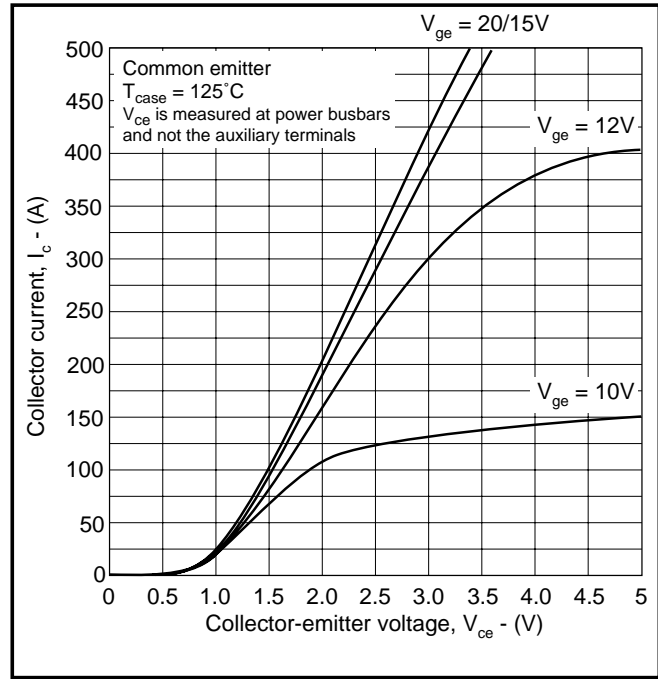

Fig.4 Typical output characteristics

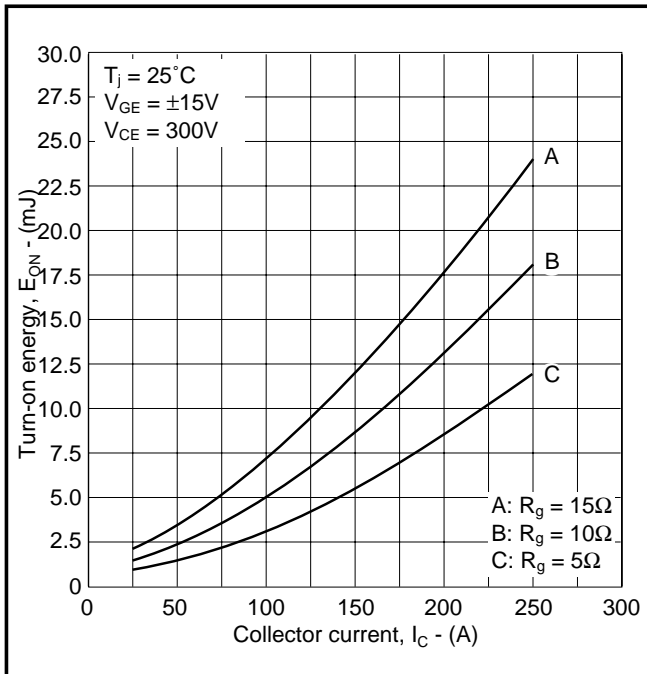

Fig.5 Typical turn-on energy vs collector current

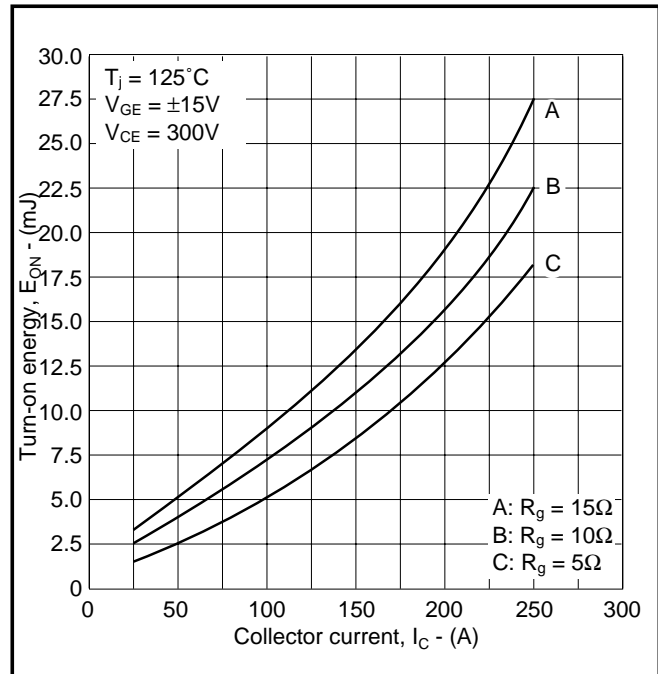

Fig.6 Typical turn-on energy vs collector current

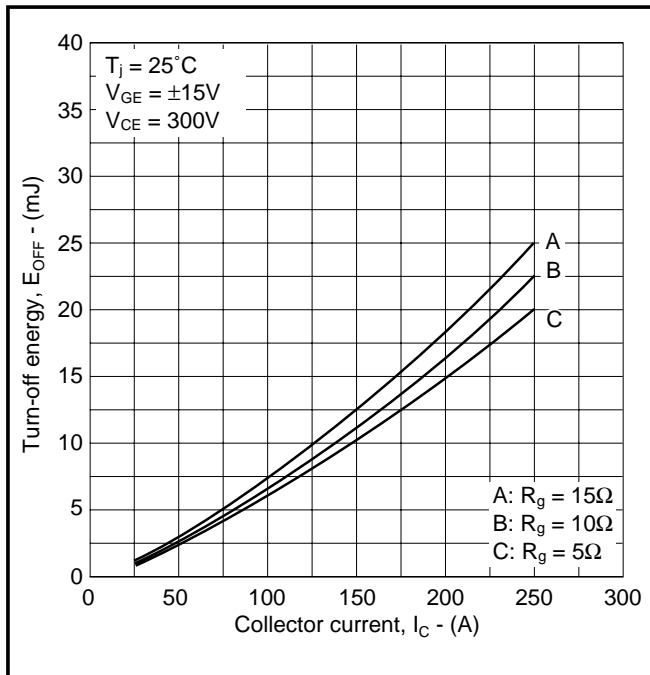

Fig.7 Typical turn-off energy vs collector current

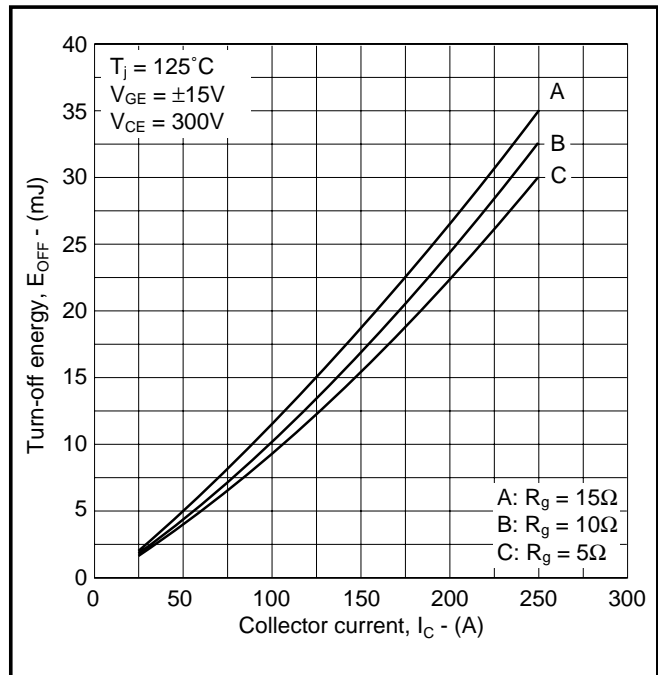

Fig.8 Typical turn-off energy vs collector current

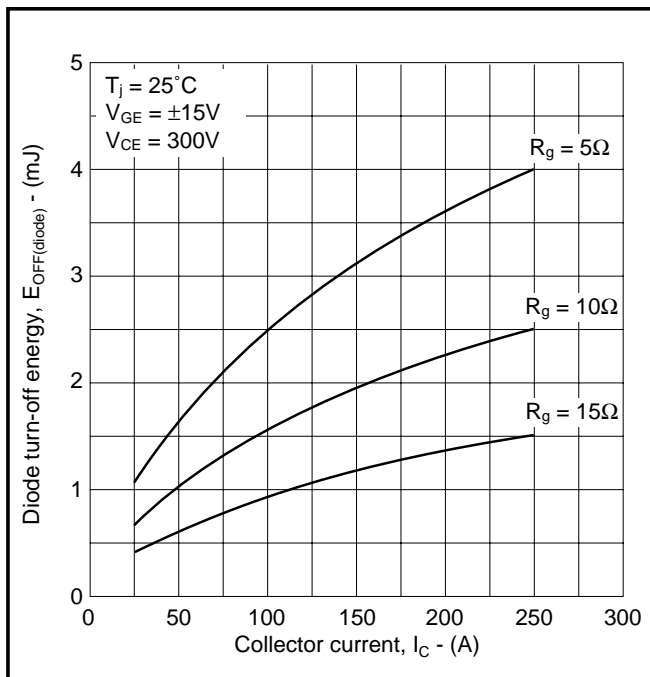

Fig.9 Typical diode turn-off energy vs collector current

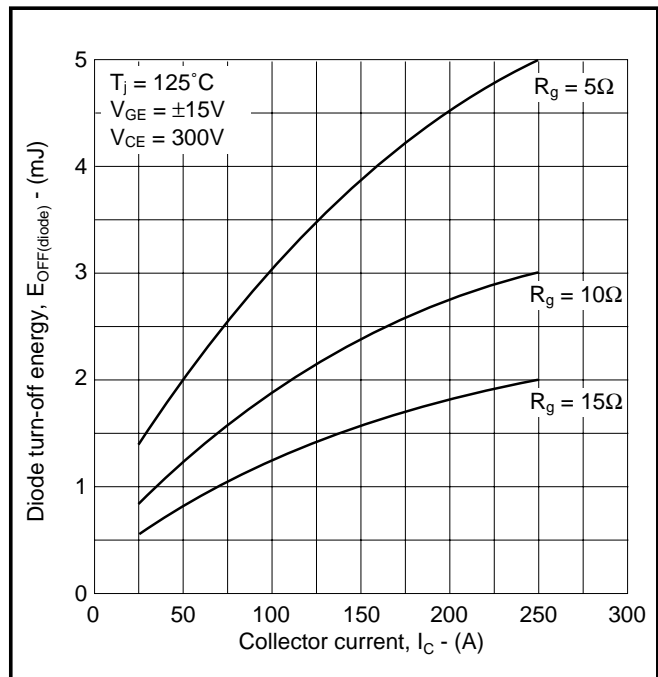
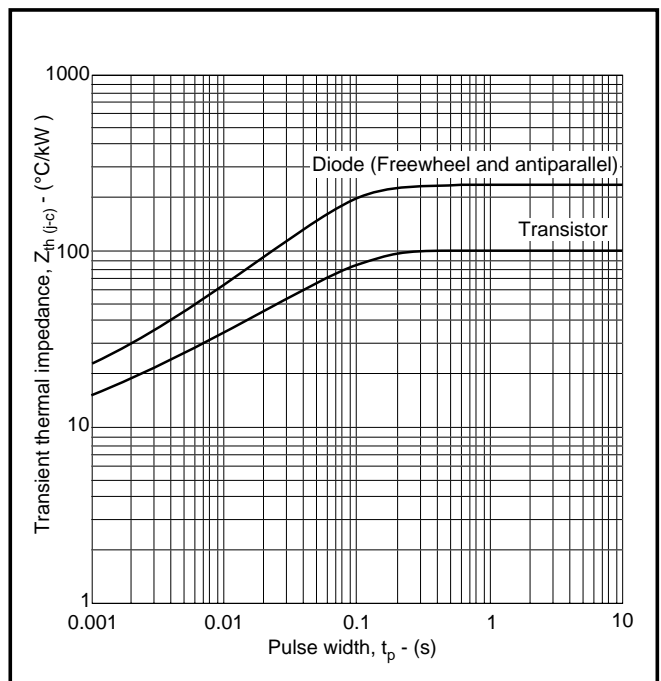
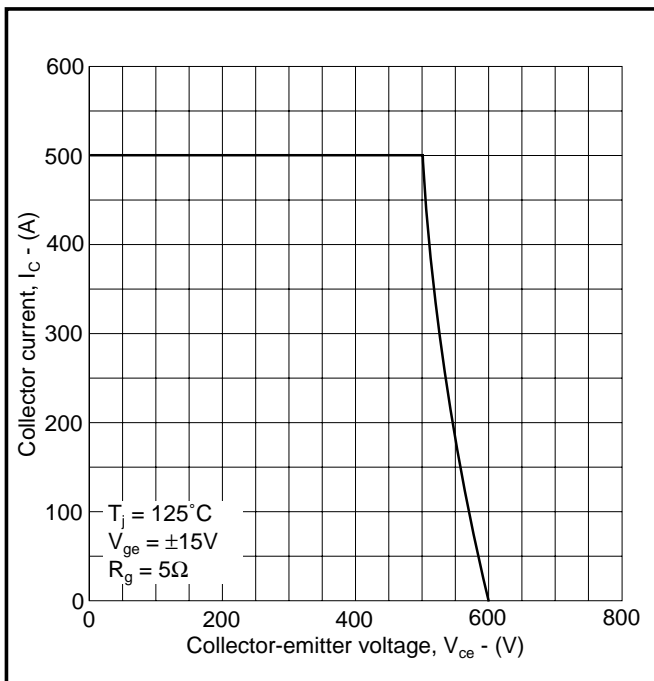
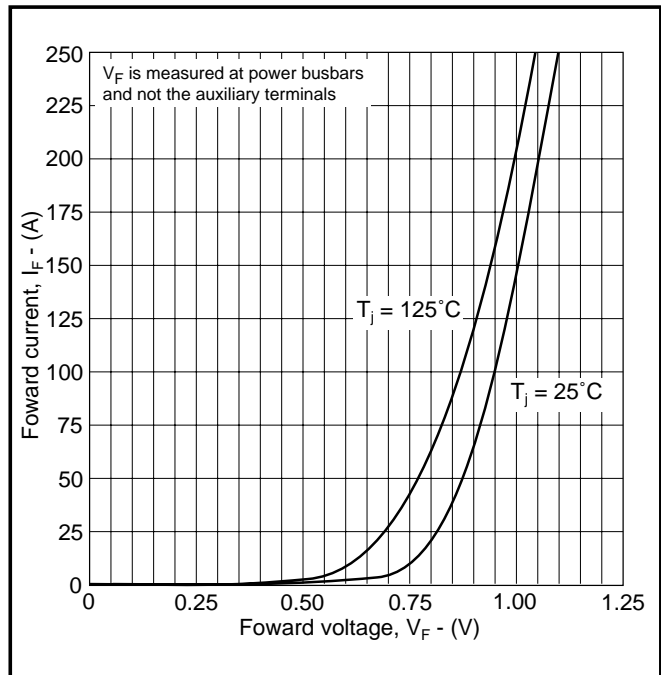
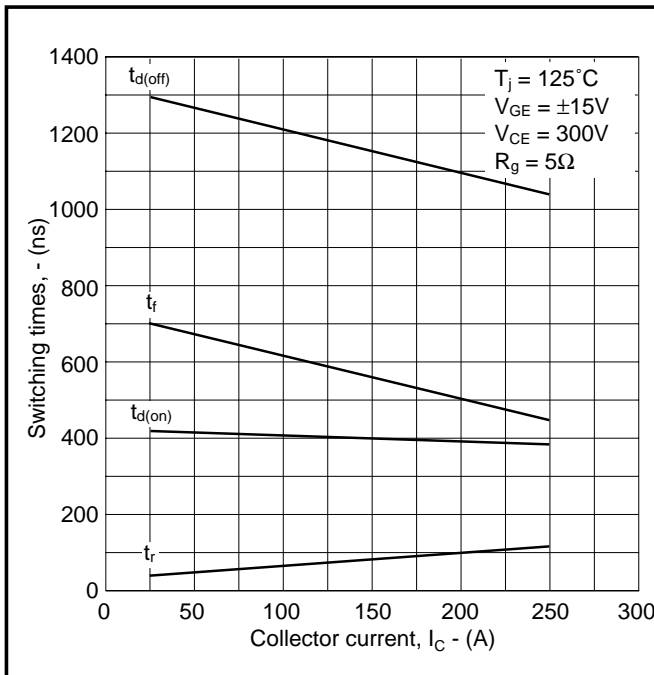

Fig.10 Typical diode turn-off energy vs collector current

Caution: This device is sensitive to electrostatic discharge. Users should follow ESD handling procedures.



PACKAGE DETAILS

For further package information please contact Customer Services. All dimensions in mm, unless stated otherwise. DO NOT SCALE.

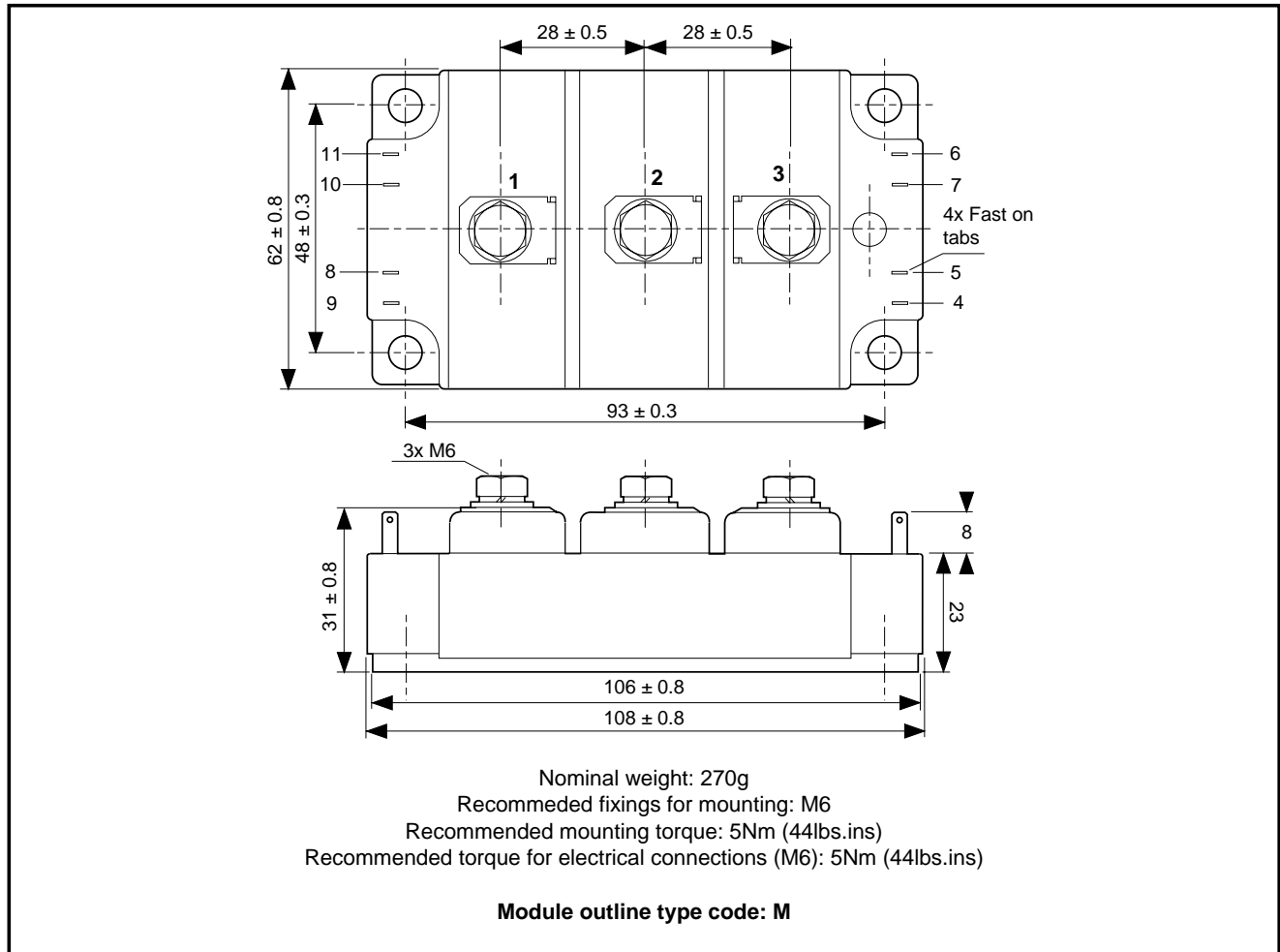

POWER ASSEMBLY CAPABILITY

The Power Assembly group was set up to provide a support service for those customers requiring more than the basic semiconductor, and has developed a flexible range of heatsink and clamping systems in line with advances in device voltages and current capability of our semiconductors.

We offer an extensive range of air and liquid cooled assemblies covering the full range of circuit designs in general use today. The Assembly group offers high quality engineering support dedicated to designing new units to satisfy the growing needs of our customers.

Using the latest CAD methods our team of design and applications engineers aim to provide the Power Assembly Complete Solution (PACs).

HEATSINKS

The Power Assembly group has its own proprietary range of extruded aluminium heatsinks which have been designed to optimise the performance of Dynex semiconductors. Data with respect to air natural, forced air and liquid cooling (with flow rates) is available on request.

For further information on device clamps, heatsinks and assemblies, please contact your nearest sales representative or Customer Services.



<http://www.dynexsemi.com>

e-mail: power_solutions@dynexsemi.com

HEADQUARTERS OPERATIONS
DYNEX SEMICONDUCTOR LTD
Doddington Road, Lincoln.
Lincolnshire. LN6 3LF. United Kingdom.
Tel: +44-(0)1522-500500
Fax: +44-(0)1522-500550

CUSTOMER SERVICE
Tel: +44 (0)1522 502753 / 502901. Fax: +44 (0)1522 500020

SALES OFFICES
Benelux, Italy & Switzerland: Tel: +33 (0)1 64 66 42 17. Fax: +33 (0)1 64 66 42 19.
France: Tel: +33 (0)2 47 55 75 52. Fax: +33 (0)2 47 55 75 59.
Germany, Northern Europe, Spain & Rest Of World: Tel: +44 (0)1522 502753 / 502901.
Fax: +44 (0)1522 500020
North America: Tel: (949) 733-3005. Fax: (949) 733-2986.

These offices are supported by Representatives and Distributors in many countries world-wide.
© Dynex Semiconductor 2002 TECHNICAL DOCUMENTATION – NOT FOR RESALE. PRODUCED IN UNITED KINGDOM

Datasheet Annotations:

Dynex Semiconductor annotate datasheets in the top right hand corner of the front page, to indicate product status. The annotations are as follows:-

Target Information: This is the most tentative form of information and represents a very preliminary specification. No actual design work on the product has been started.

Preliminary Information: The product is in design and development. The datasheet represents the product as it is understood but details may change.

Advance Information: The product design is complete and final characterisation for volume production is well in hand.

No Annotation: The product parameters are fixed and the product is available to datasheet specification.

This publication is issued to provide information only which (unless agreed by the Company in writing) may not be used, applied or reproduced for any purpose nor form part of any order or contract nor to be regarded as a representation relating to the products or services concerned. No warranty or guarantee express or implied is made regarding the capability, performance or suitability of any product or service. The Company reserves the right to alter without prior notice the specification, design or price of any product or service. Information concerning possible methods of use is provided as a guide only and does not constitute any guarantee that such methods of use will be satisfactory in a specific piece of equipment. It is the user's responsibility to fully determine the performance and suitability of any equipment using such information and to ensure that any publication or data used is up to date and has not been superseded. These products are not suitable for use in any medical products whose failure to perform may result in significant injury or death to the user. All products and materials are sold and services provided subject to the Company's conditions of sale, which are available on request.

All brand names and product names used in this publication are trademarks, registered trademarks or trade names of their respective owners.
