

ChargePump™ High-Current Charge Pump with S²Cwire™ Control and Dual LDO for Backlight and Flash

General Description

The AAT2842 is a highly integrated charge pump with dual linear regulators optimized for systems operating with lithium-ion/polymer batteries. The charge pump provides power for both white LED backlight/keypad and flash. Up to four backlight LEDs can be driven at up to 30mA each and keypad LEDs can be driven using lower currents set by the S²Cwire interface. In addition, up to four flash LEDs can be driven with up to 600mA total. Two separate S²Cwire™ (Simple Serial Control™) serial digital interfaces are used to enable, disable, and set the current to one of 16 levels for both backlight and flash LEDs. Backlight/keypad and flash current settings are also controlled through external resistors for increased versatility with reduced accuracy and matching. Backlight/keypad current matching is 1% for uniform display brightness, and flash current matching is 4% for uniform power dissipation. An internal flash timer set by an external capacitor protects the flash LED should a fault occur.

The AAT2842 offers two high-performance MicroPower™ low dropout (LDO) linear regulators. A single enable input controls both regulators and each supplies up to 200mA to the load. Both LDOs consume only 85µA quiescent current, making them ideal for battery-operated applications.

The AAT2842 is equipped with built-in short-circuit and over-temperature protection. The charge pump soft-start circuitry prevents excessive inrush current at start-up. The product is available in a Pb-free, space-saving TQFN44-28 package and operates over the -40°C to +85°C ambient temperature range.

Features

- V_{IN} Range: 2.7V to 5.5V
- Tri-Mode Charge Pump:
 - Drives up to Four Backlight/Keypad and Four Flash LEDs
 - Separate S²Cwire Control for Backlight/Keypad and Flash Currents
 - Backlight/Keypad and Flash Current Set by Separate External Resistors
 - Flash Timer Set with External Capacitor
 - Up to 2MHz Switching Frequency
- Two Linear Regulators:
 - 200mA Output Current
 - 200mV Dropout
 - Output Voltage Adjustable from 1.2V to V_{BATTERY}
 - Output Auto-Discharge for Fast Shutdown
 - 85µA Quiescent Current
- Built-In Thermal Protection
- Automatic Soft Start
- -40°C to +85°C Temperature Range
- Available in 4x4mm TQFN44-28 Package

Applications

- Camera-Enabled Mobile Devices
- Digital Still Cameras
- Multimedia Mobile Phones

Typical Application

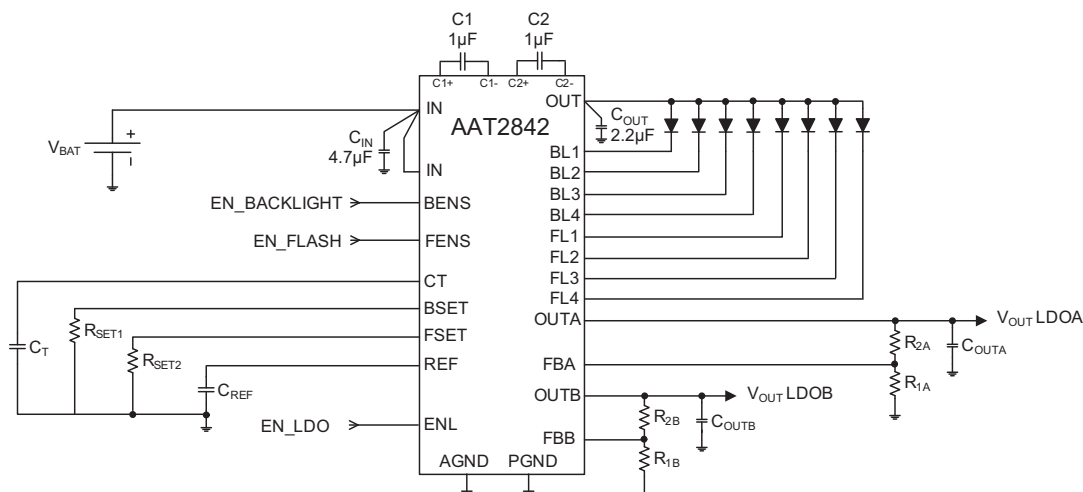

Pin Descriptions

Pin #	Symbol	Description
1	BL1	Backlight LED 1 current sink. BL1 controls the current through Backlight LED 1. Connect the cathode of Backlight LED 1 to BL1. If not used, connect BL1 to OUT.
2	BSET	Backlight current setting input. A 280kΩ resistor from BSET to AGND sets the maximum backlight current to 30mA.
3	FSET	Flash current setting input. A 280kΩ resistor from FSET to AGND sets the maximum flash current to 150mA.
4	AGND	Analog ground. Connect AGND to PGND at a single point as close to the AAT2842 as possible.
5	CT	Flash timer control capacitor input. Connect a capacitor from CT to AGND to set the flash timer. A 100nF capacitor sets the timer to 1s.
6	REF	Reference output. For low noise operation, bypass REF to AGND with capacitor. Typically, a 0.1μF ceramic capacitor provides sufficient noise reduction.
7	FBB	Feedback input for LDOB. FBB measures the output voltage of LDOB. Connect a resistive voltage divider from the output of LDOB to FBB. FBB feedback regulation voltage is 1.2V.
8	OUTB	LDOB regulated voltage output. OUTB is the voltage output of low dropout regulator B. Bypass OUTB to AGND with a 2.2μF or larger ceramic capacitor as close to the AAT2842 as possible.
9, 18	IN	Power input. Connect IN to the input source voltage. Bypass IN to PGND with a 4.7μF or larger ceramic capacitor as close to the AAT2842 as possible.
10	FBA	Feedback input for LDOA. FBA measures the output voltage of LDOA. Connect a resistive voltage divider from the output of LDOA to FBA. FBA feedback regulation voltage is 1.2V.
11	OUTA	LDOA regulated voltage output. OUTA is the voltage output of low dropout regulator A. Bypass OUTA to AGND with a 2.2μF or larger ceramic capacitor as close to the AAT2842 as possible.
12	C1-	Negative node of charge pump capacitor 1.
13	C1+	Positive node of charge pump capacitor 1. Connect a 1μF ceramic capacitor from C1+ to C1-.
14	OUT	Charge pump output. OUT is the output of the charge pump and supplies current to the backlight and flash LEDs. Connect the backlight and flash LED anodes to OUT. Bypass OUT to PGND with a 2.2μF or larger capacitor as close to the AAT2842 as possible.
15	ENL	LDO enable input. ENL turns on or off the low dropout regulators. Drive ENL high to turn on the regulators, drive it low to turn them off.
16	C2+	Positive node of charge pump capacitor 2. Connect a 1μF ceramic capacitor from C2+ to C2-.
17	C2-	Negative node of charge pump capacitor 2.
19	PGND	Power ground. Connect AGND to PGND at a single point as close to the AAT2842 as possible.
20	FL4	Flash LED 4 current sink. FL4 controls the current through Flash LED 4. Connect the cathode of Flash LED 4 to FL4. If not used, connect FL4 to OUT.
21	FL3	Flash LED 3 current sink. FL3 controls the current through Flash LED 3. Connect the cathode of Flash LED 3 to FL3. If not used, connect FL3 to OUT.
22	FL2	Flash LED 2 current sink. FL2 controls the current through Flash LED 2. Connect the cathode of Flash LED 2 to FL2. If not used, connect FL2 to OUT.
23	FL1	Flash LED 1 current sink. FL1 controls the current through Flash LED 1. Connect the cathode of Flash LED 1 to FL1. If not used, connect FL1 to OUT.
24	FENS	Flash enable and serial control input. FENS is the on/off control for the flash and the S ² Cwire input to serially control the flash LED brightness relative to the maximum current set by the resistor at FSET.
25	BENS	Backlight enable and serial control input. BENS is the on/off control for the backlight and the S ² Cwire input to serially control the backlight LED brightness relative to the maximum current set by the resistor at BSET.
26	BL4	Backlight LED 4 current sink. BL4 controls the current through Backlight LED 4. Connect the cathode of Backlight LED 4 to BL4. If not used, connect BL4 to OUT.
27	BL3	Backlight LED 3 current sink. BL3 controls the current through Backlight LED 3. Connect the cathode of Backlight LED 3 to BL3. If not used, connect BL3 to OUT.
28	BL2	Backlight LED 2 current sink. BL2 controls the current through Backlight LED 2. Connect the cathode of Backlight LED 2 to BL2. If not used, connect BL2 to OUT.
EP		Exposed paddle (bottom); connect to PGND as closely as possible to the device.

Pin Configuration

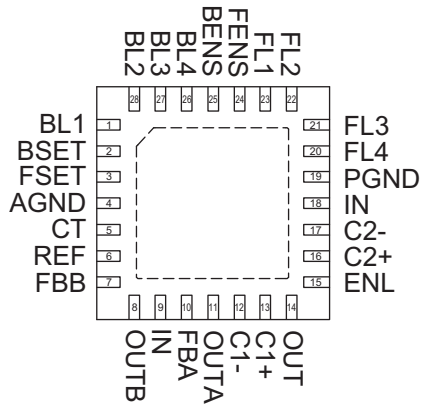
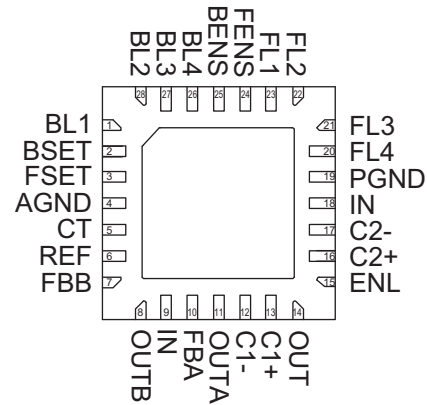
**TQFN44-28-0.4
(Top View)**

**TQFN44-28-0.45
(Top View)**

N.B. Not recommended for new designs.

Absolute Maximum Ratings¹

Symbol	Description	Value	Units
	IN, OUT, FL1, FL2, FL3, FL4, BL1, BL2, BL3, BL4 Voltage to AGND	-0.3 to 6.0	V
	C1+, C1-, C2+, C2- Voltage to AGND	-0.3 to V _{OUT} + 0.3	V
	BSET, FSET, CT, FBB, OUTA, FBA, OUTB, ENL, REF, FENS, BENS Voltage to AGND	-0.3 to V _{IN} + 0.3	V
	PGND Voltage to AGND	-0.3 to 0.3	V
T _J	Operating Junction Temperature Range	-40 to 150	°C
T _{LEAD}	Maximum Soldering Temperature (at leads, 10 sec)	300	°C

Thermal Information²

Symbol	Description	Value	Units
P _D	Maximum Power Dissipation ³	2	W
θ _{JA}	Maximum Thermal Resistance	50	°C/W

1. Stresses above those listed in Absolute Maximum Ratings may cause permanent damage to the device. Functional operation at conditions other than the operating conditions specified is not implied. Only one Absolute Maximum Rating should be applied at any one time.
 2. Mounted on an FR4 circuit board.
 3. Derate 20mW/°C above 40°C ambient temperature.

ChargePump™ High-Current Charge Pump with S²Cwire™ Control and Dual LDO for Backlight and Flash
Electrical Characteristics¹

$V_{IN} = 3.6V$; $C_{IN} = 4.7\mu F$; $C_{OUT} = 2.2\mu F$; $C_1 = C_2 = 1.0\mu F$; $R_{BSET} = R_{FSET} = 280k\Omega$; $T_A = -40^\circ C$ to $+85^\circ C$, unless otherwise noted. Typical values are at $T_A = 25^\circ C$.

Symbol	Description	Conditions	Min	Typ	Max	Units
V_{IN}	IN Operating Voltage Range		2.7		5.5	V
$I_{IN(Q)}$	IN Operating Current	1X Mode, $3.0V \leq V_{IN} \leq 5.5V$, Active, No Load; ENL = AGND, FENS = BENS = IN			1.0	mA
		1.5X Mode, $3.0V \leq V_{IN} \leq 5.5V$, Active, No Load; ENL = AGND, FENS = BENS = IN			3.0	
		2X Mode, $3.0V \leq V_{IN} \leq 5.5V$, Active, No Load; ENL = AGND, FENS = BENS = IN			5.0	
		$R_{BSET} = 280k\Omega$, Data 1, 1X Mode		50	μA	
$I_{IN(SHDN)}$	IN Shutdown Current	ENL = BENS = FENS = AGND, $T_A = 25^\circ C$			5.0	μA
T_{SD}	Over-Temperature Shutdown Threshold			140		$^\circ C$
$T_{SD(HYS)}$	Over-Temperature Shutdown Hysteresis			15		$^\circ C$
Charge Pump Section						
I_{OUT}	OUT Maximum Output Current			600		mA
$V_{IN(TH_H)}$	Charge Pump Mode Hysteresis	Data 1		350		mV
f_{OSC}	Charge Pump Oscillator Frequency			2		MHz
t_{SS}	Charge Pump Soft-Start Delay	OUT = 0V to V_{BAT}		350		μs
Backlight LED Outputs, S²Cwire Data = 1						
$I_{BL-(MAX)}$	BL1-BL4 Maximum Current	$V_{IN} - V_F = 1.5V$	27	30	33	mA
$\Delta I_{(BL-)}$	BL1-BL4 Current Matching ²	$V_{IN} - V_F = 1.5V$		0.5	1	%
$V_{BL-(TH)}$	BL1-BL4 Charge Pump Mode Transition Threshold			150		mV
V_{BSET}	R_{BSET} Pin Voltage			0.7		V
Backlight LED Outputs, S²Cwire Data = 7						
$I_{BL-(MAX)}$	BL1-BL4 Maximum Current	$V_{IN} - V_F = 1.5V$	8.6	9.6	10.6	mA
$\Delta I_{(BL-)}$	BL1-BL4 Current Matching ²	$V_{IN} - V_F = 1.5V$			2	%
$V_{BL-(TH)}$	BL1-BL4 Charge Pump Mode Transition Threshold			60		mV
Flash LED Outputs, S²Cwire Data = 1						
$I_{FL-(MAX)}$	FL1-FL4 Maximum Current	$V_{IN} - V_F = 1.5V$	135	150	165	mA
$\Delta I_{(FL-)}$	FL1-FL4 Current Matching ²	$V_{IN} - V_F = 1.5V$		1	4	%
$V_{FL-(TH)}$	FL1-FL4 Charge Pump Mode Transition Threshold			300		mV
V_{FSET}	R_{FSET} Pin Voltage			0.7		V

1. The AAT2842 is guaranteed to meet performance specifications over the $-40^\circ C$ to $+85^\circ C$ operating temperature range and is assured by design, characterization, and correlation with statistical process controls.

2. Current matching is defined as the deviation of any sink current from the average of all active channels.

ChargePump™ High-Current Charge Pump with S²Cwire™ Control and Dual LDO for Backlight and Flash
Electrical Characteristics¹

$V_{IN} = 3.6V$; $C_{IN} = 4.7\mu F$; $C_{OUT} = 2.2\mu F$; $C_1 = C_2 = 1.0\mu F$; $R_{BSET} = R_{FSET} = 280k\Omega$; $T_A = -40^\circ C$ to $+85^\circ C$, unless otherwise noted. Typical values are at $T_A = 25^\circ C$.

Symbol	Description	Conditions	Min	Typ	Max	Units
Enable/Set						
$V_{BENS(L)}, V_{FENS(L)}$	BENS, FENS Low Threshold				0.4	V
$V_{BENS(H)}, V_{FENS(H)}$	BENS, FENS High Threshold		1.4			V
I_{BENS}, I_{FENS}	BENS, FENS Input Leakage Current	V_{BENS} or $V_{FENS} = V_{IN} = 5V$	-1		1	μA
$T_{BENS(L)}, T_{FENS(L)}$	BENS, FENS Low Time		0.3		75	μs
$T_{BENS(H-MIN)}, T_{FENS(H-MIN)}$	BENS, FENS Minimum High Time			50		ns
$T_{BENS(H-MAX)}, T_{FENS(H-MAX)}$	BENS, FENS Maximum High Time				75	μs
$T_{BENS(OFF)}, T_{FENS(OFF)}$	BENS, FENS Off Timeout				500	μs
$T_{BENS(LAT)}, T_{FENS(LAT)}$	BENS, FENS Latch Timeout				500	μs
Linear Regulators						
V_{FBA}, V_{FBB}	FB Voltage Tolerance	$I_{OUT} = 1mA$ to $200mA$	1.17	1.2	1.23	V
I_{IN}	IN Operating Current	ENL = IN, BENS = FENS = AGND		85	150	μA
$I_{OUTA(MAX)}, I_{OUTB(MAX)}$	OUTA, OUTB Maximum Load Current		200			mA
$V_{OUTA(DO)}, V_{OUTB(DO)}$	OUTA, OUTB Dropout Voltage	$I_{OUT} = 150mA$		150	300	mV
$V_{ENL(L)}$	ENL Enable Low Voltage Threshold				0.4	V
$V_{ENL(H)}$	ENL Enable High Voltage Threshold		1.4			V
$t_{ENL(DLY)}$	ENL Enable Delay	REF = Open		15		μs
$R_{OUTA(DCHG)}, R_{OUTB(DCHG)}$	OUTA, OUTB Auto-Discharge Resistance			20		Ω
$PSRR_A, PSRR_B$	OUTA, OUTB Power Supply Rejection Ratio	$I_{OUT} = 10mA, C_{REF} = 10nF, 1kHz$		50		dB

1. The AAT2842 is guaranteed to meet performance specifications over the $-40^\circ C$ to $+85^\circ C$ operating temperature range and is assured by design, characterization, and correlation with statistical process controls.

ChargePump™ High-Current Charge Pump with S²Cwire™ Control and Dual LDO for Backlight and Flash

Typical Characteristics

$V_{IN} = 3.6V$; $C_{IN} = 4.7\mu F$; $C_{OUT} = 2.2\mu F$; $C_1 = C_2 = 1.0\mu F$; $R_{BSET} = R_{FSET} = 280k\Omega$; $T_A = -40^\circ C$ to $+85^\circ C$, unless otherwise noted. Typical values are at $T_A = 25^\circ C$.

Backlight Efficiency vs. Supply Voltage

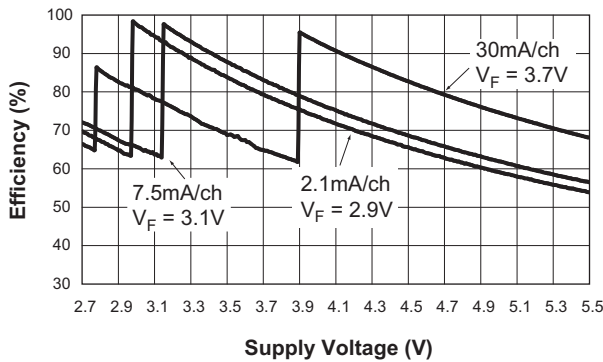

Flash Efficiency vs. Supply Voltage

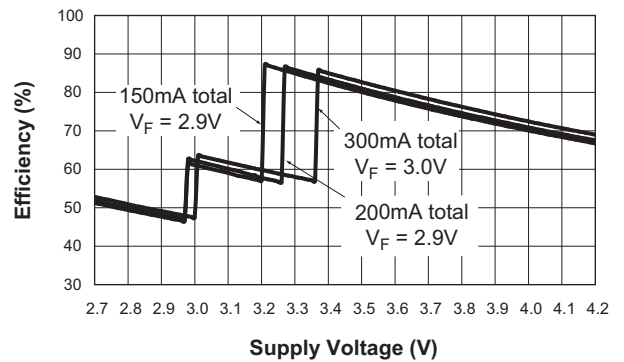

Turn On to 1X Mode Backlight
(30mA/ch; Data 1; $V_{IN} = 4.2V$)

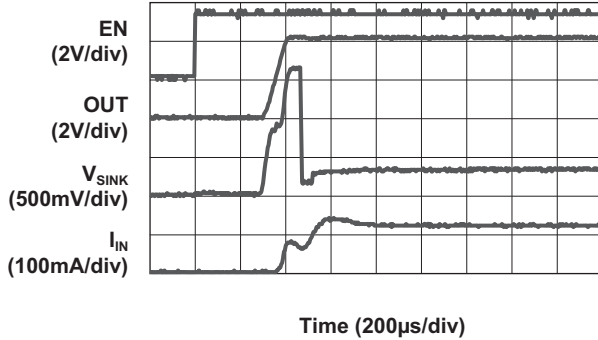

Turn On to 1.5X Mode Backlight
(30mA/ch; Data 1; $V_{IN} = 3.5V$)

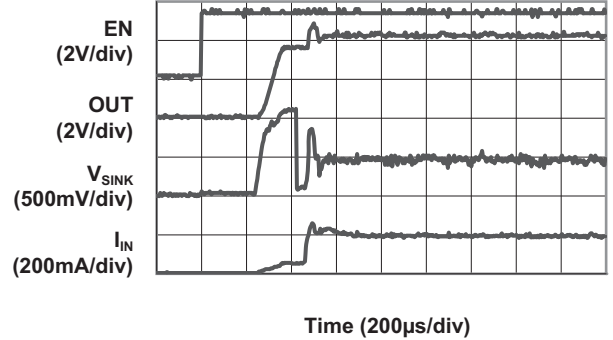

Turn On to 2X Mode Backlight
(30mA/ch; Data 1; $V_{IN} = 3.2V$)

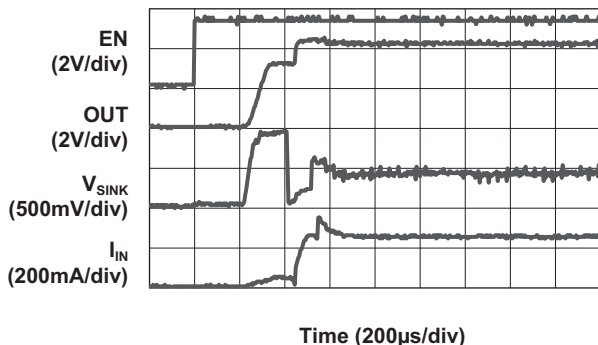

Turn Off from 1.5X Mode Backlight
(30mA/ch; Data 1)

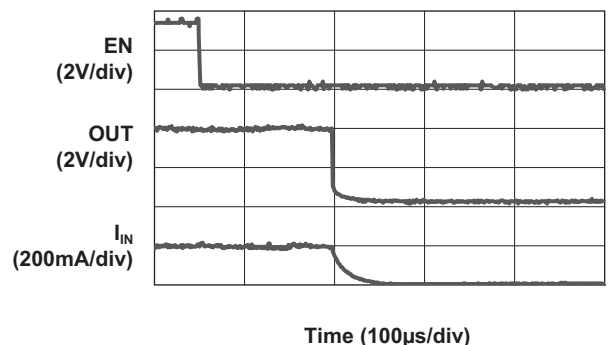

ChargePump™ High-Current Charge Pump with S²Cwire™ Control and Dual LDO for Backlight and Flash
Typical Characteristics

$V_{IN} = 3.6V$; $C_{IN} = 4.7\mu F$; $C_{OUT} = 2.2\mu F$; $C_1 = C_2 = 1.0\mu F$; $R_{BSET} = R_{FSET} = 280k\Omega$; $T_A = -40^\circ C$ to $+85^\circ C$, unless otherwise noted. Typical values are at $T_A = 25^\circ C$.

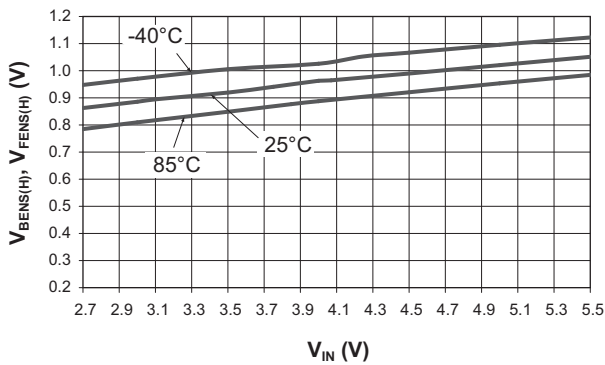
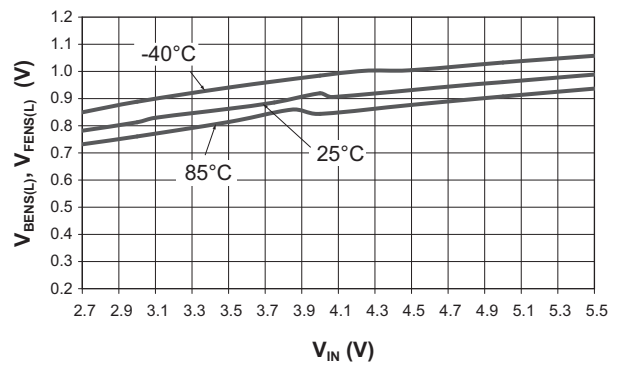
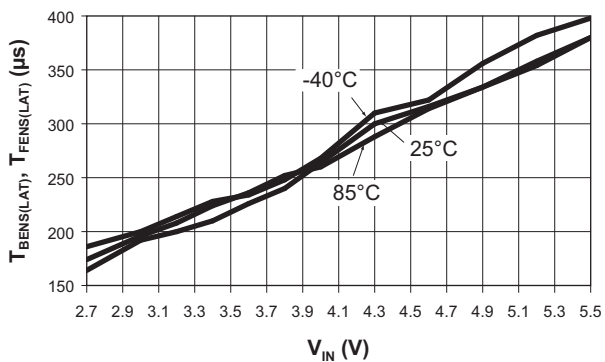
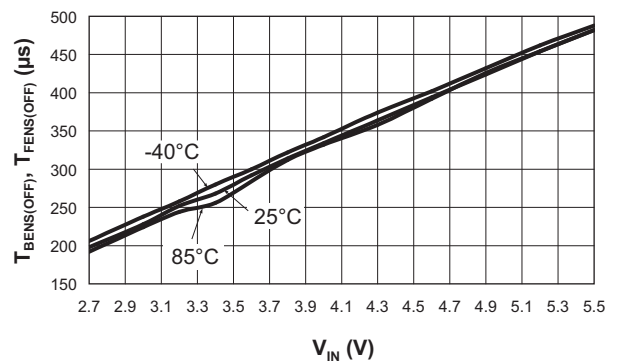
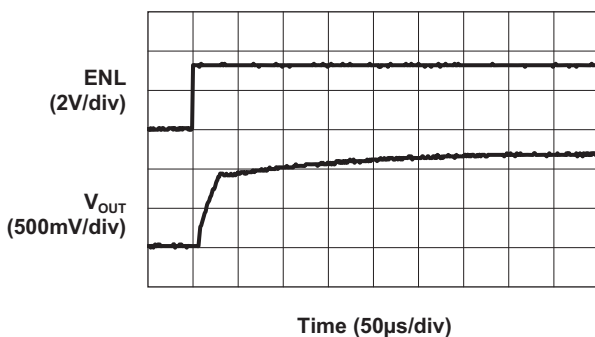
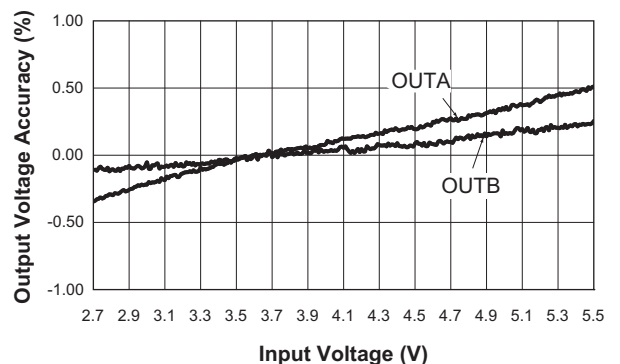
BENS, FENS High Threshold Voltage vs. Supply Voltage

BENS, FENS Low Threshold Voltage vs. Supply Voltage

BENS, FENS Latch Timeout vs. Supply Voltage

BENS, FENS Off Timeout vs. Supply Voltage

LDOs A and B Turn On Characteristic

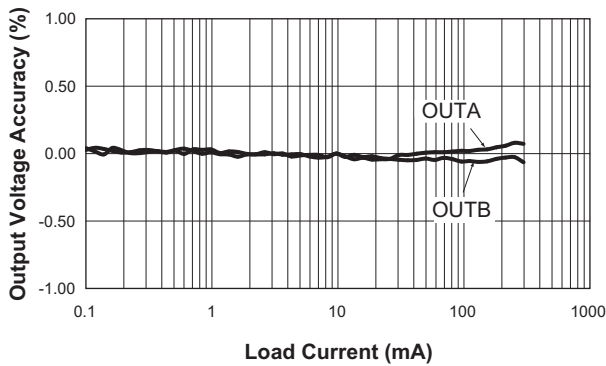
LDOs A and B Line Regulation

ChargePump™ High-Current Charge Pump with S²Cwire™ Control and Dual LDO for Backlight and Flash

Typical Characteristics

$V_{IN} = 3.6V$; $C_{IN} = 4.7\mu F$; $C_{OUT} = 2.2\mu F$; $C_1 = C_2 = 1.0\mu F$; $R_{BSET} = R_{FSET} = 280k\Omega$; $T_A = -40^\circ C$ to $+85^\circ C$, unless otherwise noted. Typical values are at $T_A = 25^\circ C$.

LDOs A and B Load Regulation



LDOs A and B Line Transient Response (10mA Load)

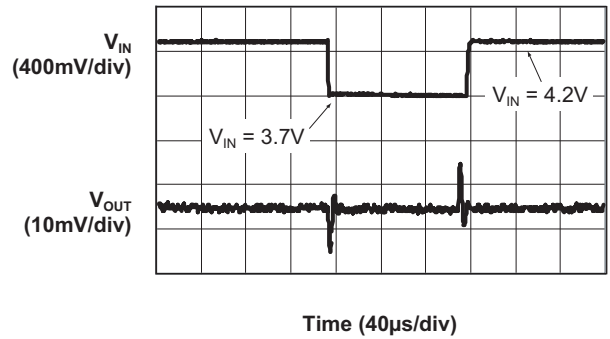

LDOA Load Transient Response (10mA to 200mA Load Step)

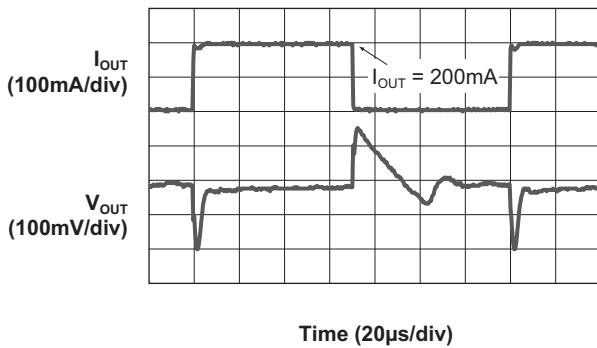

Functional Block Diagram

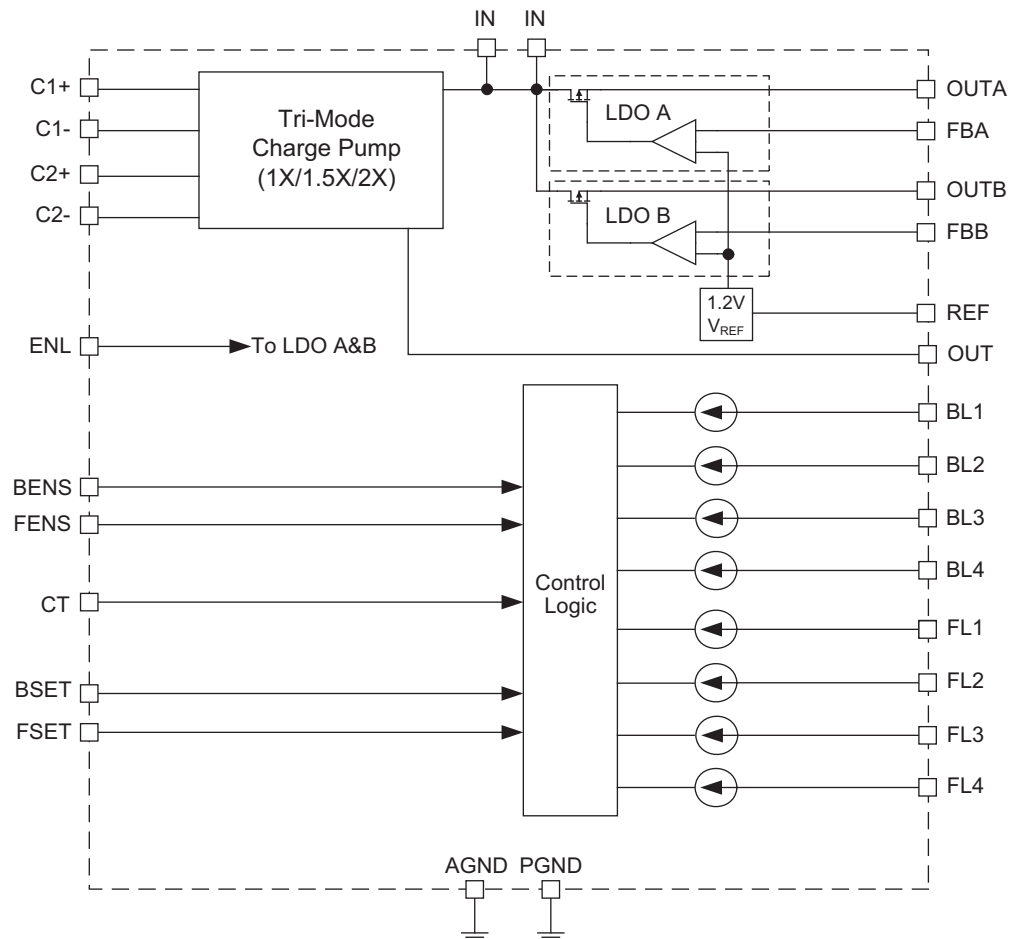

Functional Description

The AAT2842 is a highly integrated LED driver with two LDO linear regulators. The charge pump LED driver simultaneously drives the backlight and flash LEDs from a 2.7V to 5.5V input voltage. The LDO regulators operate from the same input voltage range and produce regulated output voltages as low as 1.2V.

LED Drivers

The LEDs are driven from an internal charge pump that, depending on the battery voltage and LED forward voltage, drives the LED directly from the input voltage (1X mode) or steps the input voltage up by a factor of 1.5 (1.5X mode) or 2 (2X mode). The charge pump requires only two tiny ceramic capacitors, making a more com-

pact solution than an inductor-based step-up converter solution. Each individual LED is driven by a current sink to GND allowing individual current control with high accuracy over a wide range of input voltages and LED forward voltages while maintaining high efficiency.

The charge pump is controlled by the voltage across the LED current sinks. When any one of the active current sinks starts to dropout, the charge pump goes to the next higher mode (from 1X to 1.5X or from 1.5X to 2X mode) to maintain sufficient LED voltage and keep constant LED current. The AAT2842 continuously monitors the LED forward voltages, and the input voltage determines when to reduce the charge pump mode for better efficiency. There is also a 350mV mode-transition hysteresis that prevents the charge pump from oscillating between modes.



ChargePump™ High-Current Charge Pump with S²Cwire™ Control and Dual LDO for Backlight and Flash

The backlight and flash LED currents are controlled by a combination of an external programming resistor from BSET (for backlight) or FSET (for flash) to AGND and the backlight or flash serial S²Cwire interface BENS or FENS. The programming resistor sets the maximum LED current for each channel, and the serial S²Cwire interface controls the LED current relative to the maximum.

To drive backlight LEDs with optimal absolute accuracy and channel-to-channel matching, the maximum output current is set to 30mA with a 280kΩ resistor connected at the BSET pin of the AAT2842.

Using Backlight LED Outputs for Low-Current LED Applications

The AAT2842’s backlight current outputs can be programmed to drive lower current LEDs, such as those used for keypad applications. For best low-current accuracy and matching, the preferred method is to use a 280kΩ resistor for R_{BSET} and then set the desired current output using the product’s S²Cwire interface, as shown in Table 1.

If any one of the current sinks is not used, connect the unused current sink to OUT. The current controller monitors the current sink voltage and, if it is connected to OUT, then it is assumed that the current sink is not used or that the LED is shorted, and the controller turns off that current sink.

S²Cwire Serial Interface

The S²Cwire serial interface records rising edges of the EN/SET pin and decodes them into 16 different states. The S²Cwire interface has flexible timing; data can be clocked-in at speeds greater than 1MHz or much slower, such as 15kHz. After data is submitted, EN/SET is held high to latch the data.

Once EN/SET has been held in the logic high state for time T_{LAT}, the programmed current becomes active and the internal data register is reset to zero. For subsequent current level programming, the number of rising edges corresponding to the desired code must be entered on the EN/SET pin.

The AAT2842 features separate control interfaces for the backlight and flash current control. The backlight current features 16 current steps, each as a percentage of the maximum backlight current set by the B_{SET} resistance. The flash has 16 current level settings, again as a percentage of the maximum flash current set by the F_{SET} resistance (see Tables 1 and 2). Initiating a flash current also initiates the flash timer which is programmed via an external capacitor C_T.

Calculate the flash time T by the following equation:

$$T = 10 \cdot C_T$$

where T is in seconds and C_T is in μF.

For example, for a 0.1μF capacitor:

$$T = 10 \cdot 0.1\mu F = 1s$$

To disable the flash timer, connect C_T to AGND.

Data	BL% of B _{SET}
1	100
2	82
3	70
4	59
5	49.2
6	41.0
7	33.0
8	28.2
9	23.5
10	18.7
11	15.4
12	12.3
13	7.7
14	4.1
15	2.4
16	0.2

Table 1: Backlight Current Register: BL1-BL4 (R_{BSET} = 280kΩ).

Data	FL% of F _{SET}
1	100
2	81
3	72
4	66
5	60
6	52.5
7	46.2
8	41.4
9	36.6
10	31.7
11	28.5
12	25.0
13	21.7
14	18.4
15	16.7
16	15.0

Table 2: Flash Current Register: FL1-FL4
(R_{FSET} = 280kΩ).

Shutdown

Since the sink switches are the only power returns for all loads, there is no leakage current when all of the sink switches are disabled. To activate the shutdown mode, hold both the BENS and FENS inputs low for longer than T_{BENS(OFF)} or T_{FENS(OFF)} (500µs). In this state, the AAT2842 typically draws less than 1µA from the input. Data and address registers are reset to 0 in shutdown.

Low Dropout Regulators

The AAT2842 includes two LDO linear regulators. The regulators run from the same 2.7V to 5.5V input voltage as the charge pump. The regulators use a single on/off control input, ENL. The LDO output voltages are set through a resistive voltage divider from the output (OUTA or OUTB) to the feedback input (FBA or FBB). The ratio of resistor values determines the LDO output voltage. The low 200mV dropout voltage at 200mA load current allows the regulator to maintain output voltage regulation.

Each LDO regulator can supply a continuous load current up to 200mA. Both LDOs include current limiting and thermal overload protection to prevent damage to the load or to the LDOs.

Applications Information

LDO Output Voltage Programming

The output voltages for LDOA and LDOB are programmed by an external resistor divider network. As shown in Figure 1, the selection of R1 and R2 is a straightforward matter.

R1 is chosen by considering the tradeoff between the feedback network bias current and resistor value. Higher resistor values allow stray capacitance to become a larger factor in circuit performance whereas lower resistor values increase bias current and decrease efficiency.

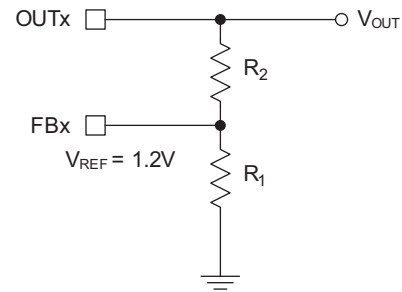

Figure 2: Selection of External Resistors.

To select appropriate resistor values, first choose R1 such that the feedback network bias current is reasonable. Then, according to the desired V_{OUT}, calculate R2 according to the equation below. An example calculation follows.

R1 is chosen to be 120K, resulting in a small feedback network bias current of 1.2V/120K = 10µA. The desired output voltage is 1.8V. From this information, R2 is calculated from the equation below.

$$R_2 = \frac{R_1(V_{OUT} - 1.2V)}{1.2V}$$

The result is R2 = 60K. Since 60K is not a standard 1% value, 60.4K is selected. From this example calculation, for V_{OUT} = 1.8V, use R1 = 120K and R2 = 60.4K. Example output voltages and corresponding resistor values are provided in Table 3.

R2 Standard 1% Values (R1 = 120K)	
V _{OUT} (V)	R2 (Ω)
2.8	160K
2.5	130K
2.0	79.6K
1.8	60.4K
1.5	30.1K

Table 3: Example Output Voltages and Corresponding Resistor Values.

Altering the Maximum LED Current Level from 30mA for Backlight and 150mA for Flash

The value of R_{BSET} determines the maximum LED current level for the backlight section. In the typical application, selecting R_{BSET} = 280kΩ results in 30mA/channel LED current. From this reference point, the maximum current level can be modified by calculating an alternative R_{BSET} value:

$$R_{BSET} = \frac{280K \cdot 30mA}{I_{BMAX}} \Omega$$

This is illustrated graphically in Figure 2.

Maximum Backlight LED Current vs. R_{BSET}

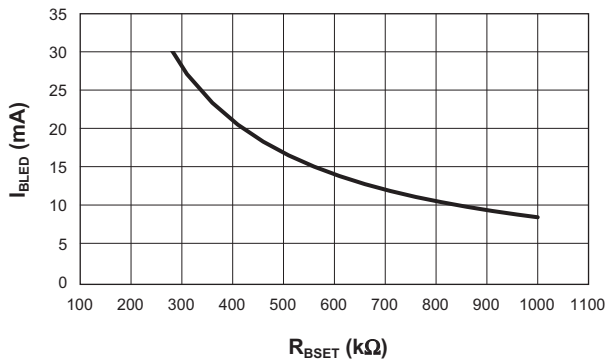

Figure 2: Maximum LED Current vs R_{BSET}.

Similarly, the value of R_{FSET} determines the maximum LED current level for the flash section. In the typical application, selecting R_{FSET} = 280kΩ results in 150mA/channel LED current. From this reference point, the maximum current level can be modified by calculating an alternative R_{FSET} value:

$$R_{FSET} = \frac{150mA \cdot 280k\Omega}{I_{FLED(MAX)}}$$

This is illustrated graphically in Figure 3.

Maximum Flash LED Current vs. R_{FSET}

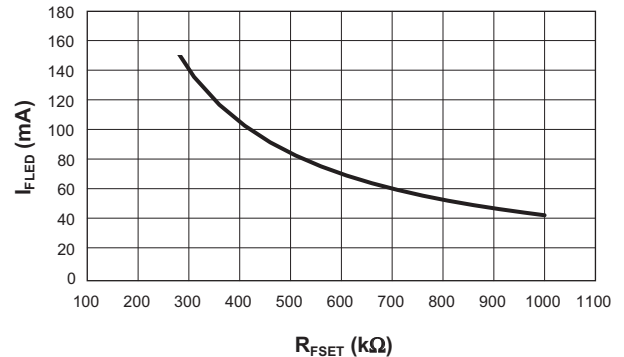

Figure 3: Maximum Flash Current vs. R_{FSET}.

Selection of set resistor values outside of the typical application must be carefully evaluated to ensure that the application's performance requirements can still be met.

Brightness Control Using the BSET and FSET Pins

An alternative method can be used for brightness control of the flash and/or backlight sections by utilizing the corresponding set resistor pin. By using a digital I/O port or DAC output, an alternative brightness control technique can be created for each lighting section, as shown in Figure 4.

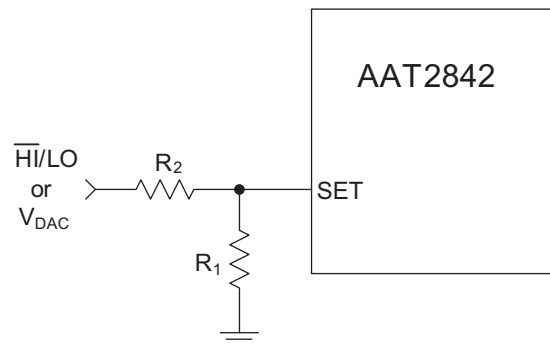

Figure 4: Brightness Control Using Either BSET or FSET Resistor Pin.

ChargePump™ High-Current Charge Pump with S²Cwire™ Control and Dual LDO for Backlight and Flash

Using an additional resistor to connect the BSET pin with a digital output provides a LO/HI control. When the digital output is asserted high, the resulting brightness level for the backlighting section is LO and the individual LED current levels are:

$$I_{LED(LO)} = 12 \cdot 10^3 \left(\frac{0.7V}{R_1 // R_2} - \frac{V_{IO}}{R_2} \right)$$

The same can be applied to the FSET pin. When the digital output is asserted high, the resulting brightness level for the flash section is LO and the individual LED current levels are:

$$I_{LED(LO)} = 60 \cdot 10^3 \left(\frac{0.7V}{R_1 // R_2} - \frac{V_{IO}}{R_2} \right)$$

When the digital output is asserted low, the resulting brightness level for the backlighting section is HI and the individual LED current levels are:

$$I_{LED(HI)} = 12 \cdot 10^3 \left(\frac{0.6V}{R_1 // R_2} \right)$$

The same can be applied to the FSET pin. When the digital output is asserted low, the resulting brightness level for the flash section is HI and the individual LED current levels are:

$$I_{LED(HI)} = 60 \cdot 10^3 \left(\frac{0.6V}{R_1 // R_2} \right)$$

Additionally, the output from a digital-to-analog converter can be used with either SET pin to control the brightness level. The result is like the equations above, where V_{IO} is replaced with V_{DAC} . Using the flash section as an example:

$$I_{LED} = 60 \cdot 10^3 \left(\frac{0.7V}{R_1 // R_2} - \frac{V_{DAC}}{R_2} \right)$$

Device Power Efficiency

The AAT2842 power conversion efficiency depends on the charge pump mode. By definition, device efficiency is expressed as the output power delivered to the LEDs divided by the total input power consumed.

$$\eta = \frac{P_{OUT}}{P_{IN}}$$

When the input voltage is sufficiently greater than the LED forward voltages, the device optimizes efficiency by operating in 1X mode. In 1X mode, the device is working as a bypass switch and passing the input supply directly to the output. By simplifying the conditions such that the LEDs have uniform V_F , the power conversion efficiency can be approximated by:

$$\eta = \frac{V_F \cdot I_{LED}}{V_{IN} \cdot I_{IN}} \approx \frac{V_F}{V_{IN}}$$

Due to the very low 1X mode quiescent current, the input current nearly equals the total output current delivered to the LEDs. Further, the low resistance bypass switch introduces negligible voltage drop from input to output.

The AAT2842 further maintains optimized performance and efficiency by detecting when the input voltage is not sufficient to sustain LED drive current. The device automatically switches to 1.5X mode when the input voltage drops too low in relation to the LED forward voltages.

In 1.5X mode, the output voltage can be boosted to 3/2 the input voltage. The 3/2 conversion ratio introduces a corresponding 1/2 increase in input current. For ideal conversion, the 1.5X mode efficiency is given by:

$$\eta = \frac{V_F \cdot I_{LED}}{V_{IN} \cdot 1.5I_{IN}} \approx \frac{V_F}{1.5 \cdot V_{IN}}$$

Similarly, when the input falls further, such that 1.5X mode can no longer sustain LED drive current, the device will automatically switch to 2X mode. In 2X mode, the output voltage can be boosted to twice the input voltage. The doubling conversion ratio introduces a corresponding doubling of the input current. For ideal conversion, the 2X mode efficiency is given by:

$$\eta = \frac{V_F \cdot I_{LED}}{V_{IN} \cdot 2I_{IN}} \approx \frac{V_F}{2 \cdot V_{IN}}$$

LED Selection

The AAT2842 is designed to drive high-intensity white LEDs. It is particularly suitable for LEDs with an operating forward voltage in the range of 4.2V to 1.5V.

The charge pump device can also drive other loads that have similar characteristics to white LEDs. For various load types, the AAT2842 provides a high-current, programmable, ideal constant current source.

ChargePump™ High-Current Charge Pump with S²Cwire™ Control and Dual LDO for Backlight and Flash

Capacitor Selection

Careful selection of the four external capacitors C_{IN} , C_1 , C_2 , and C_{OUT} is important because they will affect turn-on time, output ripple, and transient performance. Optimum performance will be obtained when low equivalent series resistance (ESR) ceramic capacitors are used. In general, low ESR may be defined as less than 100m Ω .

Ceramic composition capacitors are highly recommended over all other types of capacitors for use with the AAT2842. Ceramic capacitors offer many advantages over their tantalum and aluminum electrolytic counterparts. A ceramic capacitor typically has very low ESR, is lowest cost, has a smaller PCB footprint, and is non-polarized. Low ESR ceramic capacitors help maximize charge pump transient response. Since ceramic capacitors are non-polarized, they are not prone to incorrect connection damage.

Equivalent Series Resistance

ESR is an important characteristic to consider when selecting a capacitor. ESR is a resistance internal to a capacitor that is caused by the leads, internal connections, size or area, material composition, and ambient temperature. Capacitor ESR is typically measured in milliohms for ceramic capacitors and can range to more than several ohms for tantalum or aluminum electrolytic capacitors.

Ceramic Capacitor Materials

Ceramic capacitors less than 0.1 μ F are typically made from NPO or COG materials. NPO and COG materials generally have tight tolerance and are very stable over temperature. Larger capacitor values are usually composed of X7R, X5R, Z5U, or Y5V dielectric materials. Large ceramic capacitors are often available in lower-cost

dielectrics, but capacitors greater than 10 μ F are not typically required for AAT2842 applications.

Capacitor area is another contributor to ESR. Capacitors that are physically larger will have a lower ESR when compared to an equivalent material smaller capacitor. These larger devices can improve circuit performance when compared to an equal value capacitor in a smaller package size.

Evaluation Board User Interface

The user interface for the AAT2842 evaluation board is provided through four buttons and a number of connection terminals. The board is operated by supplying external power and pressing individual buttons or button combinations. Table 4 indicates the function of each button or button combination.

To power-on the board, connect a power supply or battery to the DC- and DC+ terminals. Close the board supply connection by positioning the J1 jumper to the ON position. A red LED indicates that power is applied.

The evaluation board is flexible so that the user can disconnect the enable lines from the microcontroller and apply external enable signals. By removing the jumpers from J2, J3, and/or J4, external enable signals can be applied to the board. External enable signals must be applied to Pin 1 of each J2, J3, or J4 terminal.

When applying external enable signals, consideration must be given to the voltage levels. The externally applied voltages cannot exceed the supply voltage that is applied to the IN pins of the device (DC+).

The LDO loads can be connected directly to the evaluation board. For adequate performance, be sure to connect the load between OUTA/OUTB and DC-, as opposed to some other GND in the system.

Evaluation Board Layout

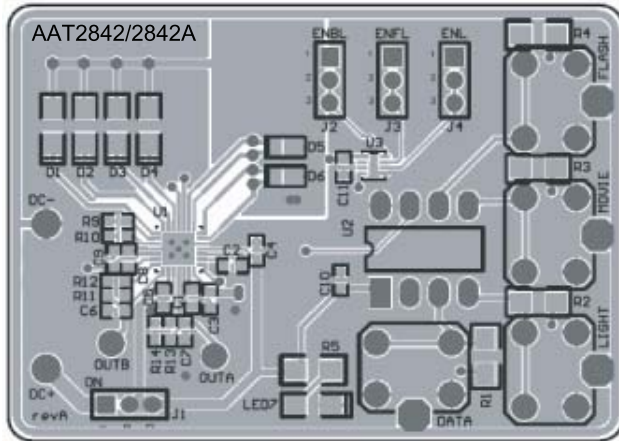

Figure 5: AAT2842 Evaluation Board Top Layer.

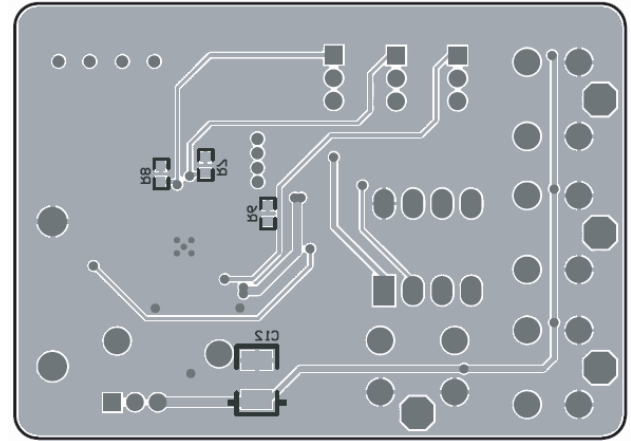

Figure 6: AAT2842 Evaluation Board Bottom Layer.

Button(s) Pushed ¹	Description
DATA	Increment the data setting for the most recently activated mode. With backlight or movie mode activated, hold down the button to auto-cycle through the brightness levels.
LIGHT	Toggle ON/OFF the backlighting section. Set the brightness level using the DATA button (defaults to Data 1).
LIGHT+DATA	Decrement the brightness setting for backlight mode. Hold down to auto-cycle.
MOVIE	Toggle ON/OFF movie mode illumination. Set the brightness level using the DATA button (defaults to Data 10).
MOVIE+DATA	Decrement the brightness setting for movie mode. Hold down to auto-cycle.
FLASH	Generate a flash pulse. Pulse duration is the lesser of 2 seconds or the CT value result. Set the brightness level using the DATA button (defaults to Data 1).
DATA+FLASH	Toggle ON/OFF the LDOs.
LIGHT+MOVIE+FLASH	Reset. Clear all data and bring all enable lines low.

Table 4: Evaluation Board User Interface.

1. The "+" indicates that these buttons are pressed and released together.

Evaluation Board Schematics

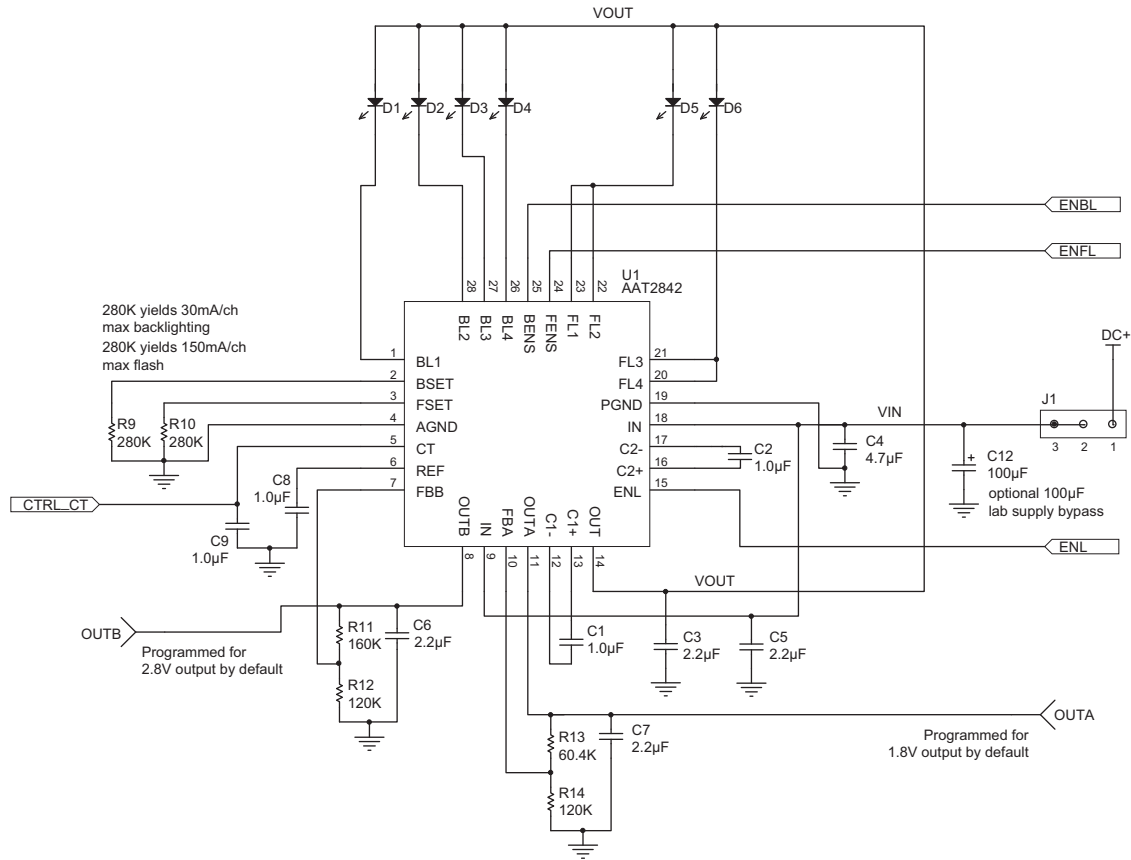
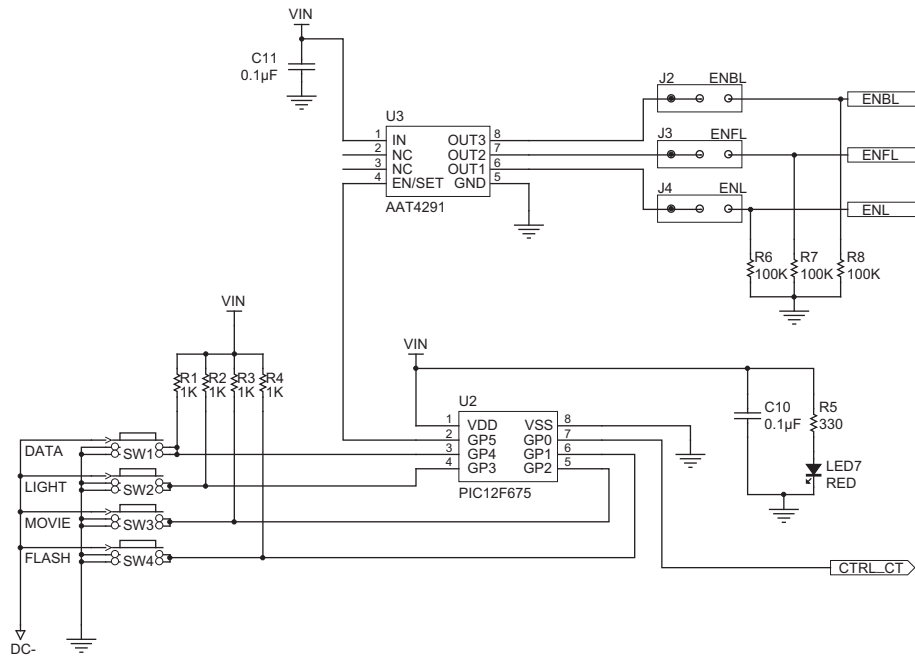

Figure 7: AAT2842 Section Schematic.

Figure 8: MCU and I/O Expander Section Schematic.

Evaluation Board Component Listing

Component	Part Number	Description	Manufacturer
U1	AAT2842INJ-EE-T1, AAT2842IBJ-EE-T1	High-Current Charge Pump with S ² Cwire Control and Dual LDO for Backlight and Flash	AnalogicTech
U2	PIC12F675	8-bit CMOS, FLASH MCU; 8-pin PDIP	Microchip
U3	AAT4291IJS-1-T1	I/O Expander	AnalogicTech
D1 - D4	LW M673	Mini TOPLED White LED; SMT	OSRAM
D5, D6	LXCL-PWF1	Luxeon Flash LED	Lumileds
C1, C2, C10	GRM18x	1.0µF, 10V, X5R, 0603, Ceramic	Murata
C3, C5, C6, C7	GRM18x	2.2µF, 10V, X5R, 0603, Ceramic	Murata
C4	GRM18x	4.7µF, 10V, X5R, 0603, Ceramic	Murata
C8, C9, C11	GRM18x	0.1µF, 16V, X7R, 0603, Ceramic	Murata
C12	TAJBx	100µF, 10V, 10µA, Tantalum	AVX
R1 - R4	Chip Resistor	1K, 5%, 1/4W; 1206	Vishay
R5	Chip Resistor	330, 5%, 1/4W; 1206	Vishay
R6 - R8	Chip Resistor	100K, 5%, 1/4W; 1206	Vishay
R9, R10	Chip Resistor	280K, 1%, 1/10W; 0603	Vishay
R11	Chip Resistor	160K, 1%, 1/10W; 0603	Vishay
R12, R14	Chip Resistor	120K, 1%, 1/10W; 0603	Vishay
R13	Chip Resistor	60.4K, 1%, 1/10W; 0603	Vishay
J1 - J4	PRPN401PAEN	Conn. Header, 2mm Zip	Sullins Electronics
LED7	CMD15-21SRC/TR8	Red LED; 1206	Chicago Miniature Lamp
SW1 - SW4	PTS645TL50	Switch Tact, SPST, 5mm	ITT Industries



ChargePump™ High-Current Charge Pump with S²Cwire™ Control and Dual LDO for Backlight and Flash

Ordering Information

Package	Marking ¹	Part Number (Tape and Reel) ²	Comments
TQFN44-28-0.45	TGXYY	AAT2842IBJ-EE-T1	Not recommended for new designs
TQFN44-28-0.4	XUXYY	AAT2842INJ-EE-T1	Recommended for new designs



All AnalogicTech products are offered in Pb-free packaging. The term “Pb-free” means semiconductor products that are in compliance with current RoHS standards, including the requirement that lead not exceed 0.1% by weight in homogeneous materials. For more information, please visit our website at <http://www.analogictech.com/about/quality.aspx>.

Legend	
Voltage	Code
1.2	E

1. XYY = assembly and date code.
 2. Sample stock is generally held on part numbers listed in **BOLD**.

Package Information¹

TQFN44-28-0.4

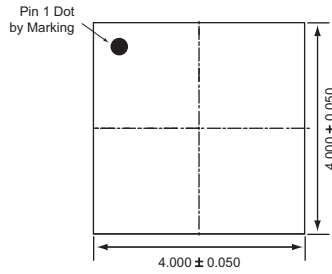

Top View

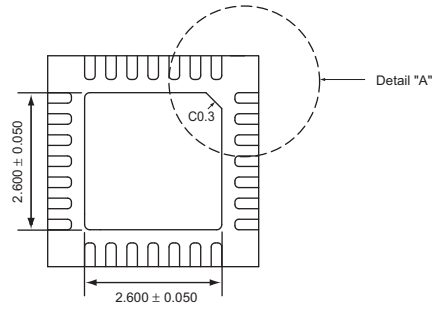

Bottom View

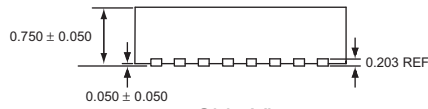

Side View

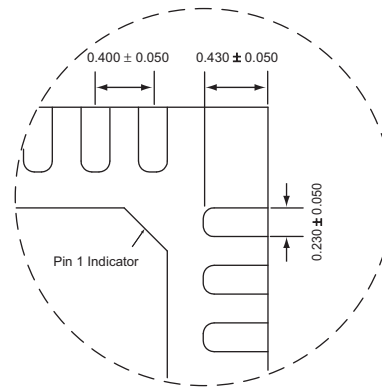

Detail "A"

All dimensions in millimeters.

1. The leadless package family, which includes QFN, TQFN, DFN, TDFN and STD FN, has exposed copper (unplated) at the end of the lead terminals due to the manufacturing process. A solder fillet at the exposed copper edge cannot be guaranteed and is not required to ensure a proper bottom solder connection.

TQFN44-28-0.45

N.B.: Not recommended for new designs.

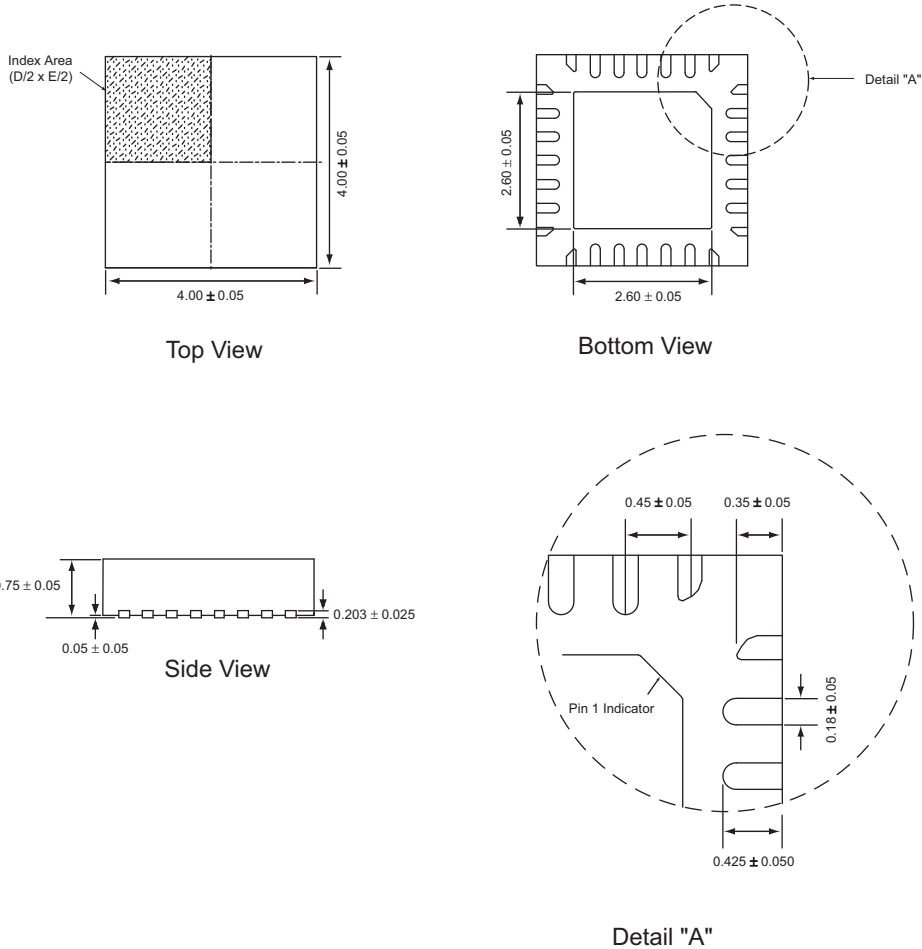

All dimensions in millimeters.

Advanced Analogic Technologies, Inc.
 3230 Scott Boulevard, Santa Clara, CA 95054
 Phone (408) 737-4600
 Fax (408) 737-4611

© Advanced Analogic Technologies, Inc. AnalogicTech cannot assume responsibility for use of any circuitry other than circuitry entirely embodied in an AnalogicTech product. No circuit patent licenses, copyrights, mask work rights, or other intellectual property rights are implied. AnalogicTech reserves the right to make changes to their products or specifications or to discontinue any product or service without notice. Except as provided in AnalogicTech's terms and conditions of sale, AnalogicTech assumes no liability whatsoever, and AnalogicTech disclaims any express or implied warranty relating to the sale and/or use of AnalogicTech products including liability or warranties relating to fitness for a particular purpose, merchantability, or infringement of any patent, copyright or other intellectual property right. In order to minimize risks associated with the customer's applications, adequate design and operating safeguards must be provided by the customer to minimize inherent or procedural hazards. Testing and other quality control techniques are utilized to the extent AnalogicTech deems necessary to support this warranty. Specific testing of all parameters of each device is not necessarily performed. AnalogicTech and the AnalogicTech logo are trademarks of Advanced Analogic Technologies Incorporated. All other brand and product names appearing in this document are registered trademarks or trademarks of their respective holders.