



3.3V CMOS 16-BIT BUS TRANSCEIVER WITH 3-STATE OUTPUTS AND 5 VOLT TOLERANT I/O

IDT74LVC162245A

FEATURES:

- Typical $t_{sk(o)}$ (Output Skew) < 250ps
- ESD > 2000V per MIL-STD-883, Method 3015; > 200V using machine model (C = 200pF, R = 0)
- $V_{cc} = 3.3V \pm 0.3V$, Normal Range
- $V_{cc} = 2.7V$ to $3.6V$, Extended Range
- CMOS power levels (0.4 μ W typ. static)
- All inputs, outputs, and I/O are 5V tolerant
- Available in SSOP, TSSOP, and TVSOP packages

DRIVE FEATURES:

- Balanced Output Drivers: $\pm 12mA$ (A port)
- High Output Drivers: $\pm 24mA$ (B port)

APPLICATIONS:

- 5V and 3.3V mixed voltage systems
- Data communication and telecommunication systems

DESCRIPTION:

This 16-bit transceiver is built using advanced dual metal CMOS technology. The LVC162245A is designed for asynchronous communication between data buses. The control-function implementation minimizes external timing requirements. This device can be used as two 8-bit transceivers or one 16-bit transceiver. It allows data transmission from the A bus to the B bus or from the B bus to the A bus, depending on the logic level at the direction-control (DIR) input. The output-enable (\overline{OE}) input can be used to disable the device so that the buses are effectively isolated. To ensure the high-impedance state during power up or power down, \overline{OE} should be tied to V_{cc} through a pullup resistor; the minimum value of the resistor is determined by the current-sinking capability of the driver.

All pins can be driven from either 3.3V or 5V devices. This feature allows the use of this device as a translator in a mixed 3.3V/5V supply system.

The LVC162245A has series resistors in the device output structure of the "A" port which will significantly reduce line noise when used with light loads. The driver has been designed to drive $\pm 12mA$ at the designated threshold levels. The "B" port has a $\pm 24mA$ driver.

FUNCTIONAL BLOCK DIAGRAM

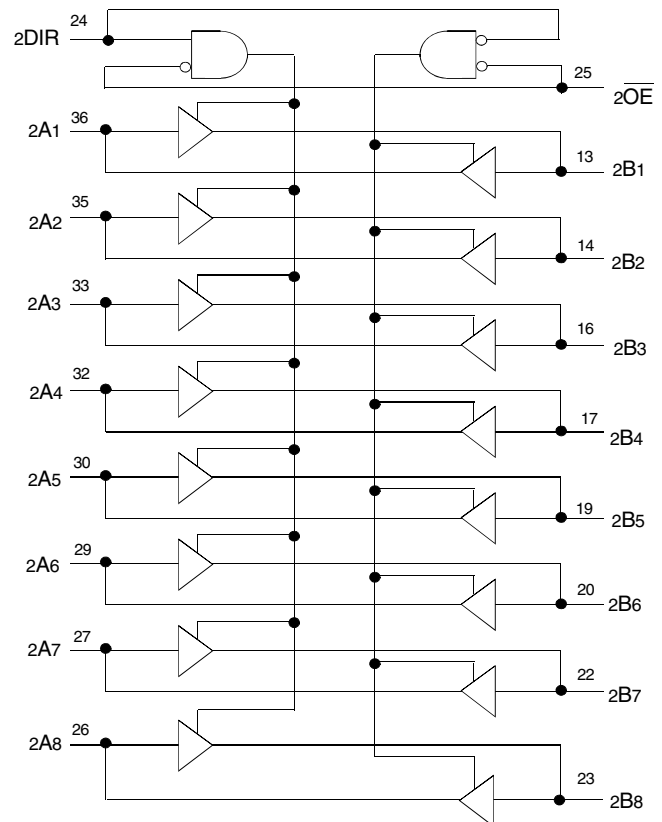
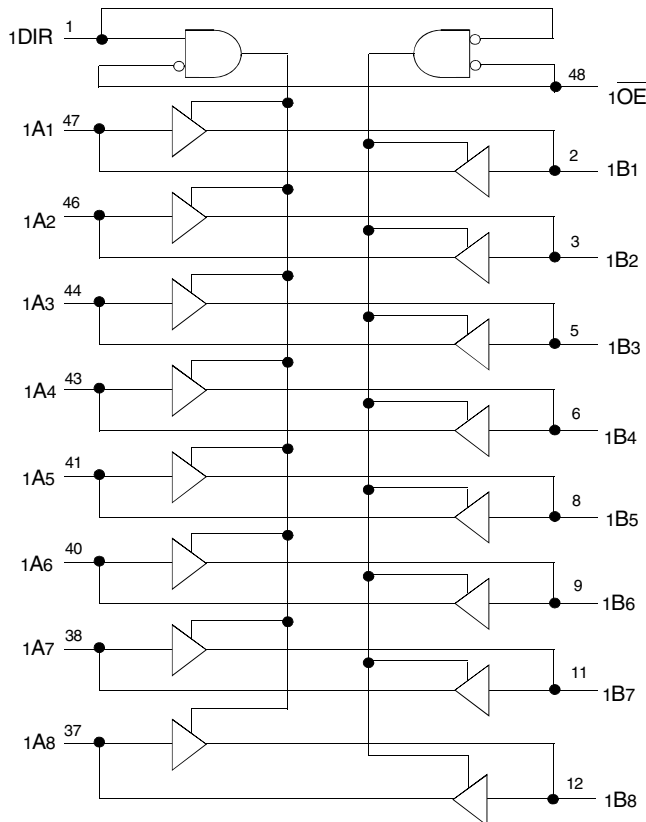

The IDT logo is a registered trademark of Integrated Device Technology, Inc.

INDUSTRIAL TEMPERATURE RANGE

AUGUST 1999

PIN CONFIGURATION

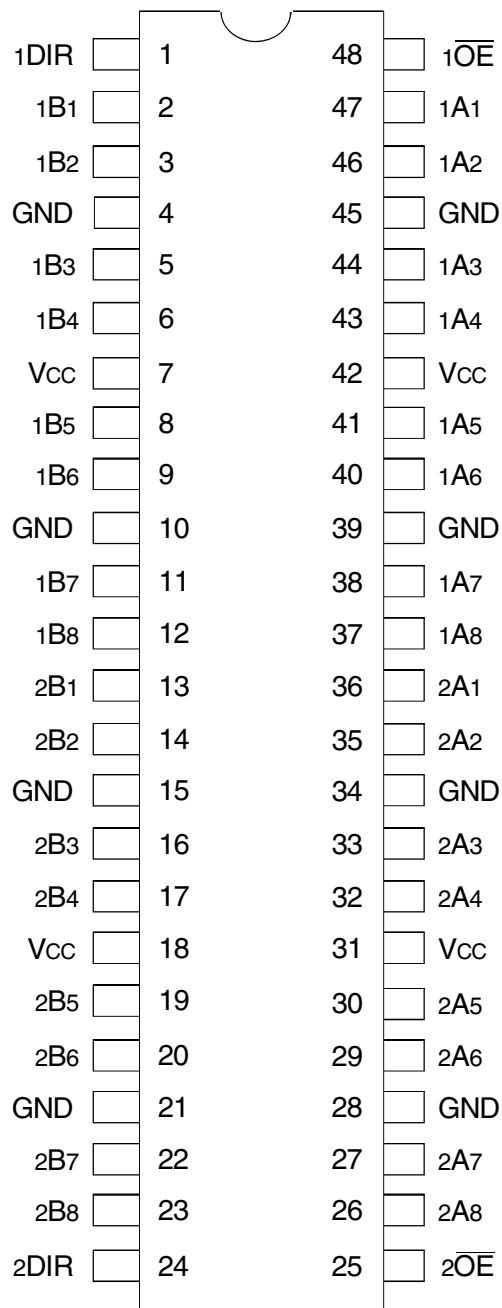

SSOP/ TSSOP/ TVSOP
TOP VIEW

ABSOLUTE MAXIMUM RATINGS⁽¹⁾

Symbol	Description	Max	Unit
V _{TERM} ⁽²⁾	Terminal Voltage with Respect to GND	-0.5 to +6.5	V
V _{TERM} ⁽³⁾	Terminal Voltage with Respect to GND	-0.5 to +6.5	V
T _{STG}	Storage Temperature	-65 to +150	°C
I _{OUT}	DC Output Current	-50 to +50	mA
I _{IK} I _{OK}	Continuous Clamp Current, V _I < 0 or V _O < 0	-50	mA
I _{CC} I _{SS}	Continuous Current through each V _{CC} or GND	±100	mA

NOTES:

- Stresses greater than those listed under ABSOLUTE MAXIMUM RATINGS may cause permanent damage to the device. This is a stress rating only and functional operation of the device at these or any other conditions above those indicated in the operational sections of this specification is not implied. Exposure to absolute maximum rating conditions for extended periods may affect reliability.
- V_{CC} terminals.
- All terminals except V_{CC}.

CAPACITANCE (T_A = +25°C, F = 1.0MHz)

Symbol	Parameter ⁽¹⁾	Conditions	Typ.	Max.	Unit
C _{IN}	Input Capacitance	V _{IN} = 0V	4.5	6	pF
C _{OUT}	Output Capacitance	V _{OUT} = 0V	6.5	8	pF
C _{I/O}	I/O Port Capacitance	V _{IN} = 0V	6.5	8	pF

NOTE:

- As applicable to the device type.

PIN DESCRIPTION

Pin Names	Description
x \overline{OE}	Output Enable Input (Active LOW)
xDIR	Direction Control Output
xAx	Side A Inputs or 3-State Outputs
xBx	Side B Inputs or 3-State Outputs

FUNCTION TABLE (EACH 8-BIT SECTION)⁽¹⁾

Inputs		Outputs
x \overline{OE}	xDIR	
L	L	B Data to A Bus
L	H	A Data to B Bus
H	X	Isolation

NOTE:

- H = HIGH Voltage Level
X = Don't Care
L = LOW Voltage Level

DC ELECTRICAL CHARACTERISTICS OVER OPERATING RANGE

Following Conditions Apply Unless Otherwise Specified:

Operating Condition: $T_A = -40^{\circ}\text{C}$ to $+85^{\circ}\text{C}$

Symbol	Parameter	Test Conditions		Min.	Typ. ⁽¹⁾	Max.	Unit
V_{IH}	Input HIGH Voltage Level	$V_{CC} = 2.3\text{V}$ to 2.7V		1.7	—	—	V
		$V_{CC} = 2.7\text{V}$ to 3.6V		2	—	—	
V_{IL}	Input LOW Voltage Level	$V_{CC} = 2.3\text{V}$ to 2.7V		—	—	0.7	V
		$V_{CC} = 2.7\text{V}$ to 3.6V		—	—	0.8	
I_{IH} I_{IL}	Input Leakage Current	$V_{CC} = 3.6\text{V}$	$V_I = 0$ to 5.5V	—	—	± 5	μA
I_{OZH} I_{OZL}	High Impedance Output Current (3-State Output pins)	$V_{CC} = 3.6\text{V}$	$V_O = 0$ to 5.5V	—	—	± 10	μA
I_{OFF}	Input/Output Power Off Leakage	$V_{CC} = 0\text{V}$, V_{IN} or $V_O \leq 5.5\text{V}$		—	—	± 50	μA
V_{IK}	Clamp Diode Voltage	$V_{CC} = 2.3\text{V}$, $I_{IN} = -18\text{mA}$		—	-0.7	-1.2	V
V_H	Input Hysteresis	$V_{CC} = 3.3\text{V}$		—	100	—	mV
I_{CCL} I_{CCH} I_{CCZ}	Quiescent Power Supply Current	$V_{CC} = 3.6\text{V}$	$V_{IN} = \text{GND}$ or V_{CC}	—	—	10	μA
			$3.6 \leq V_{IN} \leq 5.5\text{V}^{(2)}$	—	—	10	
ΔI_{CC}	Quiescent Power Supply Current Variation	One input at $V_{CC} - 0.6\text{V}$, other inputs at V_{CC} or GND		—	—	500	μA

NOTES:

1. Typical values are at $V_{CC} = 3.3\text{V}$, $+25^{\circ}\text{C}$ ambient.
2. This applies in the disabled state only.

OUTPUT DRIVE CHARACTERISTICS (A PORT)

Symbol	Parameter	Test Conditions ⁽¹⁾		Min.	Max.	Unit
V_{OH}	Output HIGH Voltage	$V_{CC} = 2.3\text{V}$ to 3.6V	$I_{OH} = -0.1\text{mA}$	$V_{CC} - 0.2$	—	V
			$V_{CC} = 2.3\text{V}$	$I_{OH} = -4\text{mA}$	1.9	
		$V_{CC} = 2.7\text{V}$	$I_{OH} = -6\text{mA}$	1.7	—	
			$I_{OH} = -4\text{mA}$	2.2	—	
		$V_{CC} = 3\text{V}$	$I_{OH} = -8\text{mA}$	2	—	
			$I_{OH} = -6\text{mA}$	2.4	—	
V_{OL}	Output LOW Voltage	$V_{CC} = 2.3\text{V}$ to 3.6V	$I_{OL} = 0.1\text{mA}$	—	0.2	V
			$V_{CC} = 2.3\text{V}$	$I_{OL} = 4\text{mA}$	—	
		$V_{CC} = 2.7\text{V}$	$I_{OL} = 6\text{mA}$	—	0.55	
			$I_{OL} = 4\text{mA}$	—	0.4	
		$V_{CC} = 3\text{V}$	$I_{OL} = 8\text{mA}$	—	0.6	
			$I_{OL} = 6\text{mA}$	—	0.55	
		$I_{OL} = 12\text{mA}$	—	0.8		

NOTE:

1. V_{IH} and V_{IL} must be within the min. or max. range shown in the DC ELECTRICAL CHARACTERISTICS OVER OPERATING RANGE table for the appropriate V_{CC} range. $T_A = -40^{\circ}\text{C}$ to $+85^{\circ}\text{C}$.

OUTPUT DRIVE CHARACTERISTICS (B PORT)

Symbol	Parameter	Test Conditions ⁽¹⁾		Min.	Max.	Unit
VOH	Output HIGH Voltage	VCC = 2.3V to 3.6V	IOH = - 0.1mA	VCC - 0.2	—	V
		VCC = 2.3V	IOH = - 6mA	2	—	
		VCC = 2.3V	IOH = - 12mA	1.7	—	
		VCC = 2.7V		2.2	—	
		VCC = 3V		2.4	—	
		VCC = 3V	IOH = - 24mA	2	—	
VOL	Output LOW Voltage	VCC = 2.3V to 3.6V	IOL = 0.1mA	—	0.2	V
		VCC = 2.3V	IOL = 6mA	—	0.4	
			IOL = 12mA	—	0.7	
		VCC = 2.7V	IOL = 12mA	—	0.4	
		VCC = 3V	IOL = 24mA	—	0.55	

NOTE:
1. VIH and VIL must be within the min. or max. range shown in the DC ELECTRICAL CHARACTERISTICS OVER OPERATING RANGE table for the appropriate VCC range. TA = - 40°C to + 85°C.

OPERATING CHARACTERISTICS, VCC = 3.3V ± 0.3V, TA = 25°C

Symbol	Parameter	Test Conditions	Typical	Unit
CPD	Power Dissipation Capacitance per Transceiver Outputs enabled	CL = 0pF, f = 10Mhz		pF
CPD	Power Dissipation Capacitance per Transceiver Outputs disabled			

SWITCHING CHARACTERISTICS (A PORT)⁽¹⁾

Symbol	Parameter	VCC = 2.7V		VCC = 3.3V ± 0.3V		Unit
		Min.	Max.	Min.	Max.	
tPLH tPHL	Propagation Delay xBx to xAx	1.5	5.7	1.5	4.8	ns
tPZH tPZL	Output Enable Time xOE to xAx	1.5	7.9	1.5	6.3	ns
tPHZ tPLZ	Output Disable Time xOE to xAx	1.5	8.3	2.2	7.4	ns
tsk(o)	Output Skew ⁽²⁾	—	—	—	500	ps

NOTES:
1. See TEST CIRCUITS AND WAVEFORMS. TA = - 40°C to + 85°C.
2. Skew between any two outputs of the same package and switching in the same direction.

SWITCHING CHARACTERISTICS (B PORT)⁽¹⁾

Symbol	Parameter	VCC = 2.7V		VCC = 3.3V ± 0.3V		Unit
		Min.	Max.	Min.	Max.	
tPLH tPHL	Propagation Delay xAx to xBx	1.5	4.7	1	4	ns
tPZH tPZL	Output Enable Time xOE to xBx	1.5	6.7	1.5	5.5	ns
tPHZ tPLZ	Output Disable Time xOE to xBx	1.5	7.1	1.5	6.6	ns
tsk(o)	Output Skew ⁽²⁾	—	—	—	500	ps

NOTES:
1. See TEST CIRCUITS AND WAVEFORMS. TA = - 40°C to + 85°C.
2. Skew between any two outputs of the same package and switching in the same direction.

TEST CIRCUITS AND WAVEFORMS

TEST CONDITIONS

Symbol	V _{CC} ⁽¹⁾ = 3.3V±0.3V	V _{CC} ⁽¹⁾ = 2.7V	V _{CC} ⁽²⁾ = 2.5V±0.2V	Unit
V _{LOAD}	6	6	2 x V _{CC}	V
V _{IH}	2.7	2.7	V _{CC}	V
V _T	1.5	1.5	V _{CC} / 2	V
V _{LZ}	300	300	150	mV
V _{HZ}	300	300	150	mV
C _L	50	50	30	pF

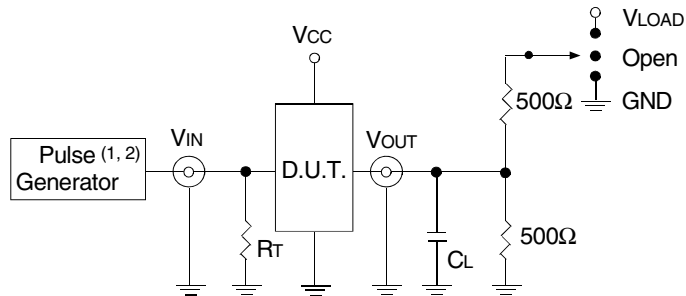

Test Circuit for All Outputs

DEFINITIONS:

C_L = Load capacitance: includes jig and probe capacitance.
R_T = Termination resistance: should be equal to Z_{OUT} of the Pulse Generator.

NOTES:

1. Pulse Generator for All Pulses: Rate ≤ 10MHz; t_r ≤ 2.5ns; t_r ≤ 2.5ns.
2. Pulse Generator for All Pulses: Rate ≤ 10MHz; t_r ≤ 2ns; t_r ≤ 2ns.

SWITCH POSITION

Test	Switch
Open Drain Disable Low Enable Low	V _{LOAD}
Disable High Enable High	GND
All Other Tests	Open

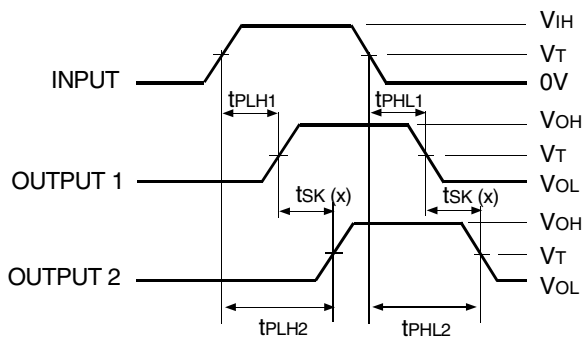

$$tsk(x) = |t_{PLH2} - t_{PLH1}| \text{ or } |t_{PHL2} - t_{PHL1}|$$

Output Skew - tsk(x)

NOTES:

1. For tsk(o) OUTPUT1 and OUTPUT2 are any two outputs.
2. For tsk(b) OUTPUT1 and OUTPUT2 are in the same bank.

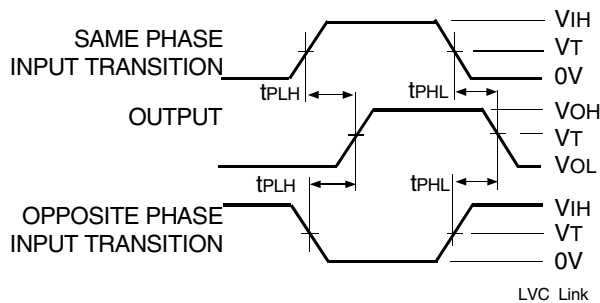

Propagation Delay

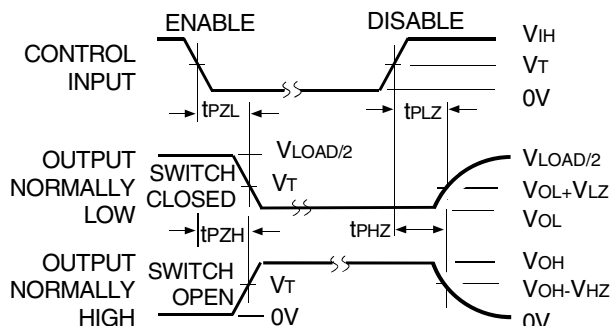

Enable and Disable Times

NOTE:

1. Diagram shown for input Control Enable-LOW and input Control Disable-HIGH.

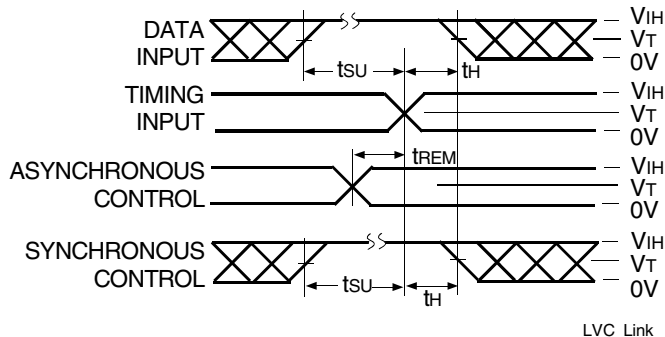

Set-up, Hold, and Release Times

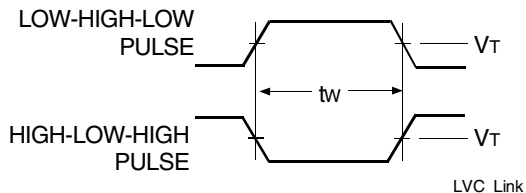

Pulse Width

ORDERING INFORMATION

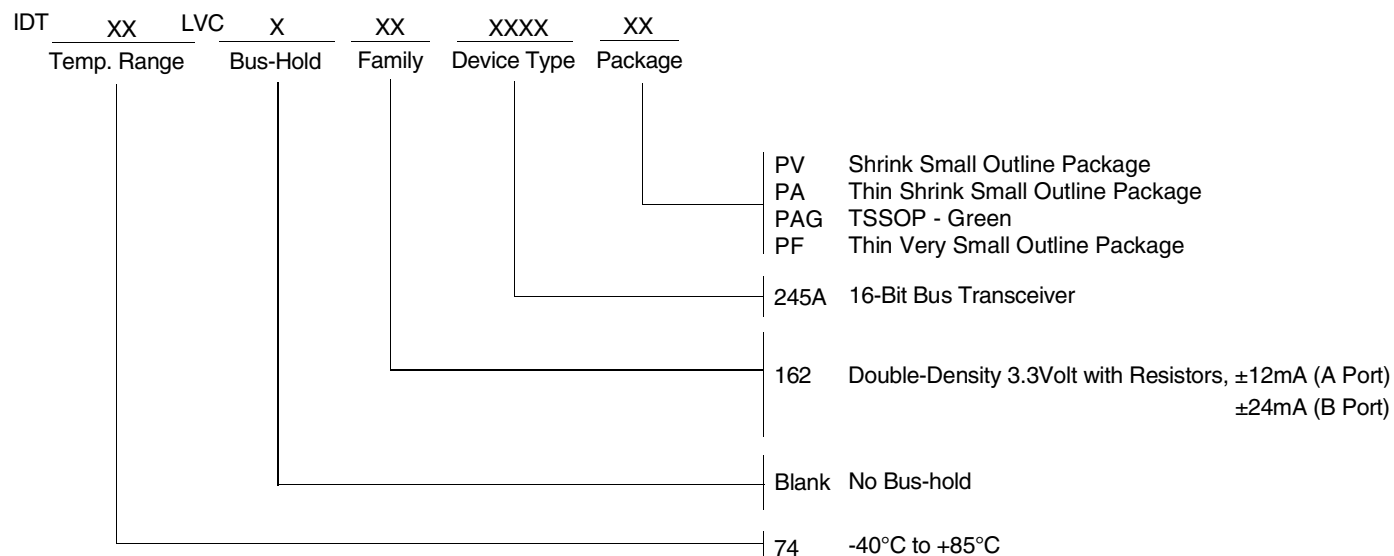

CORPORATE HEADQUARTERS
 6024 Silver Creek Valley Road
 San Jose, CA 95138

for SALES:
 800-345-7015 or 408-284-8200
 fax: 408-284-2775
 www.idt.com

for Tech Support:
 logichelp@idt.com