

Frequency Foldback Current Mode PWM Controller

PRELIMINARY
FEATURES

- Frequency Foldback Reduces Operating Frequency Under Fault Conditions
- Accurate Programmable Volt-Second Clamp
- Programmable Maximum Duty Cycle Clamp
- Oscillator Synchronization
- Overcurrent Protection
- Shutdown with Full Soft Start
- Wide Gain Bandwidth Amplifier (GBW > 2.5MHz)
- Current Mode Operation
- Precision 5V Reference

DESCRIPTION

The UCC3884 is a high performance current mode PWM controller intended for single ended switch mode power supplies. The chip implements a frequency foldback scheme that decreases the oscillator frequency as the output voltage falls below a programmed value. This technique decreases the average output current sourced into a low impedance load which can occur during an output short circuit or overload condition. Excessive short circuit current is more prevalent in high frequency converters where the propagation delay and switch turn-off time forces a minimum attainable duty cycle. An accurate volt-second clamp limits the duty cycle during line or load transient conditions which could otherwise saturate the transformer. The volt-second clamp may also be used with an external overvoltage protection circuit to handle fault conditions such as current sense disconnect or current transformer saturation. The frequency foldback, volt-second clamp, cycle-by-cycle current limit, and overcurrent shutdown provide a rich set of protection features for use in peak current mode pulse width modulators.

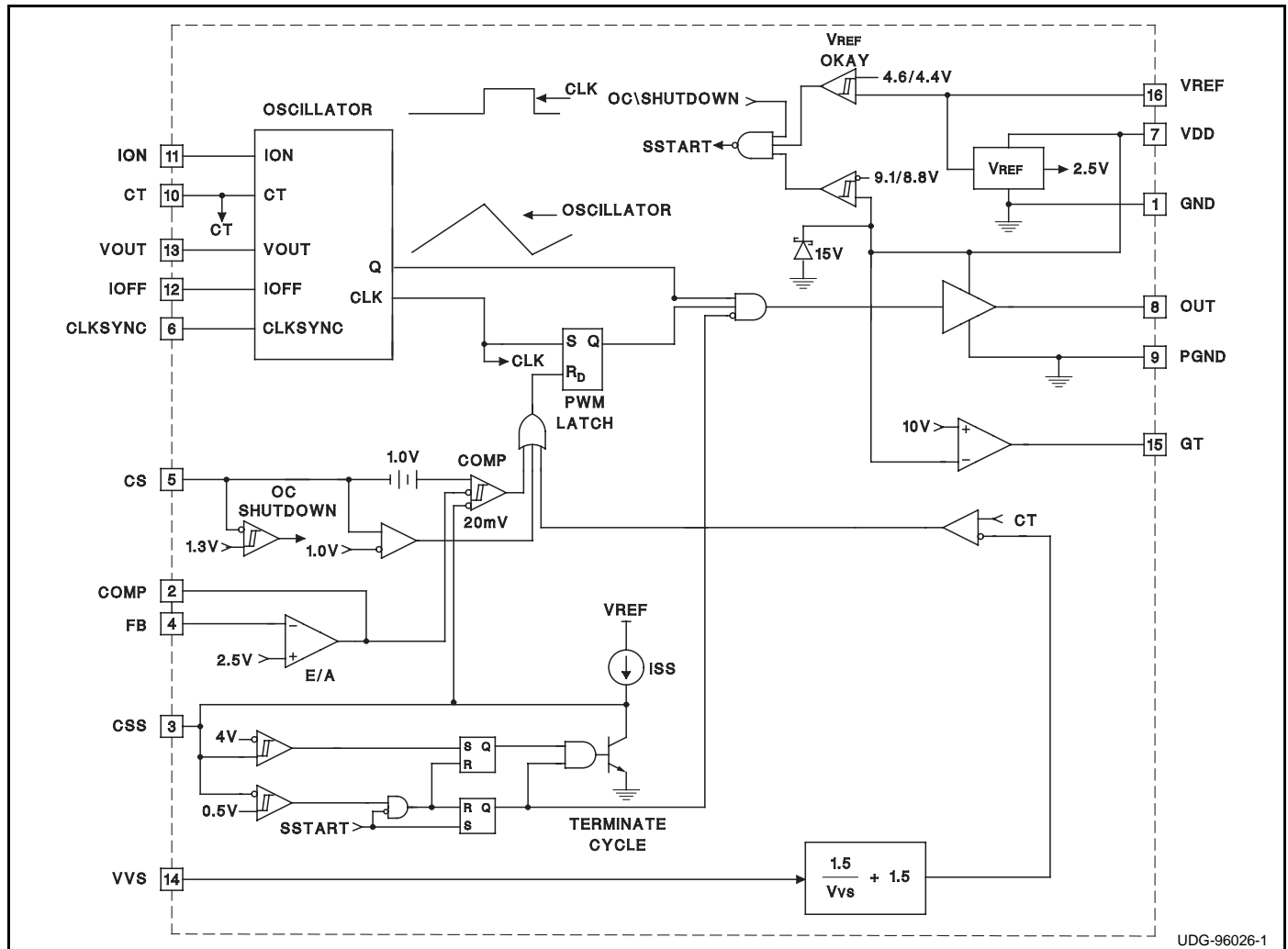
BLOCK DIAGRAM

UDG-96026-1

ABSOLUTE MAXIMUM RATINGS

Supply Voltage	15V
Output Sink Current	1A
Output Source Current	0.5A
All Other Pins	6V
Storage Temperature	-65°C to +150°C
Junction Temperature	-55°C to +150°C
Lead Temperature (Soldering, 10 sec.)	+300°C

Currents are positive into, negative out of the specified terminal. Consult Packaging Section of Databook for thermal limitations and considerations of packages.

CONNECTION DIAGRAMS

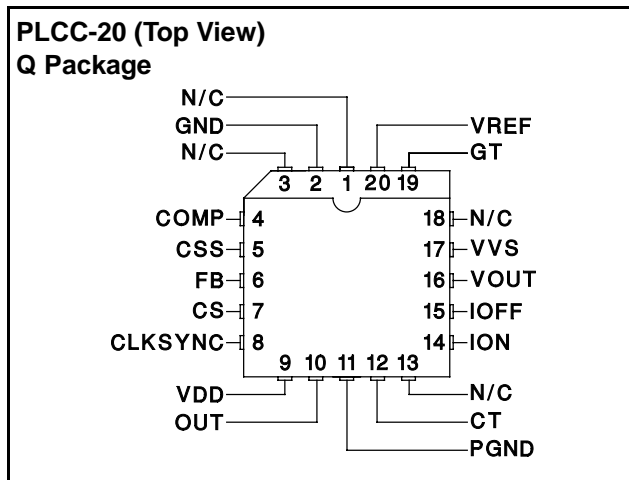
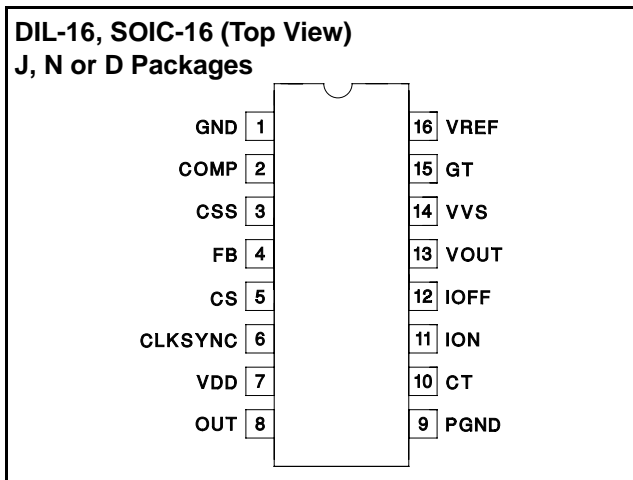

ELECTRICAL CHARACTERISTICS: Unless otherwise specified, these specifications apply for $T_A = -55^\circ\text{C}$ to 125°C for UCC1884, -40°C to 85°C for the UCC2884, and 0°C to 70°C for the UCC3884, $CT = 150\text{pF}$, $R_{ON} = 53\text{k}$, $R_{OFF} = 38\text{k}$, $V_{OUT} = V_{REF}$, $V_{VS} = 0\text{V}$, $CSS = 2.5\text{nF}$, $V_{DD} = 11\text{V}$, Output no load, $T_A = T_J$.

PARAMETER	TEST CONDITIONS	MIN	TYP	MAX	UNITS
5V Reference Section					
VREF	$I_{REF} = 0\text{mA}$	4.86	5	5.14	V
Line Regulation	$V_{DD} = 10\text{V}$ to 12V		1	10	mV
Load Regulation	$0 < I_{REF} < 5\text{mA}$		1	10	mV
Short Circuit I	$V_{REF} = 0\text{V}$		15	45	mA
Oscillator Section					
Accuracy	$V_{OUT} = V_{REF}$	450	500	550	kHz
Foldback Frequency	$V_{OUT} = 0.65\text{V}$	250	300	350	kHz
CLKSYNC Output High		4.8	5	5.2	V
CLKSYNC Output Low			0.2	0.8	V
CLKSYNC Sink Current	$CLKSYNC = 1\text{V}$	1.2	2.2		mA
CLKSYNC Source Current	$CLKSYNC = 3\text{V}$		-0.2	-0.1	mA
CLKSYNC Input Threshold	$CLKSYNC$ from 5V to 0V (Edge Detect)		3.5		V
Error Amplifier Section					
I_B	Total Bias Current; Regulating Level	-1		1	μA
FB Voltage	$FB = COMP$	2.43	2.5	2.57	V
A_{VO}		60	90		dB
GBW	$F = 100\text{kHz}$ (Note 1)	2.5	5		MHz
Output Source Current	$FB = 2.3\text{V}$, $COMP = 2.5\text{V}$	-1.0	-2.8		mA
Output Sink Current	$FB = 2.7\text{V}$, $V_{COMP} = 1\text{V}$	0.250	1.5		mA

ELECTRICAL CHARACTERISTICS (cont.): Unless otherwise specified, these specifications apply for $T_A = -55^\circ\text{C}$ to 125°C for UCC1884, -40°C to 85°C for the UCC2884, and 0°C to 70°C for the UCC3884, $C_T = 150\text{pF}$, $R_{ON} = 53\text{k}$, $R_{OFF} = 38\text{k}$, $V_{OUT} = V_{REF}$, $V_{VS} = 0\text{V}$, $C_{SS} = 2.5\text{nF}$, $V_{DD} = 11\text{V}$, Output no load, $T_A = T_J$.

PARAMETER	TEST CONDITIONS	MIN	TYP	MAX	UNITS
Error Amplifier Section (cont.)					
V_{OL}	$I_O = 100\mu\text{A}$		0.3	0.8	V
V_{OH}	$I_O = -100\mu\text{A}$	2.7	3.1	3.5	V
PWM Section					
Minimum Duty Cycle	$FB = 3\text{V}$, $CS = 0\text{V}$			0	%
Maximum Duty Cycle	$FB = 0\text{V}$, $CS = 0\text{V}$	77	80	83	%
Current Sense Section					
Input Bias Current (CS)				2	μA
CS Shutdown Threshold		1.235	1.3	1.365	V
CS Shutdown Hysteresis			20		mV
CS Over Current Threshold		0.95	1	1.05	V
Current/Fault Section					
Soft Start Charge Current		-10	-20	-30	μA
Soft Start Discharge Current		10	20	30	μA
V_{OL}			0	50	mV
Soft Start Complete Threshold		3.6	4	4.4	V
Soft Start Restart Threshold		0.4	0.5	0.6	V
Volt Second Clamp					
Duty Cycle	$V_{VS} = 1.4\text{V}$, $T_A = -55^\circ\text{C}$ to 125°C	57.6	64	70.4	%
	$V_{VS} = 1.4\text{V}$, $T_A = -40^\circ\text{C}$ to 85°C	60.8	64	67.2	%
	$V_{VS} = 1.4\text{V}$, $T_A = 0^\circ\text{C}$ to 70°C	62.08	64	65.92	%
	$V_{VS} = 3.7\text{V}$, $T_A = -55^\circ\text{C}$ to 125°C	21.6	24	26.4	%
	$V_{VS} = 3.7\text{V}$, $T_A = -40^\circ\text{C}$ to 85°C	22.8	24	25.2	%
	$V_{VS} = 3.7\text{V}$, $T_A = 0^\circ\text{C}$ to 70°C	23.28	24	24.72	%
I_B	$V_{VS} = 3.7\text{V}$	-1		+1	μA
Output Stage					
Output Low Saturation	$I_{OUT} = 100\text{mA}$		0.5	0.9	V
Output High Saturation	$I_{OUT} = -50\text{mA}$		0.5	0.9	V
	$I_{OUT} = -200\text{mA}$			1.9	V
UVLO Output Low Saturation	$I_{OUT} = 20\text{mA}$, $V_{DD} = 0\text{V}$		0.7	1.2	V
Rise Time	$C_L = 1\text{nF}$		50	70	ns
Fall Time	$C_L = 1\text{nF}$		30	50	ns
Undervoltage Lockout					
Turn-On Threshold Voltage		8.4	8.9	9.4	V
Hysteresis		200	600		mV
Startup Regulator					
Regulated VDD Voltage		9.5	10	10.5	V
VDD Override Threshold				10.7	V
Overall					
I_{DD} (run)	$f = 500\text{kHz}$	2	5	10	mA
I_{DD} Startup Current	$V_{DD} = 5.4\text{V}$			200	μA
VDD Clamp	$I_{DD} = 10\text{mA}$	12	13.5	15	V

Note 1: Guaranteed by design. Not 100% tested in production.

PIN DESCRIPTIONS

CLKSYNC: An edge triggered active low TTL signal to this pin synchronizes the oscillator to an external clock. When VOUT decreases below 3.0V, the frequency fold-back circuit is activated and the controller becomes unsynchronized. When VOUT exceeds 3.0V, the controller resynchronizes to the external clock.

COMP: The output of the voltage error amplifier used for compensation. The output is clamped to 3.0V minimum.

CS: Current sense input. This pin accepts a voltage proportional to converter inductor current. The voltage at CS is compared to the output of the compensated error amplifier to control the on-time of the switch. Voltage mode control can be realized by driving this pin with a fixed sawtooth ramp. Voltage feedforward is achieved by making the peak of this ramp proportional to the input voltage.

CSS: A capacitor, C_{SS}, to ground programs the soft start time for the power up sequence. This function is also used when an overcurrent fault occurs. As CSS is charged, the PWM comparator uses the lowest of either the voltage at CSS or the error amplifier output voltage to determine the duty cycle. The duty cycle, therefore, slowly increases during the soft start cycle. The faults that cause CSS to discharge and shutdown the controller are the logical OR of VREF below 4.4V or VDD below 8.8V. If a fault is still present when CSS is discharged below 0.5V, the supply remains off until the fault is cleared. The soft start time is determined by:

$$T_{SS} = 3.5 \cdot \frac{C_{SS}}{I_{SS}}$$

where I_{SS} is 20μA. A current limit terminates the present cycle. It does not generate a soft start cycle.

CT: A capacitor, C_T to ground, is charged and discharged creating the oscillator waveform. This waveform varies between 1.5V and 3.5V. The operating frequency is determined by

$$f = \frac{4.4}{C_T \cdot \left(\frac{R_{ON}}{1.5} + \frac{R_{OFF}}{3.5} \right)}$$

The ratio of the time duration of the positive sloped portion of the C_T voltage waveform to the period gives the maximum duty cycle.

FB: The inverting input of the voltage amplifier used to sense the output voltage. The non-inverting input of the error amplifier is internally connected to 2.5V.

GND: The ground pin internally used for all the amplifiers and as the return for all resistor and capacitor connections to the UCC3884.

GT: Used to drive an external depletion-mode MOSFET for the housekeeping power supply. The MOSFET is turned off when the bootstrap winding voltage exceeds 10V. There is 300mV of hysteresis around the 10V turn-off voltage to prevent oscillation. See Typical Application.

IOFF: A resistor, R_{OFF}, to ground, programs the discharge current of the timing capacitor C_T. This is a variable discharge current which determines the negative slope of the oscillator voltage waveform at C_T. The discharge time is dependent on the voltage at the VOUT pin. The discharge current is given by I_{OFF} = VOUT/R_{OFF}. The VOUT pin is internally clamped to 3.5V maximum.

ION: A resistor, R_{ON}, to ground programs the charge current of the timing capacitor, C_T, which generates the positive slope of the oscillator waveform. The charge time is constant and corresponds to the maximum output on-time at OUT. The charge current equation is I_{ON} = 1.5V/R_{ON}. When required the linear positive slope of the C_T voltage could be buffered and used to provide slope compensation into the CS pin.

OUT: The output of the controller. The peak source current is 0.5A and the peak sink current is 1.0A. The faults listed under the CSS description turn off this output.

PGND: The power ground pin is used as the return for the output transistor drive stage.

VDD: The input voltage of the chip. A low ESR and ESL ceramic capacitor from this pin to GND should be used to bypass internal switching transients.

VOUT: This pin accomplishes frequency foldback by controlling the discharge current for the oscillator C_T capacitor. A dc voltage proportional to the output voltage is connected to this pin. To startup with zero output voltage the user should tie a resistor between VREF and VOUT. The value depends on the lowest desired operating frequency. When VOUT decreases below 3.5V the frequency decreases by reducing the discharge current I_{OFF}. When VOUT increases, the frequency increases by increasing the discharge current. The maximum operating frequency occurs when VOUT = 3.5V. The C_T charge time is constant to guarantee a maximum output duty cycle. This pin must be above 3.0V to allow synchronization to occur.

PIN DESCRIPTIONS (cont.)

VREF: This pin is the output of the 5V regulated reference. Bypass this pin with a low ESR and ESL ceramic capacitor (e.g., 0.47 μ F).

VVS: Provides a programmable duty cycle clamp which is dependent upon the input voltage. A resistor divider network reduces the input voltage supplied to VVS. The

IC determines the reciprocal of the voltage at VVS and scales the result. The voltage is then compared to the oscillator waveform to clamp the duty cycle. The purpose of this clamp is to reduce the likelihood of saturating the isolation transformer during unusual line or load conditions.

APPLICATION INFORMATION

Theory of Operation: The UCC3884 current mode PWM controller contains a programmable oscillator which includes the ability to synchronize multiple PWMs. The positive and negative sloped portions of the oscillator waveform (measured at CT), have time intervals that are set by external resistors at ION and IOFF. The operating frequency is inversely proportional to the timing capacitor. The negative sloped portion of the oscillator waveform is extended in time as the measured output voltage decreases providing protection during output faults. The power supply output voltage and the voltage from VREF are fed back to VOUT. When the output voltage decreases, the voltage at VOUT also decreases. As VOUT decreases below 3.5V, the operating frequency decreases. This reduction in frequency allows the duty cycle to decrease below what the CS to OUT delay would otherwise permit. This is referred to as frequency foldback. An output short circuit or overload causes the converter to enter the frequency foldback mode. Synchronization to other controllers can only occur during normal operation, that is, when VOUT is greater than 3.0V.

GT is provided to turn off an external depletion-mode MOSFET after startup when the bootstrap winding exceeds 10V. This depletion-mode MOSFET is used in the housekeeping section of the converter to simplify startup biasing circuitry. The amplifier that drives this MOSFET has 300mV of hysteresis to avoid oscillation during power up.

An accurate programmable volt-second technique clamps the duty cycle. The duty cycle limit is inversely proportional to input voltage and a resistor divider net-

work is used to program the proportionality constant. At a given input voltage and constant load, under closed loop control, the operating duty cycle is a fixed value. The volt-second clamp duty cycle may then be set somewhat higher than this operating duty cycle. For other input voltages, the volt-second clamp will still exceed the steady state operating duty cycle. This allows normal closed loop operation of the converter. It is during a load transient (a fault such as a momentary short circuit) as the error amplifier increases the duty cycle, that when the volt-second clamp accurately limits the maximum volt-seconds. This ensures that the transformer does not saturate during a fault which can fail the power supply. After the fault is removed the converter resumes closed loop control.

CSS is provided which allows the UCC3884 to be disabled with an external transistor. The increasing pulse width at OUT during soft start should be programmed to be less than the pulse width of the duty cycle limit that the frequency foldback circuitry creates. The frequency foldback circuit will be in effect during soft start since the output voltage fed back to VOUT is less than 3.5V. Designing the circuit in this fashion allows a proper startup sequence.

The current sense feedback pin has an overcurrent protection feature which forces a soft start cycle only if the IC is not currently in a soft start cycle. A 1V bias at the PWM comparator's non-inverting input and a reset dominant PWM latch permit zero duty cycle operation.

The error amplifier has a wide gain-bandwidth product and its non-inverting input is internally set to 2.5VDC.

APPLICATION INFORMATION (cont.)

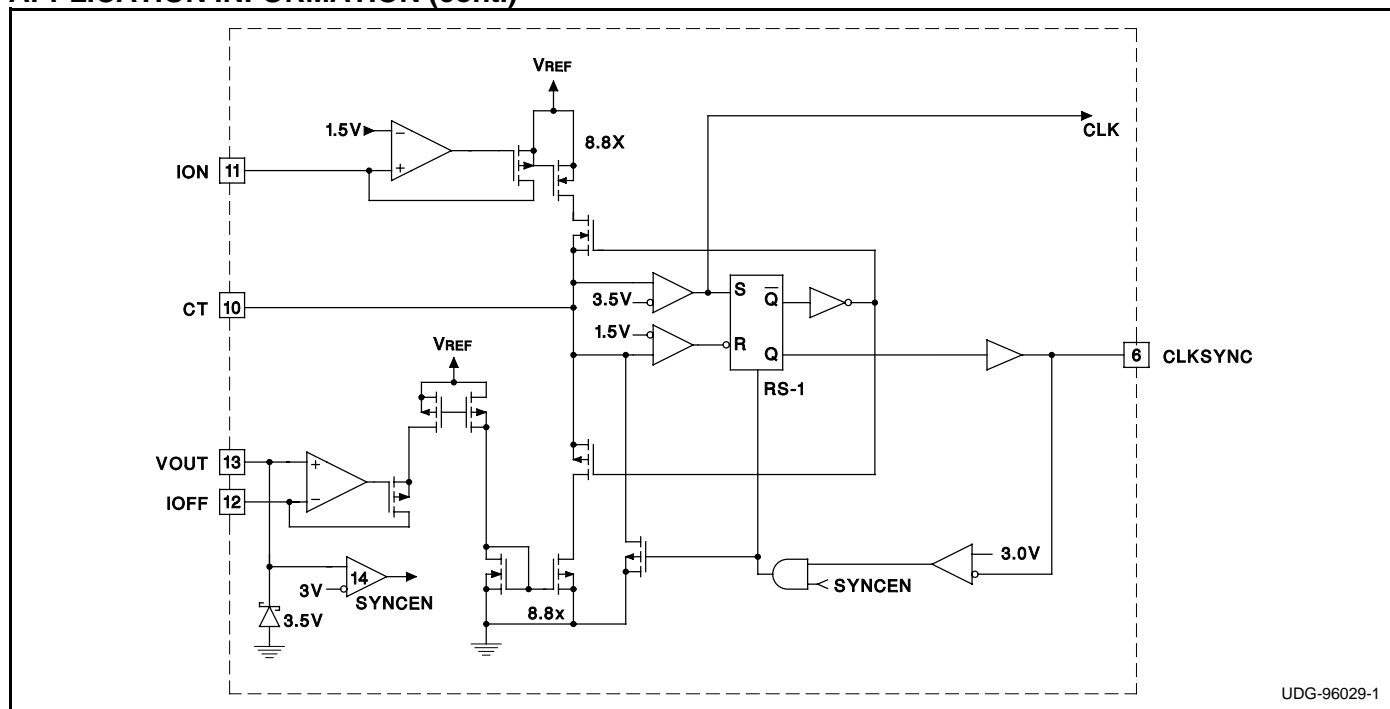

Figure 1. UCC3884 Oscillator

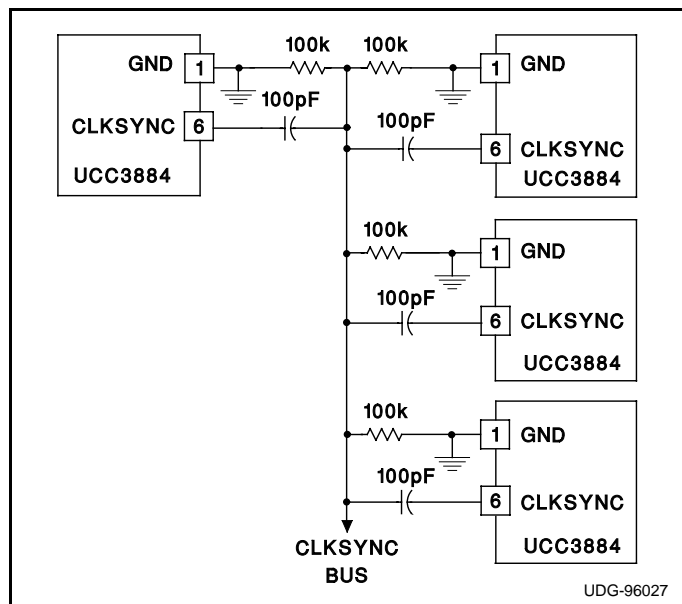

Figure 2. Oscillator Synchronization Connection Diagram

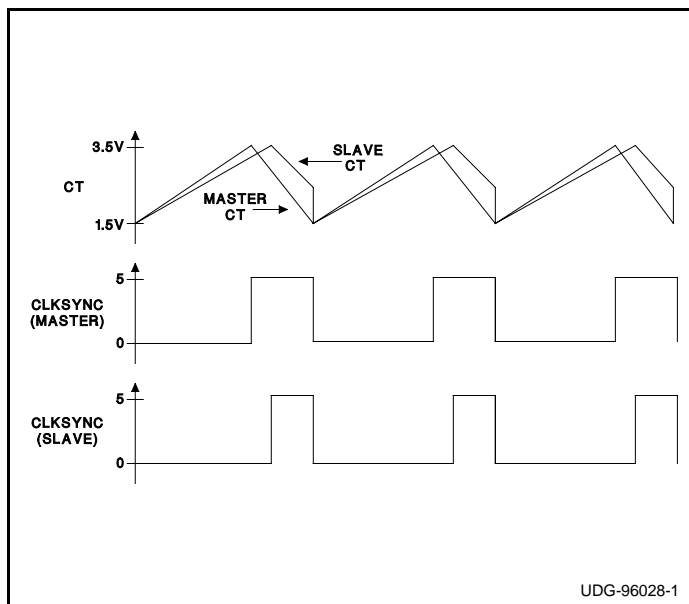

Figure 3. Oscillator Waveforms

OSCILLATOR INFORMATION

The oscillator has charge and discharge currents programmed with resistors to ground from ION and IOFF respectively, as seen on the Oscillator Block Diagram (Figure 1). This generates a linear sawtooth waveform on CT. Frequency foldback is accomplished by the level shifted output voltage controlling the VOUT voltage which decreases the discharge current and the frequency.

Synchronization is accomplished by coupling the fastest oscillator CLKSYNC signal as shown on the Oscillator Synchronization Diagram (Figure 2). The fastest (master) CLKSYNC pin will couple a negative pulse into the slower (slave) CLKSYNC pins forcing the slaves' CT pins to quickly discharge as shown on the Oscillator Waveform diagram (Figure 3).

OSCILLATOR INFORMATION (cont.)

The following explains two synchronization techniques:

1. If the user does not care which unit is the master, then the oscillator frequencies are designed as accurate as necessary and one unit will become the master and synchronize the remaining units. The user will never know exactly which unit will be the master upon power up.
2. If the user does care which unit is the master, a unit should be identified as the master, and the frequency

and maximum duty cycle clamp should be programmed accordingly. The ROFF resistor which programs the slave units oscillator discharge ramp should be between 50% and 100% of the ROFF resistor which programs the master. This guarantees that if a slave unit tries to synchronize the master, the master frequency will still be faster than the slave frequency and the master will synchronize all the remaining units.

TYPICAL APPLICATION

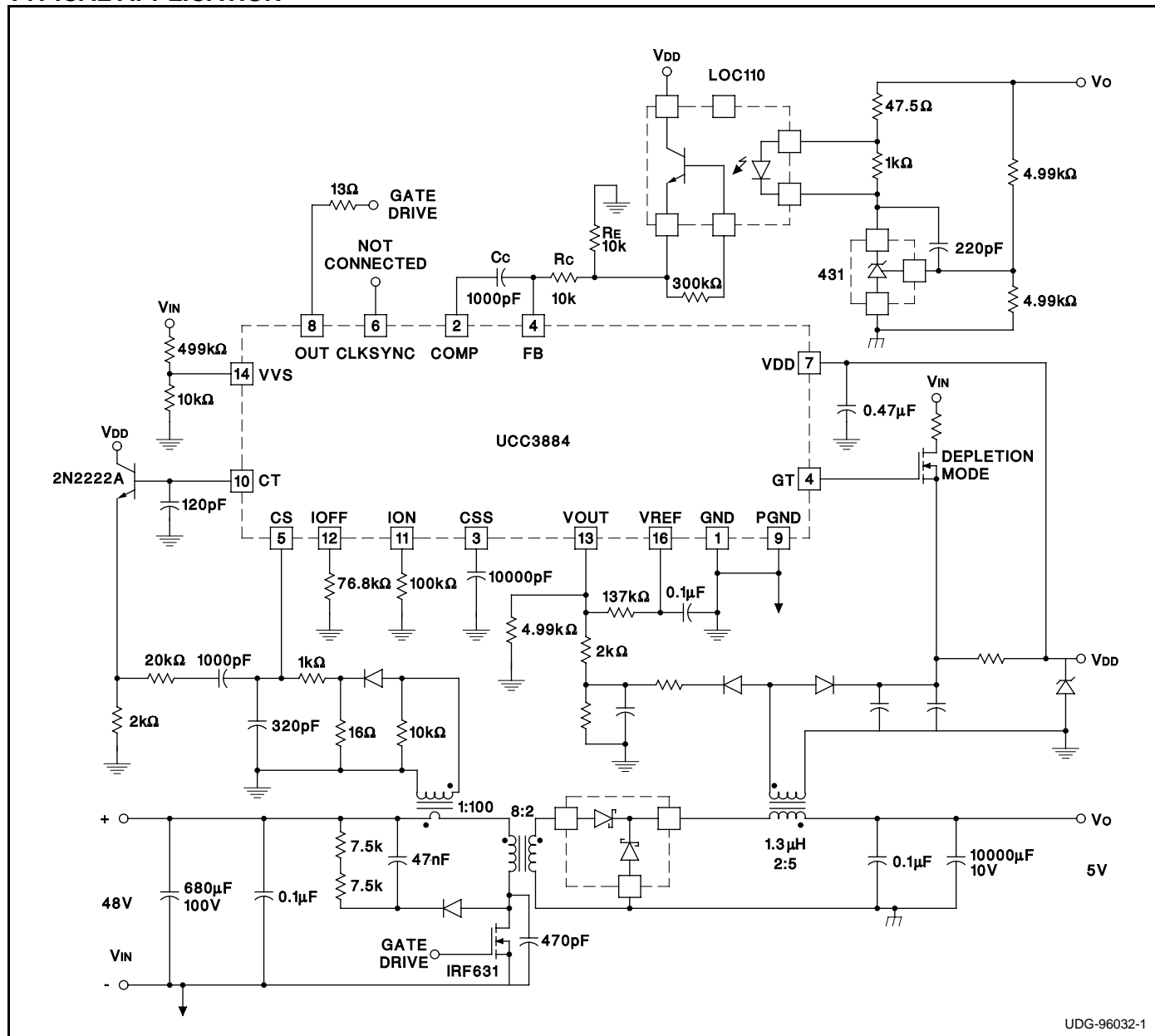

UDG-96032-1