

## CDSV3-202N-G/202P-G

Reverse Voltage: 80 Volts  
 Power Dissipation: 200 mW  
 RoHS Device

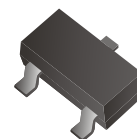

### Features

- Design for mounting on small surface.
- High speed switching.
- High mounting capability, strong surge withstand, high reliability.

### Mechanical data

- Case: SOT-323, molded plastic.
- Terminals: solderable per MIL-STD-750, method 2026.
- Approx. weight: 0.006 grams

### Circuit diagram



CDSV3-202N-G



CDSV3-202P-G

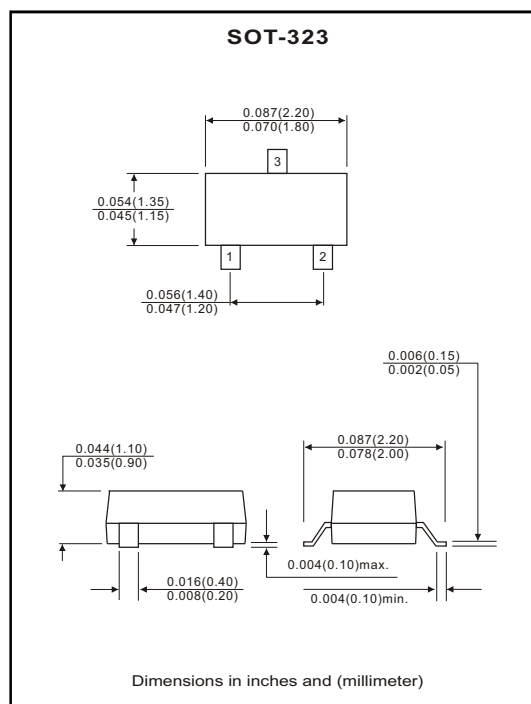

### Maximum Ratings and Electrical Characteristics

(at Ta=25°C unless otherwise noted)

Parameter	Symbol	Conditions	Value	Units
Repetitive peak reverse voltage	$V_{RRM}$		80	V
Reverse voltage	$V_R$		80	V
Peak forward current	$I_F$		300	mA
Peak surge forward current	$I_{FSM}$	T=1.0 sec	4	A
Power dissipation	$P_D$		200	mW
Maximum forward voltage	$V_F$	@ $I_F=100mA$	1.2	V
Maximum reverse current	$I_R$	@ $V_R=70V$	0.1	$\mu A$
Maximum reverse recovery time	$T_{rr}$	$I_F=I_R=5mA, V_R=6V$	4	nS
Maximum diode capacitance	$C_J$	$V_R=6V, f=1.0MHz$	3.5	pF
Maximum junction temperature	$T_J$		150	°C
Storage temperature	$T_{STG}$		-55 to +150	°C

## RATING AND CHARACTERISTIC CURVES (CDSV3-202N-G/202P-G)

Fig.1 Forward Characteristics (P type)

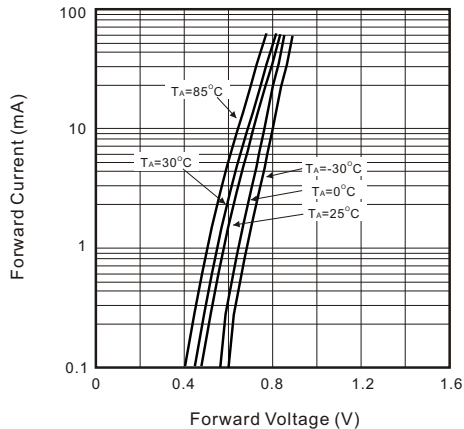

Fig.2 Reverse Characteristics (P type)

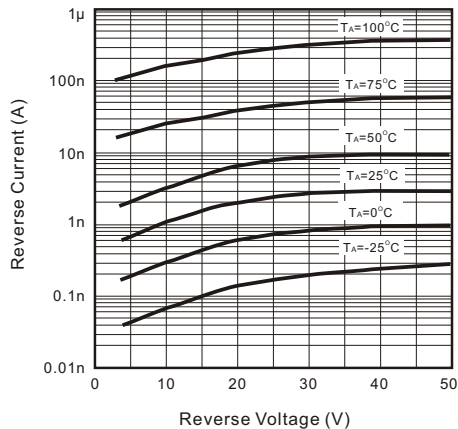

Fig.3 Forward Characteristics (N type)

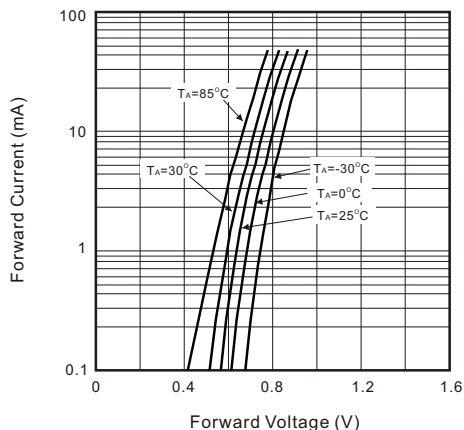

Fig.4 Reverse Characteristics (N type)

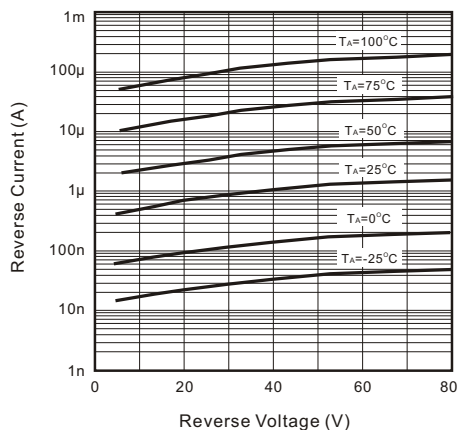

Fig.5 Capacitance Between Terminals Characteristics

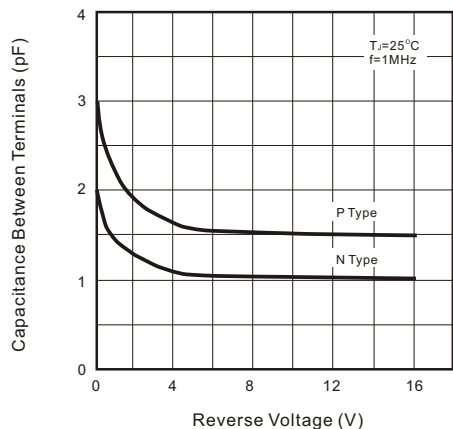

Fig.4 Power Derating Curve

