

> **Features**

- High Speed Switching
- Low On-Resistance
- No Secondary Breakdown
- Low Driving Power
- High Voltage
- V<sub>GS</sub> = ± 30V Guarantee
- Avalanche Proof

> **Applications**

- Switching Regulators
- UPS
- DC-DC converters
- General Purpose Power Amplifier

> **Outline Drawing**

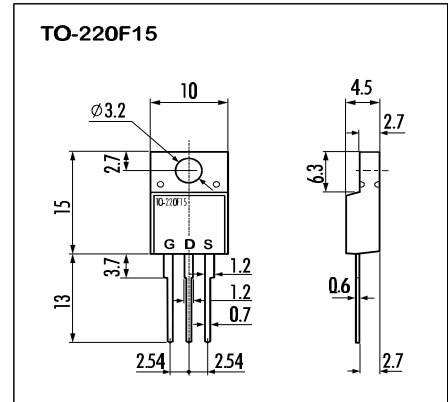

> **Maximum Ratings and Characteristics**

- Absolute Maximum Ratings (T<sub>C</sub>=25°C), unless otherwise specified

Item	Symbol	Rating	Unit
Drain-Source-Voltage	V <sub>DS</sub>	200	V
Drain-Gate-Voltage(R <sub>GS</sub> =20KΩ)	V <sub>DGR</sub>	200	V
Continuous Drain Current	I <sub>D</sub>	18	A
Pulsed Drain Current	I <sub>D(puls)</sub>	72	A
Gate-Source-Voltage	V <sub>GS</sub>	±30	V
Max. Power Dissipation	P <sub>D</sub>	40	W
Operating and Storage Temperature Range	T <sub>ch</sub>	150	°C
	T <sub>stg</sub>	-55 ~ +150	°C

> **Equivalent Circuit**

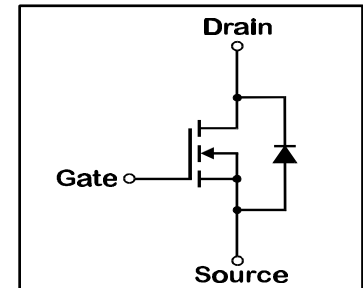

- Electrical Characteristics (T<sub>C</sub>=25°C), unless otherwise specified

Item	Symbol	Test conditions	Min.	Typ.	Max.	Unit
Drain-Source Breakdown-Voltage	V <sub>(BR)DSS</sub>	I <sub>D</sub> =1mA V <sub>GS</sub> =0V	200			V
Gate Threshold Voltage	V <sub>GS(th)</sub>	I <sub>D</sub> =1mA V <sub>DS</sub> =V <sub>GS</sub>	2,5	3,0	3,5	V
Zero Gate Voltage Drain Current	I <sub>DSS</sub>	V <sub>DS</sub> =200V T <sub>ch</sub> =25°C		10	500	μA
		V <sub>GS</sub> =0V T <sub>ch</sub> =125°C		0,2	1,0	mA
Gate Source Leakage Current	I <sub>GSS</sub>	V <sub>GS</sub> =±30V V <sub>DS</sub> =0V		10	100	nA
Drain Source On-State Resistance	R <sub>DS(on)</sub>	I <sub>D</sub> =9A V <sub>GS</sub> =10V		0,15	0,18	Ω
Forward Transconductance	g <sub>fs</sub>	I <sub>D</sub> =9A V <sub>DS</sub> =25V	4,0	9,0		S
Input Capacitance	C <sub>iss</sub>	V <sub>DS</sub> =25V		1100	1650	pF
Output Capacitance	C <sub>oss</sub>	V <sub>GS</sub> =0V		220	330	pF
Reverse Transfer Capacitance	C <sub>rss</sub>	f=1MHz		100	150	pF
Turn-On-Time t <sub>on</sub> (t <sub>on</sub> =t <sub>d(on)</sub> +t <sub>r</sub> )	t <sub>d(on)</sub>	V <sub>CC</sub> =150V		15	30	ns
	t <sub>r</sub>	I <sub>D</sub> =18A		80	120	ns
Turn-Off-Time t <sub>off</sub> (t <sub>off</sub> =t <sub>d(off)</sub> +t <sub>f</sub> )	t <sub>d(off)</sub>	V <sub>GS</sub> =10V		60	90	ns
	t <sub>f</sub>	R <sub>GS</sub> =10 Ω		40	60	ns
Avalanche Capability	I <sub>AV</sub>	L=100μH T <sub>ch</sub> =25°C	18,0			A
Diode Forward On-Voltage	V <sub>SD</sub>	I <sub>F</sub> =2xI <sub>DR</sub> V <sub>GS</sub> =0V T <sub>ch</sub> =25°C		1,5	2,25	V
Reverse Recovery Time	t <sub>rr</sub>	I <sub>F</sub> =I <sub>DR</sub> V <sub>GS</sub> =0V		165		ns
Reverse Recovery Charge	Q <sub>rr</sub>	-di <sub>F</sub> /dt=100A/μs T <sub>ch</sub> =25°C		1300		μC

- Thermal Characteristics

Item	Symbol	Test conditions	Min.	Typ.	Max.	Unit
Thermal Resistance	R <sub>th(ch-a)</sub>	channel to air			62,5	°C/W
	R <sub>th(ch-c)</sub>	channel to case			3,125	°C/W

N-channel MOS-FET			
200V	0,18Ω	18A	40W

# 2SK2522-01MR

## FAP-II Series



### > Characteristics

Typical Output Characteristics

$I_D = f(V_{DS}); 80\mu s$  pulse test;  $T_C = 25^\circ C$

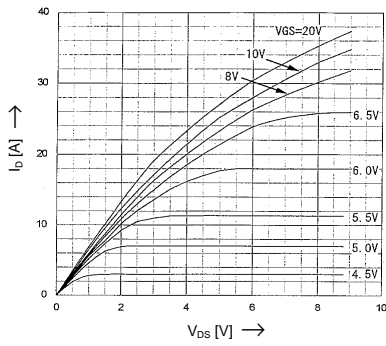

Drain-Source On-State Resistance

$R_{DS(on)} = f(T_{ch}); I_D = 9A; V_{GS} = 10V$

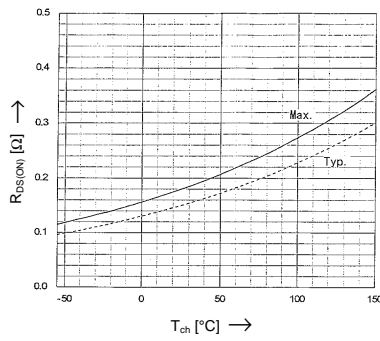

Typical Transfer Characteristics

$I_D = f(V_{GS}); 80\mu s$  pulse test;  $V_{DS} = 25V; T_{ch} = 25^\circ C$

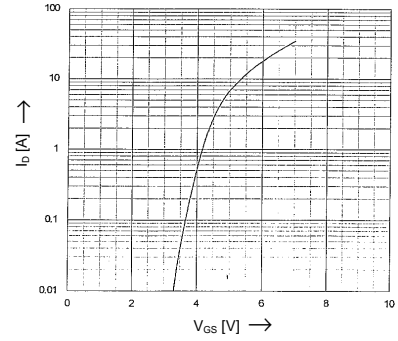

Typical Drain-Source On-State-Resistance

$R_{DS(on)} = f(I_D); 80\mu s$  pulse test;  $T_C = 25^\circ C$

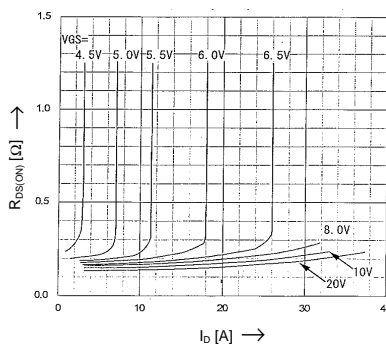

Typical Transconductance

$g_m = f(I_D); 80\mu s$  pulse test;  $V_{DS} = 25V; T_{ch} = 25^\circ C$

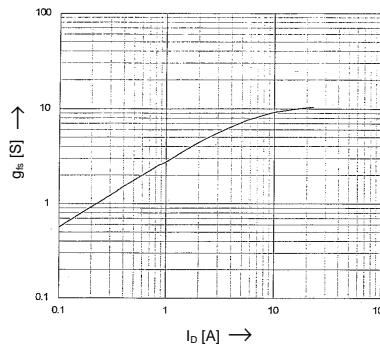

Gate Threshold Voltage

$V_{GS(th)} = f(T_{ch}); I_D = 1mA; V_{DS} = V_{GS}$

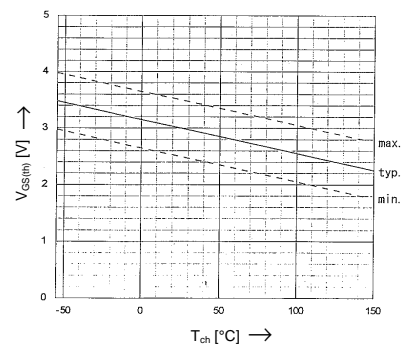

Typical Capacitances

$C = f(V_{DS}); V_{GS} = 0V; f = 1MHz$

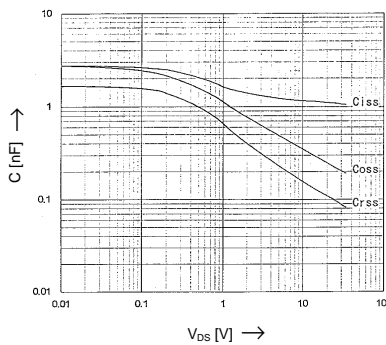

Typical Gate Charge Characteristics

$V_{GS} = f(Q_g); I_D = 18A$

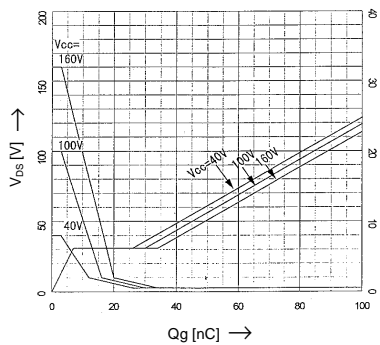

Forward Characteristics of Reverse Diode

$I_F = f(V_{SD}); 80\mu s$  pulse test;  $V_{GS} = 0V$

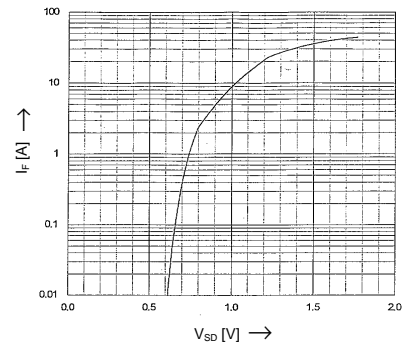

Power Dissipation

$P_D = f(T_C)$

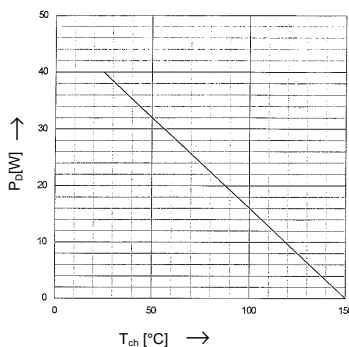

Safe Operation Area

$I_D = f(V_{DS}); D = 0.01; T_C = 25^\circ C$

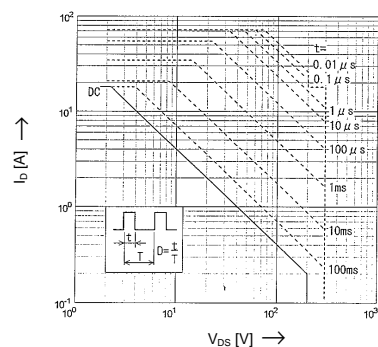

Transient Thermal Impedance

Transient Thermal Impedance

$Z_{th(j-c)} = f(t)$  parameter:  $D = t/T$

