

T-25-23

V <sub>RSM</sub> V <sub>RRM</sub>	I <sub>FRMS</sub> (maximum values for continuous operation)			
	110 A	110 A	110 A	110 A
V	40 A (80 °C)	I <sub>FAV</sub> (sin. 180; T <sub>case</sub> = ... °C; 50 Hz) 40 A (83 °C)		40 A (80 °C)
400	SKKD 40 F 04	-	-	SKMD 40 F 04
600	SKKD 40 F 06	-	-	SKMD 40 F 06
800	SKKD 40 F 08	SKKD 40 M 08	SKFH 30 /08..	SKMD 40 F 08
1000	SKKD 40 F 10	-	SKFH 30 /10..	SKMD 40 F 10
1200	-	SKKD 40 M 12	SKFH 30 /12..	-
1400	-	SKKD 40 M 14	-	-
1500	-	SKKD 40 M 15	-	-

**SEMIPACK® 1**  
Fast Thyristor/ Diode  
Modules

SKKD 40 F SKMD 40 F  
SKKD 40 M SKFH 30

Diode data<sup>1)</sup>

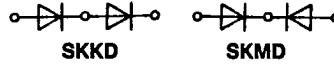
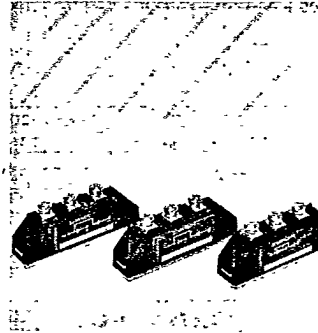

Symbol	Conditions	SKKD 40 F SKMD 40 F	SKKD 40 M SKFH 30 <sup>1)</sup>
I <sub>FAV</sub>	sin. 180; T <sub>case</sub> = 85 °C	36 A	38 A
I <sub>FSM</sub>	T <sub>vj</sub> = 25 °C T <sub>vj</sub> = 125 °C	1100 A 940 A	800 A 700 A
i <sup>2</sup> t	T <sub>vj</sub> = 25 °C T <sub>vj</sub> = 125 °C	6000 A <sup>2</sup> s 4400 A <sup>2</sup> s	3200 A <sup>2</sup> s 2450 A <sup>2</sup> s
t <sub>rr</sub>	T <sub>vj</sub> = 25 °C; I <sub>F</sub> = 1 A; -di <sub>F</sub> /dt = 15 A/μs; V <sub>R</sub> = 30 V	200 ns	1 μs
Q <sub>rr</sub>	T <sub>vj</sub> = 125 °C; I <sub>F</sub> = 100 A; -di <sub>F</sub> /dt = 30 A/μs; V <sub>R</sub> = 30 V	3 μC	20 μC
I <sub>RM</sub>		10 A	20 A
I <sub>R</sub>	T <sub>vj</sub> = 25 °C; V <sub>R</sub> = V <sub>RRM</sub> T <sub>vj</sub> = 125 °C; V <sub>R</sub> = V <sub>RRM</sub>	0,5 mA 50 mA	0,5 mA 15 mA
V <sub>F</sub>	T <sub>vj</sub> = 25 °C; I <sub>F</sub> = 150 A	2,0 V	1,85 V
V <sub>(TO)</sub>	T <sub>vj</sub> = 125 °C	1,2 V	1,0 V
r <sub>r</sub>	T <sub>vj</sub> = 125 °C	4 mΩ	5 mΩ
R <sub>thjc</sub> R <sub>thch</sub>	} per diode/per module	0,7 °C/W/0,35 °C/W	0,2 °C/W/0,1 °C/W
T <sub>vj</sub> T <sub>stg</sub>		-40 ... +125 °C -40 ... +125 °C	
V <sub>isol</sub>	a. c. 50 Hz; r.m.s.; 1 s/1 min.	3000 V~ /2500 V~	
M <sub>1</sub> M <sub>2</sub>	Case to heatsink } SI units/ Busbars to terminals } US units	5 Nm/44 lb. in ± 15 % 3 Nm/26 lb. in. ± 15 %	
w	approx.	120 g	
Case	→ page B 2-12	SKKD SKMD SKFH	A 10 A 11 A 8

**Features**

- Heat transfer through ceramic isolated metal baseplate
- Hard soldered joints for high reliability
- UL recognized, file no. E 63 532

**Typical Applications**

- Self-commutated inverters
- DC choppers
- AC motor speed control
- Inductive heating
- Uninterruptible power supplies
- Electronic welders
- General power switching applications

<sup>1)</sup> For the data of the thyristor see page B 2-33

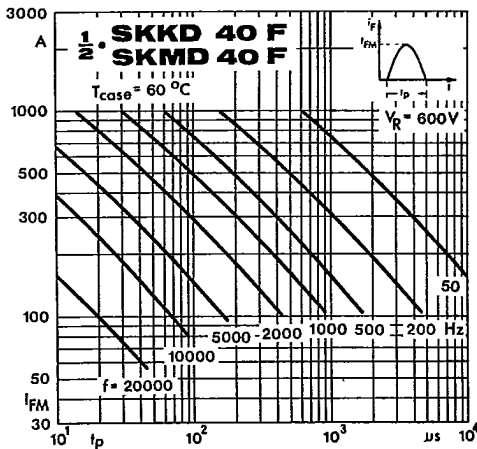

Fig. 12 a Rated sinusoidal peak forward current

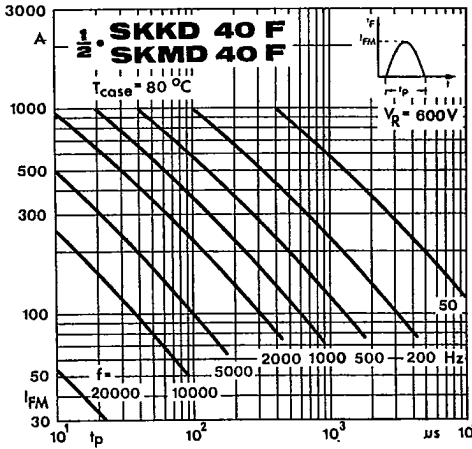

Fig. 12 b Rated sinusoidal peak forward current

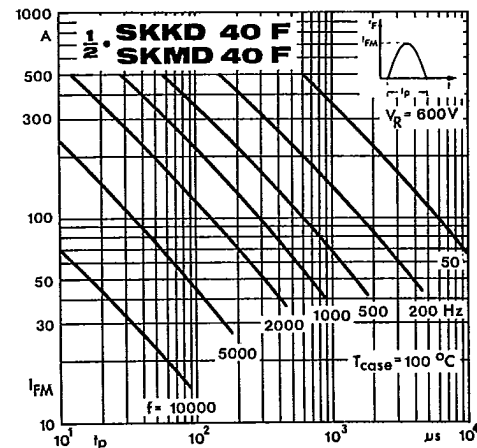

Fig. 12 c Rated sinusoidal peak forward current

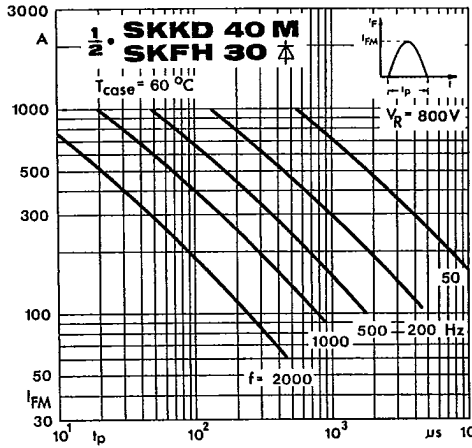

Fig. 12 d Rated sinusoidal peak forward current

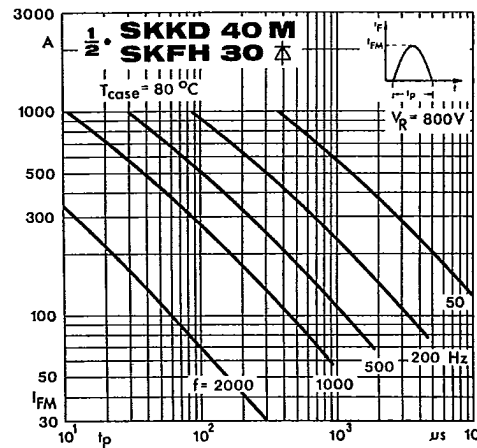

Fig. 12 e Rated sinusoidal peak forward current

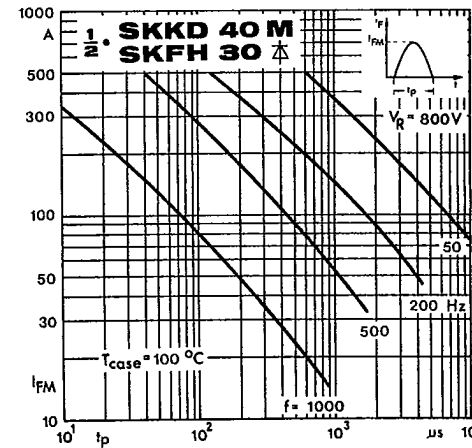

Fig. 12 f Rated sinusoidal peak forward current

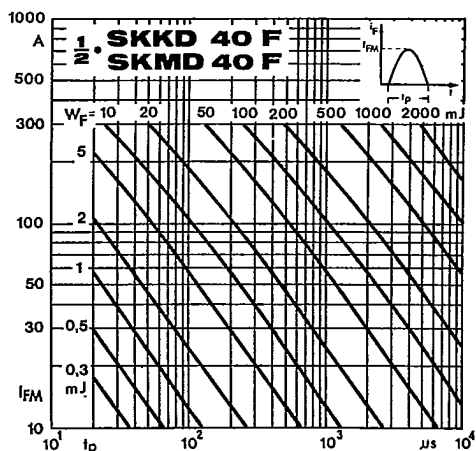

Fig. 13 a Forward energy dissipation, sinusoidal

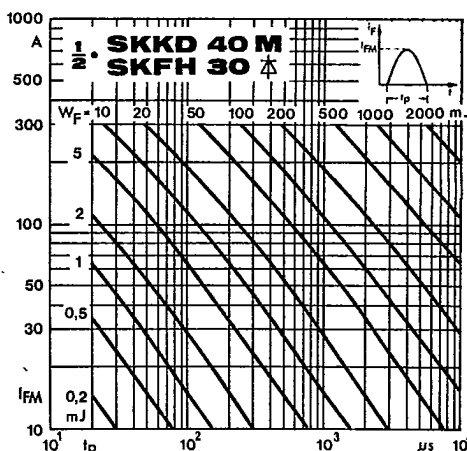

Fig. 13 b Forward energy dissipation, sinusoidal

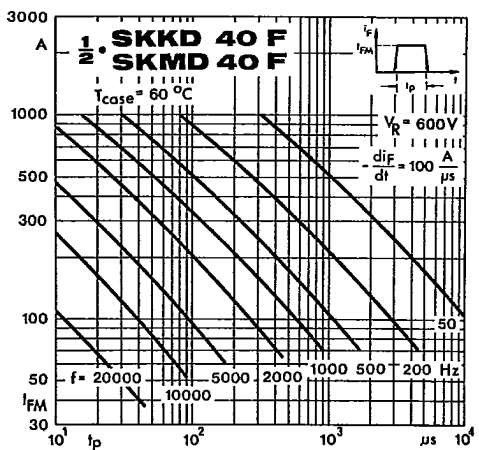

Fig. 14 a Rated rectangular peak forward current

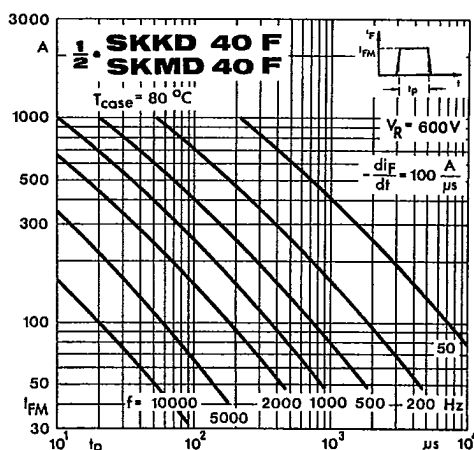

Fig. 14 b Rated rectangular peak forward current

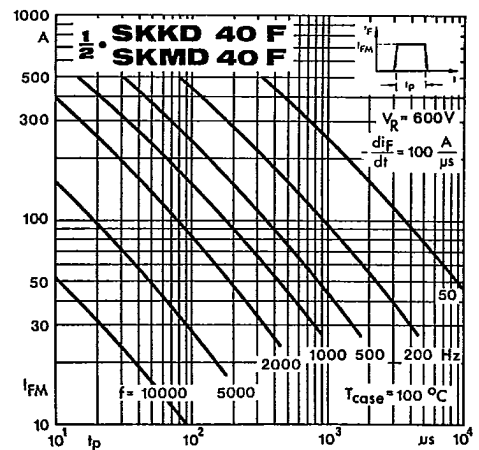

Fig. 14 c Rated rectangular peak forward current

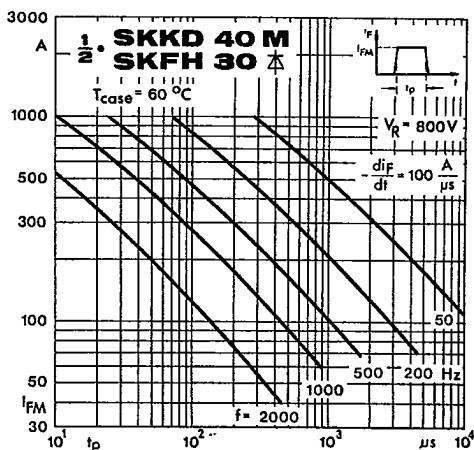

Fig. 14 d Rated rectangular peak forward current

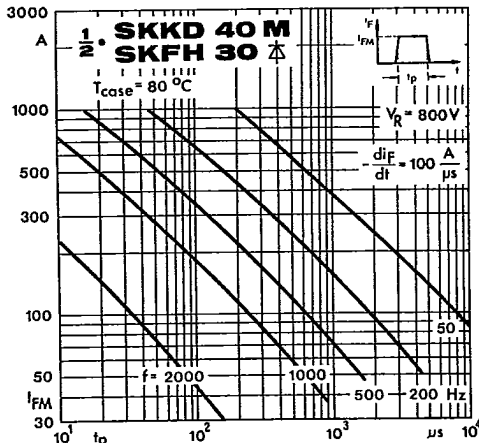

Fig. 14 e Rated rectangular peak forward current

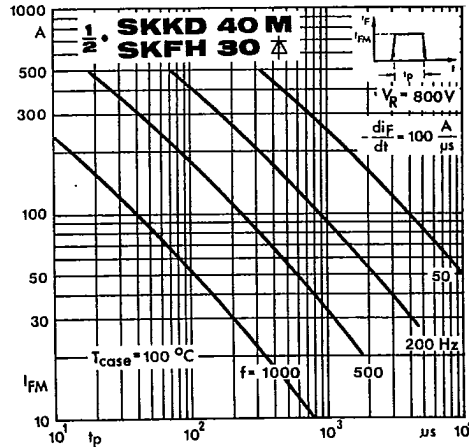

Fig. 14 f Rated rectangular peak forward current

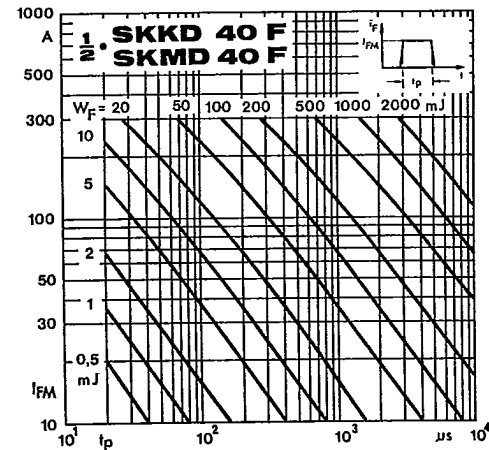

Fig. 15 a Forward energy dissipation, rectangular

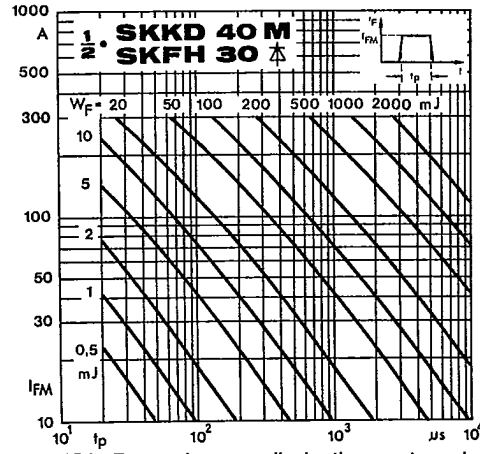

Fig. 15 b Forward energy dissipation, rectangular

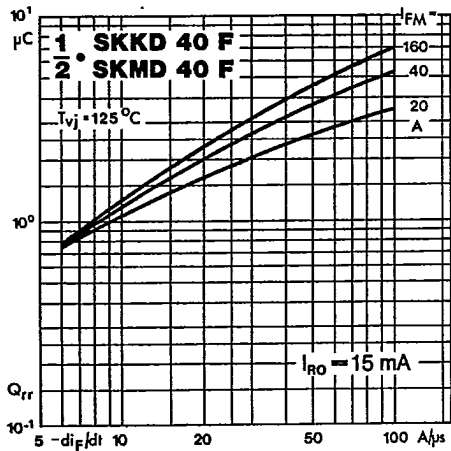

Fig. 16 a Recovered charge vs. current decrease

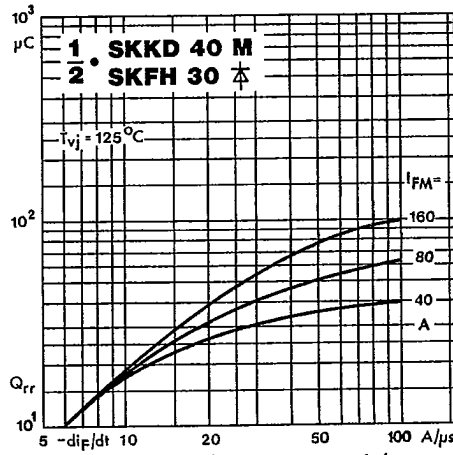

Fig. 16 b Recovered charge vs. current decrease

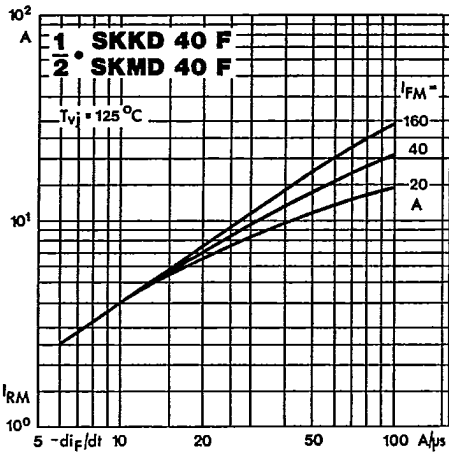

Fig. 17 a Peak recovery current vs. current decrease

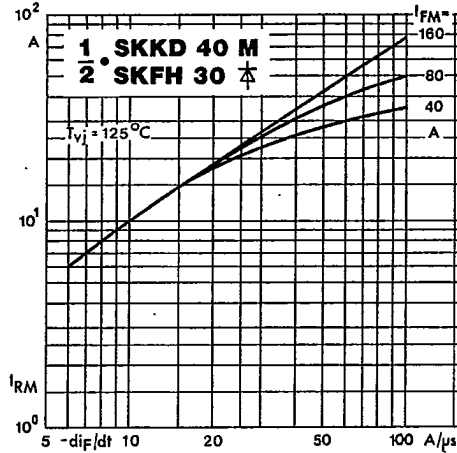

Fig. 17 b Peak recovery current vs. current decrease

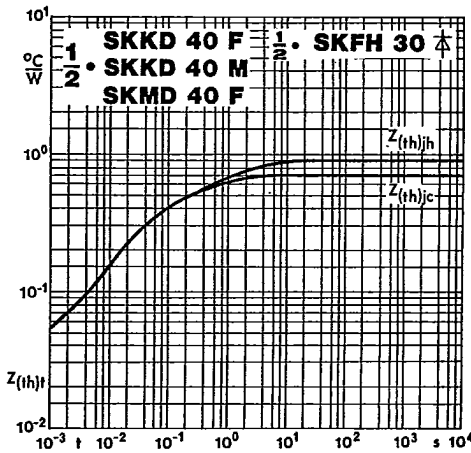

Fig. 18 Transient thermal impedance vs. time

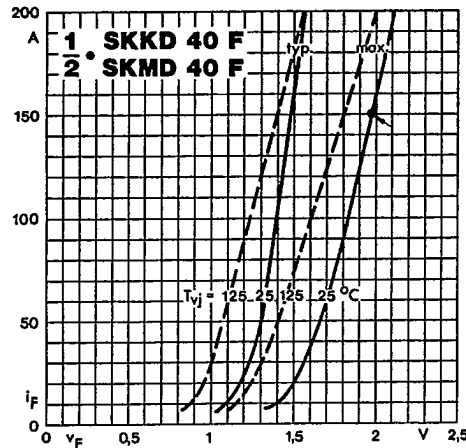

Fig. 19 a Forward characteristics

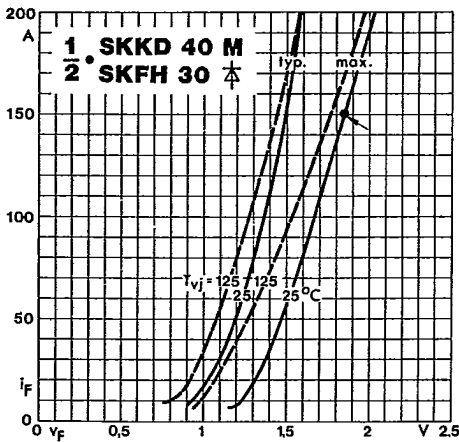

Fig. 19 b Forward characteristics

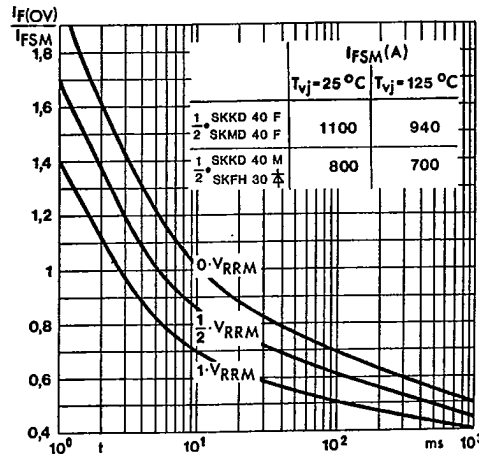
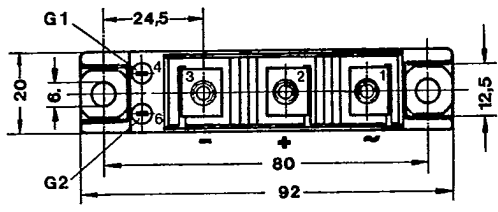
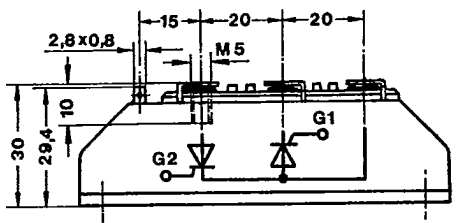

Fig. 20 Surge overload current vs. time

**SKFT 30, 40, 60** IEC 192-2: A 77 A  
 Case A 5 JEDEC: TO-240 AA  
 SEMIPACK® 1 UL recognized, file no. E 63 532



Dimensions in mm

**SKFH 30, 40, 60** IEC 192-2: A 77 A  
 Case A 8 JEDEC: TO-240 AA  
 SEMIPACK® 1 UL recognized, file no. E 63 532

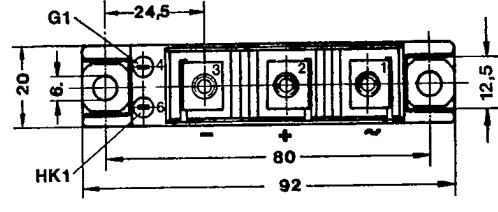
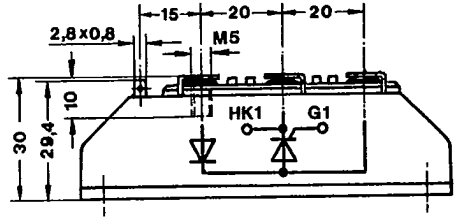

Dimensions in mm

**SKKD 40 F, 40 M, 42 F, 105 F, 115 F**  
 Case A 10 UL recognized, file no. E 63 532

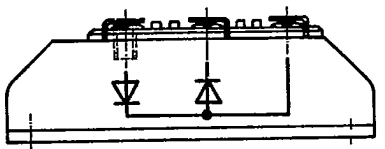

**SKKD 50 E**  
 Case A 20

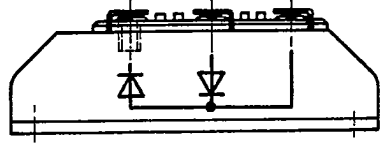

**SKMD 40 F** UL recognized, file no. E 63 532  
 Case A 11

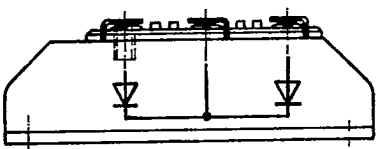

**SKMD 42 F, 105 F**  
 Case A 33

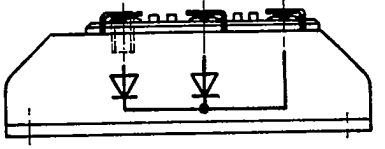

**SKND 50 E**  
 Case A 19

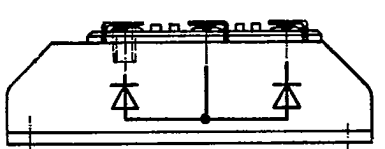

**SKND 42 F, 105 F**  
 Case A 37

