



POWER-MOS FET

FIELD EFFECT POWER TRANSISTOR

IRFD122, 123

1.1 AMPERES
100, 60 VOLTS
R_{DS(ON)} = 0.4 Ω

This series of N-Channel Enhancement-mode Power MOSFETs utilizes GE's advanced Power DMOS technology to achieve low on-resistance with excellent device ruggedness and reliability.

This design has been optimized to give superior performance in most switching applications including: switching power supplies, inverters, converters and solenoid/relay drivers. Also, the extended safe operating area with good linear transfer characteristics makes it well suited for many linear applications such as audio amplifiers and servo motors.

Features

- Polysilicon gate — Improved stability and reliability
- No secondary breakdown — Excellent ruggedness
- Ultra-fast switching — Independent of temperature
- Voltage controlled — High transconductance
- Low input capacitance — Reduced drive requirement
- Excellent thermal stability — Ease of paralleling

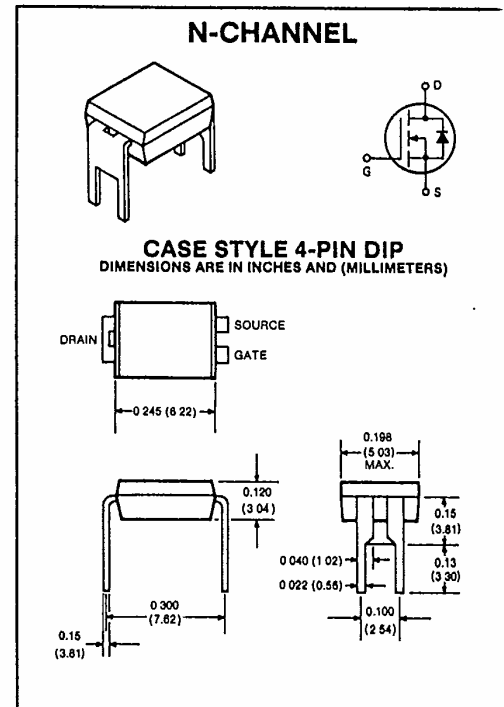

maximum ratings ($T_A = 25^\circ\text{C}$) (unless otherwise specified)

RATING	SYMBOL	IRFD122	IRFD123	UNITS
Drain-Source Voltage	V_{DSS}	100	60	Volts
Drain-Gate Voltage, $R_{GS} = 1M\Omega$	V_{DGR}	100	60	Volts
Continuous Drain Current @ $T_A = 25^\circ\text{C}^{(1)}$ @ $T_A = 100^\circ\text{C}^{(1)}$	I_D	1.1 0.70	1.1 0.70	A A
Pulsed Drain Current ⁽²⁾	I_{DM}	4.4	4.4	A
Gate-Source Voltage	V_{GS}	± 20	± 20	Volts
Total Power Dissipation @ $T_A = 25^\circ\text{C}$ Derate Above 25°C	P_D	1.0 8	1.0 8	Watts mW/ $^\circ\text{C}$
Operating and Storage Junction Temperature Range	T_J, T_{STG}	-55 to 150	-55 to 150	$^\circ\text{C}$

thermal characteristics

Thermal Resistance, Junction to Ambient ⁽¹⁾	$R_{\theta JA}$	125	125	$^\circ\text{C/W}$
Maximum Lead Temperature for Soldering Purposes: $\frac{1}{16}$ " from Case for 5 Seconds	T_L	300	300	$^\circ\text{C}$

- (1) Device mounted to vertical pc board in free air with drain lead soldered to 0.20 in² minimum copper run area.
(2) Repetitive Rating: Pulse width limited by max. junction temperature.

electrical characteristics ($T_A = 25^\circ\text{C}$) (unless otherwise specified)

CHARACTERISTIC	SYMBOL	MIN	TYP	MAX	UNIT
----------------	--------	-----	-----	-----	------

off characteristics

Drain-Source Breakdown Voltage ($V_{GS} = 0V, I_D = 250\ \mu A$)	IRFD122 IRFD123	BV_{DSS}	100 60	— —	— —	Volts
Zero Gate Voltage Drain Current ($V_{DS} = \text{Max Rating}, V_{GS} = 0V, T_A = 25^\circ\text{C}$) ($V_{DS} = \text{Max Rating}, \times 0.8, V_{GS} = 0V, T_A = 125^\circ\text{C}$)		I_{DSS}	— —	— —	250 1000	μA
Gate-Source Leakage Current ($V_{GS} = \pm 20V$)		I_{GSS}	—	—	± 500	nA

on characteristics*

Gate Threshold Voltage ($V_{DS} = V_{GS}, I_D = 250\ \mu A$)	$T_A = 25^\circ\text{C}$	$V_{GS(TH)}$	2.0	—	4.0	Volts
On-State Drain Current ($V_{GS} = 10V, V_{DS} = 10V$)		$I_{D(ON)}$	1.1	—	—	A
Static Drain-Source On-State Resistance ($V_{GS} = 10V, I_D = 0.6A$)		$R_{DS(ON)}$	—	0.30	0.40	Ohms
Forward Transconductance ($V_{DS} = 10V, I_D = 0.6A$)		g_{fs}	.63	1.0	—	mhos

dynamic characteristics

Input Capacitance	$V_{GS} = 0V$	C_{iss}	—	410	600	pF
Output Capacitance	$V_{DS} = 25V$	C_{oss}	—	160	400	pF
Reverse Transfer Capacitance	$f = 1\ \text{MHz}$	C_{rss}	—	40	100	pF

switching characteristics*

Turn-on Delay Time	$V_{DS} = 30V$	$t_{d(on)}$	—	15	—	ns
Rise Time	$I_D = 0.6A, V_{GS} = 15V$	t_r	—	30	—	ns
Turn-off Delay Time	$R_{GEN} = 50\ \Omega, R_{GS} = 12.5\ \Omega$	$t_{d(off)}$	—	25	—	ns
Fall Time	($R_{GS}\ \text{EQUIV.} = 10\ \Omega$)	t_f	—	10	—	ns

source-drain diode ratings and characteristics*

Continuous Source Current		I_S	—	—	1.1	A
Pulsed Source Current		I_{SM}	—	—	4.4	A
Diode Forward Voltage ($T_A = 25^\circ\text{C}, V_{GS} = 0V$)	$I_S = 1.1A$	V_{SD}	—	0.6	2.3	Volts
Reverse Recovery Time ($I_S = 1.3A, di_s/dt = 100A/\mu s, T_A = 125^\circ\text{C}$)		t_{rr} Q_{RR}	— —	75 0.7	—	ns μC

*Pulse Test: Pulse width $\leq 300\ \mu s$, duty cycle $\leq 2\%$

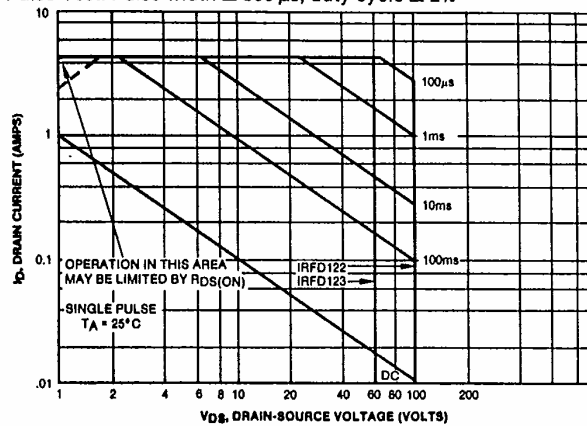

MAXIMUM SAFE OPERATING AREA

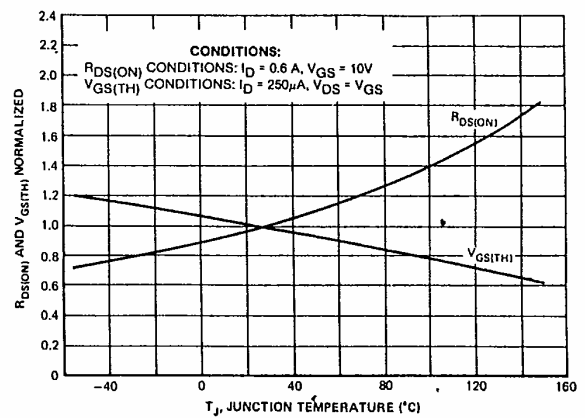

TYPICAL NORMALIZED $R_{DS(ON)}$ AND $V_{GS(TH)}$ VS. TEMP.