



## Power Bridge Rectifiers

### SKD 51

#### Features

- Glass passivated silicon chips
- Fast-on terminals for pcb solder or plug on connections
- Sturdy insulated metal base plate
- Low thermal impedance through use of direct copper bonded aluminum substrate
- Blocking voltage up to 1800V
- High surge currents
- UL recognized, file no. E63 532

#### Typical Applications

- Three phase rectifier for power supplies
- Input rectifier for variable frequency drives
- Rectifier for DC motor field supplies
- Battery charger rectifiers
- Recommended snubber network:  
RC: 0.1  $\mu$ F, 50  $\Omega$  ( $P_R = 1$  W)

- 1) For solder connection. Permissible current for plug connection see DIN IEC 760E and DIN 46249 part 1
- 2) Freely suspended or mounted on an insulator
- 3) Mounted on a painted metal sheet of min. 250 x 250 x 1 mm

$V_{RSM}$ V	$V_{RRM}, V_{DRM}$ V	$I_D = 50^{1)}$ A (full conduction) ( $T_c = 127^\circ\text{C}$ )
500	400	SKD 51/04
900	800	SKD 51/08
1300	1200	SKD 51/12
1500	1400	SKD 51/14
1700	1600	SKD 51/16
1900	1800	SKD 51/18

Symbol	Conditions	Values	Units
$I_D$	$T_c = 127^\circ\text{C}$	50	A
	$T_a = 45^\circ\text{C}$ ; isolated <sup>2)</sup>	7	A
	$T_a = 45^\circ\text{C}$ ; chassis <sup>3)</sup>	18	A
	$T_a = 45^\circ\text{C}$ ; R4A/120	27	A
	$T_a = 45^\circ\text{C}$ ; P5A/100	31	A
$I_{FSM}$	$T_{vj} = 25^\circ\text{C}$ ; 10 ms	775	A
	$T_{vj} = 150^\circ\text{C}$ ; 10 ms	700	A
$i^2t$	$T_{vj} = 25^\circ\text{C}$ ; 8,3 ... 10 ms	3000	A <sup>2</sup> s
	$T_{vj} = 150^\circ\text{C}$ ; 8,3 ... 10 ms	2450	A <sup>2</sup> s
$V_F$	$T_{vj} = 25^\circ\text{C}$ ; $I_F = 75$ A	max. 1,45	V
$V_{(TO)}$	$T_{vj} = 150^\circ\text{C}$	max. 0,8	V
$r_T$	$T_{vj} = 150^\circ\text{C}$	max. 8,5	m $\Omega$
$I_{RD}$	$T_{vj} = 25^\circ\text{C}$ ; $V_{DD} = V_{DRM}$ ; $V_{RD} = V_{RRM}$	max. 0,2	mA
	$T_{vj} = 150^\circ\text{C}$ ; $V_{RD} = V_{RRM}$	4	mA
$t_{rr}$	$T_{vj} = 25^\circ\text{C}$ ; $I_F = I_R = 1$ A	5	$\mu$ s
$R_{th(j-c)}$	per diode	1,1	K/W
	total	0,183	K/W
	$R_{th(c-s)}$	0,1	K/W
	$R_{th(j-a)}$	9 (3,15)	K/W
	$T_{vj}$	- 40 ... +150	$^\circ\text{C}$
$T_{stg}$	- 40 ... +125	$^\circ\text{C}$	
$V_{isol}$	a. c. 50 Hz; r.m.s.; 1 s / 1 min. to heatsink	3600 ( 3000 )	V
$M_s$		4,5 $\pm$ 15 %	Nm
$M_t$			
m		97	g
Case		G 51	

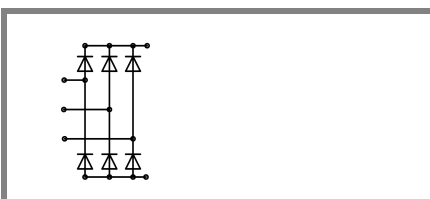

SKD

# SKD 51

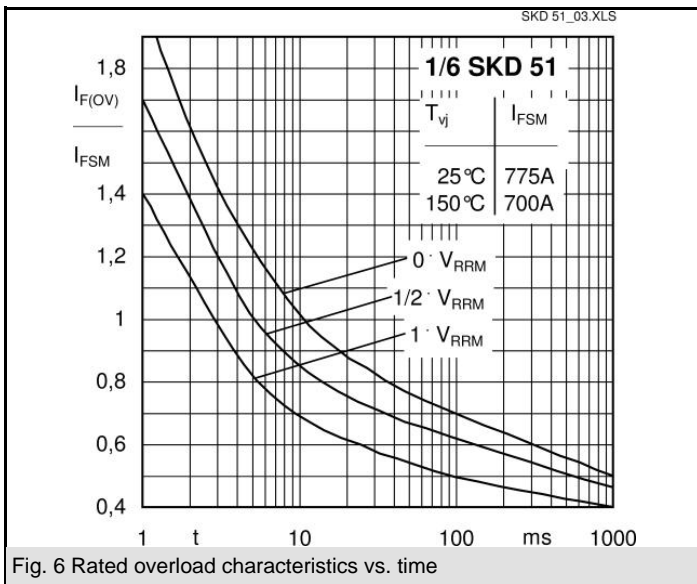
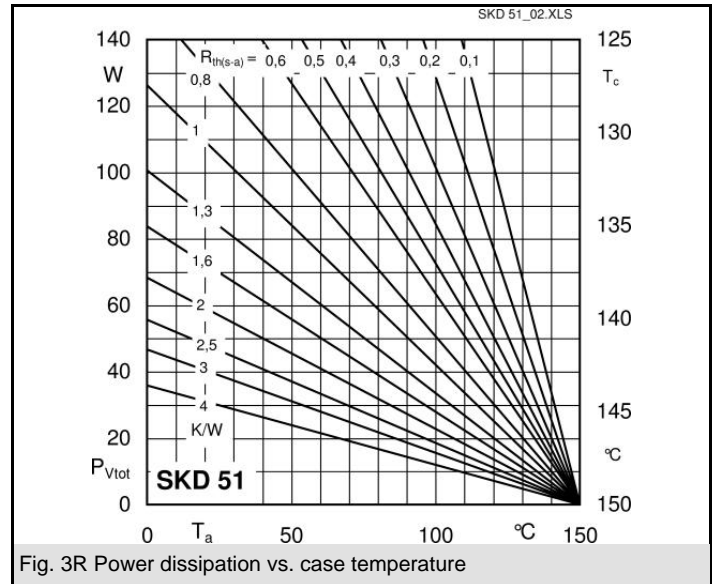
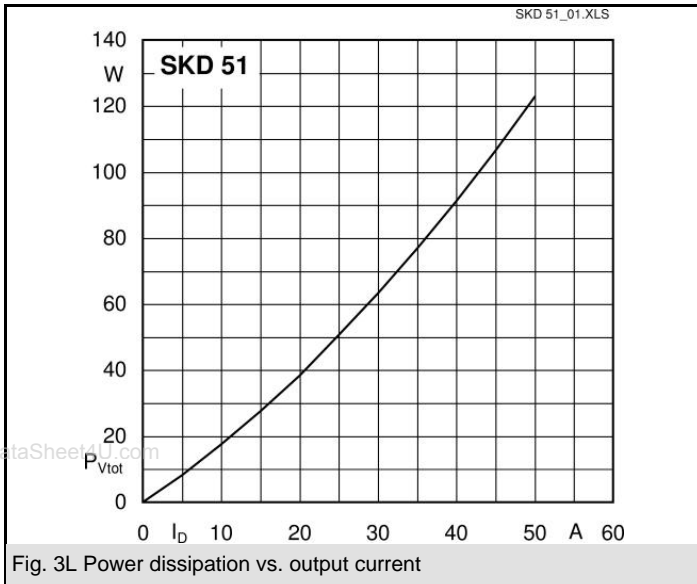

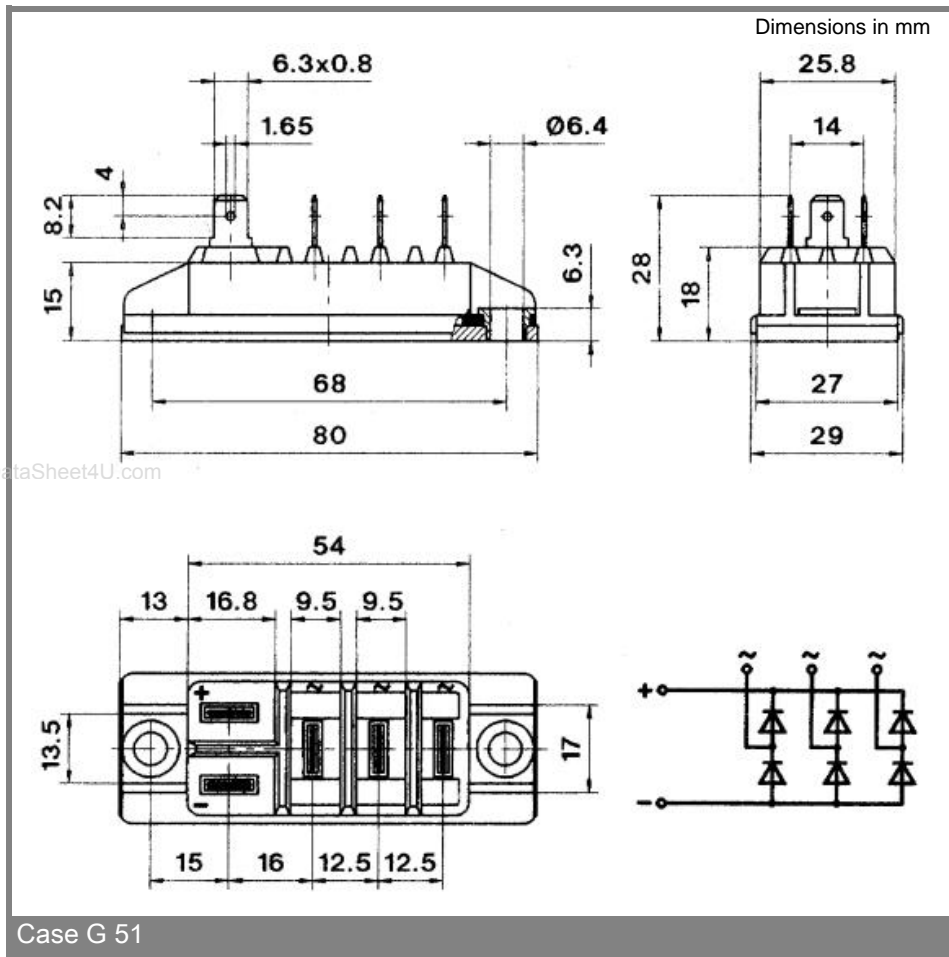

Case G 51

This technical information specifies semiconductor devices but promises no characteristics. No warranty or guarantee expressed or implied is made regarding delivery, performance or suitability.