

Ultra Low Current XO 10 MHz to 52 MHz

FEATURES

- Low phase noise (-145 dBc @ 10kHz offset).
- CMOS output with OE tri-state control.
- Ultra Low current consumption (<2mA, at 27MHz, 3.3V)
- 10 to 52MHz fundamental or 3rd OT crystal input.
- 12mA drive capability at TTL output.
- Low jitter (RMS): 2.5ps period jitter.
- 1.8V, 2.5V and 3.3V DC operation.
- Available in 6 pin SOT23

PIN ASSIGNMENT

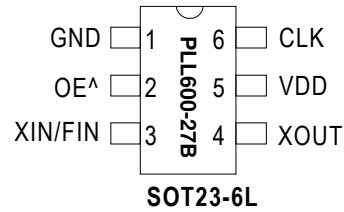

OE LOGIC SELECTION TABLE

OE^	OUTPUT
0	Disabled - osc. off
1(default)	Enabled

^ Internal Pull-up, default value is '1' when not connected.

DESCRIPTION

The PLL600-27B form a low cost family of XO IC's, designed to consume the lowest current on the market for the 10MHz to 52MHz range. It accepts fundamental resonant mode crystal input from 10 to 52MHz. Providing less than -145 dBc at 10kHz offset at 30MHz and with a very low jitter (2.5 ps RMS period jitter) makes this chip ideal for applications requiring low current frequency sources.

BLOCK DIAGRAM

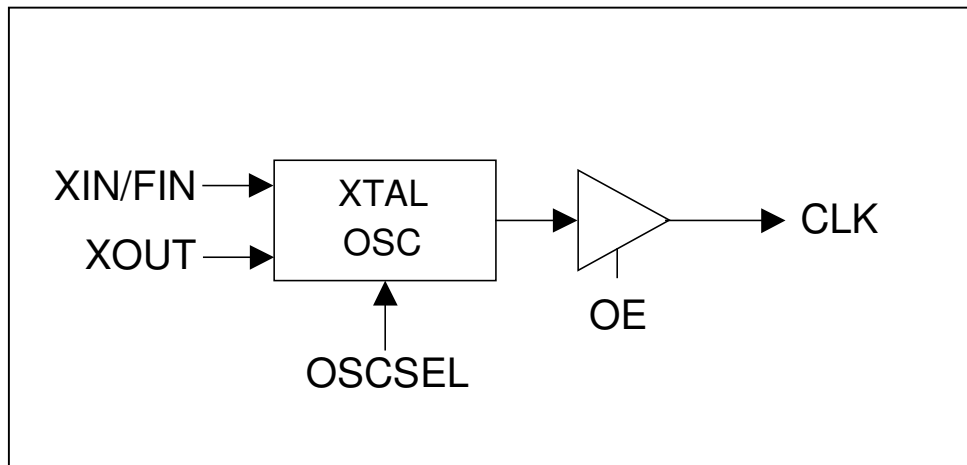

Ultra Low Current XO 10 MHz to 52 MHz
PACKAGE PIN ASSIGNMENT

Name	Pin No	Type	Description
	SOT23-6L		
GND	1	P	Ground connection.
OE	2	I	Output Enable input. See Table on page 1.
XIN/FIN	3	I	Crystal input or reference clock input pin.
XOUT	4	O	Crystal output. Do Not Connect when using Reference Clock input.
VDD	5	P	Power supply connection.
CLK	6	O	Output clock.

OE has internal pull-up resistor, so the default value is '1' when not connected.

ELECTRICAL SPECIFICATIONS
1. Absolute Maximum Ratings

PARAMETERS	SYMBOL	MIN.	MAX.	UNITS
Supply Voltage	V_{DD}		4.6	V
Input Voltage, dc	V_I	-0.5	$V_{DD}+0.5$	V
Output Voltage, dc	V_O	-0.5	$V_{DD}+0.5$	V
Storage Temperature	T_S	-65	150	°C
Ambient Operating Temperature*	T_A	-40	85	°C
Junction Temperature	T_J		125	°C
Lead Temperature (soldering, 10s)			260	°C
ESD Protection, Human Body Model			2	kV

Exposure of the device under conditions beyond the limits specified by Maximum Ratings for extended periods may cause permanent damage to the device and affect product reliability. These conditions represent a stress rating only, and functional operations of the device at these or any other conditions above the operational limits noted in this specification is not implied.

* **Note:** Operating Temperature is guaranteed by design for all parts (COMMERCIAL and INDUSTRIAL), but tested for COMMERCIAL grade only.

Ultra Low Current XO 10 MHz to 52 MHz
2. AC Electrical Specifications

PARAMETERS	CONDITIONS	MIN.	TYP.	MAX.	UNITS
Input Crystal Frequency		10		52	MHz
Settling time	At power-up (V _{DD} reaches 1.62V)			10	ms
	Disable to enable, osc. Off			10	ms
	Disable to enable, osc. On			500	μs
Output Clock Rise/Fall Time	0.8V ~ 2.0V with 10 pF load		1.15		ns
	0.3V ~ 3.0V with 15 pF load		2.4		
VDD sensitivity	Frequency vs. V _{DD} +/- 10%	0.8		0.8	ppm
Output Clock Duty Cycle	Measured @ 50% V _{DD}	45	50	55	%

3. Jitter and Phase Noise Specifications

PARAMETERS	CONDITIONS	MIN.	TYP.	MAX.	UNITS
RMS Period Jitter (1 sigma – 10,000 samples)	With capacitive decoupling between V _{DD} and GND.		2.1	2.5	ps
Phase Noise relative to carrier	27MHz @100Hz offset		-108		dBc/Hz
Phase Noise relative to carrier	27MHz @1kHz offset		-135		dBc/Hz
Phase Noise relative to carrier	27MHz @10kHz offset		-147		dBc/Hz
Phase Noise relative to carrier	27MHz @100kHz offset		-148		dBc/Hz
Phase Noise relative to carrier	27MHz @1MHz offset		-148		dBc/Hz

Ultra Low Current XO 10 MHz to 52 MHz
4. DC Specification

PARAMETERS	SYMBOL	CONDITIONS	MIN.	TYP.	MAX.	UNITS
Supply Current, Dynamic, with Loaded Outputs (at VDD = 3.3V)	I _{DD}	At 10MHz, Cload=15pF		1.3	1.5	mA
		At 13.5MHz, Cload=15pF		1.5	1.7	
		At 17.7MHz, Cload=15pF		1.7	2.0	
		At 27MHz, Cload=15pF		2.3	2.7	
		At 48MHz, Cload=15pF		4.0	4.6	
Operating Voltage	V _{DD}		1.62		3.63	V
Output High Voltage	V _{OH}	I _{OH} = -12mA (3.3V)	2.4			V
Output Low Voltage	V _{OL}	I _{OL} = 12mA (3.3V)			0.4	V
Output High Voltage at CMOS level	V _{OHC}	I _{OH} = -4mA	V _{DD} - 0.4			V
Output drive current		At TTL level (3.3V)	12	17		mA
Short Circuit Current		(3.3V)		±50		mA

5. Crystal Specifications

PARAMETERS	SYMBOL	MIN.	TYP.	MAX.	UNITS
Crystal Resonator Frequency	F _{XIN}	10		52	MHz
Crystal Loading Rating	C _{L (xtal)}		8.5		pF
Maximum Sustainable Drive Level				200	μW
Operating Drive Level			50		μW
C0 (for frequencies below 30MHz)				5	pF
C0 (for frequencies above 30MHz)				4	pF
ESR	R _s			30	Ω

Note: A detailed crystal specification document is also available for this part

Ultra Low Current XO 10 MHz to 52 MHz

PACKAGE INFORMATION

SOT-23 (6L)

Symbol	Dimension in MM	
	Min.	Max.
A	1.05	1.35
A1	0.05	0.15
A2	1.00	1.20
B	0.30	0.50
C	0.08	0.20
D	2.80	3.00
E	1.50	1.70
H	2.60	3.00
L	0.35	0.55
e	0.95 BSC	

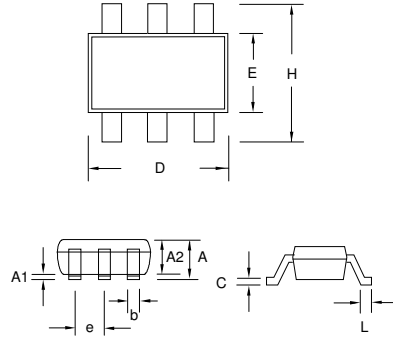

ORDERING INFORMATION

For part ordering, please contact our Sales Department:

47745 Fremont Blvd., Fremont, CA 94538, USA
Tel: (510) 492-0990 Fax: (510) 492-0991

PART NUMBER

The order number for this device is a combination of the following:
Part number, Package type and Operating temperature range

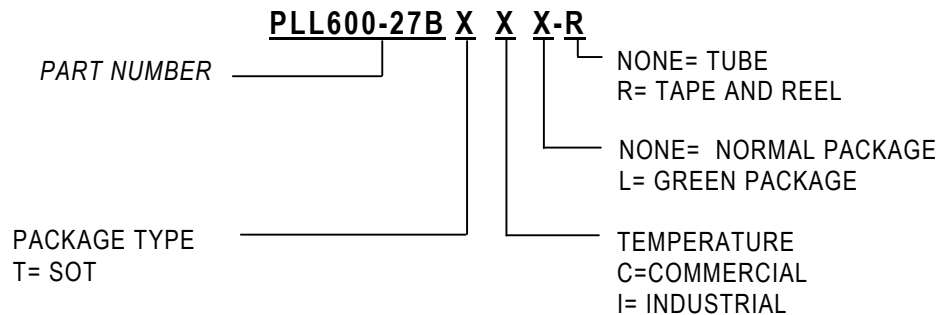

Note: PhaseLink Supports GREEN Packaging

Part / Order Number	Marking	Package Option
PLL600-27BTCL-R	P600-27BTC	6-Pin SOT (Tape and Reel)

PhaseLink Corporation, reserves the right to make changes in its products or specifications, or both at any time without notice. The information furnished by Phaselink is believed to be accurate and reliable. However, PhaseLink makes no guarantee or warranty concerning the accuracy of said information and shall not be responsible for any loss or damage of whatever nature resulting from the use of, or reliance upon this product.
LIFE SUPPORT POLICY: PhaseLink's products are not authorized for use as critical components in life support devices or systems without the express written approval of the President of PhaseLink Corporation.