

### Features

- FAST ADDRESS ACCESS TIME
  - HM-7620/21 . . . . . 70 ns MAXIMUM
  - HM-7620A/21A . . . . . 50 ns MAXIMUM
  - HM-7620B/21B . . . . . 40 ns MAXIMUM
- "THREE STATE" OR OPEN COLLECTOR OUTPUTS AND A SINGLE CHIP ENABLE INPUT
- SIMPLE HIGH SPEED PROGRAMMING PROCEDURE-ONE PULSE/BIT ASSURES FAST PROGRAMMING AND SUPERIOR RELIABILITY.
- INPUTS AND OUTPUTS TTL COMPATIBLE
- FAST ACCESS TIME-GUARANTEED FOR WORST CASE N<sup>2</sup> SEQUENCING OVER COMMERCIAL AND MILITARY TEMPERATURE AND VOLTAGE RANGES.
- PIN COMPATIBLE WITH INDUSTRY STANDARD 2K PROMs.

### Description

The HM-7620/21 are fully decoded high speed Schottky TTL 2048 bit Field Programmable ROM's in a 512 word by 4 bit/word format with open collector (HM-7620) or "three state" (HM-7621) outputs. These PROMs are available in 16 pin D.I.P. (ceramic or power plastic).

All bits are manufactured storing a logical "1" (positive logic) and can be selectively programmed for a logical "0" in any bit position.

The HM-7620/21 contain test rows and columns which are in addition to the storage array to assure high programmability and guarantee parametric and A. C. performance. The fuses in these test rows and columns are blown prior to shipment.

This PROM is intended for use in state of the art high speed logic systems. Nickel-chromium fuse technology is used on these and all other Harris Bipolar PROMs.

There is a single chip enable input on the HM-7620/21 where  $\overline{CE}$  low enables the chip.

### Pinout

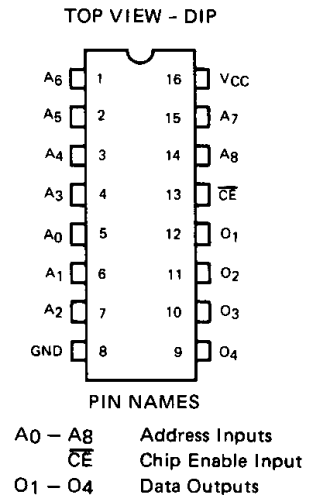

### Logic Symbol

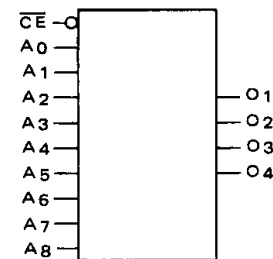

4  
BIPOLAR  
MEMORY

### Functional Diagram

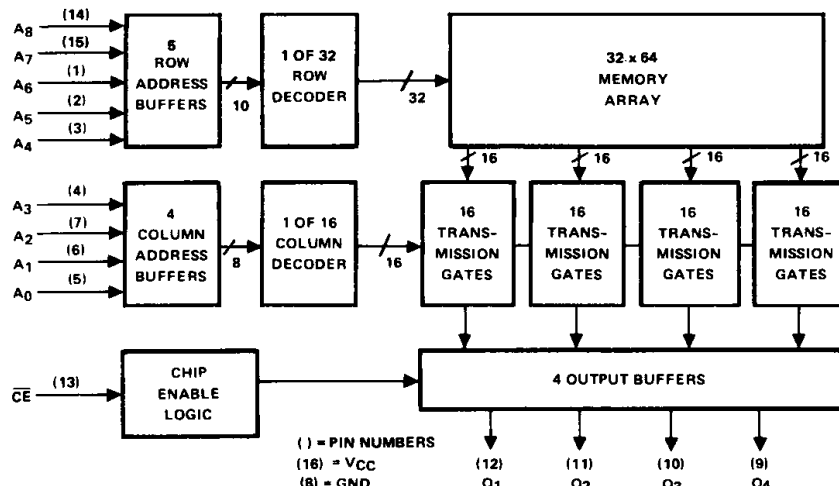

## Specifications HM-7620/21

### ABSOLUTE MAXIMUM RATINGS

Output or Supply Voltage (Operating)	-0.3 to +7.0V	Storage Temperature	-65°C to +150°C
Address/Enable Input Voltage	5.5V	Operating Temperature (Ambient)	-55°C to +125°C
Address/Enable Input Current	-20mA	Maximum Junction Temperature	+175°C
Output Sink Current	100mA		

*CAUTION: Stresses above those listed under the "Absolute Maximum Ratings" may cause permanent damage to the device. This is a stress only rating and functional operation of the device at these or at any other conditions above those indicated in the operational sections of this specification is not implied. (While programming, follow the programming specifications.)*

**D.C. ELECTRICAL CHARACTERISTICS (Operating)** HM-7620/21-5 ( $V_{CC} = 5.0V \pm 5\%$ ,  $T_A = 0^\circ C$  to  $+75^\circ C$ )  
 HM-7620/21-2/-8 ( $V_{CC} = 5.0V \pm 10\%$ ,  $T_A = -55^\circ C$  to  $+125^\circ C$ )  
 Typical measurements are at  $T_A = 25^\circ C$ ,  $V_{CC} = +5V$ .  
 NOTE: Multiple entries refer to parameter values for "A", "B"/Std.  
 Positive current defined as into device terminals.

SYMBOL	PARAMETER	MIN	TYP	MAX	UNITS	TEST CONDITIONS
I <sub>IH</sub> I <sub>IL</sub>	Address/enable Input Current	"1" "0"	- -	+40 -100/-250	$\mu A$ $\mu A$	V <sub>IH</sub> = V <sub>CC</sub> Max. V <sub>IL</sub> = 0.45V
V <sub>IH</sub> V <sub>IL</sub>	Input Threshold Voltage	"1" "0"	2.0* -	- 0.8*	V V	V <sub>CC</sub> = V <sub>CC</sub> Min. V <sub>CC</sub> = V <sub>CC</sub> Max.
V <sub>OH</sub> V <sub>OL</sub>	Output Voltage	"1" "0"	2.4 ** -	3.2 ** 0.35	V V	I <sub>OH</sub> = -2.0mA, V <sub>CC</sub> = V <sub>CC</sub> Min. I <sub>OL</sub> = +16mA, V <sub>CC</sub> = V <sub>CC</sub> Min.
I <sub>OHE</sub> I <sub>OLE</sub>	Output Disable Current	"1" "0"	- -	+40/+100 -40/-100**	$\mu A$ $\mu A$	V <sub>OH</sub> , V <sub>CC</sub> = V <sub>CC</sub> Max. V <sub>OL</sub> = 0.3V, V <sub>CC</sub> = V <sub>CC</sub> Max.
V <sub>CL</sub>	Input Clamp Voltage	-	-	-1.2	V	I <sub>IIN</sub> = -18mA
I <sub>OS</sub>	Output Short Circuit Current	-15 **	-	-100 **	mA	V <sub>CC</sub> = V <sub>CC</sub> Max. V <sub>OUT</sub> = 0.0V One Output Only for a Max. of 1 Second
I <sub>CC</sub>	Power Supply Current	-	90	120/130	mA	V <sub>CC</sub> = V <sub>CC</sub> Max. All Inputs Grounded

\* These are absolute voltages with respect to ground pin and include all overshoots due to system and/or tester noise. Do not attempt to test these values without suitable equipment.

\*\* "Three-State" only.

### A.C. ELECTRICAL CHARACTERISTICS (Operating)

Typical Measurements are at  $T_A = 25^\circ C$ ,  $V_{CC} = +5V$ .

SYMBOL	PARAMETER	HM-7620/21 - 5 5V $\pm 5\%$ 0°C to +75°C						HM-7620/21-2/8 5V $\pm 10\%$ -55°C to +125°C						UNITS
		"B"		"A"		STD		"B"		"A"		STD		
		TYP	MAX	TYP	MAX	TYP	MAX	TYP	MAX	TYP	MAX	TYP	MAX	
T <sub>AA</sub>	Address Access Time	30	40	40	50	50	70	-	55	-	70	-	85	ns
T <sub>EA</sub>	Chip Enable Access Time	-	25	-	25	-	25	-	30	-	30	-	30	ns
T <sub>DA</sub>	Chip Disable Access Time	-	25	-	25	-	25	-	30	-	30	-	30	ns

A.C. limits guaranteed for worst case N2 sequencing with maximum test frequency of 5MHz.

**CAPACITANCE:**  $T_A = 25^\circ C$

SYMBOL	PARAMETER	TYPICAL	UNITS	TEST CONDITIONS
C <sub>INA</sub> , C <sub>INCE</sub>	Input Capacitance	8	pF	V <sub>CC</sub> = 5V, V <sub>IN</sub> = 2.0V, f = 1MHz
C <sub>OUT</sub>	Output Capacitance	10	pF	V <sub>CC</sub> = 5V, V <sub>OUT</sub> = 2.0V, f = 1MHz

## HM-7620/21 SWITCHING TIME DEFINITIONS

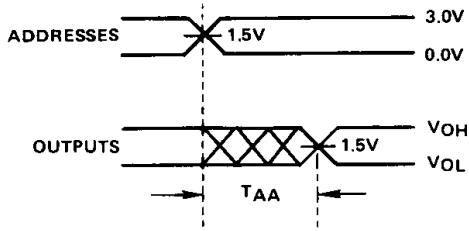

NOTE: As is common to all memory devices, output levels can be undefined during the address access period ( $T_{AA}$ ); however, the outputs are guaranteed to reach stable levels by  $T_{AA}$ . It is not recommended that outputs from this class of devices be used to drive edge triggered inputs on subsequent devices (counters, flip-flops, etc.) without proper intermediate synchronization.

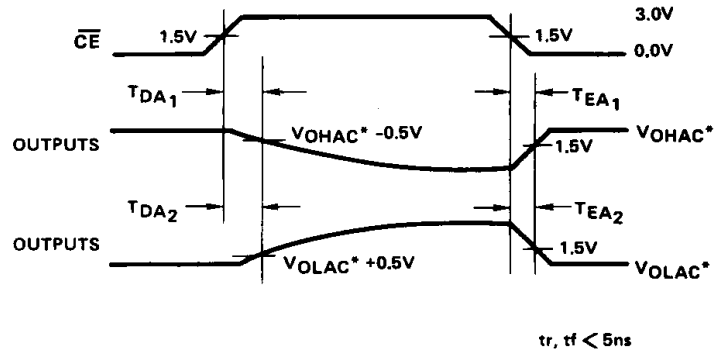

\* $V_{OLAC}$  AND  $V_{OHAC}$  ARE THE MEASURED OUTPUT VOLTAGE LEVELS WHILE ENABLED.

### A.C. TEST LOAD

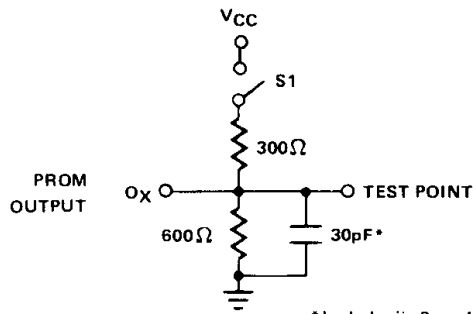

\* Includes jig & probe total capacitance

*This is the A.C. Test Load which Harris Semiconductor uses in its automatic test equipment, and it is recommended that users of Harris bipolar devices use the same or an equivalent load in performing A.C. testing.*

SYMBOL	PARAMETER	S1
$T_{AA}$	Address Access Time	Closed
* $TEA_1$	Chip Enable Access Time from "Three State" to $V_{OH}$	Open
$TEA_2$	Chip Enable Access Time to $V_{OL}$	Closed
* $TDA_1$	Chip Disable Access Time from $V_{OH}$ to "Three State"	Open
$TDA_2$	Chip Disable Access Time from $V_{OL}$	Closed

\*Applies to "Three-State" only.