

CMOS 4-BIT MICROCONTROLLER

TMP47C620F, TMP47C820F

The 47C620/820 are high speed and high performance 4-bit single chip microcomputers based on the TLC5470 series with a LCD driver and high speed timer/counters.

PART No.	ROM	RAM	PACKAGE	OTP version	PIGGYBACK
TMP47C620F	6144 × 8-bit	384 × 4-bit	QFP80	TMP47P820F	TMP47C020G
TMP47C820F	8192 × 8-bit	512 × 4-bit			

FEATURES

- ◆ 4-bit single chip microcomputer
- ◆ Instruction execution time :
 - 1.3 μ s (at 6MHz), 244 μ s (at 32.8KHz)
- ◆ 92 basic instructions
 - Table look-up instructions
 - 5-bit to 8-bit data conversion instruction
- ◆ Subroutine nesting : 15 levels max.
- ◆ 6 interrupt sources (External : 2, Internal : 4)
 - All sources have independent latches each, and multiple interrupt control is available.
- ◆ I/O port (36 pins)
 - Input 2 ports 5 pins
 - Output 2 ports 8 pins
 - I/O 6 ports 23 pins
- ◆ Interval Timer
- ◆ Two 12-bit Timer/Counters
 - Timer, event counter, and pulse width measurement mode
- ◆ Two 8-bit High speed Timer/Counters
 - Timer, event counter, frequency measurement, and pulse output mode
- ◆ Watchdog Timer
- ◆ Serial Interface with 8-bit buffer
 - Simultaneous transmission and reception capability.
 - External/internal clock, leading/trailing edge, and 4/8-bit mode
- ◆ High current outputs
 - LED direct drive capability (typ. 10mA × 8bits)
- ◆ LCD driver
 - LCD direct drive capability (max. 16-digit display at 1/4 duty LCD)
 - 1/4, 1/3 1/2 duties or static drive are programmably selectable.
- ◆ Dual-clock operation
 - High-speed/Low-power consumption operating mode
- ◆ Hold function
 - Battery/Capacitor back-up
- ◆ Real Time Emulator : BM47C820A

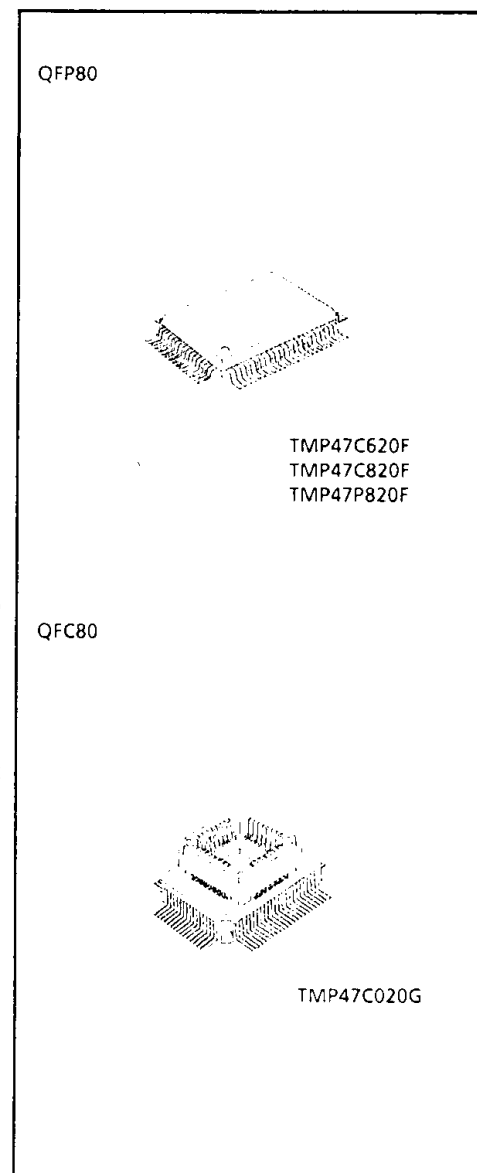

PIN ASSIGNMENT (TOP VIEW)

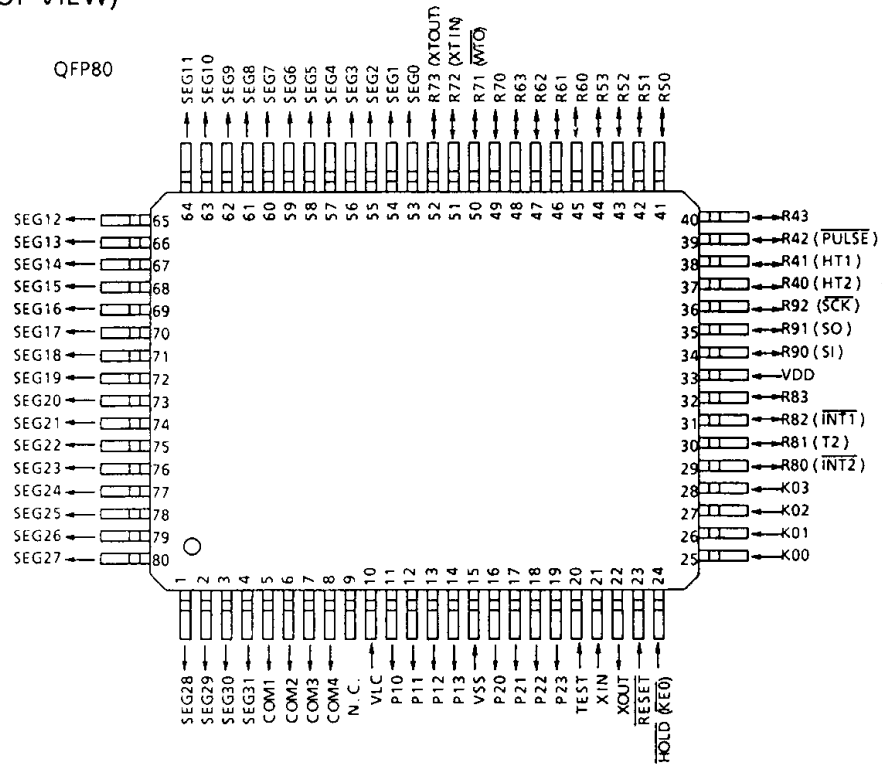

BLOCK DIAGRAM

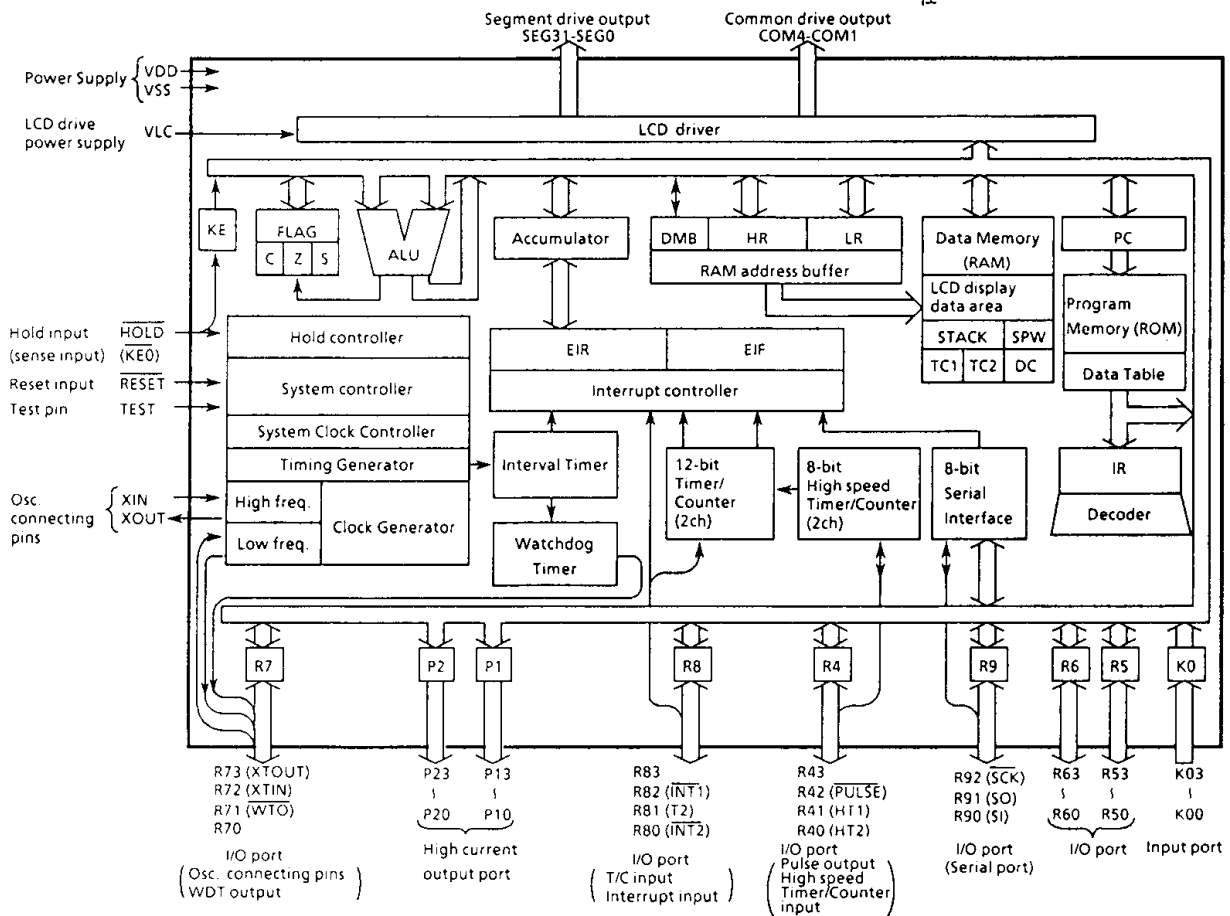

PIN FUNCTION

PIN NAME	Input/Output	FUNCTIONS		
K03 - K00	Input	4-bit input port		
P13 - P10	Output	4-bit output port with latch.		
P23 - P20		8-bit data are output by the 5-bit to 8-bit data conversion instruction [OUTB @HL].		
R43	I/O	4-bit I/O port with latch.		
R42 (PULSE)	I/O (Output)	When used as input port or high speed Timer/Counter, the latch must be set to "1".	Pulse output (High speed T/C2)	
R41 (HT1)	I/O (Input)		High speed Timer/Counter 1 input	
R40 (HT2)			High speed Timer/Counter 2 input	
R53 - R50	I/O	4-bit I/O port with latch.		
R63 - R60		When used as input port, the latch must be set to "1".		
R73 (XOUT)	I/O (Output)	4-bit I/O port with latch.	Resonator connecting pins.	
R72 (XTIN)	I/O (Input)		For inputting external clock, XIN is used and XOUT is opened.	
R71 (WTO)	I/O (Output)	When used as input port, watchdog timer output, the latch must be set to "1".	Watchdog timer output	
R70	I/O			
R83	I/O	4-bit I/O port with latch.		
R82 (INT1)		External interrupt 1 input		
R81 (T2)		I/O (Input)	When used as input port, external interrupt input pin, or Timer/Counter external input pin, the latch must be set to "1".	
R80 (INT2)			External interrupt 2 input	
R92 (SCK)	I/O (I/O)	3-bit I/O port with latch.		
R91 (SO)	I/O (Output)	When used as input port, serial port the latch must be set to "1".		
R90 (SI)				Serial data output
SEG31 - SEG0	Output	LCD Segment drive output		
COM4 - COM1		LCD Common drive output		
XIN	Input	Resonator connecting pins (high-frequency).		
XOUT	Output	For inputting external clock, XIN is used and XOUT is opened.		
RESET	Input	Reset signal input		
HOLD (KE0)	Input (Input)	Hold request/ release signal input	Sense input	
TEST	Input	Test pin for out-going test. Be opened or fixed to low level.		
VDD	Power supply	+ 5V		
VSS		0V (GND)		
VLC		LCD drive power supply		

OPERATIONAL DESCRIPTION

Concerning the 47C620/820 the configuration and functions of hardwares are described. As the description has been provided with priority on those parts differing from the 47C660/860, the technical data sheets for the 47C660/860 shall also be referred to.

1. SYSTEM CONFIGURATION

- (1) I/O Port
- (2) High speed Timer/Counter
- (3) LCD Driver

2. PERIPHERAL HARDWARE FUNCTION

2.1 I/O Ports

The 47C620/820 have 10 I/O ports (36 pins) each as follows.

- ① K0 ; 4-bit input
- ② P1, P2 ; 4-bit output
- ③ R4 ; 4-bit input/output (shared with high speed timer/counter input and pulse output)
- ④ R5, R6 ; 4-bit input/output
- ⑤ R7 ; 4-bit input/output (shared with the Low-frequency resonator connecting pin and the Watchdog timer output)
- ⑥ R8 ; 4-bit input/output (shared with external interrupt and timer/counter input)
- ⑦ R9 ; 3-bit input/output (shared with serial port)
- ⑧ KE ; 1-bit sense input (shared with hold request/release signal input)

The description has been provide with priority on ports (③ and ⑥) changed from 47C800. Table2-1 lists the port address assignments and the I/O instruction that can access the ports.

(1) Port R4 (R43-R40)

Port R4 is a 4-bit I/O port with output latch. The latch should be set to "1" for use as an input port. During reset, the latch is initialized to "1".

The R4 port is shared with the high speed Timer/Counter input pin and pulse output pin. The latches should be set to "1" when these pins are used for these functions. When used for normal I/O, the high speed Timer/Counter event counter mode, frequency measurement mode and pulse output mode should be disabled.

Port R4 (Port address OP04 / IP04)

3	2	1	0
R43	R42 (PULSE)	R41 (HT1)	R40 (HT2)

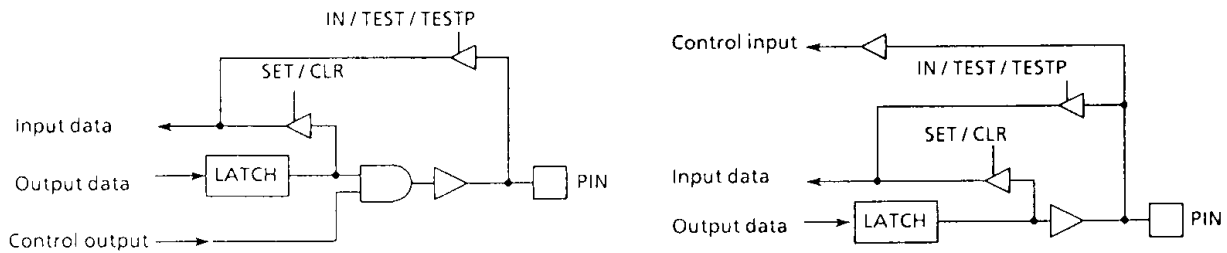

Figure 2-1. port R4

(2) R83 pin

Port R8 is shared with external interrupt input and Timer/Counter input. Timer/Counter 1 is connected to HTC1 ; therefore, there is no Timer/Counter 1 external input pin (TC1).

Port Address (**)	Port		Input/Output instructions																				
	Input (IP**)	Output (OP**)	IN %p, A	OUT A, %p	OUT #k, %p	OUTB @HL	SET %p, b	TEST %p, b	SET @L	CLR @L	TEST @L												
00H	K0 input port	—	○	—	—	—	—	—	—	—	—	—	—	—	—	—	—	—	—	—	—	—	
01	P1 output latch	P1 output port	○	—	—	—	—	—	—	—	—	—	—	—	—	—	—	—	—	—	—	—	—
02	P2 output latch	P2 output port	○	—	—	—	—	—	—	—	—	—	—	—	—	—	—	—	—	—	—	—	—
03	—	—	—	—	—	—	—	—	—	—	—	—	—	—	—	—	—	—	—	—	—	—	—
04	R4 input port (HTC input)	R4 output port (PULSE OUTPUT)	○	—	—	—	—	—	—	—	—	—	—	—	—	—	—	—	—	—	—	—	—
05	R5 input port	R5 output port	○	—	—	—	—	—	—	—	—	—	—	—	—	—	—	—	—	—	—	—	—
06	R6 input port	R6 output port	○	—	—	—	—	—	—	—	—	—	—	—	—	—	—	—	—	—	—	—	—
07	R7 input port	R7 output port	○	—	—	—	—	—	—	—	—	—	—	—	—	—	—	—	—	—	—	—	—
08	R8 input port	R8 output port	○	—	—	—	—	—	—	—	—	—	—	—	—	—	—	—	—	—	—	—	—
09	R9 input port	R9 output port	○	—	—	—	—	—	—	—	—	—	—	—	—	—	—	—	—	—	—	—	—
0A	—	—	—	—	—	—	—	—	—	—	—	—	—	—	—	—	—	—	—	—	—	—	—
0B	—	—	—	—	—	—	—	—	—	—	—	—	—	—	—	—	—	—	—	—	—	—	—
0C	HTC1 counter	HTC1 register	○	—	—	—	—	—	—	—	—	—	—	—	—	—	—	—	—	—	—	—	—
0D	HTC2 counter	HTC2 register	○	—	—	—	—	—	—	—	—	—	—	—	—	—	—	—	—	—	—	—	—
0E	SIO, clock generator and Hold status	—	○	—	—	—	—	—	—	—	—	—	—	—	—	—	—	—	—	—	—	—	—
0F	Serial receive buffer	Serial transmit buffer	○	—	—	—	—	—	—	—	—	—	—	—	—	—	—	—	—	—	—	—	—
10H	Undefined	Hold operating mode control	—	○	—	—	—	—	—	—	—	—	—	—	—	—	—	—	—	—	—	—	—
11	Undefined	—	—	—	—	—	—	—	—	—	—	—	—	—	—	—	—	—	—	—	—	—	—
12	Undefined	—	—	—	—	—	—	—	—	—	—	—	—	—	—	—	—	—	—	—	—	—	—
13	Undefined	—	—	—	—	—	—	—	—	—	—	—	—	—	—	—	—	—	—	—	—	—	—
14	Undefined	—	—	—	—	—	—	—	—	—	—	—	—	—	—	—	—	—	—	—	—	—	—
15	Undefined	Watchdog Timer control	—	○	—	—	—	—	—	—	—	—	—	—	—	—	—	—	—	—	—	—	—
16	Undefined	System clock control	—	○	—	—	—	—	—	—	—	—	—	—	—	—	—	—	—	—	—	—	—
17	Undefined	HTC1 control	—	○	—	—	—	—	—	—	—	—	—	—	—	—	—	—	—	—	—	—	—
18	Undefined	HTC2 control	—	○	—	—	—	—	—	—	—	—	—	—	—	—	—	—	—	—	—	—	—
19	Undefined	Interval Timer interrupt control	—	○	—	—	—	—	—	—	—	—	—	—	—	—	—	—	—	—	—	—	—
1A	Undefined	LCD driver control 1	—	○	—	—	—	—	—	—	—	—	—	—	—	—	—	—	—	—	—	—	—
1B	Undefined	LCD driver control 2	—	○	—	—	—	—	—	—	—	—	—	—	—	—	—	—	—	—	—	—	—
1C	Undefined	Timer/Counter 1 control	—	○	—	—	—	—	—	—	—	—	—	—	—	—	—	—	—	—	—	—	—
1D	Undefined	Timer/Counter 2 control	—	○	—	—	—	—	—	—	—	—	—	—	—	—	—	—	—	—	—	—	—
1E	Undefined	Serial interface control 1	—	○	—	—	—	—	—	—	—	—	—	—	—	—	—	—	—	—	—	—	—
1F	Undefined	Serial interface control 2	—	○	—	—	—	—	—	—	—	—	—	—	—	—	—	—	—	—	—	—	—

Note1. "—" means the reserved state. Unavailable for the user programs.

Note2. The 5-bit to 8-bit data conversion instruction [OUTB @HL], automatic access to ports P1 and P2.

Table 2-1. Port Address Assignments and Available I/O Instructions



2.2 High Speed Timer/Counter (HTC1, HTC2)

The 47C620/820 have two 8-bit high speed timer/counters for counting times or events. The event counter mode, timer mode, frequency measurement mode, and pulse output mode can be selected for the high speed timer/counters (HTC1 and HTC2).

The HTC1 can also be operated in conjunction with TC1 as a 20-bit counter. HTC2 can also output pulses. External input pins HT1 and HT2 are shared with ports R41 and R40. Pulse output pin ($\overline{\text{PULSE}}$) is shared with port R42, the corresponding R4 output latch should be set to "1" when used as external input pins and pulse output pin. R41 can be used as the normal input/output pin when HTC1 is used in the timer mode, and R40 can be used as the normal input/output pin when HTC2 is used in the pulse output mode.

2.2.1 Circuit configuration

The high speed timer/counter consists of 8-bit binary counter, preset register and clock source selector.

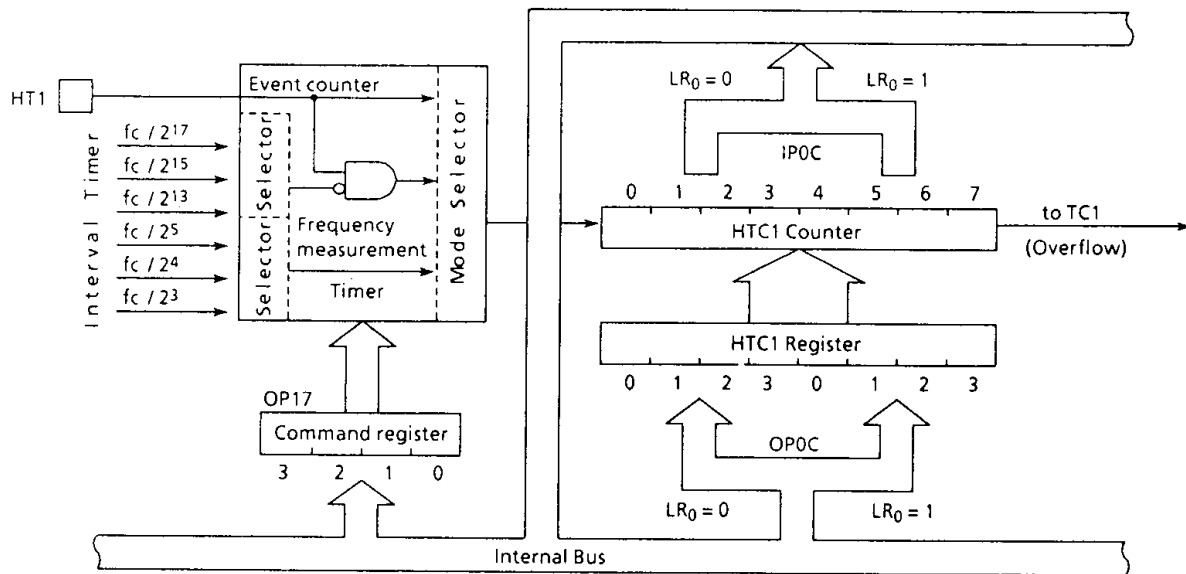

Figure 2.2. High Speed Timer/Counter 1

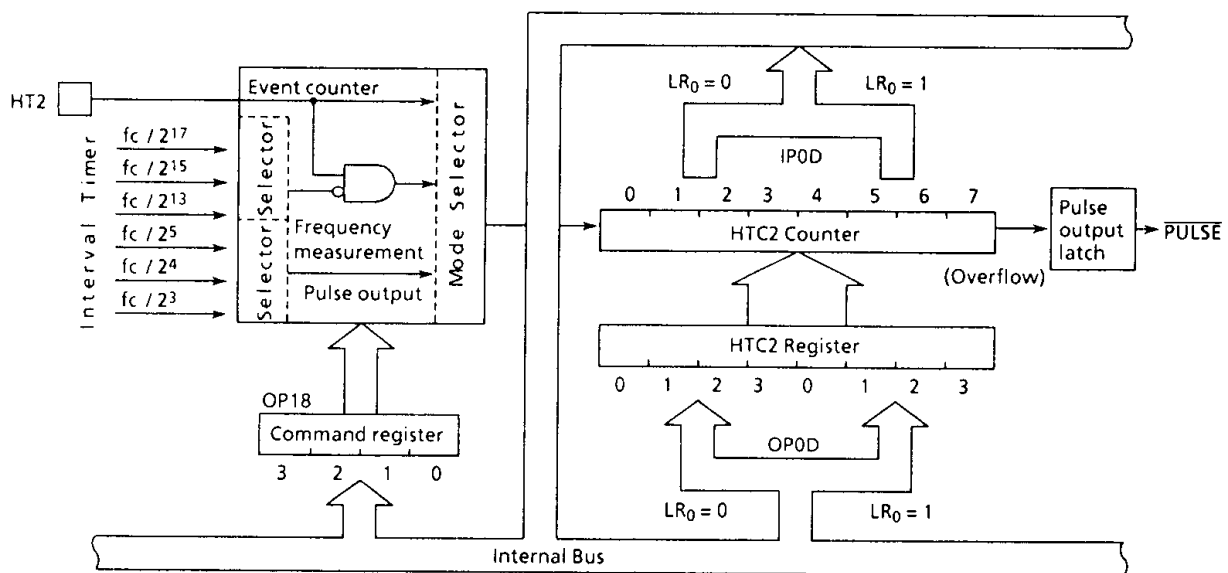

Figure 2.3. High Speed Timer/Counter 2

2.2.2 Control of High Speed Timer/Counter

The High Speed Timer/Counter is controlled by the command registers (OP17, OP18). These registers are initialized to "0" during reset.

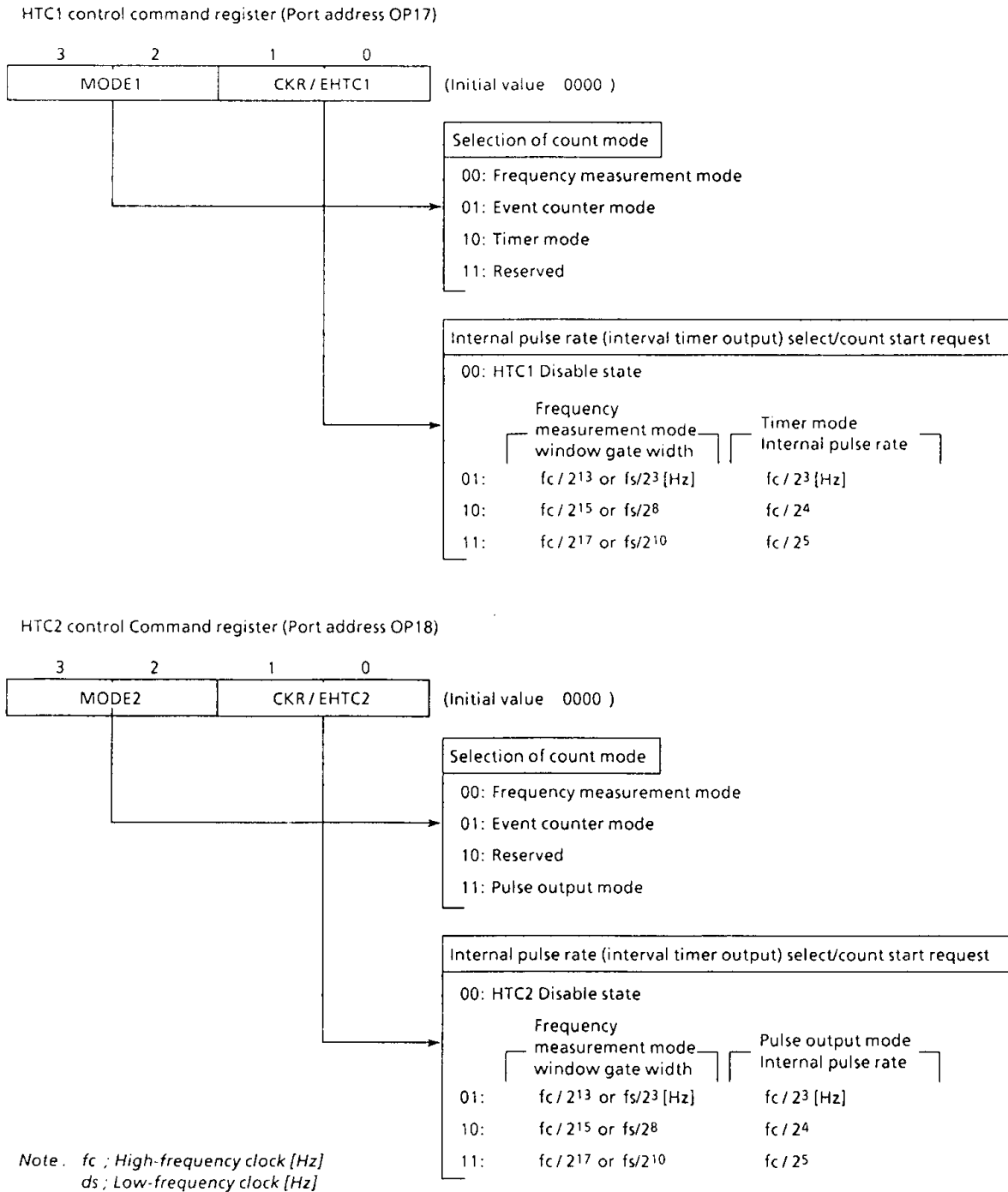

Figure 2-4. HTC1, HTC2 control Command register

2.2.3 Function of High Speed Timer/Counter

The High Speed Timer/Counters (HTC1 and HTC2) consist of presettable 8-bit binary counters and clock source selectors. Either internal or external pulses can be selected by command register as the clock source for the event counter, timer, frequency measurement and pulse output modes. HTC1 and HTC2 increment at the rising edges of the clock pulses. Counting starts at the first rise of the clock pulse after a command is loaded into the command register.

(1) Setting of preset value

Values can be preset in the 8-bit binary counter. Values can be loaded to the binary counter when counting starts or when an overflow occurs by writing them to the HTC1 and HTC2 registers. Thus, preset values can be changed when the next overflow occurs by writing them during counting. Port addresses OP0C and OP0D are used for writing preset values as shown in Table 2-2. Preset values are written to the lower 4 bits when LR₀ (bit 0 of L register) = 0 and to the upper 4 bits when LR₀ = 1. The register is initialized to "0" during reset.

Port address	LR ₀	Access register
OP0C	0	The Lower 4-bits of HTC1 register
	1	The upper 4-bits of HTC1 register
OP0D	0	The Lower 4-bits of HTC2 register
	1	The upper 4-bits of HTC2 register

Table 2-2. Writing of preset value

(2) Reading of Count Value

Count values of the 8-bit binary counter are read out from port addresses IP0C and IP0D as shown in Table 2-3. The lower 4 bits are read out when LR₀ = 0 and the upper 4 bits are read out when LR₀ = 1. Read out is unstable during counting, so stop counting before reading out. The counter is initialized to "0" during reset.

Port address	LR ₀	Reading count values
IP0C	0	The Lower 4-bits of HTC1 counter
	1	The upper 4-bits of HTC1 counter
IP0D	0	The Lower 4-bits of HTC2 counter
	1	The upper 4-bits of HTC2 counter

Table 2-3. Reading of count value

(3) 20-bit Counter Function

The HTC1 counter is connected to TC1 (12-bit Timer/Counter) and can operate as 20-bit counter when TC1 is set to the event counter mode. In this case, TC1 increments when HTC1 overflows. The TC1 input (T1) is connected to HTC1 and can only be used as an event counter when set to the event counter mode (linked to HTC1) or a timer when set to the timer mode.

When used as a 20-bit counter in the timer, event counter and frequency measurement mode described later, the HTC1 tends to overflow more often when applied frequencies are high and preset values are large; therefore, there may be counting errors. Consequently, it is necessary to set the applied frequency and preset value so that HTC1 overflows occur at the rate of no more than once per 8 instruction cycles.

2.2.4 Function of High Speed Timer/Counter

(1) Event counter mode

The counter increments for each rising edge of the external pin (HT1, HT2) input. The maximum applied frequency for HT1 and HT2 is f_c [Hz].

Example : Reading count values and Enable of Event Count mode

```
LD      A, #0100B      ; Sets the Event count mode of HTC2
OUT     A, %OP18
:
LD      A, #0000B      ; Stops the Event counter mode of HTC2
OUT     A, %OP18
LD      HL, #50H       ; RAM [50H] ← Lower 4-bit by HTC2 register
IN      %IPOD, @HL
INC     L               ; RAM [51H] ← Upper 4-bit by HTC2 register
IN      %IPOD, @HL
```

(2) Timer mode (HTC1)

The counter increments at the rising edges of internal pulses generated by the interval timer. Three different internal pulse rates can be selected using the command register. HTC1 is connected to TC1; therefore, optional high-resolution times can be obtained by loading the initial values into the HTC1 register (OP0C) or TC1 counter register (addresses F4-F6H of DMB0) and generating overflow interrupt of TC1.

Example : After setting preset value, sets the timer mode of HTC1 and the Event Counter mode of TC1.

```
LD      L, #0000B      ; LR0 ← 0
OUT     #5H, %OP0C     ; Sets "5" in Lower 4-bit of HTC1 register
LD      L, #0001B      ; LR0 ← 1
OUT     #0AH, %OP0C    ; Sets "A" in Upper 4-bit of HTC1 register
LD      A, #0100B      ; Sets the Event counter mode of TC1
OUT     A, %OP1C
LD      A, #1001B      ; Sets the Timer mode of HTC1
OUT     A, %OP17
:
:                       ; Counting
```

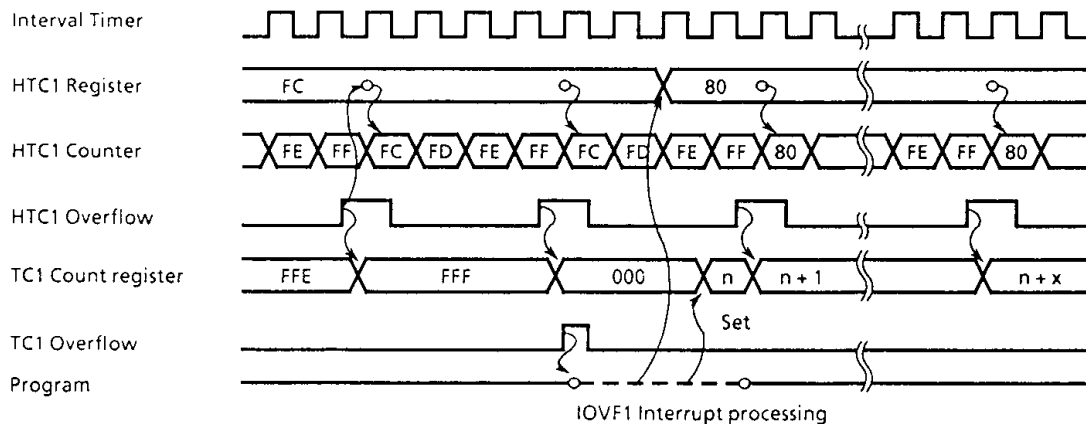

Figure 2-5. Timer mode

(3) Frequency measurement mode

The window gate width (from interval timer output fall to rise) interval specified by the command register and the rising edges of pulses applied to HT1 and HT2 are counted in this mode. The value of the window gate width setting is the same as the interval timer interrupt frequency; therefore, by enabling interval timer interrupt, an ITMR interrupt request can be generated when counting ends. Normally, the content of the HTC counter is read and initialized in the ITMR interrupt service routine in preparation for the next count.

Maximum input frequency of HT1, HT2 are f_c [Hz].

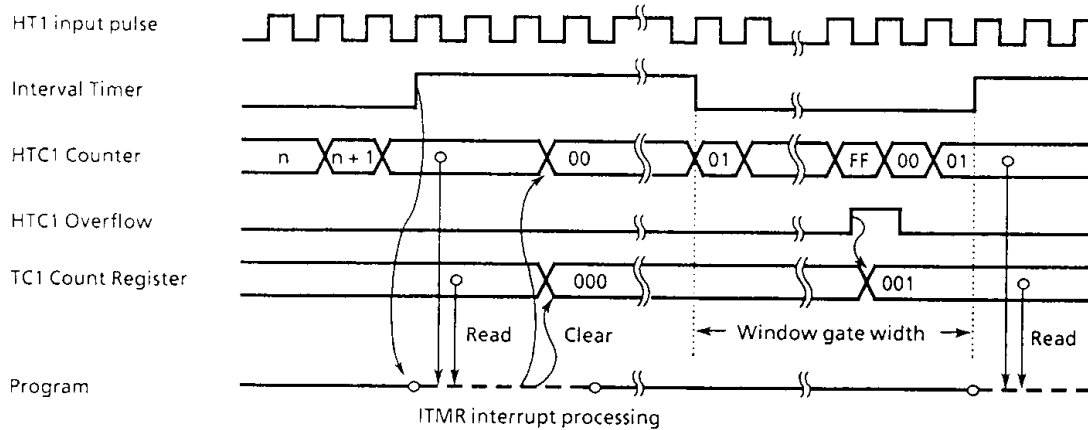

Figure 2-6. Frequency measurement mode

(4) Pulse output mode (HTC2)

Pulses of optional frequency are output to the $\overline{\text{PULSE}}$ pin in this mode. HTC2 counter overflows repeatedly set and clear the pulse output latch. The $\overline{\text{PULSE}}$ output pin is shared by the R42 output pin, in which case the R42 output latch should be set to "1". The pulse output latch is initialized to "0" and the $\overline{\text{PULSE}}$ output becomes "H" during reset.

A total of 765 different output frequencies (f_o) can be set using clock sources (3 can be selected with the command register) and preset values. One pulse output cycle ($1/f_o$) is expressed with the following formula.

$$\frac{1}{f_o} = 2 \times \frac{1}{(\text{Internal pulse rate})} \times \{256 - (\text{preset value})\}$$

(Preset value = 0 to 254)

Example: Calculating maximum output frequency (at $f_c = 4\text{MHz}$)

$$f_o \text{ max.} = \frac{1}{2} \times \frac{f_c}{2^3} \times \frac{1}{256 - 254} = \frac{4 \times 10^6}{32} = 125 \text{ [KHz]}$$

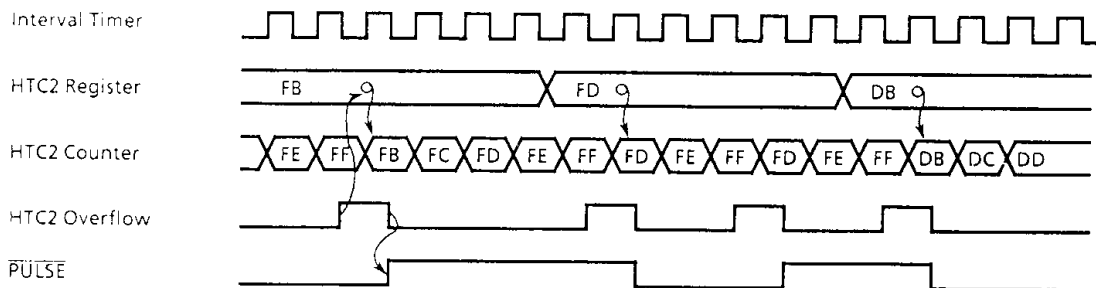

Figure 2-7. Pulse output mode

2.3 LCD Driver

The 47C620/820 have the circuit that directly drives the liquid crystal display (LCD) and its control circuit.

The 47C620/820 have the following connecting pins with LCD.

- ① Segment output port 32 pins (SEG31-SEG0)
- ② Common output port 4 pins (COM4-COM1)

In addition, VLC pin is provided as the drive power pin.

The devices that can be directly driven is selectable from LCD of the following drive methods.

- ① 1/4 Duty (1/3 Bias) LCD Max. 128 Segment (16 digits x 8 segments)
- ② 1/3 Duty (1/3 Bias) LCD Max. 96 Segment (12 digits x 8 segments)
- ③ 1/3 Duty (1/2 Bias) LCD Max. 96 Segment (12 digits x 8 segments)
- ④ 1/2 Duty (1/2 Bias) LCD Max. 64 Segment (8 digits x 8 segments)
- ⑤ Static LCD Max. 32 Segment (4 digits x 8 segments)

2.3.1 Configuration of LCD driver

Figure 2-8 shows the configuration of the LCD driver.

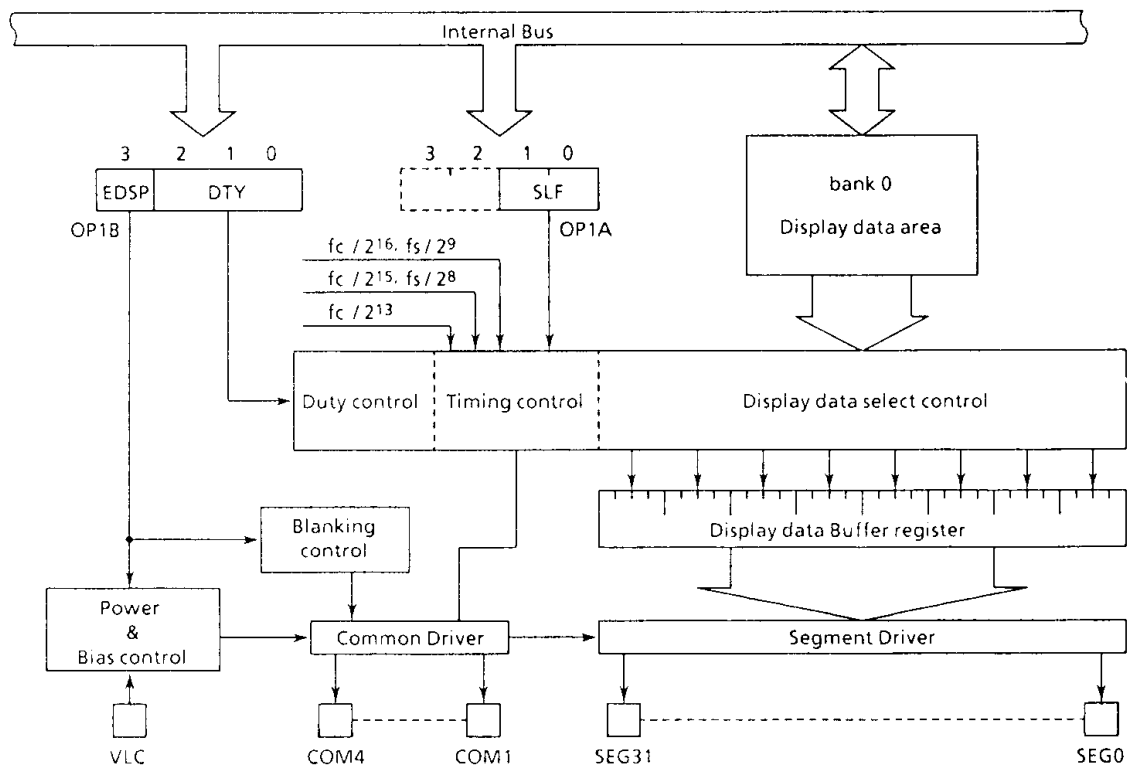
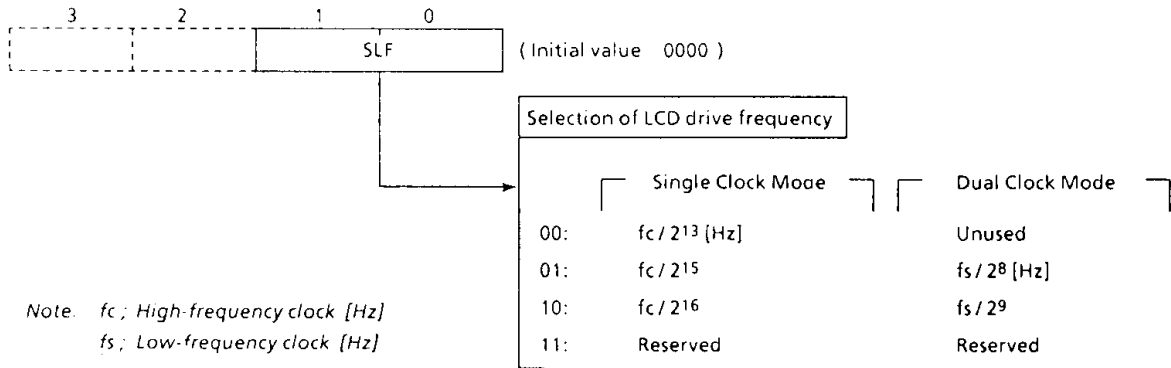

Figure 2-8. LCD Driver

2.3.2 Control of LCD driver circuit

The LCD driver is controlled by the command register 1,2 (OP1A, OP1B). Further, when the command register 1 is accessed, the most significant bit of the command register 2 must be set to "0" (Blanking).

LCD Driver control command register 1 (Port address OP1A)



LCD Driver control command register 2 (Port address OP1B)

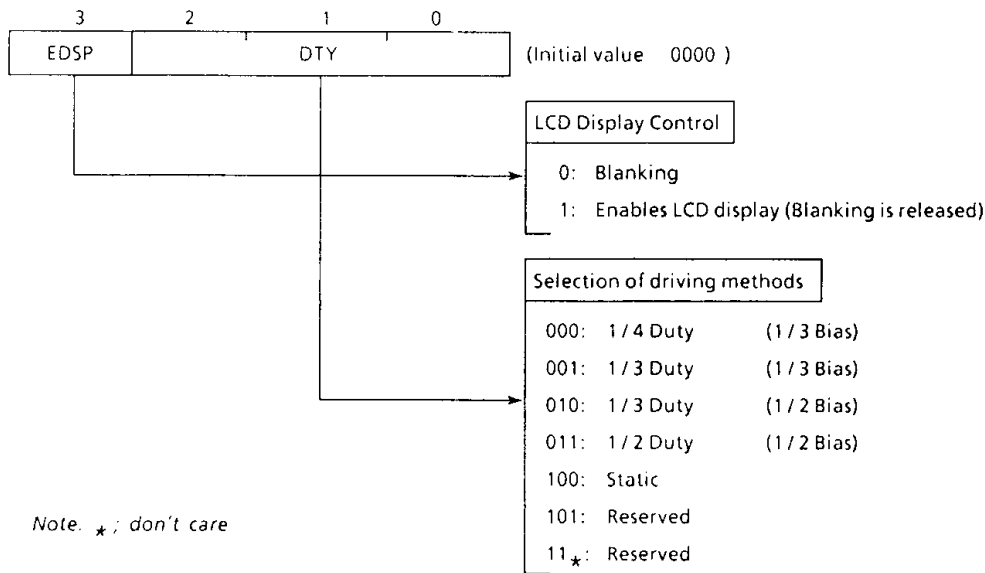

Figure 2-9. LCD Driver control Command Register

(1) Driving methods of LCD driver

Driving methods of LCD is selected 5 kind of DTY (bit 2-0 of command register 2). The drive method is initialized according to LCD used in the initial program.

Example of LCD and their drive waveform are shown in Figure 2-10.

① 1/4 Duty (1/3 Bias)

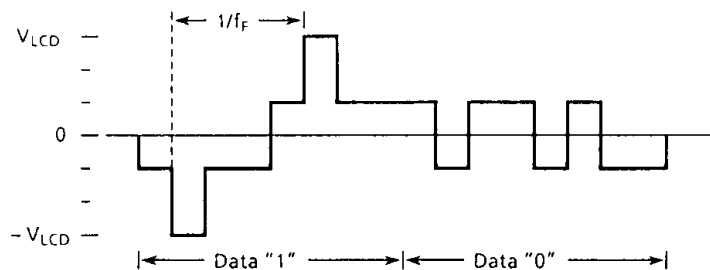

② 1/3 Duty (1/3 Bias)

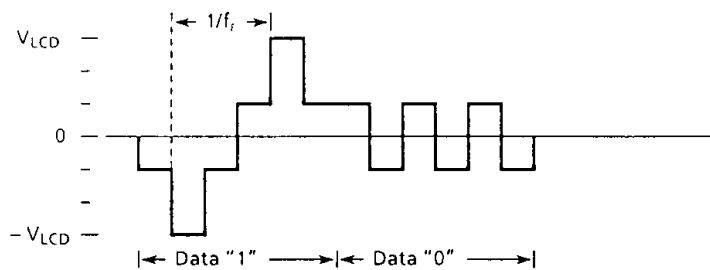

③ 1/3 Duty (1/2 Bias)

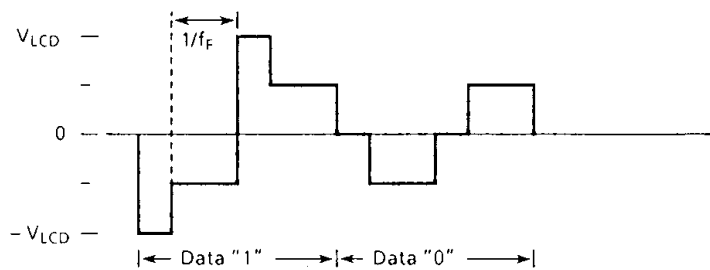

④ 1/2 Duty (1/2 Bias)

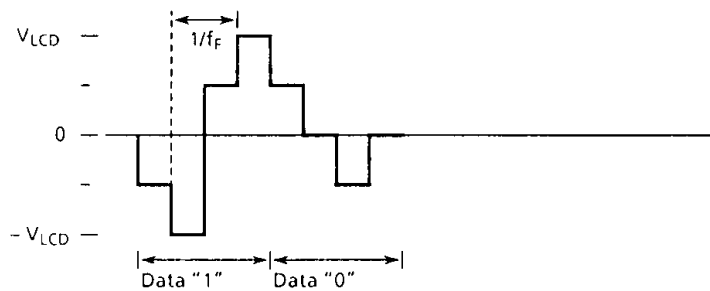

⑤ Static

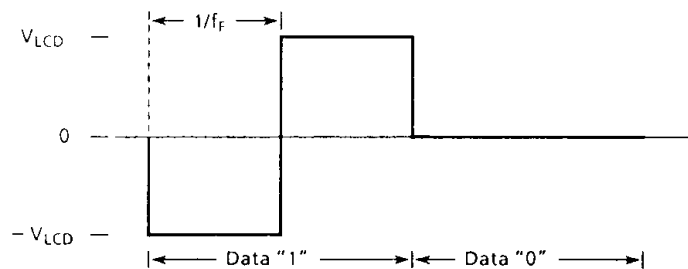

Figure 2-10. LCD drive waveform (COM-SEG pins)

(2) Frame frequency

Frame frequency (f_f) is set according to the drive method and base frequency as shown in the following table 2-4.

a. At the single clock mode

SLF	BASE FREQUENCY [Hz]	FRAME FREQUENCY [Hz]			
		1/4 DUTY	1/3 DUTY	1/2 DUTY	STATIC
10	$\frac{f_c}{2^{16}}$	$\frac{f_c}{2^{16}}$	$\frac{4}{3} \cdot \frac{f_c}{2^{16}}$	$\frac{4}{2} \cdot \frac{f_c}{2^{16}}$	$\frac{f_c}{2^{16}}$
	$f_c = 4\text{MHz}$	61	81	122	61
01	$\frac{f_c}{2^{15}}$	$\frac{f_c}{2^{15}}$	$\frac{4}{3} \cdot \frac{f_c}{2^{15}}$	$\frac{4}{2} \cdot \frac{f_c}{2^{15}}$	$\frac{f_c}{2^{15}}$
	$f_c = 4\text{MHz}$	122	163	244	122
00	$\frac{f_c}{2^{13}}$	$\frac{f_c}{2^{13}}$	$\frac{4}{3} \cdot \frac{f_c}{2^{13}}$	$\frac{4}{2} \cdot \frac{f_c}{2^{13}}$	$\frac{f_c}{2^{13}}$
	$f_c = 1\text{MHz}$	122	163	244	122

Note . f_c ; High-frequency clock [Hz]

b. At the dual clock mode

SLF	BASE FREQUENCY [Hz]	FRAME FREQUENCY [Hz]			
		1/4 DUTY	1/3 DUTY	1/2 DUTY	STATIC
10	$\frac{f_s}{2^9}$	$\frac{f_s}{2^9}$	$\frac{4}{3} \cdot \frac{f_s}{2^9}$	$\frac{4}{2} \cdot \frac{f_s}{2^9}$	$\frac{f_s}{2^9}$
	$f_s = 32\text{KHz}$	61	83	125	61
01	$\frac{f_s}{2^8}$	$\frac{f_s}{2^8}$	$\frac{4}{3} \cdot \frac{f_s}{2^8}$	$\frac{4}{2} \cdot \frac{f_s}{2^8}$	$\frac{f_s}{2^8}$
	$f_s = 32\text{KHz}$	125	167	250	125

Note . f_s ; Low-frequency clock [Hz]

Table 2-4. Setting of LCD Frame Frequency

(3) LCD drive voltage

The LCD drive voltage (V_{LCD}) is given by the difference in potential ($V_{DD}-V_{LC}$) between pins VDD and VLC. Therefore, when the CPU operating voltage and LCD drive voltage are the same, the VLC pin is connected to the VSS pin.

The LCDs light only when the difference in potential between the segment output and common output is $\pm V_{LCD}$, and turn off at all other times.

During reset, the power switch of the LCD driver is turned off automatically, shutting off the VLC voltage.

Both the segment output and common output become V_{DD} level at this time and the LCDs turn off.

The power switch is turned on to supply VLC voltage to the LCD driver by setting EDSP (bit 3 of the command register 2) to "1_B". After that, the power switch will not turn off even during blanking (setting EDSP to "01_B") and the VLC voltage continues to flow.

The power switch is turned off during hold operation low power consumption by turning off the LCD. When hold operation is released the status in effect immediately before the hold operation is reinstated.

2.3.3 LCD display operation

(1) Display data setting

Display data are stored to the display data area (Max 32 words) in the data memory (bank0).

The display data stored to the display data area (address 20-3FH) are read automatically and sent to the LCD driver by the hardware.

The LCD driver generates the segment signals and common signals in accordance with the display data and drive method. Therefore, display patterns can be changed by only overwriting the contents of the display data area with a program. The table look up instruction is mainly used for this overwriting.

Figure 2-11 shows the correspondence between the display data area and the SEG/COM pins. The LCD light when the display data is "1" and turn off when "0".

The number of segment which can be driven differs depending on the LCD drive method therefore, the number of display data area bits used to store the data also differs. Consequently, data memory not used to store display data and data memory for which the addresses are not connected to LCD can be used to store ordinary user's processing data.

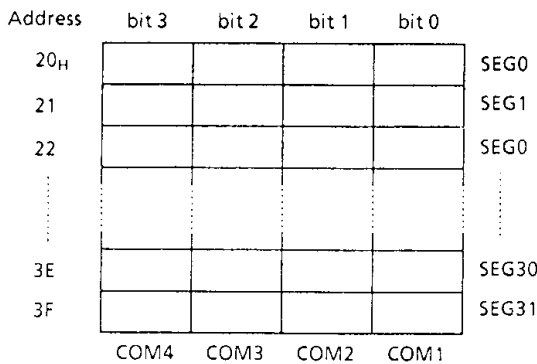

Figure 2-11. LCD Display Data Area (Bank 0)

Driving methods	bit 3	bit 2	bit 1	bit 0
1 / 4 Duty	COM4	COM3	COM2	COM1
1 / 3 Duty	-	COM3	COM2	COM1
1 / 2 Duty	-	-	COM2	COM1
Static	-	-	-	COM1

Note. - ; This bit is not used for display data.

Table 2-5. Driving Method and Bit for Display Data

(2) Blanking

Blanking is applied by setting EDSP to "0" and turns off the LCD by outputting the non light operation level to the COM pin.

The SEG pin continuously outputs the signal level in accordance with the display data and drive method.

With static drive, no voltage is applied between the COM and SEG pins when the LCD is turned off by data (display data cleared to "0"), but the COM pin output becomes constant at the $V_{LCD}/2$ level when turning off the LCD by blanking, so the COM and SEG pins are then driven by $V_{LCD}/2$.

2.3.4 Control method of LCD driver

(1) Initial Setting

Flow chart of initial setting are as shown in Figure 2-12.

Example : When operating the 47C820 with 1/4 duty LCD using a from frequency of $f_c/2^{16}$ [HZ].

```
LD      A, #0000B ; Sets the 1/4 duty drive
OUT     A, %OP1B
LD      A, #0010B ; Setting of base frequency
OUT     A, %OP1A
:
:         ; Setting of clear or initial value of
:         ; display area in the data memory
LD      A, #1000B ; Display enable
OUT     A, %OP1B
:
```

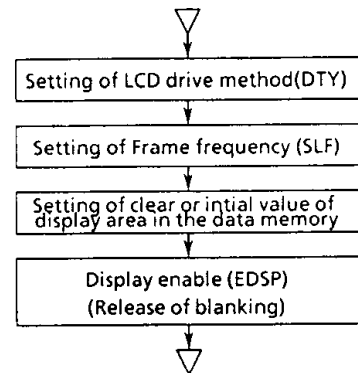

Figure 2-12. Intial setting of LCD driver

Example of numeric display data using the 1/4 duty LCD are given inTable 2-6. The COM pin and SEG pin connection method is as shown in Figure 2-13.

Num eric	Display	Display data		Num eric	Display	Display data	
		High order address	Low order address			High order address	Low order address
0	0.	1101	1111	5	5	1011	0101
1	1	0000	0110	6	6	1111	0101
2	2	1110	0011	7	7	0001	0111
3	3	1010	0111	8	8	1111	0111
4	4	0011	0110	9	9	1011	0111

Table 2-6. Example of display data (1/4 Duty LCD)

Further, example numeric display data (in the same way as in Table 2-6) using the 1/3 duty LCD are given in Table 2-7. The COM and SEG pin connection method is as shown in Figure 2-14 or 2-15.

Numeric	Display data			Numeric	Display data		
	High order address	Middle order address	Low order address		High order address	Middle order address	Low order address
0	**11	*101	*111	5	**01	*111	*010
1	**00	*000	*011	6	**11	*111	*010
2	**10	*111	*001	7	**01	*001	*011
3	**00	*111	*011	8	**11	*111	*011
4	**01	*101	*011	9	**01	*111	*011

Note. * ; don't care

Table 2-7. Example of display data (1/3 Duty LCD)

(2) Example of LCD drive output

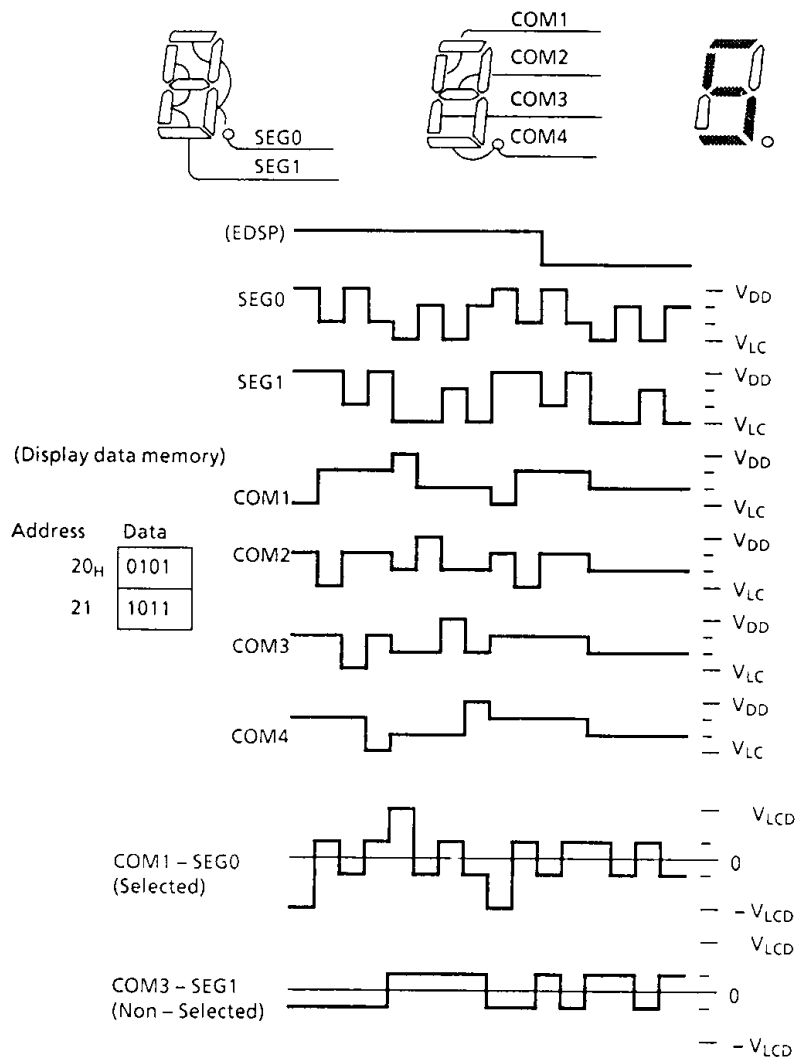

Figure 2-13. 1/4 Duty (1/3 Bias) Drive

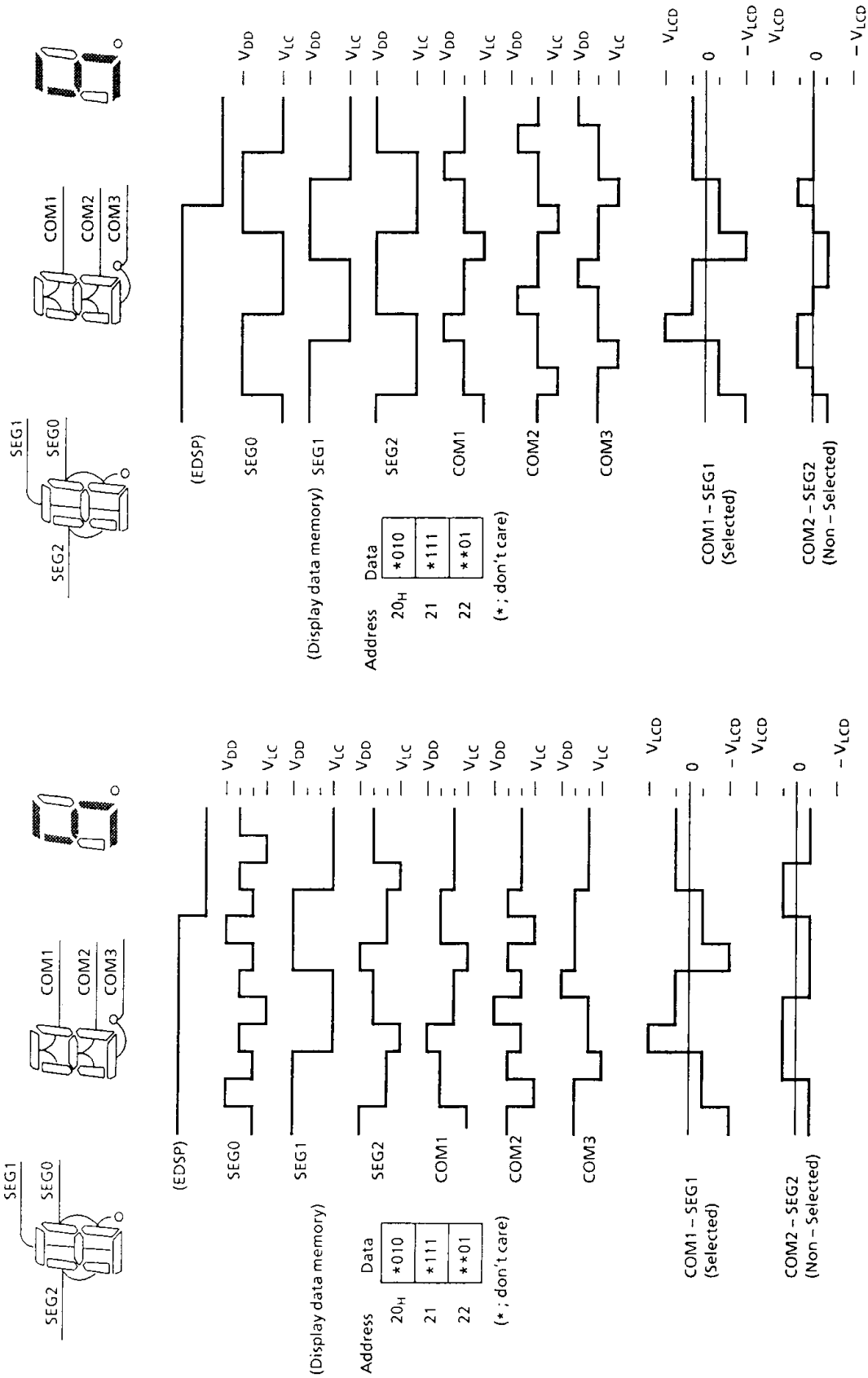

Figure 2-15. 1/3 Duty (1/2 Bias) Drive

Figure 2-14. 1/3 Duty (1/3 Bias) Drive

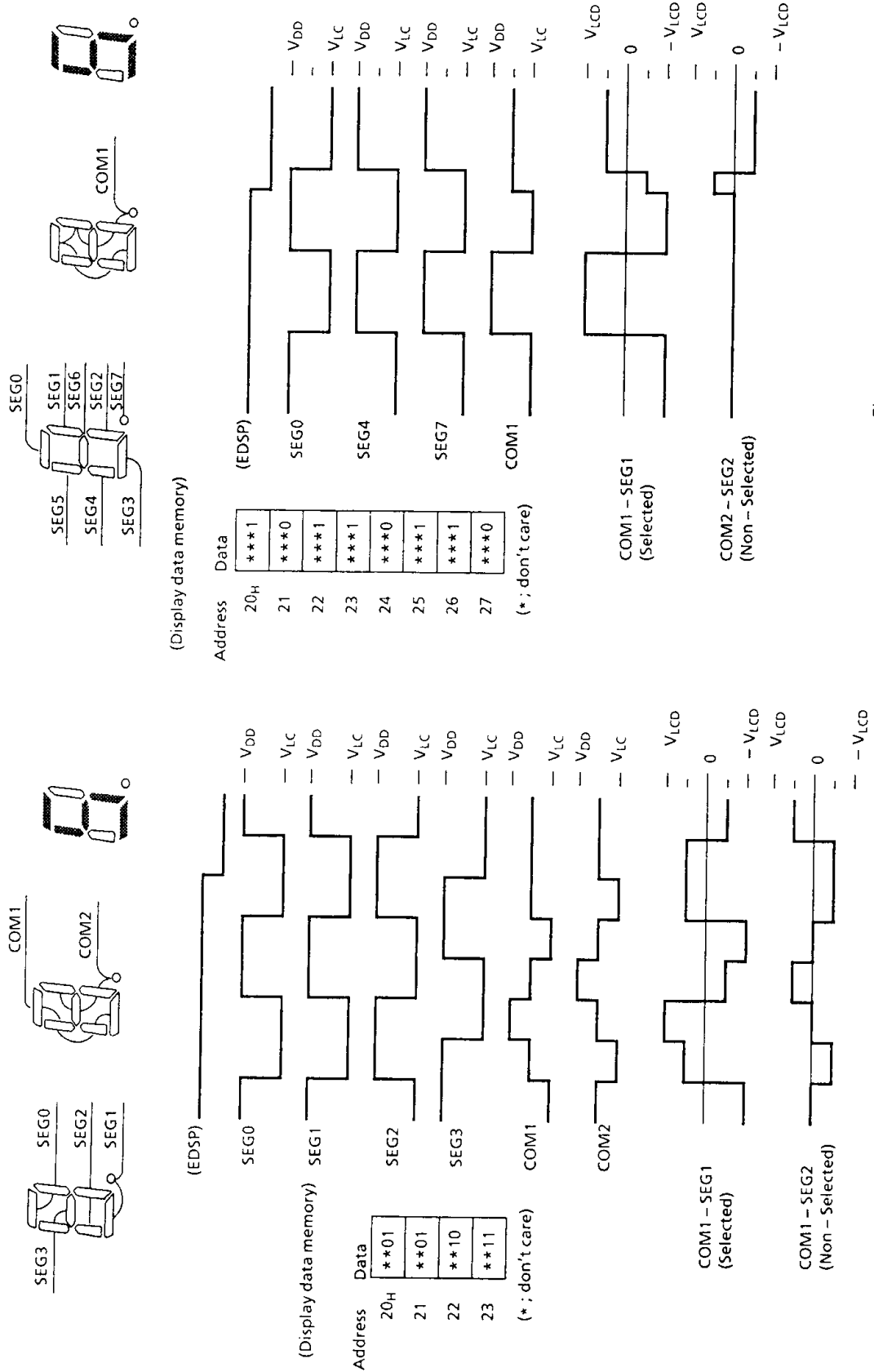

Figure 2-17. Static Drive

Figure 2-16. 1/2 Duty (1/2 Bias) Drive

ELECTRICAL CHARACTERISTICS

ABSOLUTE MAXIMUM RATINGS (V_{SS} = 0V)

PARAMETER	SYMBOL	PINS	RATINGS	UNIT
Supply Voltage	V _{DD}		- 0.3 to 7	V
Supply Voltage (LCD drive)	V _{LC}		- 0.3 to V _{DD} + 0.3	V
Input Voltage	V _{IN}		- 0.3 to V _{DD} + 0.3	V
Output Voltage	V _{OUT1}	Except sink open drain pin	- 0.3 to V _{DD} + 0.3	V
	V _{OUT2}	Sink open drain pin	- 0.3 to 10	
Output Current (Per 1 pin)	I _{OUT1}	Ports P1, P2	15	mA
	I _{OUT2}	Ports R4 to R9	3.2	
Output Current (Total)	ΣI _{OUT1}	Ports P1, P2	60	mA
Power Dissipation [T _{opr} = 70°C]	PD		600	mW
Soldering Temperature (time)	T _{slid}		260 (10sec)	°C
Storage Temperature	T _{stg}		- 55 to 125	°C
Operating Temperature	T _{opr}		- 40 to 70	°C

RECOMMENDED OPERATING CONDITIONS (V_{SS} = 0V, T_{opr} = - 40 to 70°C)

PARAMETER	SYMBOL	PINS	CONDITIONS	Min.	Max.	UNIT
Supply Voltage	V _{DD}		In the Normal mode	4.5	6.0	V
			In the SLOW mode	2.7		
			In the HOLD mode	2.0		
Input High Voltage	V _{IH1}	Except Hysteresis Input	V _{DD} ≥ 4.5V	V _{DD} × 0.7	V _{DD}	V
	V _{IH2}	Hysteresis Input		V _{DD} × 0.75		
	V _{IH3}		V _{DD} < 4.5V	V _{DD} × 0.9		
Input Low Voltage	V _{IL1}	Except Hysteresis Input	V _{DD} ≥ 4.5V	0	V _{DD} × 0.3	V
	V _{IL2}	Hysteresis Input			V _{DD} × 0.25	
	V _{IL3}		V _{DD} < 4.5V		V _{DD} × 0.1	
Clock Frequency	f _c	XIN, XOUT		0.4	6.0	MHz
	f _s	XTIN, XTOUT		30.0	34.0	KHz

Note. Input Voltage V_{IH3}, V_{IL3} : in the SLOW and HOLD mode.

D.C. CHARACTERISTICS

(V_{SS} = 0V, T_{opr} = -40 to 70°C)

PARAMETER	SYMBOL	PINS	CONDITIONS	Min.	Typ.	Max.	UNIT
Hysteresis Voltage	V _{HS}	Hysteresis Input		—	0.7	—	V
Input Current	I _{IN1}	Port K0, TEST, RESET, HOLD	V _{DD} = 5.5V,	—	—	± 2	μA
	I _{IN2}	Open drain R port	V _{IN} = 5.5V / 0V				
Input Low Current	I _{IL}	Push-pull R port	V _{DD} = 5.5V, V _{IN} = 0.4V	—	—	-2	mA
Input Registance	R _{IN1}	Port K0 with pull-up/pull-down		30	70	150	KΩ
	R _{IN2}	RESET		100	220	450	
Output Leakage Current	I _{LO}	Open drain ports P, R	V _{DD} = 5.5V, V _{OUT} = 5.5V	—	—	2	μA
Output High Voltage	V _{OH}	Push-pull R port	V _{DD} = 4.5V, I _{OH} = -200μA	2.4	—	—	V
Output Low Voltage	V _{OL2}	Except XOUT XTOUT and ports P1, P2	V _{DD} = 4.5V, I _{OL} = 1.6mA	—	—	0.4	V
Output Low Current	I _{OL1}	Ports P1, P2	V _{DD} = 4.5V, V _{OL} = 1.0V	—	10	—	mA
Segment Output Registance	R _{OS}	SEG pin	V _{DD} = 5V, V _{DD} - V _{LC} = 3V	—	20	—	KΩ
Common Output Registance	R _{OC}	COM pin					
Segment/Common Output Registance	V _{O2/3}	SEG / COM pin					
	V _{O1/2}		3.8	4.0	4.2	V	
	V _{O1/3}		3.3	3.5	3.7		
Supply Current (in the Normal mode)	I _{DD}		V _{DD} = 5.5V, V _{LC} = V _{SS} f _c = 4MHz	—	3		6
Supply Current (in the SLOW mode)	I _{DDS}		V _{DD} = 3.0V, V _{LC} = V _{SS} f _s = 32.768KHz	—	30	—	μA
Supply Current (in the HOLD mode)	I _{DDH}		V _{DD} = 5.5V	—	0.5	10	μA

Note 1. Typ. values show those at T_{opr} = 25°C, V_{DD} = 5V.

Note 2. Input Current I_{IN1} ; The current through resistor is not included, when the input resistor (pull-up/pull-down) is contained.

Note 3. Output Resistance R_{OS}, R_{OC} ; Shows on-resistance at the level switching.

Note 4. V_{O2/3} ; Shows 2/3 level output voltage, when the 1/4 or 1/3 duty LCD is used.

V_{O1/2} ; Shows 1/2 level output voltage, when the 1/2 duty or static LCD is used.

V_{O1/3} ; Shows 1/3 level output voltage, when the 1/4 or 1/3 duty LCD is used.

Note 5. Supply Current I_{DD}, I_{DDH} ; V_{IN} = 5.3V/0.2V

The K0 port is open when the input resistor is contained.

The voltage applied to the R port is within the valid range.

Note 6. Supply Current I_{DDS} ; V_{IN} = 2.8V/0.2V. Only low frequency clock is only osillated (connecting XTIN, XTOUT).

A.C. CHARACTERISTICS

($V_{SS} = 0V$, $V_{DD} = 4.5$ to $6.0V$, $T_{opr} = -40$ to $70^{\circ}C$)

PARAMETER	SYMBOL	CONDITIONS	Min.	Typ.	Max.	UNIT
Instruction Cycle Time	t_{cy}	in the Normal mode	1.9	—	20	μs
		in the SLOW mode	235	—	267	μs
High Level Clock Pulse Width	t_{WCH}	For external clock operation	80	—	—	ns
Low Level Clock Pulse Width	t_{WCL}					
Shift data Hold Time	t_{SDH}		$0.5t_{cy} - 300$	—	—	ns
High Speed Timer/Counter input frequency	f_{HT}		—	—	fc	MHz

Note. Shift data Hold time :

External circuit for SCK pin and SO pin

Serial port (completion of transmission)

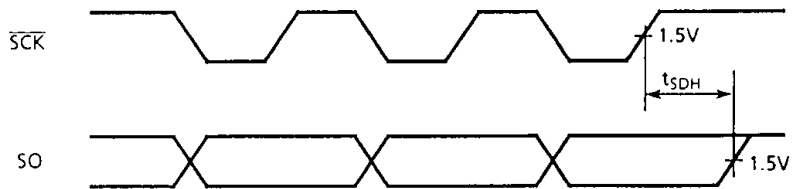
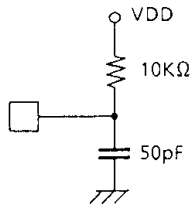

RECOMMENDED OSCILLATING CONDITIONS

($V_{SS} = 0V$, $V_{DD} = 4.5$ to $6.0V$, $T_{opr} = -40$ to $70^{\circ}C$)

(1) 6MHz

Ceramic Resonator

CSA6.00MGU (MURATA) $C_{XIN} = C_{XOUT} = 30pF$
 KBR-6.00MS (KYOCERA) $C_{XIN} = C_{XOUT} = 30pF$

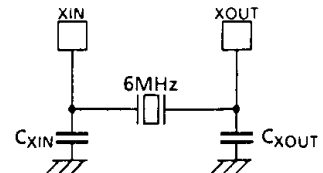

(2) 4MHz

Ceramic Resonator

CSA4.00MG (MURATA) $C_{XIN} = C_{XOUT} = 30pF$
 KBR-4.00MS (KYOCERA) $C_{XIN} = C_{XOUT} = 30pF$

Crystal Oscillator

204B-6F 4.0000 (TOYOCOM) $C_{XIN} = C_{XOUT} = 20pF$

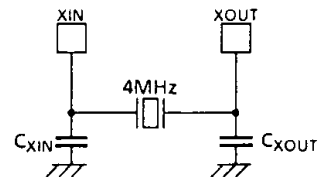

(3) 400KHz

Ceramic Resonator

CSB400B (MURATA) $C_{XIN} = C_{XOUT} = 220pF$,
 $R_{XOUT} = 6.8K\Omega$
 KBR-400B (KYOCERA) $C_{XIN} = C_{XOUT} = 100pF$, $R_{XOUT} = 10K\Omega$

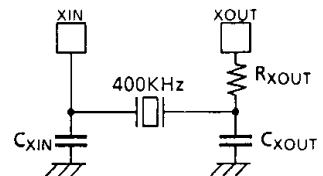

TYPICAL CHARACTERISTICS

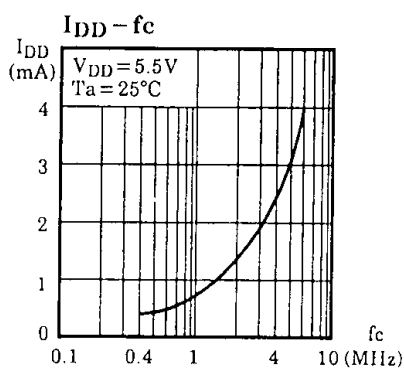
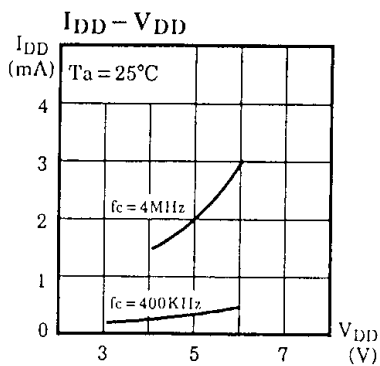
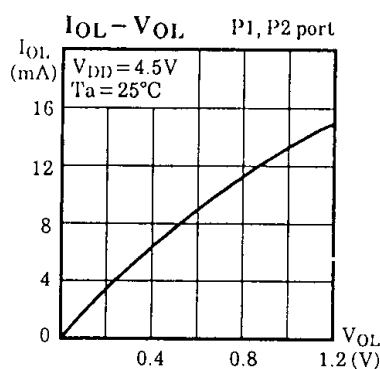
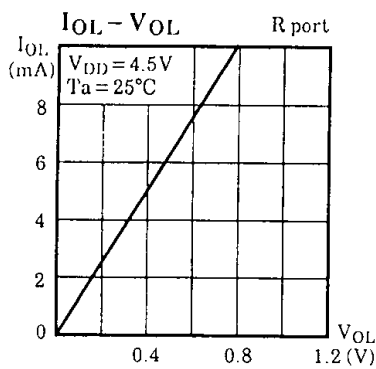
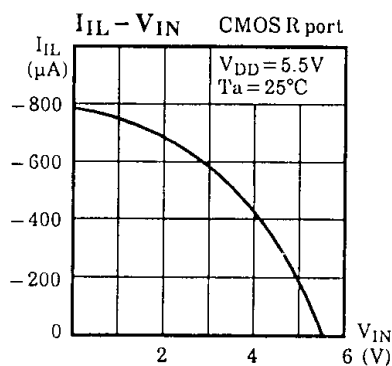
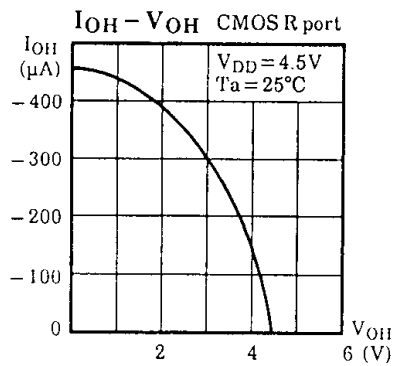
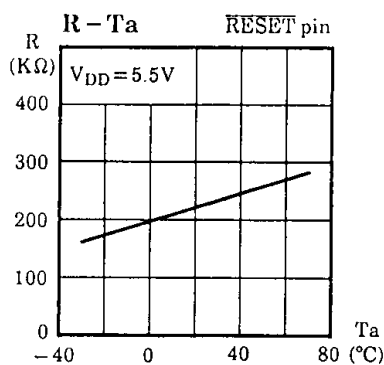
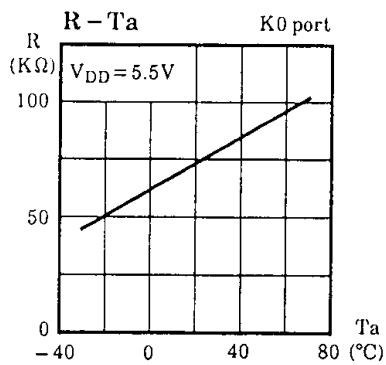

INPUT/OUTPUT CIRCUITRY

- (1) Control pins
The input/output circuitries of the 47C620/820 control pins are similar to those of the 47C660/860.
- (2) I/O Ports
The input/output circuitries of the 47C620/820 I/O ports are shown as belows, any one of the circuitries can be chosen by a code (GA to GF) as a mask option.

PORT	I/O	INPUT/OUTPUT CIRCUITRY and CODE			REMARKS
		GA, GD	GB, GE	GC, GF	
K0	Input				Pull-up/pull-down resistor $R_{IN} = 70K\Omega$ (typ.) $R = 1K\Omega$ (typ.)
P1 P2	Output				Sink open drain output Initial "Hi-Z" High current $I_{OL} = 10mA$ (typ.)
R40 R41	I/O				Sink open drain output Initial "Hi-Z" (Hysteresis) = Input (HTC) $R = 1K\Omega$ (typ.)
R42 R43 R7	I/O				Sink open drain output Initial "Hi-Z" $R = 1K\Omega$ (typ.)
R6 R5	I/O	GA, GB, GC Initial "Hi-Z" 	GD, GE, GF Initial "High" 	Sink open drain output or Push-pull output $R = 1K\Omega$ (typ.)	
					Sink open drain output Initial "Hi-Z" Hysteresis input $R = 1K\Omega$ (typ.)
R8 R9	I/O				Sink open drain output Initial "Hi-Z" Hysteresis input $R = 1K\Omega$ (typ.)