



TM

5

SUSSEX SEMICONDUCTOR, INC.
Power Rectifier
Devices

Section 5

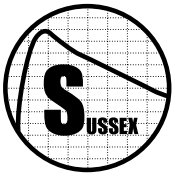

SUSSEX

SEMICONDUCTOR, INC.

POWER RECTIFIERS
6 AMP TO 70 AMP STANDARD,
FAST, ULTRA-FAST RECOVERY

12251 TOWNE LAKE DRIVE, FORT MYERS, FLORIDA, 33913 • TEL: (239) 768-6800 • FAX: (239) 768-6868

DO-4

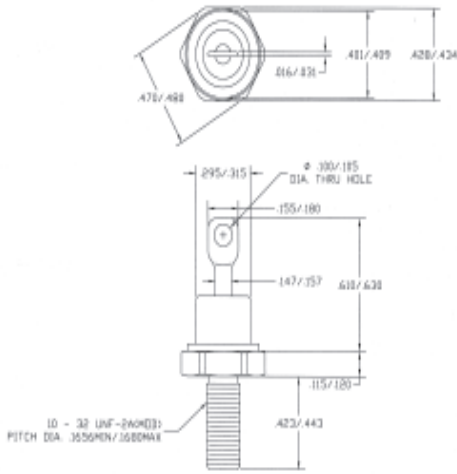

All Dimensions In Inches

DO-5

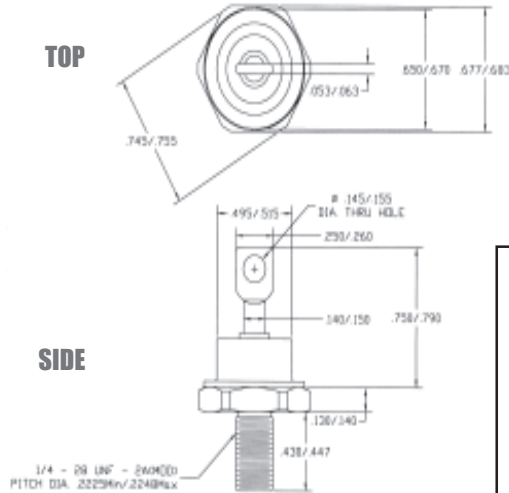

All Dimensions In Inches

GLASS PASSIVATED DO-4 AND DO-5 RECTIFIERS

100-1000 VOLTS

6 AMPS TO 70 AMPS

DO-4 AND DO-5 DEVICE SPECIFICATIONS

- ◆ Hermetically sealed glass to metal packaging
- ◆ For military and industrial use
- ◆ Standard Polarity cathode to base
- ◆ Copper terminals provide secure connections and excellent conductivity.
- ◆ Operating and storage temperature -65°C to +150°C

ELECTRICAL SCHEMATIC



TERMINAL

BASE

POWER RECTIFIER CUSTOM ORDERING SPECIFIER

CONTACT FACTORY FOR ELECTRICAL SPECIFICATIONS ON CUSTOM PARTS

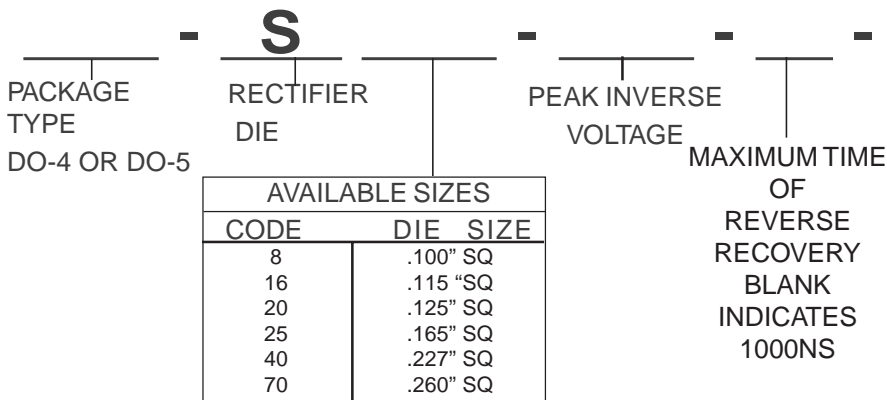

- ◆ BLANK- INDICATES STANDARD POLARITY CATHODE TO BASE
- ◆ R- INDICATES REVERSE POLARITY ANODE TO BASE

5

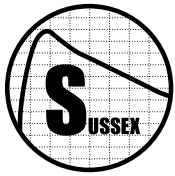

SUSSEX

SEMICONDUCTOR, INC.

POWER RECTIFIERS
6 AMP TO 70 AMP STANDARD,
FAST, ULTRA-FAST RECOVERY

12251 TOWNE LAKE DRIVE, FORT MYERS, FLORIDA, 33913 • TEL: (239) 768-6800 • FAX: (239) 768-6868

TABLE 16A - STANDARD RECOVERY POWER RECTIFIER DIE ELECTRICAL SPECIFICATIONS (NOTE 1)

JEDEC PART NUMBER (NOTE 2)	SUSSEX PART NUMBER	MAX. AVERAGE FORWARD RECTIFIED OUTPUT CURRENT AMPS	MAX. INSTANTANEOUS FORWARD VOLTAGE		MAX. LEAKAGE CURRENT (I _R)@ V _{DC}		PEAK FORWARD SURGE CURRENT (NOTE 3) AMPS	PEAK INVERSE VOLTAGE (PIV) VOLTS	MAX. RMS INPUT VOLTAGE V _{RMS} VOLTS
			FORWARD VOLTAGE TEST CURRENT (I _F) AMPS	PEAK FORWARD VOLTAGE @ I _F VOLTS	V _{DC} VOLTS	I _R μA			
1N1341A	DO4-S8-50	6.00	6.00	0.6	50	10.0	150	50	35
1N1341B	DO4-S8-50	6.00	20.00	1.2	50	10.0	150	50	35
1N1342A	DO4-S8-100	6.00	6.00	0.6	100	10.0	150	100	70
1N1342B	DO4-S8-100	6.00	20.00	1.2	100	10	150	100	70
1N1343A	DO4-S8-150	6.00	6.00	0.6	150	10	150	150	105
1N1343B	DO4-S8-150	6.0	6	1.2	150	10	150	150	105
1N1344A	DO4-S8-200	6.0	6	1.1	200	10	150	200	140
1N1344B	DO4-S8-200	6.0	20	1.2	200	10	150	200	140
1N1345A	DO4-S8-300	6.0	6	0.6	300	10	150	300	210
1N1345B	DO4-S8-300	6.0	6	1.1	300	10	150	300	210
1N1346A	DO4-S8-400	6.0	6	0.7	400	10	150	400	280
1N1346B	DO4-S8-400	6.0	20	1.2	400	10	150	400	280
1N1347A	DO4-S8-500	6	6	0.64	500	10	150	500	350
1N1347B	DO4-S8-500	6	6	1.2	500	10	150	500	350
1N1348A	DO4-S8-600	6	6	0.7	600	10	150	600	420
1N1348B	DO4-S8-600	6	20	1.2	600	10	150	600	420
1N3988	DO4-S8-800	6	20	1.2	800	10	150	800	560
1N3990	DO4-S8-1000	6.0	20.0	1.2	1000	10	150	1000	700
1N2276	DO5-S8-400	6.0	20.0	1.2	400	10	400	400	280
1N2277	DO5-S8-500	6.0	20.0	1.2	500	10	400	500	350
1N2278	DO5-S8-600	6.0	20.0	1.2	600	10	400	600	420
1N2279	DO5-S8-800	6	20	1.2	800	10	400	800	560
1N2280	DO5-S8-1000	6	20	1.2	1000	10	400	1000	700
1N2022	DO4-S16-250	10	25	0.6	250	10	200	250	35
1N2023	DO4-S16-300	10	25	0.6	300	10	200	300	35
1N2024	DO4-S16-350	10	25	0.6	350	10	200	350	35
1N2025	DO4-S16-400	10	25	0.6	400	10	200	400	35
1N2786	DO4-S16-200	10	10	0.6	200	10	200	200	35
1N2787	DO4-S16-400	10	10	0.6	400	10	200	400	35
1N2248	DO4-S16-100	10	10	0.6	100	10	200	100	35
1N2250	DO4-S16-200	10	10	0.6	200	10	200	200	35
1N2252	DO4-S16-300	10	10	0.6	300	10	200	300	35
1N2254	DO4-S16-400	10	10	0.6	400	10	200	400	35
1N2256	DO4-S16-500	10	10	0.6	500	10	200	500	35
1N2258	DO4-S16-600	10	10	0.6	600	10	200	600	35
1N2260	DO4-S16-800	10	10	0.6	800	10	200	800	35
1N3924	DO4-S16-1000	10	10	0.6	1000	10	200	1000	35
1N2262	DO4-S16-1000	10	10	0.6	1000	10	200	1000	35
1N1199	DO4-S16-50	12	40	1.8	50	10	240	50	35
1N1199A	DO4-S16-50	12	40	1.2	50	10	240	50	35
1N1199B	DO4-S16-52	12	40	1.2	50	10	250	50	35
1N1199C	DO4-S16-50	12	12	1.1	50	10	400	50	35
1N1200	DO4-S16-100	12	40	1.8	100	10	240	100	70
1N1200A	DO4-S16-100	12	40	1.2	100	10	240	100	70
1N1200B	DO4-S16-100	12	40	1.2	100	10	250	100	70
1N1200C	DO4-S16-100	12	12	1.1	100	10	400	100	70
1N1201	DO4-S16-150	12	20	1.4	150	10	240	150	105
1N1201B	DO4-S16-150	12	12	1.1	150	10	250	150	105
1N1201C	DO4-S16-150	12	12	1.1	150	10	400	150	105
1N1202B	DO4-S16-200	12	40	1.2	200	10	250	200	140
1N1202C	DO4-S16-200	12	40	1.8	200	10	400	200	140
1N1203	DO4-S16-200	12	12	1.1	200	10	100	200	140
1N1203B	DO4-S16-300	12	12	1.1	300	10	250	300	210
1N1204	DO4-S16-400	12	40	1.8	400	10	240	400	280
1N1204A	DO4-S16-400	12	40	1.2	400	10	240	400	280
1N1204B	DO4-S16-400	12	40	1.2	400	10	250	400	280
1N1205	DO4-S16-500	12	20	1.4	500	10	100	500	350
1N1205B	DO4-S16-500	12	12	1.1	500	10	250	500	350
1N1205C	DO4-S16-500	12	12	1.1	500	10	400	500	350
1N1206	DO4-S16-600	12	40	1.8	600	10	240	600	420
1N1206A	DO4-S16-600	12	40	1.2	600	10	240	600	420
1N1206B	DO4-S16-600	12	40	1.2	600	10	250	600	420

NOTES

NOTE 1: ♦ ELECTRICAL CHARACTERISTICS MEASURED AT A JUNCTION TEMPERATURE (T_J) OF 25°C UNLESS OTHERWISE STATED

NOTE 3: ♦ PEAK FORWARD SURGE CURRENT MEASURED FROM A SINGLE SINE-WAVE BEING SUPERIMPOSED ON A RATED LOAD (JEDEC METHOD)

NOTE 2: ♦ JEDEC PART NUMBERS REFER TO PACKAGED DEVICES. THE DIES INDICATED BY THESE NUMBERS, IF PROPERLY PACKAGED, WILL OPERATE WITH THE SAME PERFORMANCE

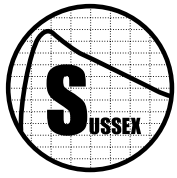

SUSSEX

SEMICONDUCTOR, INC.

POWER RECTIFIERS
6 AMP TO 70 AMP STANDARD,
FAST, ULTRA-FAST RECOVERY

12251 TOWNE LAKE DRIVE, FORT MYERS, FLORIDA, 33913 • TEL: (239) 768-6800 • FAX: (239) 768-6868

TABLE 15A - FAST AND ULTRA FAST RECOVERY POWER RECTIFIER DIE ELECTRICAL SPECIFICATIONS (NOTE 1)

JEDEC PART NUMBER (NOTE 2)	SUSSEX PART NUMBER	MAX. AVERAGE FORWARD RECTIFIED OUTPUT CURRENT $T_J=25^\circ\text{C}$ AMPS	MAX. INSTANTANEOUS FORWARD VOLTAGE		MAX. LEAKAGE CURRENT (I_R) @ V_{DC}		PEAK FORWARD SURGE CURRENT (NOTE 3) AMPS	PEAK INVERSE VOLTAGE (PIV) VOLTS	MAX. RMS INPUT VOLTAGE V_{RMS} VOLTS	TIME OF RECOVERY (T_{RR}) (NOTE 4) nanosec
			FORWARD VOLTAGE TEST CURRENT (I_F) AMPS	PEAK FORWARD VOLTAGE @ I_F VOLTS	V_{DC} VOLTS	I_R μA				
1N3879	DO4-S8-50-200	6.0	6.0	1.400	50	10	150	50	35	200
1N3880	DO4-S8-200-200	6.0	6.0	1.400	100	10	150	100	70	200
1N3881	DO4-S8-200-200	6.0	6.0	1.400	200	10	150	200	140	300
1N3881A	DO4-S8-200-300	6.0	6.0	0.900	200	10	150	200	140	300
1N3882	DO4-S8-300-200	6.0	6.0	1.500	300	10	150	300	210	200
1N3883	DO4-S8-400-200	6.0	6.0	1.400	400	10	150	400	280	200
1N3883A	DO4-S8-400-300	6.0	6.0	0.900	400	10	150	400	280	300
N/A	DO4-S8-600-200	6.0	6.0	1.500	600	10	150	600	420	200
1N3889	DO4-S16-50-200	12.0	12.0	1.400	50	10	250	50	35	200
1N3990	DO4-S16-100-200	12.0	12.0	1.400	100	10	100	100	70	200
1N3891	DO4-S16-200-200	12.0	12.0	1.400	200	10	250	200	140	200
1N3892	DO4-S16-300-200	12.0	12.0	1.400	300	10	250	300	210	200
1N3893	DO4-S16-400-200	12.0	12.0	1.400	400	10	250	400	280	200
N/A	DO4-S16-600-200	12.0	12.0	1.500	600	10	250	600	420	200
N/A	DO4-S16-800-200	12.0	12.0	1.500	800	10	240	800	560	200
N/A	DO4-S16-1000-300	12.0	12.0	1.500	1000	10	240	1000	700	300
N/A	DO4-S16-200-35	12.0	12.0	0.975	200	10	250	200	140	35
N/A	DO4-S16-400-50	12.0	12.0	0.975	400	10	250	400	280	50
N/A	DO4-S16-600-50	12.0	12.0	1.800	600	10	250	600	420	50
N/A	DO4-S16-800-50	12.0	12.0	1.800	800	10	240	800	560	50
N/A	DO4-S16-1000-50	12.0	12.0	2.000	1000	10	240	1000	700	50
1N3900	DO5-S20-100-200	20.0	20.0	1.400	100	20	400	100	70	200
1N3901	DO5-S20-200-200	20.0	20.0	1.400	200	20	400	200	140	200
1N3902	DO5-S20-300-200	20.0	20.0	1.400	300	20	400	300	210	200
1N3903	DO5-S20-400-200	20.0	20.0	1.400	400	20	400	400	280	200
N/A	DO5-S25-200-50	25.0	25.0	1.000	200	20	400	200	140	50
N/A	DO5-S25-400-50	25.0	25.0	1.000	400	20	400	400	280	50
N/A	DO5-S25-600-50	25.0	25.0	1.800	600	20	400	600	420	50
N/A	DO5-S25-800-75	25.0	25.0	1.800	800	20	400	800	560	75
N/A	DO5-S25-1000-75	25.0	25.0	2.000	1000	25	400	1000	700	75
N/A	DO5-S40-200-50	40.0	40.0	1.000	200	20	500	200	140	50
N/A	DO5-S40-600-50	40.0	40.0	1.000	600	20	500	600	420	50
N/A	DO5-S40-1000-50	40.0	40.0	2.000	1000	25	500	1000	700	50
N/A	DO5-S70-50-50	70.0	70.0	1.000	50	20	750	200	140	50
N/A	DO5-S70-100-50	70.0	70.0	1.000	100	20	750	400	280	50
N/A	DO5-S70-200-50	70.0	70.0	1.000	200	20	750	600	420	50
N/A	DO5-S70-800	70.0	70.0	1.600	800	25	750	800	560	50

5

NOTES

NOTE 1: ♦ ELECTRICAL CHARACTERISTICS MEASURED AT A JUNCTION TEMPERATURE (T_J) OF 25°C UNLESS OTHERWISE STATED

NOTE 2: ♦ JEDEC PART NUMBERS REFER TO PACKAGED DEVICES. THE DIES INDICATED BY THESE NUMBERS, IF PROPERLY PACKAGED, WILL

OPERATE WITH THE SAME PERFORMANCE

NOTE 3: ♦ PEAK FORWARD SURGE CURRENT MEASURED FROM A SINGLE SINE-WAVE BEING SUPERIMPOSED ON A RATED (JEDEC METHOD) LOAD

FIGURE 1B - TYPICAL FORWARD CHARACTERISTICS

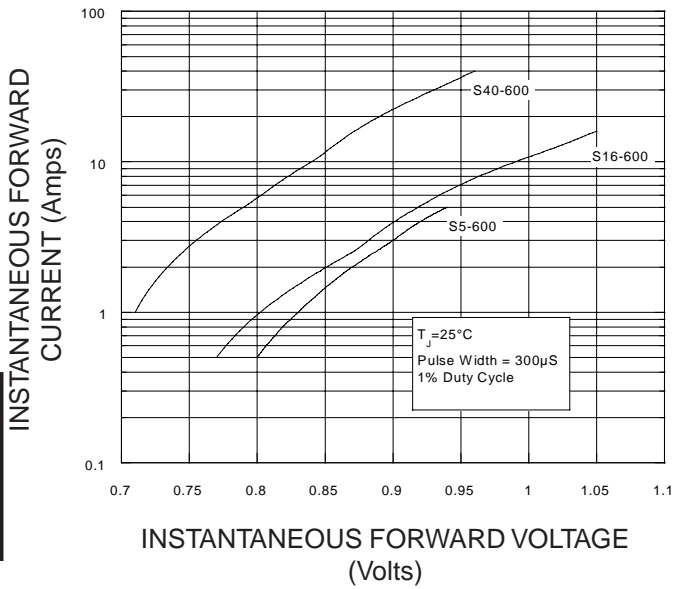

FIGURE 2B - TYPICAL REVERSE CHARACTERISTICS @25°C

