

Wall Industries, Inc.

CMLV12S24-150

Low Voltage DC-DC Chassis Mount Converter
10-36 Vdc Input
24Vdc Output at 6.25A
Half-Brick Package



Applications:

- For use in 12V and 24V battery applications.
- For use in Intermediate and Distributed Bus Architectures (IBA)
- Telecommunication equipment
- Network (LANs/WANs) Equipment
- Next generation low voltage, high current microprocessors and ICs

Features:

- Up to 87.5% Efficient
- Cost Efficient Solution
- Delivering 6.25A at Room Temperature with No Added Heat Sink with 400 LFM
- Fixed Switching Frequency
- High Reliability
- Output Short Circuit Protection
- Output Over Current Protection
- Optional Encapsulation for added Ruggedness
- Remote ON/OFF
- Remote Sense Compensation to 10% Vout
- Fast Transient Response
- 100% Burn In
- Soft Start

Description:

The CMLV12S24-150 is a high density, low input voltage, isolated converter on a chassis mount with a wide input voltage range. Low input voltage converters are uncommon in the industry and the CMLV12S24-150 offers the flexibility of operation with both 12V and 24V busses. This state-of-the-art converter's features include fast transient response, short circuit protection, over current protection, and many other features that are required for today's demanding applications.

Technical Specifications		Model No. CMLV12S24-150			
All specifications are based on 25°C, Nominal Input Voltage, and Maximum Output Current unless otherwise noted. We reserve the right to change specifications based on technological advances.					
SPECIFICATION	Related condition	Min	Nom	Max	Unit
Switching Frequency		-	400	-	kHz
INPUT (V_{in})					
Operating Voltage Range		10	12 / 24	36	Vdc
UVLO Turn On at		9.4	9.5	9.6	Vdc
UVLO Turn Off at		9.3	9.4	9.5	Vdc
Maximum Input Current	Low Line	-	17.7	-	A
No Load Input Current	No Load	-	0.15	-	A
Input Current under "Remote Off"		-	0.0064	-	A
Reflected Ripple Current		-	225	-	mA
Input Surge Voltage	100 mS			50	Vdc
EFFICIENCY		-	84.5	-	%
OUTPUT (V_o)					
Voltage Set Point	±RS shorted to ±Vo	23.76 -1%	24.0	24.24 +1%	Vdc %
Voltage Adjustment	Max Output limited to 150W	21.6 -10%	24.0	26.4 +10%	Vdc
Load Regulation	±RS shorted to ±Vo	-	0.1	0.2	%
Line Regulation	±RS shorted to ±Vo	-	0.1	0.2	%
Temperature Drift		-	0.2	-	% / °C
Remote Sense Compensation	Max Output limited to 150W	-		26.4 10%	Vdc %
Ripple	1µF Ceramic & 10µF Tantalum	-	360	-	mV _{pk-pk}
Spikes	1µF Ceramic & 10µF Tantalum	-	-	-	mV _{pk-pk}
Current		0	-	6.25	A
Current Limit	Power Limited-Dependent upon SENSE compensation and TRIM adjustment	-	8.2	-	A
Over Voltage Limit	Output Clamped	-	-	-	Vdc
DYNAMIC RESPONSE					
Load step / ΔV	1µF Ceramic & 10µF Tantalum				
Recovery Time	50% to 100% I _o , di/dt=1A/µS	-	200	-	mV
Recovery Time	Recovery to within 1% Nominal V _o	-	-	-	ms
Turn On Delay	From V _{in} (min) to V _{out} (nom)	-	-	-	ms
Turn On Overshoot	Full Load Resistive	-	0	-	%
Hold Up Time	From V _{in} (min) to V _{ULVO_Turn_Off}	0	-	-	mS
REMOTE ON/OFF					
Active High					
Remote ON – Active High	Min High (ON/OFF pin)	2.2	-	-	Vdc
Remote ON – Active Low	Max Low (ON/OFF pin)	N/A	-	-	Vdc
Remote OFF – Active High	Max Low (ON/OFF pin)	-	-	1.2	Vdc
Remote OFF – Active Low	Min High (ON/OFF pin)	N/A	-	-	Vdc
Remote ON/OFF pin Floating – Active High	Over Operating Voltage Range	2.5	-	5.0	Vdc
Remote ON/OFF pin Floating – Active Low	Over Operating Voltage Range	N/A	-	-	Vdc
I _{ON/OFF} Sink to pull low – Active Low or High	V _{ON/OFF} =0V, V _{in} =36V	-	-	0.38	mA
I _{ON/OFF} Source to drive high – Active High	V _{ON/OFF} =5V, V _{in} =36V	-	-	0.03	mA
I _{ON/OFF} Source to drive high – Active Low	V _{ON/OFF} =5V, V _{in} =36V	-	-	-	mA
Turn On Delay – Active High	ON/OFF (max Low) to V _{out} (min)	-	9	-	ms
Turn Off Delay – Active High	ON/OFF (0V) to V _{out} (min)	-	160	-	µS
ISOLATION					
Input-Output	1 minute	-	1500	-	Vdc
Input-Case	1 minute	-	500	-	Vdc
Output-Case	1 minute	-	500	-	Vdc
THERMAL					
Ambient	Max. Ambient limited by OTP	-40	25	OTP	°C
Over Temperature Protection (OTP)	Case Temperature Greater than	-	95	-	°C
Turn On (OTP)	Case Temperature Less than	-	85	-	°C
MTBF	Calculated Using Bellcore TR-332 Method 1 case 3		2,563,116		hours
MECHANICAL					See Figure 1

Figure 1: Mechanical Dimensions

Unit inches [mm]

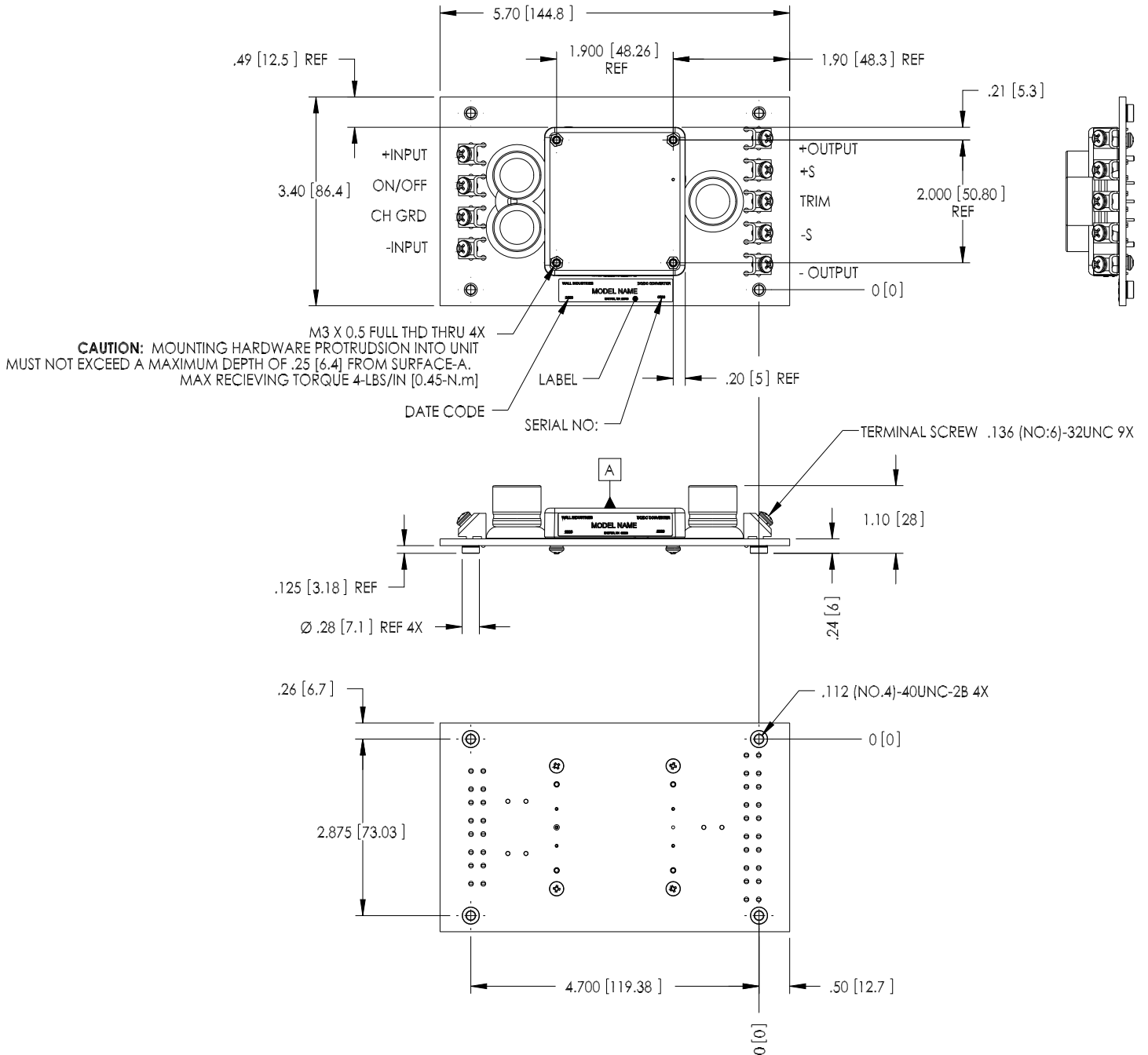

NOTES:

- PIN TO PIN TOLERANCE ± 0.01 [± 0.3], PIN DIAMETER TOLERANCE: ± 0.005 [± 0.13].
- CASE MATERIAL OF THE CONVERTER: $\varnothing .040$ [1.02] THICK, ALUMINUM ALLOY 3003-0, PER: QQA 250/2.
- UNLESS OTHERWISE SPECIFIED.

TO ORDER:

- UNIT COMES WITH EITHER 3M x 0.5 THREADED THRU INSERTS OR FOR $\varnothing .125$ THRU-HOLE FOR THE CHASSIS MOUNT BOARD ADD: "TH" SUFFIX TO MODEL PART NUMBER. EXAMPLE: CMLV12S24-150TH

DESIGN CONSIDERATIONS

Under Voltage Lock Out (UVLO)

The converter output is disabled until the input voltage exceeds the UVLO turn-on limit. The converter will remain ON until the input voltage falls below the UVLO turn-off limit.

Over Current Protection

The converter is protected from short circuit and over current conditions. During these fault conditions, the converter output will 'hiccup'. The converter output will recover once the short or over current fault is removed.

Over Temperature Protection (OTP)

The converter has internal thermal protection that will shut the converter OFF once the case temperature exceeds the OTP turn-off limit. The converter will resume operation when the case temperature has dropped below the OTP turn-on limit.

Output Filter

No additional output capacitor is needed for the power supply to operate. However, to reduce the ripple and noise on the output, additional capacitance may be added. A low ESR Ceramic capacitor may be added across the +Vo and -Vo pins to reduce the ripple and spike noise. Additional capacitance in the form of a tantalum or aluminum electrolytic may also be placed across these pins in order reduce ripple and improve the transient peak-to-peak voltage deviation.

Remote Sense

To improve the regulation at the load, route the connections from the -RS and the +RS pins to the -Vo and +Vo connections at the load. This will force the converter to regulate the voltage at the load and not at the pins of the converter (refer to Graph 6). If it is not desired to use the Remote Sense feature, the -RS and +RS pins may be left open or they may be shorted to the -Vo and +Vo pins respectively. Shorting the RS pins to the Vo pins will reduce the voltage drops through the converter pins.

Remote ON/OFF

The converter has the ability to be remotely turned ON or OFF. The LV series is Active-High. Active-High means that a logic high at the ON/OFF pin will enable the supply (Figure 2). With Active-High, if the ON/OFF pin is left floating, the supply will be enabled.

Figure 2: Active-High

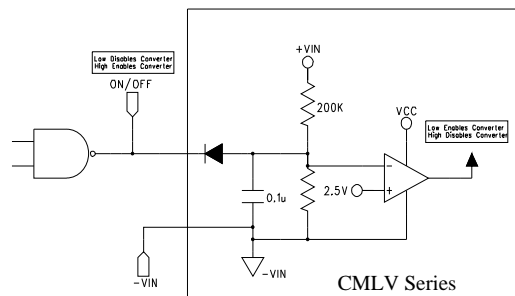

Output Voltage Trim: (24V, 26V, and 28V Models)

The output is adjustable $\pm 10\%$ of rated output voltage. To trim the output voltage up, place the trim resistor between the Trim and $-R_s$ pins (Figure 4). To trim the output voltage down, place the trim resistor between the Trim and $+R_s$ pins (Figure 3).

The value of the trim resistor with respect to the desired output voltage (V_o) can be derived from the following formulas or looked up on the trim table (Table 2).

$$R_{TH} = \frac{V_{ref}}{\frac{V_o - V_{ref}}{R_H} - \frac{V_{ref}}{R_L}} - R_{lim} \quad (\text{in Kohms})$$

$$R_{TL} = \frac{V_o - V_{ref}}{\frac{V_{ref}}{R_L} - \frac{V_o - V_{ref}}{R_H}} - R_{lim} \quad (\text{in Kohms})$$

Figure 3: Trim Down

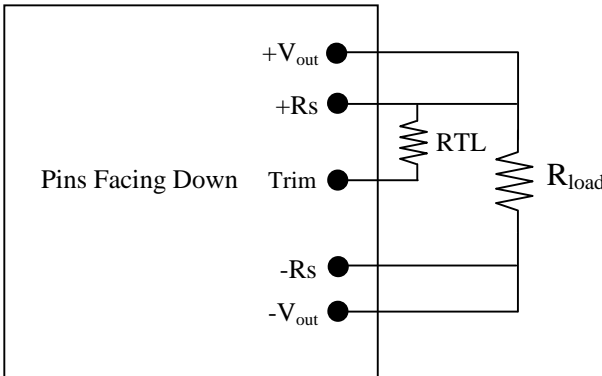

Figure 4: Trim Up

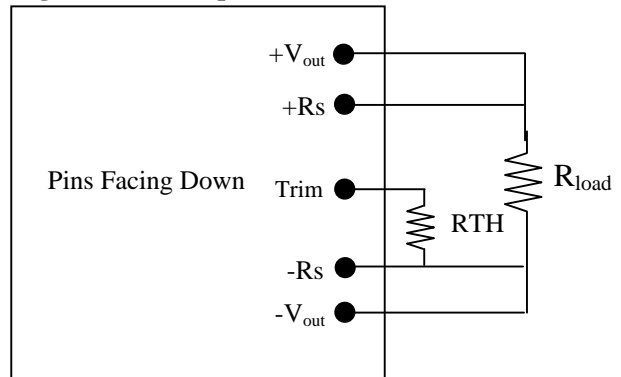

Table 2: Trim Equations for CMLV Series (24V, 26V, and 28V Models)

V _{nom}	V _{ref}	R _H	R _L	R _{lim}	R _{TH} to -R _s
24.000	2.495	22.00	2.55	8.25	R _{TL} to +R _s

Percent Trim	<u>Trim Low</u>		<u>Trim High</u>		All in Kohms
	V _o	R _{TL}	V _o	R _{TH}	
1%	23.760	1787.71	24.240	241.81	
2%	23.520	915.94	24.480	111.20	
3%	23.280	609.27	24.720	70.22	
4%	23.040	452.73	24.960	50.17	
5%	22.800	357.76	25.200	38.29	
6%	22.560	294.00	25.440	30.42	
7%	22.320	248.23	25.680	24.83	
8%	22.080	213.79	25.920	20.65	
9%	21.840	186.93	26.160	17.41	
10%	21.600	165.40	26.400	14.82	

Note that while decreasing the output voltage, the maximum output current still remains at 6.25A, and while increasing the output voltage, the output current is reduced to maintain a total output power at 150 W.

Paralleling Converters

The CMLV series converters may be paralleled both for redundancy and for higher output current. However, in order to do this, a high-current, low V_f schottky diode must be placed at the +Vo pin of each supply as shown in Figure 5. To improve sharing, tie the two TRIM pins together. The converters may be trimmed by adding a resistor value from Table 2 from each TRIM pin to $\pm RS$ pin, or alternatively, a single resistor of half the value of Table 2 from the common TRIM pins to the common $\pm RS$ pins.

Figure 5: Paralleling Converters

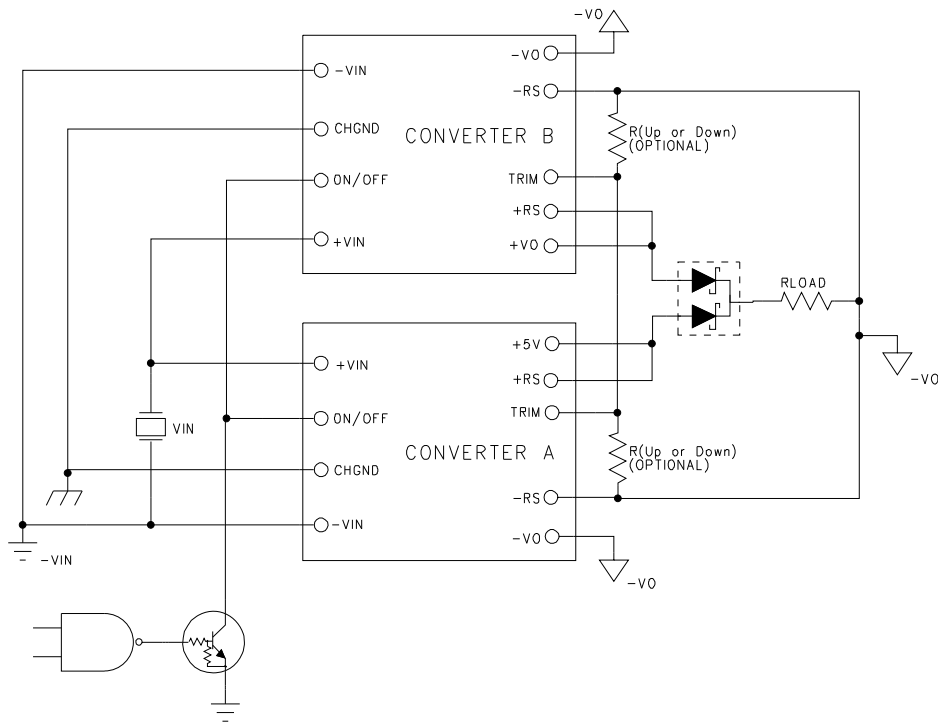

Graph 1: CMLV12S24-150 Efficiency vs. Output Current

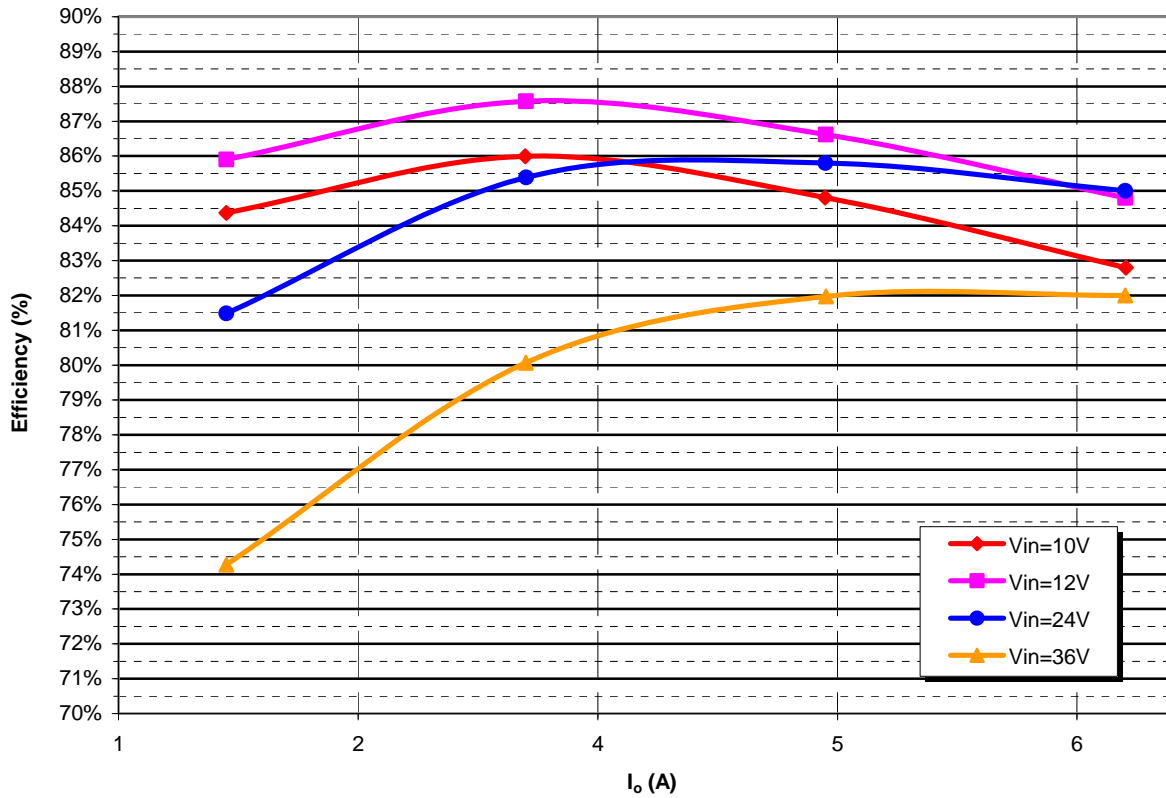

Graph 2: CMLV12S24-150 Max Ambient vs. Io (Vin=12V)

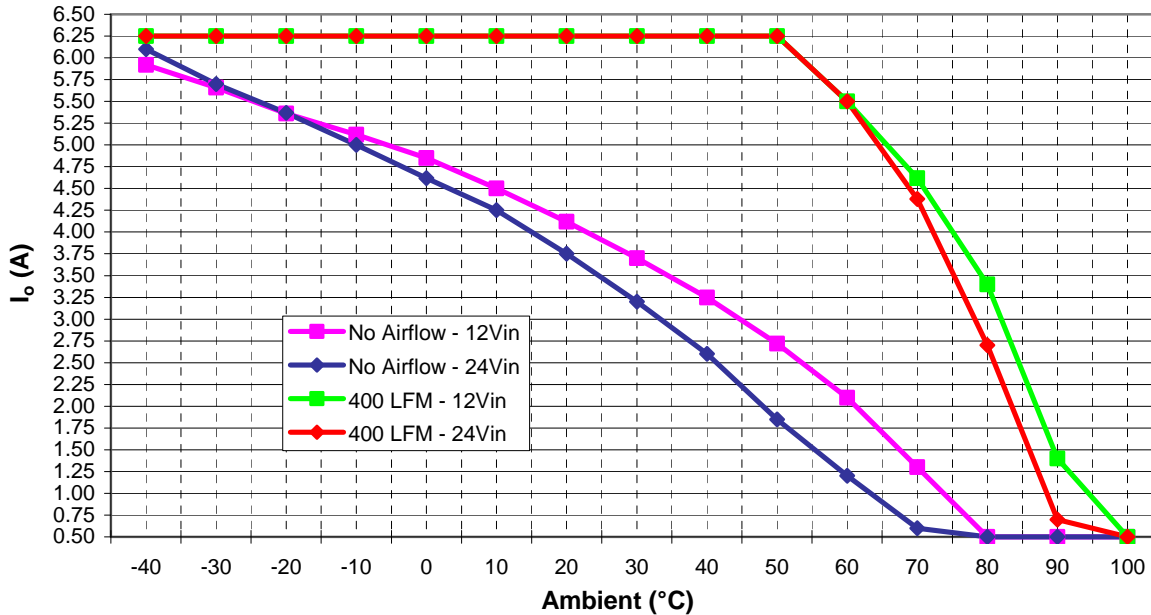

Graph 3: CMLV12S24-150 Power Dissipation vs. Input Voltage

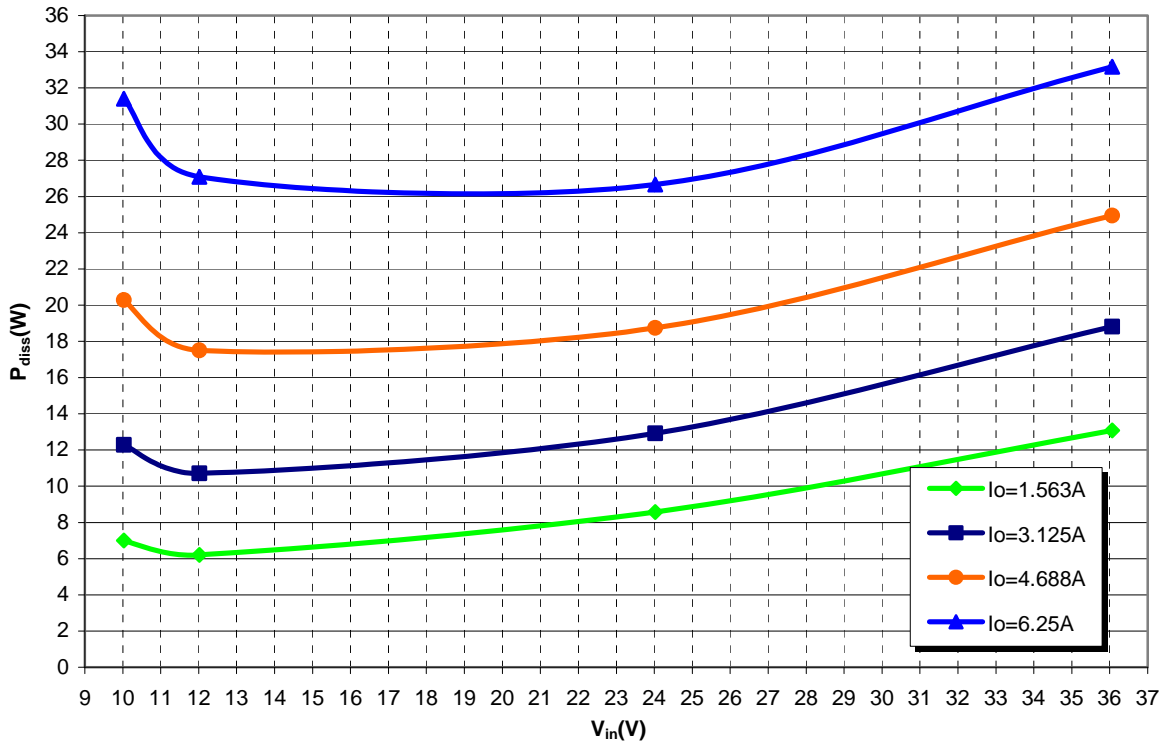

Graph 4: CMLV12S24-150 Input Current vs. Input Voltage

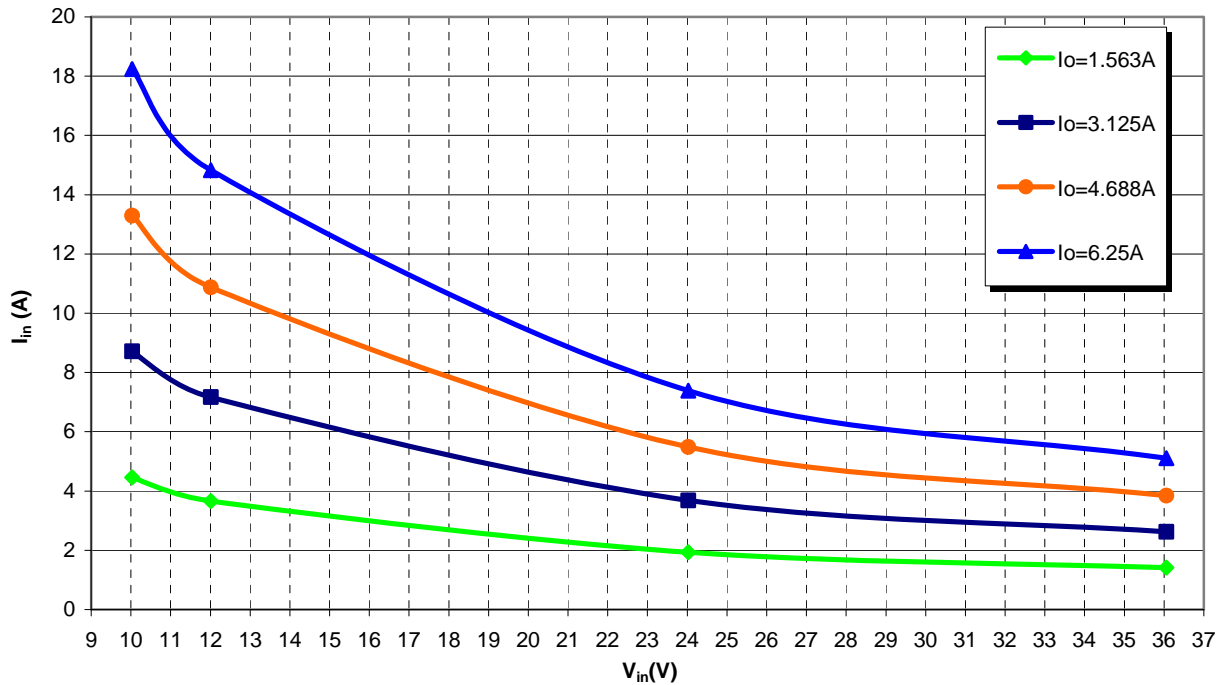

Graph 5: CMLV12S24-150 Load Regulation
(±RS Pins Open)

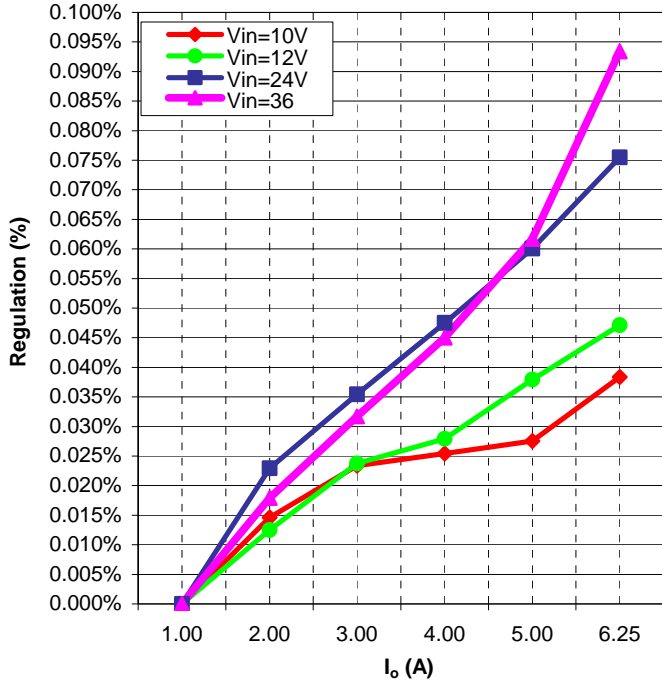

Graph 6: CMLV12S24-150 Load Regulation
(+RS to +V_o, -RS to -V_o)

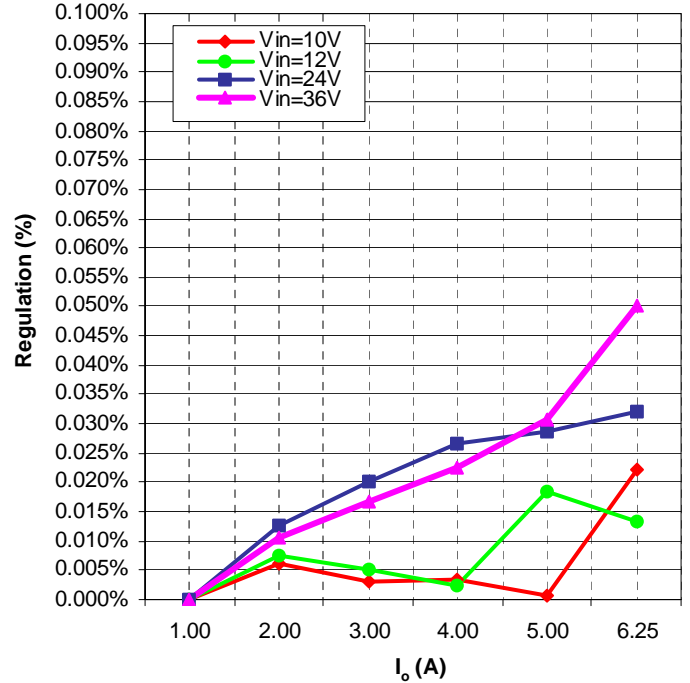

Graph 7: CMLV12S26-150 Line Regulation
(±RS Pins Open)

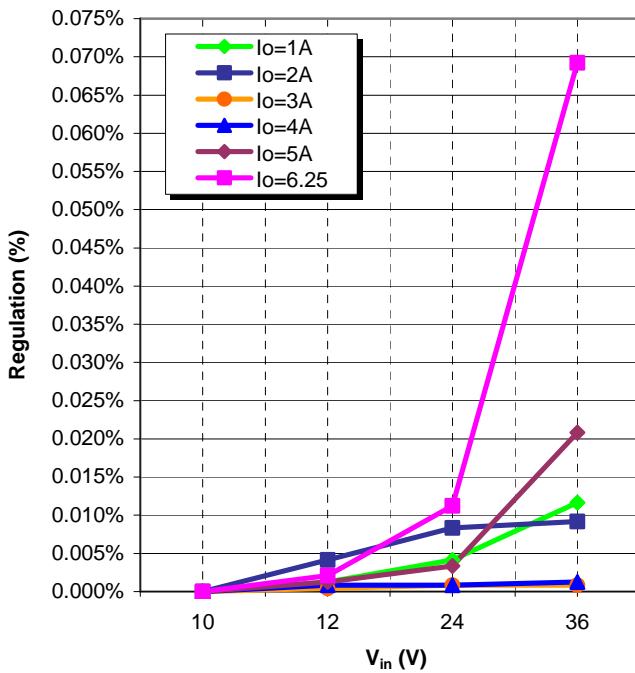

Graph 8: CMLV12S24-150 Line Regulation
(+RS to +V_o, -RS to -V_o)

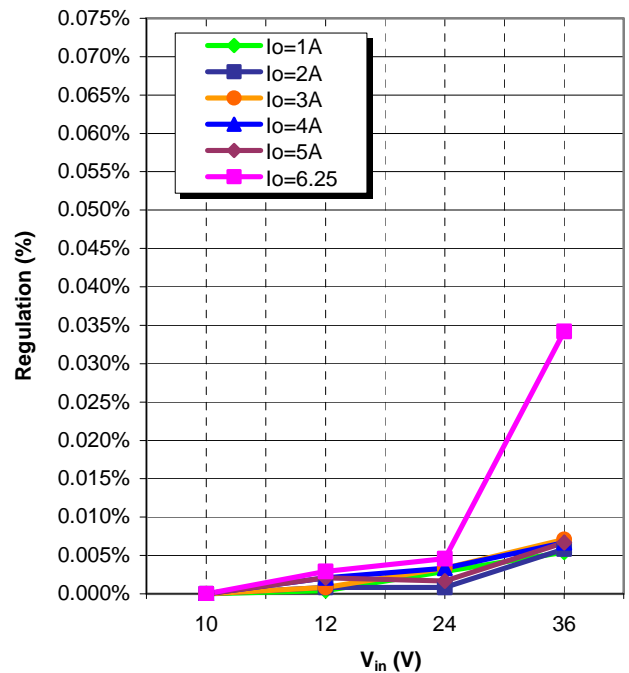

Note: Voltage measurements taken where the output pins are soldered into test board.

TEST SETUP:

The CMLV12S24-150 specifications are tested with the following configurations:

Regulation and Efficiency Setup

To ensure that accurate measurement are taken, the voltage measurements are taken directly at the terminal of the module. This minimizes errors due to contact and trace lengths between the load and the output of the supply. The following is a diagram of the test setup.

Figure 6: Regulation and Efficiency Probe Setup

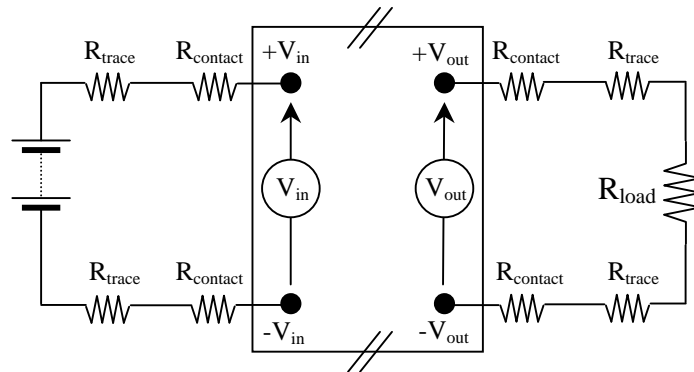

Output Ripple Voltage Setup

The module is tested with a 1 μ F ceramic capacitor in parallel with a 10 μ F tantalum capacitor across the output terminals.

Figure 7: Ripple Voltage Probe Setup

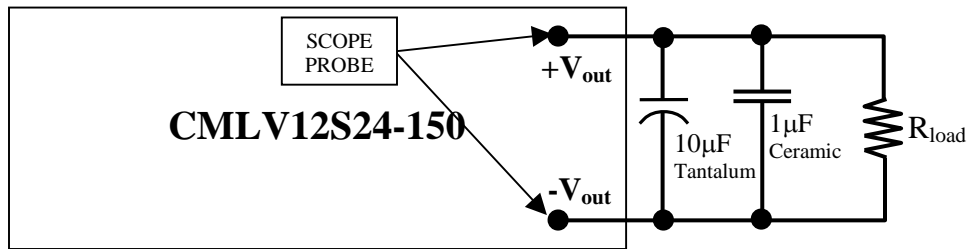

Input Reflected Ripple Current and Input Ripple Current Setup

The module is tested for input reflected ripple current (I_{rrc}) and input ripple current (I_{rc}). The input ripple voltage is also measured at the pins with the following input filter. If there is a need to reduce input ripple current/voltage then additional ceramic capacitors can be added to the input of the converter.

Figure 8: Ripple Current Setup

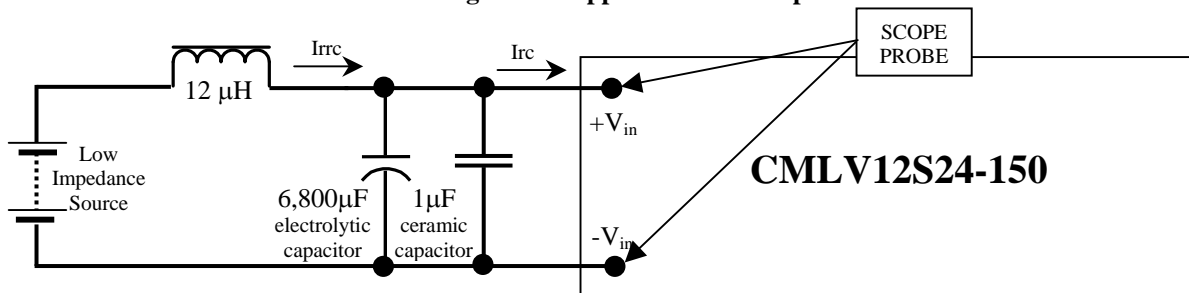

Converter Thermal Consideration

The converter is designed to operate without convective cooling if the derating curves are followed. The converter can operate at higher temperatures if airflow is applied. Airflow should be aligned lengthwise to the converter for optimum heat transfer. Contact Factory for derating curves.

Figure 9: Airflow Orientation

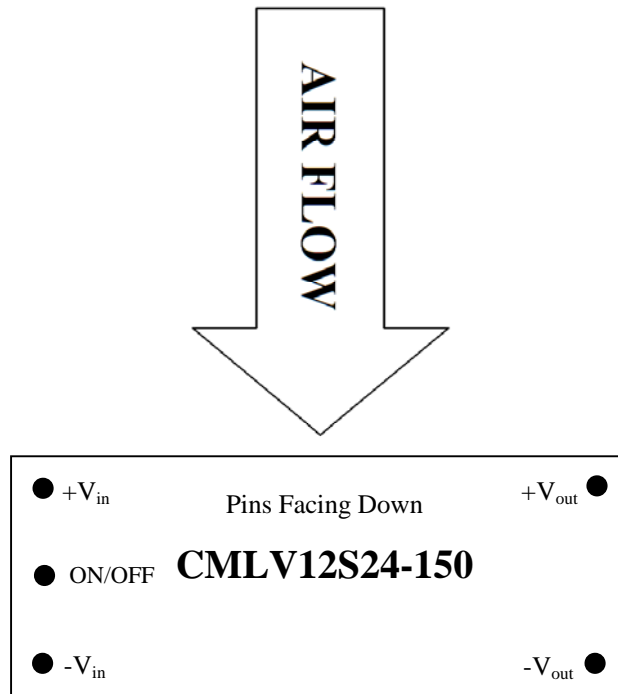

Ordering Information

Part Number Example:

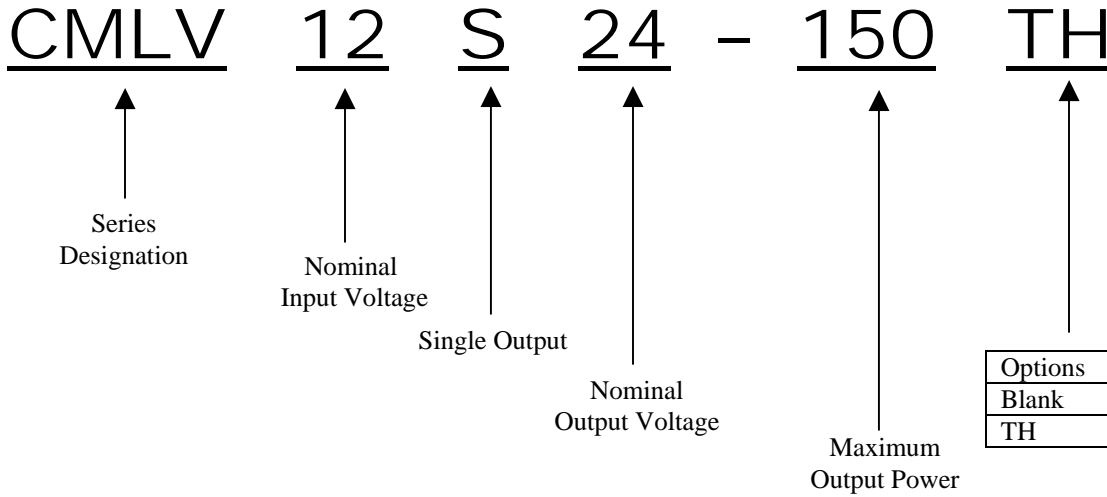

Options	
Blank	Threaded Hole
TH	Through Hole

Company Information:

Wall Industries, Inc. has created custom and modified units for over 40 years. Our in-house research and development engineers will provide a solution that exceeds your performance requirements on-time and on budget. Our ISO9001-2000 certification is just one example of our commitment to producing a high quality, well-documented product for our customers.

Our past projects demonstrate our commitment to you, our customer. Wall Industries, Inc. has a reputation for working closely with its customers to ensure each solution meets or exceeds form, fit and function requirements. We will continue to provide ongoing support for your project above and beyond the design and production phases. Give us a call today to discuss your future projects.

Contact **Wall Industries** for further information:

Phone: ☎(603)778-2300
Toll Free: ☎(888)587-9255
Fax: ☎(603)778-9797
E-mail: sales@wallindustries.com
Web: www.wallindustries.com
Address: 5 Watson Brook Rd.
 Exeter, NH 03833