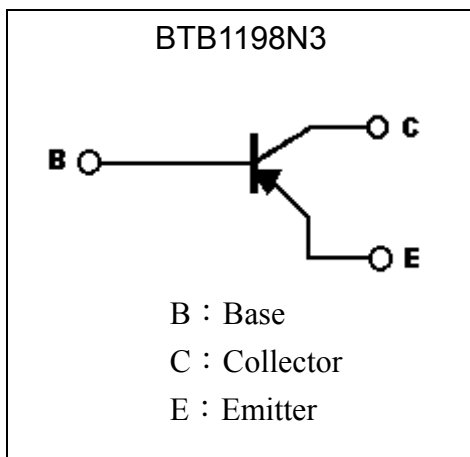
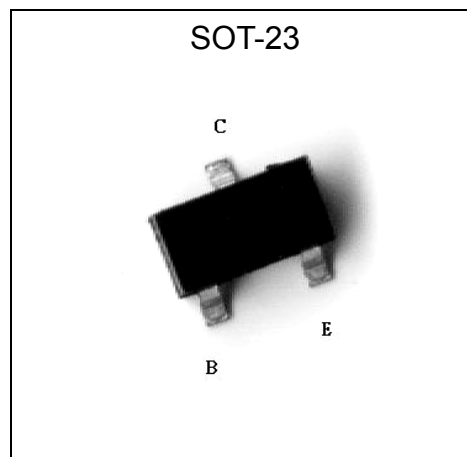

**PNP Epitaxial Planar Transistor**

# BTB1198N3

**Features**

- Low  $V_{CE(SAT)}$ ,  $V_{CE(SAT)} = -0.16V$  (Typ.) @  $I_C/I_B = -500mA/-50mA$
- High breakdown voltage,  $BV_{CEO} = -80V$
- Complementary to BTD1782N3
- Pb-free package

**Symbol**

**Outline**

**Absolute Maximum Ratings** ( $T_a = 25^\circ C$ )

Parameter	Symbol	Limits	Unit
Collector-Base Voltage	$V_{CBO}$	-80	V
Collector-Emitter Voltage	$V_{CEO}$	-80	V
Emitter-Base Voltage	$V_{EBO}$	-5	V
Collector Current	$I_C$	-0.5	A
Power Dissipation ( $T_A = 25^\circ C$ )	$P_D$	225 (Note)	mW
Power Dissipation ( $T_C = 25^\circ C$ )	$P_D$	560	mW
Thermal Resistance, Junction to Ambient	$R_{\theta JA}$	556 (Note)	$^\circ C/W$
Thermal Resistance, Junction to Case	$R_{\theta JC}$	223	$^\circ C/W$
Junction Temperature	$T_j$	150	$^\circ C$
Storage Temperature	$T_{stg}$	-55~+150	$^\circ C$

Note : Free air condition



## Characteristics (Ta=25°C)

Symbol	Min.	Typ.	Max.	Unit	Test Conditions
$BV_{CBO}$	-80	-	-	V	$I_C=-50\mu A$
$BV_{CEO}$	-80	-	-	V	$I_C=-2mA$
$BV_{EBO}$	-5	-	-	V	$I_E=-50\mu A$
$I_{CBO}$	-	-	-0.5	$\mu A$	$V_{CB}=-50V$
$I_{EBO}$	-	-	-0.5	$\mu A$	$V_{EB}=-4V$
$*V_{CE(sat)}$	-	-0.16	-0.5	V	$I_C=-500mA, I_B=-50mA$
$*h_{FE}$	120	-	390	-	$V_{CE}=-3V, I_C=-0.1A$
$f_T$	-	180	-	MHz	$V_{CE}=-10V, I_C=-50mA, f=100MHz$
$C_{ob}$	-	11	-	pF	$V_{CB}=-10V, f=1MHz$

\*Pulse Test: Pulse Width  $\leq 380\mu s$ , Duty Cycle  $\leq 2\%$

## Classification Of $h_{FE}$

Rank	Q	R
Range	120~270	180~390

## Ordering Information

Device	Package	Shipping	Marking
BTB1198N3	SOT-23 (Pb-free)	3000 pcs / Tape & Reel	AK

**Characteristic Curves**

Output Characteristics

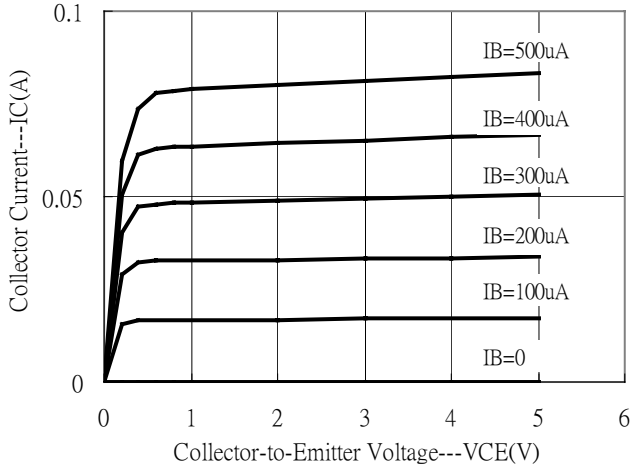

Output Characteristics

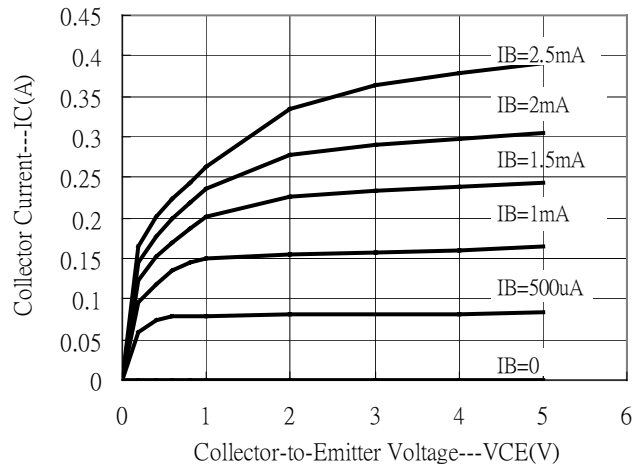

Output Characteristics

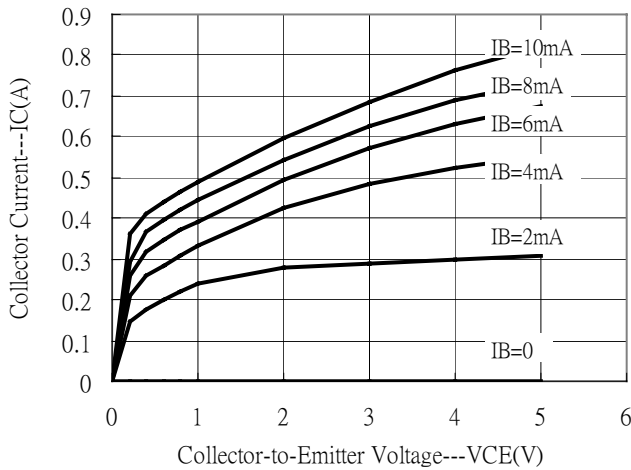

Output Characteristics

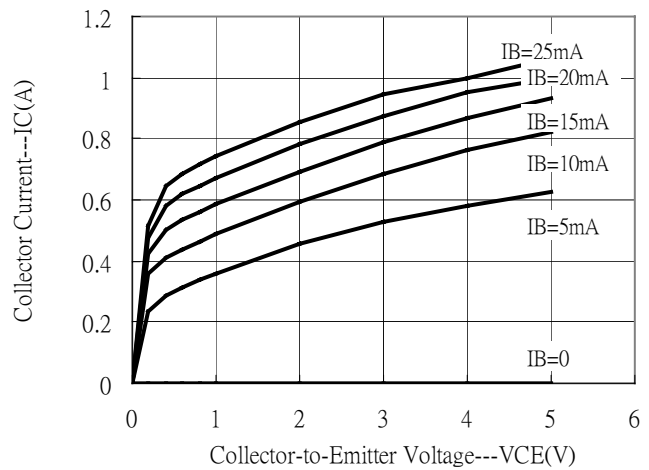

Current Gain vs Collector Current

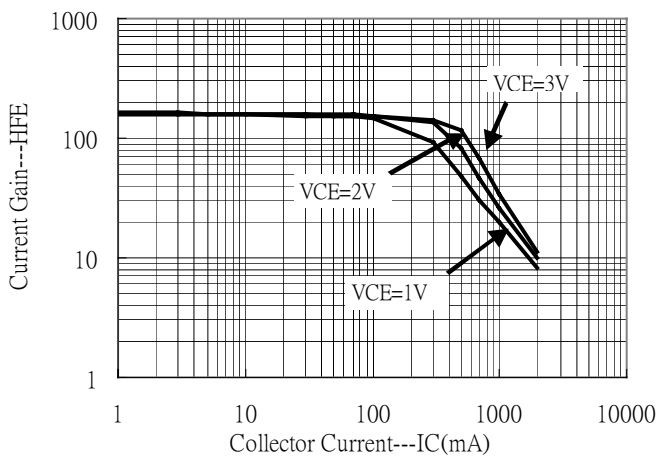

Saturation Voltage vs Collector Current

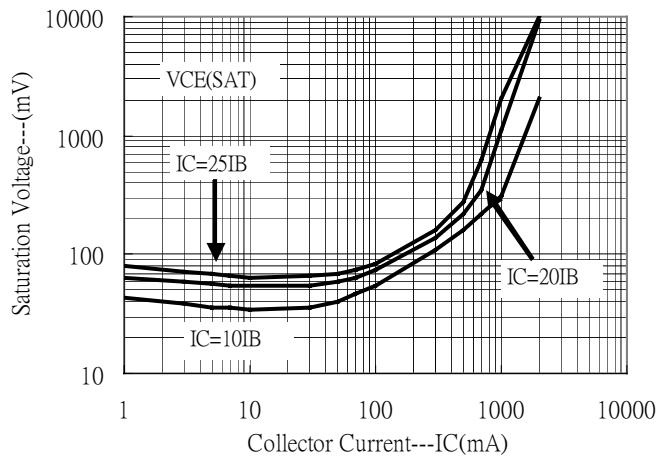



### Characteristic Curves(Cont.)

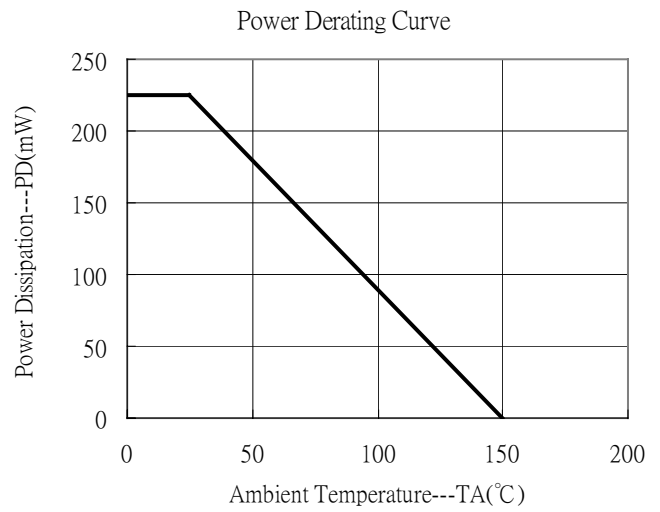
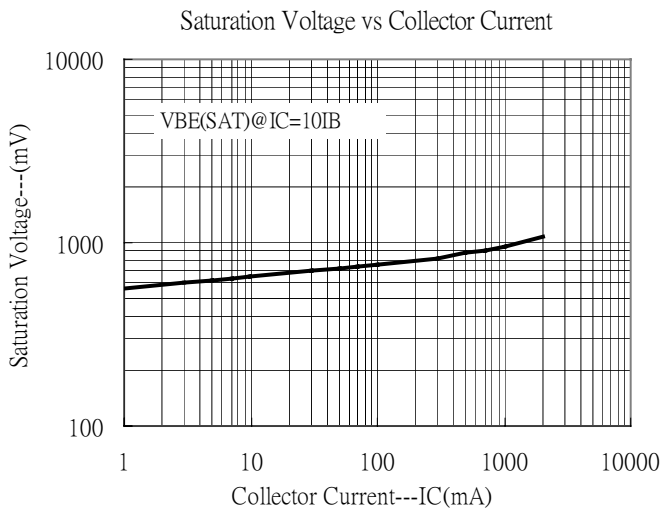

**Reel Dimension**

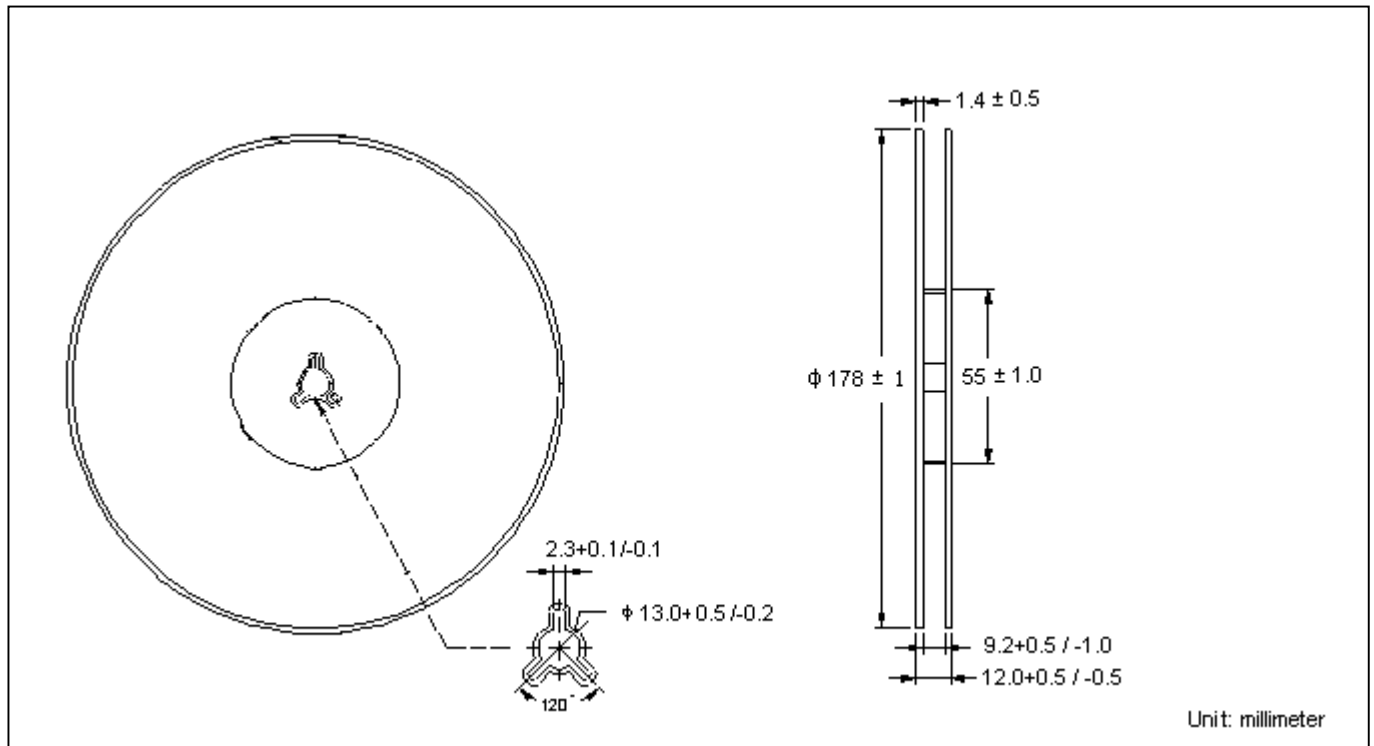

**Carrier Tape Dimension**

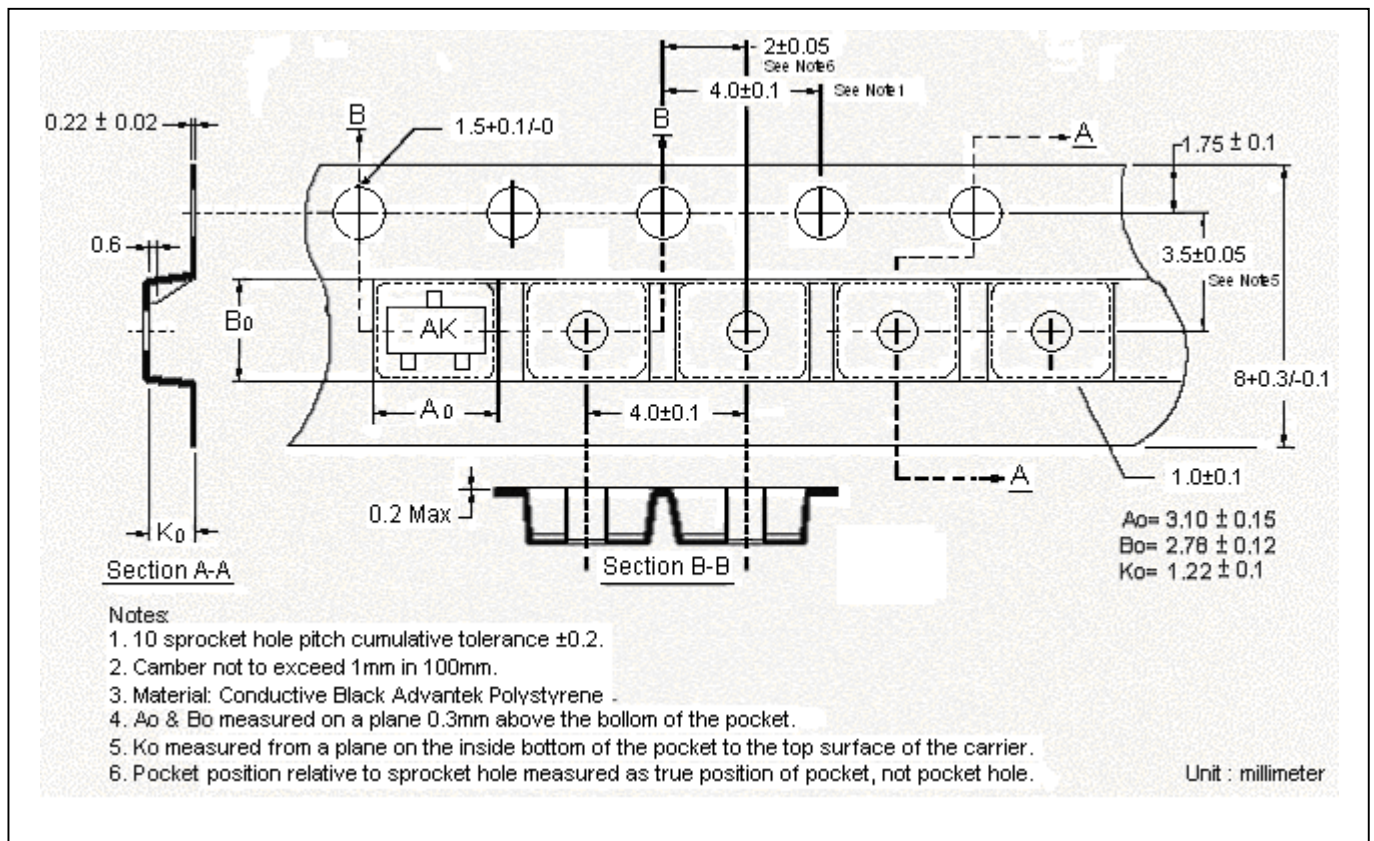

**SOT-23 Dimension**

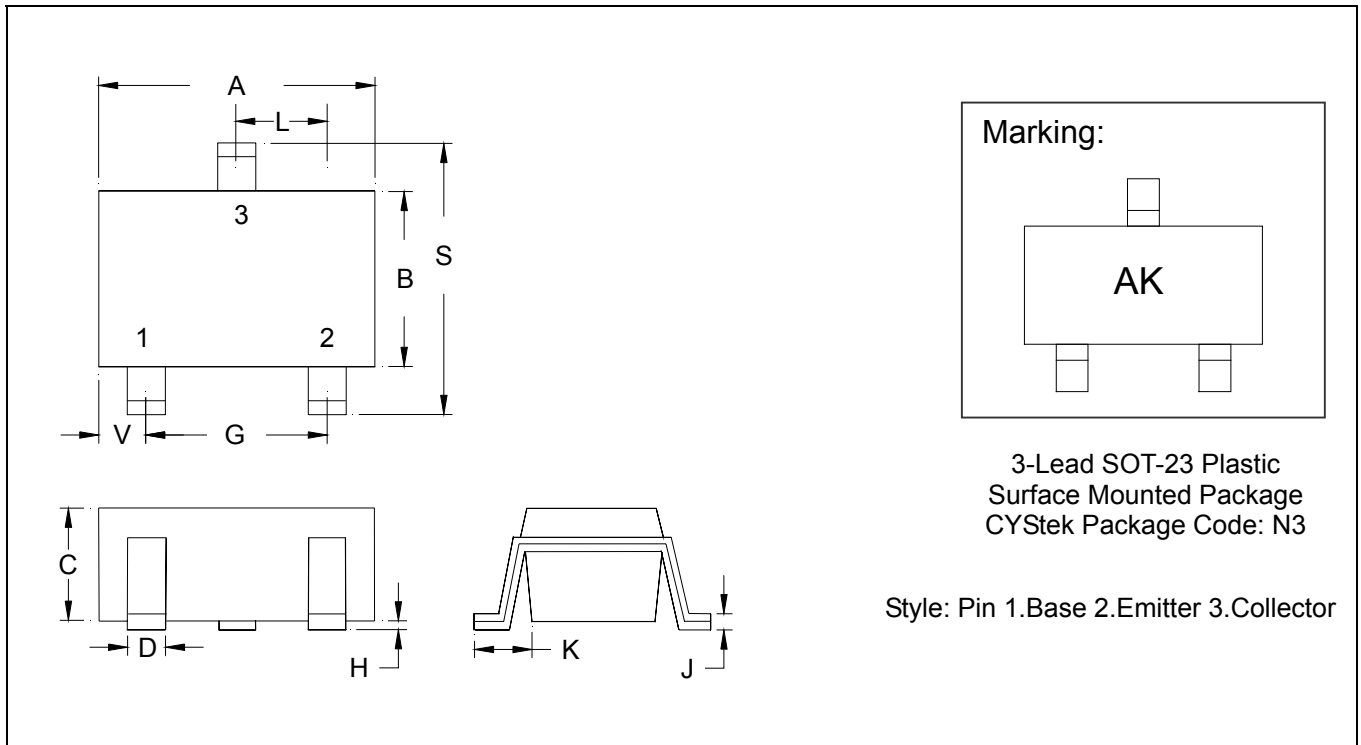

\*: Typical

DIM	Inches		Millimeters		DIM	Inches		Millimeters	
	Min.	Max.	Min.	Max.		Min.	Max.	Min.	Max.
A	0.1102	0.1204	2.80	3.04	J	0.0034	0.0070	0.085	0.177
B	0.0472	0.0630	1.20	1.60	K	0.0128	0.0266	0.32	0.67
C	0.0335	0.0512	0.89	1.30	L	0.0335	0.0453	0.85	1.15
D	0.0118	0.0197	0.30	0.50	S	0.0830	0.1083	2.10	2.75
G	0.0669	0.0910	1.70	2.30	V	0.0098	0.0256	0.25	0.65
H	0.0005	0.0040	0.013	0.10					

Notes: 1.Controlling dimension: millimeters.  
 2.Maximum lead thickness includes lead finish thickness, and minimum lead thickness is the minimum thickness of base material.  
 3.If there is any question with packing specification or packing method, please contact your local CYStek sales office.

**Material:**

- Lead: 42 Alloy ; solder plating
- Mold Compound: Epoxy resin family, flammability solid burning class: UL94V-0

**Important Notice:**

- All rights are reserved. Reproduction in whole or in part is prohibited without the prior written approval of CYStek.
- CYStek reserves the right to make changes to its products without notice.
- CYStek **semiconductor products are not warranted to be suitable for use in Life-Support Applications, or systems.**
- CYStek assumes no liability for any consequence of customer product design, infringement of patents, or application assistance.