

Low Saturation PNP Epitaxial Planar Transistor

BTB1197N3

Description

The BTB1197N3 is designed with high current gain and low saturation voltage with collector current up to 1A continuous.

Features

- Low $V_{CE(SAT)}$, $V_{CE(SAT)} \leq -0.3V$ ($I_C / I_B = -1A / -100mA$)
- Large collector current, $I_C = -1A$
- Complementary to BTD1781N3.
- Pb-free package

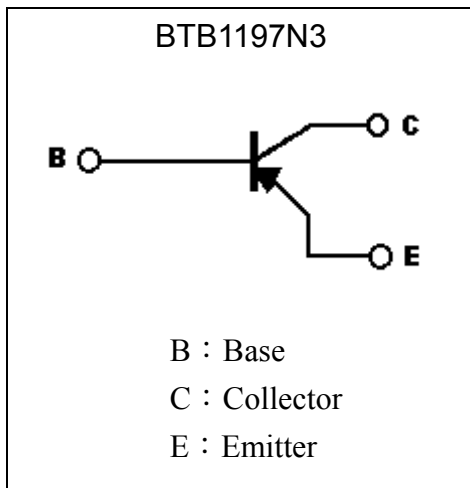
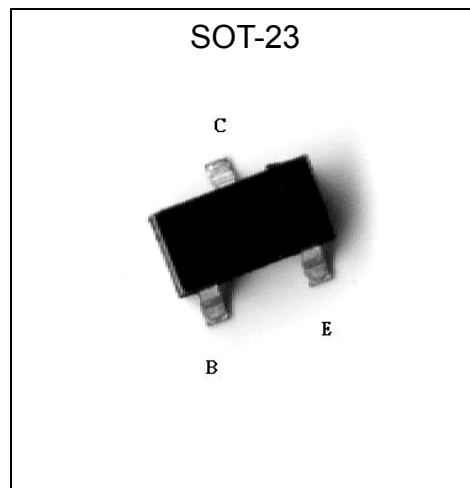
Symbol**Outline**

**Absolute Maximum Ratings** (Ta=25°C)

Parameter	Symbol	Limits	Unit
Collector-Base Voltage	V _{CBO}	-50	V
Collector-Emitter Voltage	V _{CEO}	-32	V
Emitter-Base Voltage	V _{EBO}	-5	V
Collector Current (DC)	I _C	-1	A
Collector Current (Pulse)	I _{CP}	-2	
Power Dissipation	P _d	310 (Note 1)	mW
		500 (Note 2)	
Thermal Resistance, Junction to Ambient	R _{θJA}	403 (Note 1)	°C/W
		250 (Note 2)	
Junction Temperature	T _j	-55~+150	°C
Storage Temperature	T _{stg}	-55~+150	°C

Note: 1. Device mounted on FR-4 PCB with minimum pad

2. Device mounted on FR-4 PCB with area of 4.5"x5", mounting pad 0.02 in² of 2 oz copper

Characteristics (Ta=25°C)

Symbol	Min.	Typ.	Max.	Unit	Test Conditions
B _V C _{BO}	-40	-	-	V	I _C =-50μA
B _V C _{EO}	-32	-	-	V	I _C =-1mA
B _V E _{BO}	-5	-	-	V	I _E =-50μA
I _{CBO}	-	-	-100	nA	V _{CB} =-30V
I _{EBO}	-	-	-100	nA	V _{EB} =-4V
*V _{CE(sat) 1}	-	-	-0.25	V	I _C =-500mA, I _B =-50mA
*V _{CE(sat) 2}	-	-	-0.30	V	I _C =-1A, I _B =-100mA
*V _{CE(sat) 3}	-	-	-0.65	V	I _C =-2A, I _B =-200mA
*V _{BE(sat)}	-	-	-1.2	V	I _C =-1A, I _B =-100mA
*V _{BE(on)}	-	-	-1.1	V	V _{CE} =-2V, I _C =-1A
*h _{FE 1}	180	-	420	-	V _{CE} =-3V, I _C =-100mA
*h _{FE 2}	100	-	-	-	V _{CE} =-2V, I _C =-500mA
*h _{FE 3}	80	-	-	-	V _{CE} =-2V, I _C =-1A
*h _{FE 4}	30	-	-	-	V _{CE} =-2V, I _C =-2A
f _T	100	200	-	MHz	V _{CE} =-5V, I _C =-50mA, f=100MHz
C _{ob}	-	12	25	pF	V _{CB} =-10V, f=1MHz

*Pulse Test: Pulse Width ≤380μs, Duty Cycle ≤2%

Characteristic Curves

Current Gain vs Collector Current

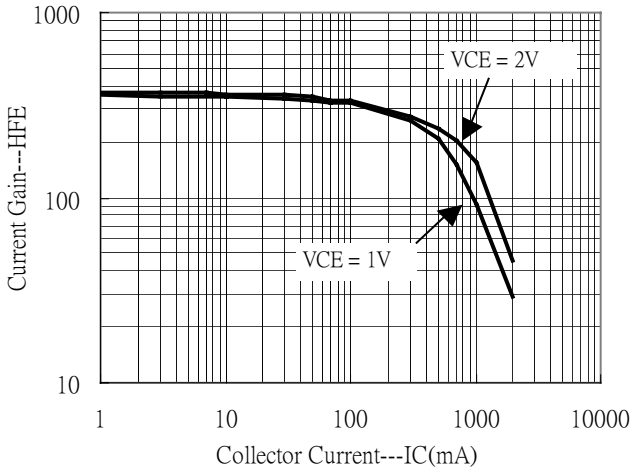

Saturation Voltage vs Collector Current

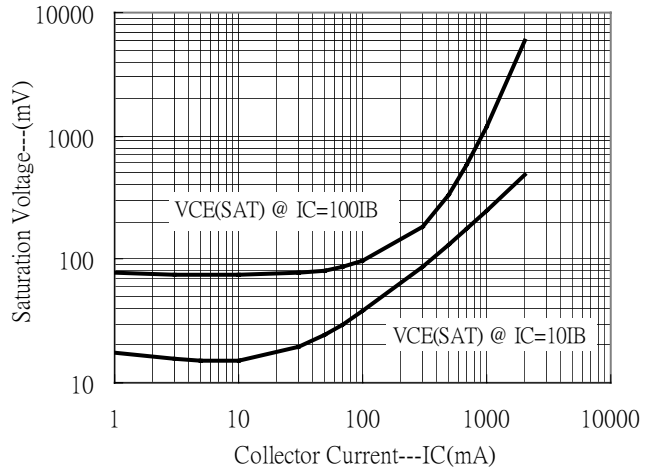

Saturation Voltage vs Collector Current

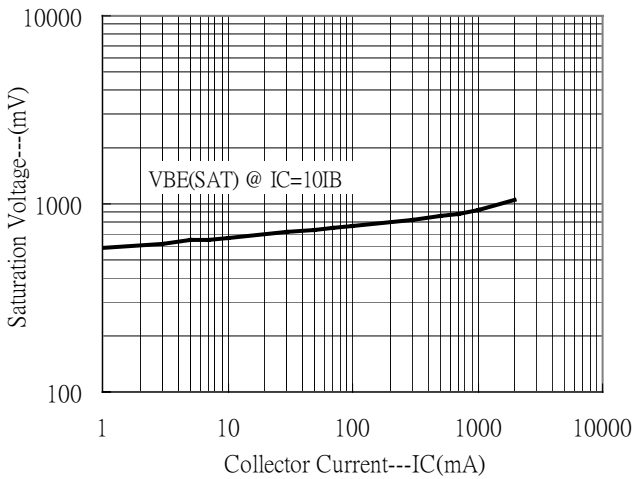

On Voltage vs Collector Current

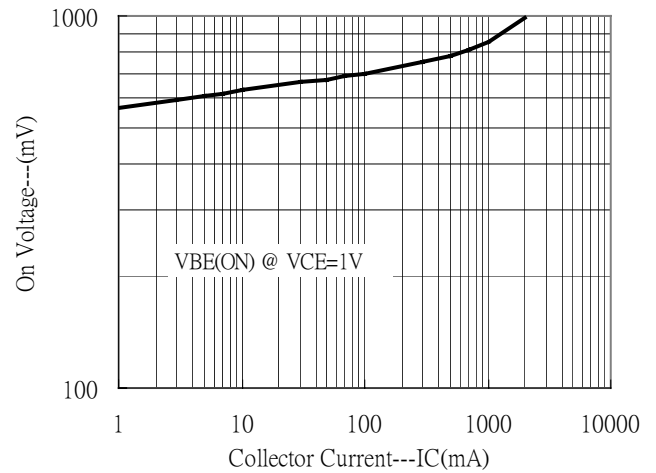

Power Derating Curves

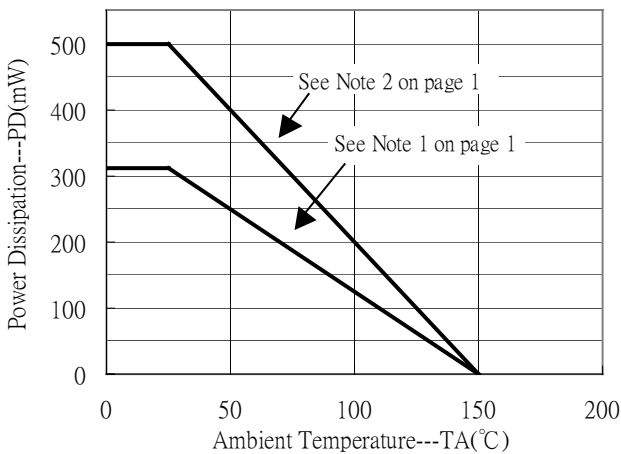

Reel Dimension

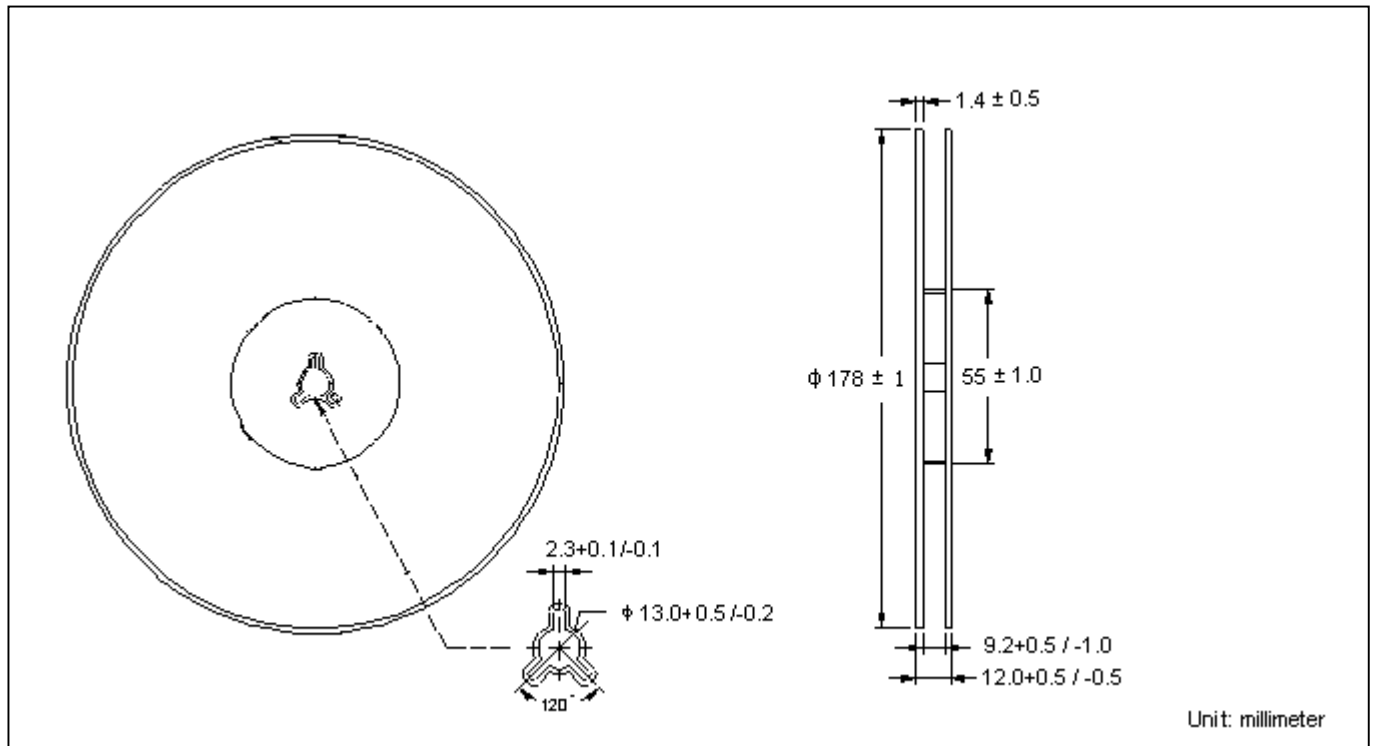

Carrier Tape Dimension

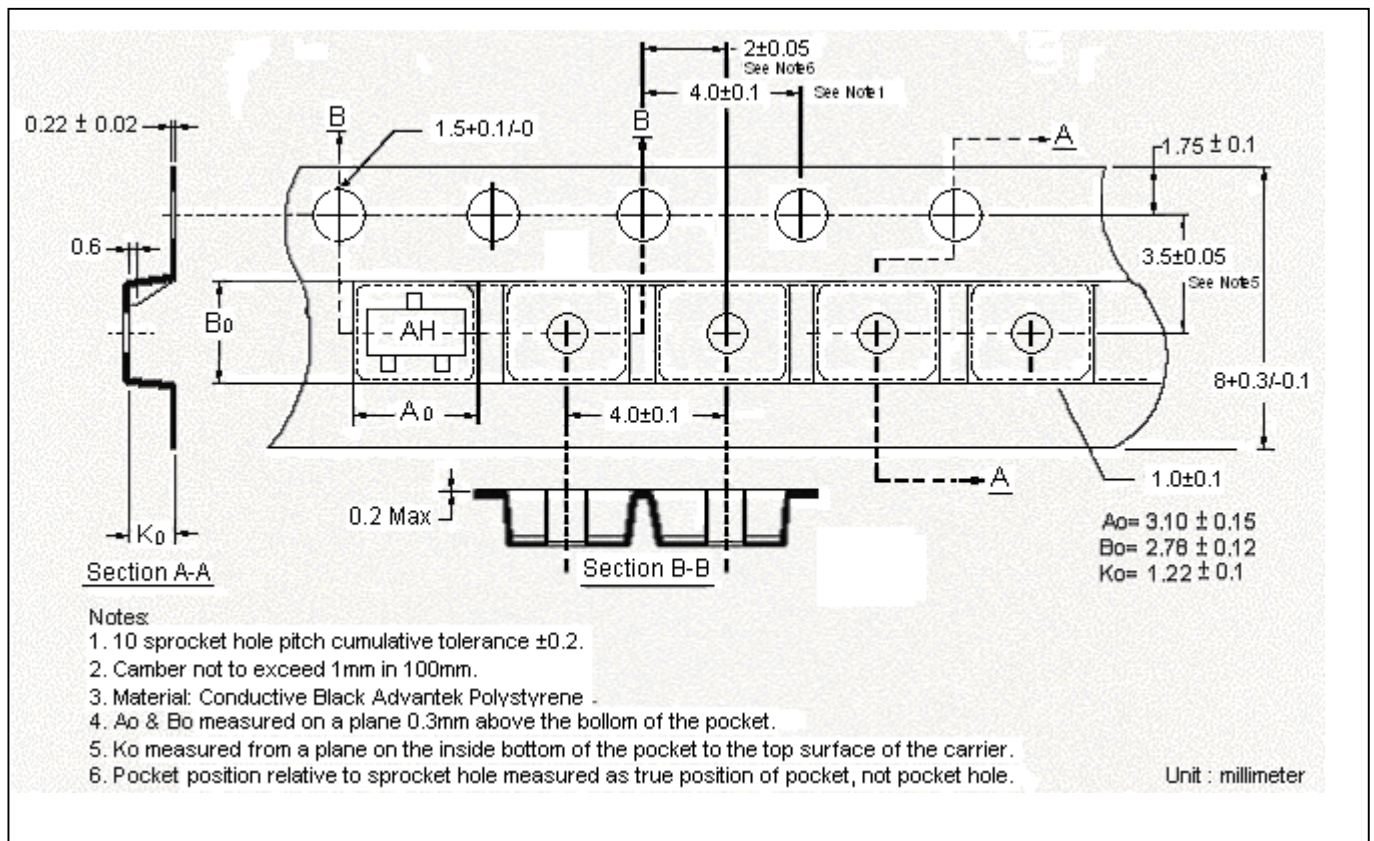

SOT-23 Dimension

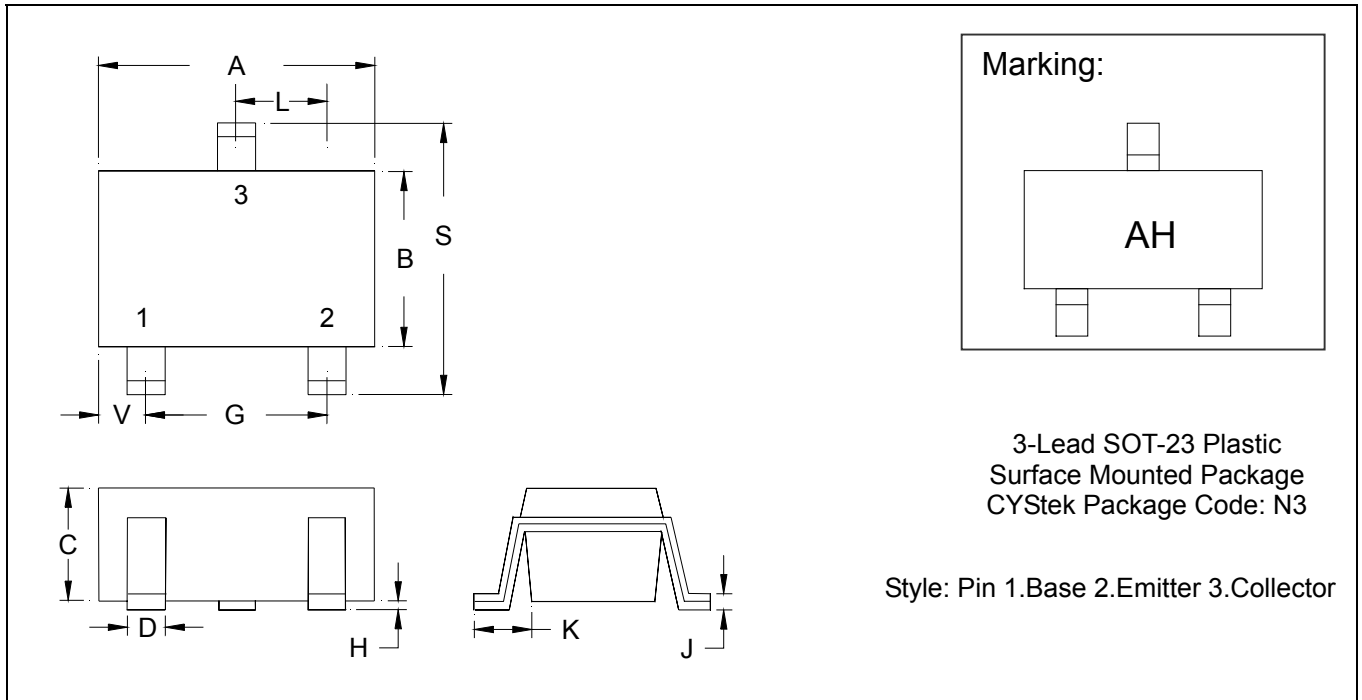

*: Typical

DIM	Inches		Millimeters		DIM	Inches		Millimeters	
	Min.	Max.	Min.	Max.		Min.	Max.	Min.	Max.
A	0.1102	0.1204	2.80	3.04	J	0.0034	0.0070	0.085	0.177
B	0.0472	0.0630	1.20	1.60	K	0.0128	0.0266	0.32	0.67
C	0.0335	0.0512	0.89	1.30	L	0.0335	0.0453	0.85	1.15
D	0.0118	0.0197	0.30	0.50	S	0.0830	0.1083	2.10	2.75
G	0.0669	0.0910	1.70	2.30	V	0.0098	0.0256	0.25	0.65
H	0.0005	0.0040	0.013	0.10					

Notes: 1.Controlling dimension: millimeters.
 2.Maximum lead thickness includes lead finish thickness, and minimum lead thickness is the minimum thickness of base material.
 3.If there is any question with packing specification or packing method, please contact your local CYStek sales office.

Material:

- Lead: 42 Alloy ; solder plating
- Mold Compound: Epoxy resin family, flammability solid burning class: UL94V-0

Important Notice:

- All rights are reserved. Reproduction in whole or in part is prohibited without the prior written approval of CYStek.
- CYStek reserves the right to make changes to its products without notice.
- CYStek **semiconductor products are not warranted to be suitable for use in Life-Support Applications, or systems.**
- CYStek assumes no liability for any consequence of customer product design, infringement of patents, or application assistance.