

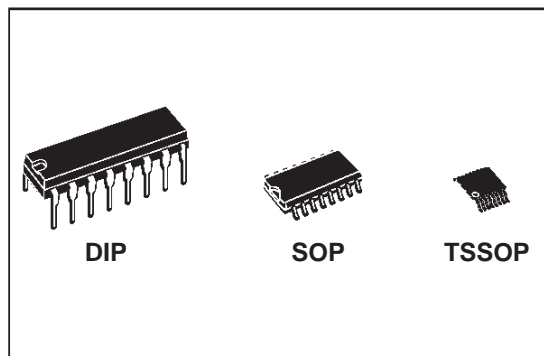

ST26C31

CMOS QUAD TRI-STATE DIFFERENTIAL LINE DRIVER

- TTL INPUT COMPATIBLE
- TYPICAL PROPAGATION DELAY: 6ns
- TYPICAL OUTPUT SKEW: 0.5ns
- OUTPUT WILL NOT LOAD LINE WHEN $V_{CC}=0V$
- MEETS THE REQUIREMENTS OF EIA STANDARD RS-422
- OPERATION FROM SINGLE 5V SUPPLY
- 3-STATE OUTPUTS FOR CONNECTION TO SYSTEM BUSES
- LOW QUIESCENT CURRENT
- AVAILABLE IN SURFACE MOUNT



DESCRIPTION

The ST26C31 is a quad differential line driver designed for digital data transmission over balanced lines and meets all the requirements of EIA standard RS-422 while retaining the low power characteristics of CMOS.

The ST26C31 accepts TTL or CMOS input levels

and translates these to RS-422 output levels. This part uses special outputs circuitry common to all four drivers. All outputs are protected against damage due to electrostatic discharge by diode to V_{CC} and ground.

ORDER CODES

Type	Temperature Range	Package	Comments
ST26C31BN	-40 to 85 °C	DIP-16	25 parts per tube / 40 tube per box
ST26C31BD	-40 to 85 °C	SO-16 (Tube)	50 parts per tube / 20 tube per box
ST26C31BDR	-40 to 85 °C	SO-16 (Tape & Reel)	2500 parts per reel
ST26C31BTR	-40 to 85 °C	TSSOP16 (Tape & Reel)	2500 parts per reel

PIN CONFIGURATION

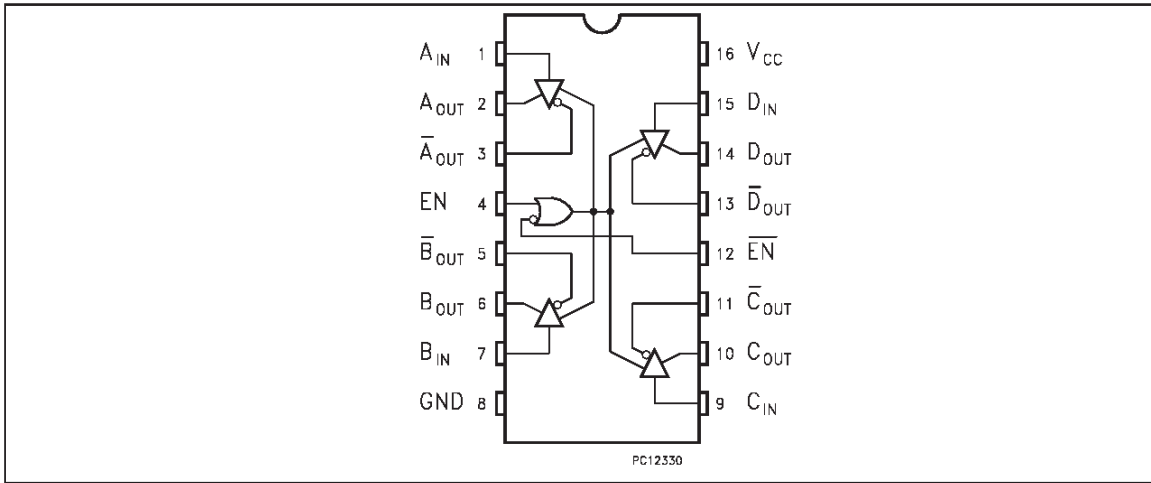

PIN DESCRIPTION

PIN No	SYMBOL	NAME AND FUNCTION
1	A _{IN}	INPUT A
2	A _{OUT}	Channel A Output
3	\bar{A}_{OUT}	Channel A Output
4	EN	ENABLE
5	\bar{B}_{OUT}	Channel B Output
6	B _{OUT}	Channel B Output
7	B _{IN}	INPUT B
8	GND	Ground
9	C _{IN}	INPUT C
10	C _{OUT}	Channel C Output
11	\bar{C}_{OUT}	Channel C Output
12	\bar{EN}	\bar{ENABLE}
13	\bar{D}_{OUT}	Channel D Output
14	D _{OUT}	Channel D Output
15	D _{IN}	INPUT D
16	V _{CC}	Supply Voltage

TRUTH TABLE

ENABLE	\bar{ENABLE}	INPUT	OUTPUT	\bar{OUTPUT}
L	H	X	Z	Z
All other combinations of enable inputs		L	L	H
		H	H	L

L=Low Voltage State
 H=High Logic State
 X=Don't Care
 Z=High Impedance

ABSOLUTE MAXIMUM RATINGS (Note 1, 2)

Symbol	Parameter	Value	Unit
V_{CC}	Supply Voltage	-0.5 to 7	V
V_{IN}	DC Input Voltage	- 0.5 to ($V_{CC} + 0.5$)	V
V_{OUT}	DC Output Voltage (High or Low State)	-0.5 to 7.0	V
I_{IK}	Clamp Diode Current	± 20	mA
I_{OUT}	DC Output Current per Pin	± 150	mA
I_{CC}	DC V_{CC} or GND Current	± 150	mA
T_{stg}	Storage Temperature Range	-65 to +150	°C

Note 1: Absolute Maximum Ratings are those values beyond which the safety of the device cannot be guaranteed. They are not meant to imply that the device should be operated at these limits. The table of electrical characteristics provide conditions for actual device operation.

Note 2: Unless otherwise specified, all voltage are referenced to ground. All currents into the device pins are positive; all currents out of the device pins are negative.

RECOMMENDED OPERATING CONDITIONS

Symbol	Parameter	Value	Unit
V_{CC}	Supply Voltage	4.5 to 5.5	V
V_{IN}	DC Input Voltage	0 to V_{CC}	V
V_{OUT}	DC Output Voltage (High or Low State)	0 to V_{CC}	V
V_{OUT}	DC Output Voltage ($V_{CC}=0V$ or High Impedance)	0 to 5	V
T_A	Operating Temperature Range	-40 to +85	°C
t_r, t_f	Maximum Enable Input Rise or Fall Times	500	ns

ELECTRICAL CHARACTERISTICS ($V_{CC} = 5V \pm 10\%$ unless otherwise specified, Note 1)

Symbol	Parameter	Test Conditions	Value			Unit	
			Min.	Typ.	Max.		
V_{IH}	High Level Input Voltage		2			V	
V_{IL}	Low Level Input Voltage				0.8	V	
V_{OH}	High Level Output Voltage	$V_{IN} = V_{IH}$ or V_{IL} , $I_{OUT} = -20mA$	2.5	3.4		V	
V_{OL}	Low Level Output Voltage	$V_{IN} = V_{IH}$ or V_{IL} , $I_{OUT} = +20mA$		0.3	0.5	V	
V_T	Differential Output Voltage	$R_L = 100 \Omega$ (Note 2)	2	3.1		V	
$V_T - \bar{V}_T$	Difference in Differential Output Voltage	$R_L = 100 \Omega$ (Note 2)			0.4	V	
V_{OS}	Common Mode Output Voltage	$R_L = 100 \Omega$ (Note 2)		1.8	3	V	
$ V_{OS} - V_{OS} $	Difference in Common Mode Output Voltage	$R_L = 100 \Omega$ (Note 2)			0.4	V	
I_{IN}	Input Current	$V_{IN} = V_{CC}, GND, V_{IH}$ or V_{IL}			± 1.0	μA	
I_{CC}	Quiescent Supply Current (Note 2)	$I_{OUT} = 0 \mu A$	$V_{IN} = V_{CC}$ or GND		200	500	μA
			$V_{IN} = 2.4$ or $0.5 V$ (Note 3)		0.8	2	mA
I_{OZ}	3-STATE Output Leakage Current	$V_{OUT} = V_{CC}$ or GND $ENABLE = V_{IL}$ $\bar{ENABLE} = V_{IH}$		± 0.5	± 5.0	μA	
I_{SC}	Output Short Circuit Current	$V_{IN} = V_{CC}$ or GND (Notes 2, 4)	-30		-150	mA	
I_{OFF}	Power Off Output Leakage Current (Note 2)	$V_{CC} = 0V$	$V_{OUT} = 6 V$			100	μA
			$V_{OUT} = -0.25 V$			-100	μA

Note 1: Unless otherwise specified, min/max limits apply across the recommended operating temperature range. All typicals are given for $V_{CC}=5V$ and $T_a=25^\circ C$

Note 2: See EIA Specification RS422 for exact test conditions.

Note 3: Measured per pin input. All other input at V_{CC} or GND

Note 4: This is the current sourced when a high output is shorted to ground. Only one output at time should be shorted.

SWITCHING CHARACTERISTICS ($V_{CC} = 5V \pm 10\%$, $t_r = t_f \leq 6ns$, See Note 1)

Symbol	Parameter	Test Conditions	Value			Unit
			Min.	Typ.	Max.	
t_{PLH} t_{PHL}	Propagation Delay Input to Output	S1 Open	2	6	11	ns
Skew	(Note 2)	S1 Open		0.5	2	ns
t_{TLH} t_{THL}	Differential Output Rise and Fall Times	S1 Open		6	10	ns
t_{PZH}	Output Enable Time	S1 Closed		11	19	ns
t_{PZL}	Output Enable Time	S1 Closed		13	21	ns
t_{PHZ}	Output Disable Time (Note 3)	S1 Closed		5	9	ns
t_{PLZ}	Output Disable Time (Note 3)	S1 Closed		7	11	ns
C_{PD}	Power Dissipation Capacitance (Note 4)			50		pF
C_{IN}	Input Capacitance			6		pF

Note 1: Unless otherwise specified, min/max limits apply across the recommended operating temperature range. All typicals are given for $V_{CC} = 5V$ and $T_a = 25^\circ C$

Note 2: Skew is defined as the difference in propagation delays between complementary outputs at the 50% point.

Note 3: Output disable time is the delay from the control input being switched to the output transistors turning off. The actual disable times are less than indicated due to the delay added by RC time constant of the load.

Note 4: C_{PD} determines the no load dynamic power consumption, $P_D = C_{PD} V_{CC}^2 f + I_{CC} V_{CC}$, and the no load dynamic current consumption, $P_D = C_{PD} V_{CC} f + I_{CC}$

Plastic DIP-16 (0.25) MECHANICAL DATA

DIM.	mm			inch		
	MIN.	TYP.	MAX.	MIN.	TYP.	MAX.
a1	0.51			0.020		
B	0.77		1.65	0.030		0.065
b		0.5			0.020	
b1		0.25			0.010	
D			20			0.787
E		8.5			0.335	
e		2.54			0.100	
e3		17.78			0.700	
F			7.1			0.280
l			5.1			0.201
L		3.3			0.130	
Z			1.27			0.050

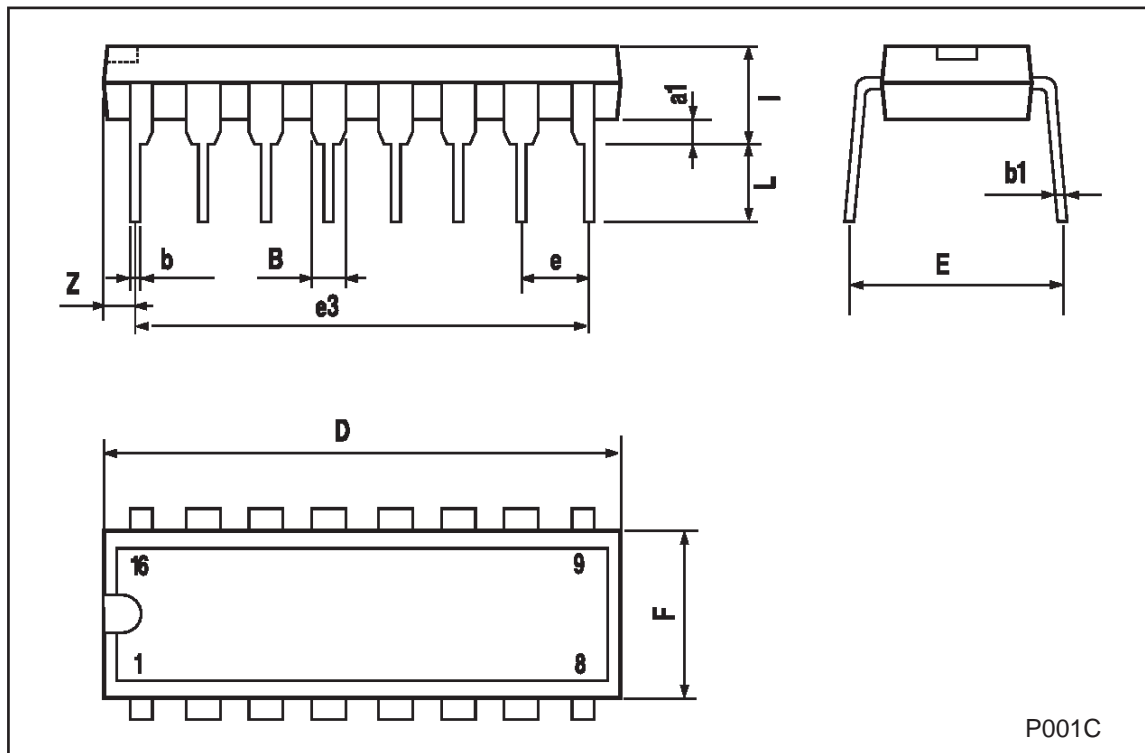

SO-16 MECHANICAL DATA

DIM.	mm			inch		
	MIN.	TYP.	MAX.	MIN.	TYP.	MAX.
A			1.75			0.068
a1	0.1		0.2	0.004		0.007
a2			1.65			0.064
b	0.35		0.46	0.013		0.018
b1	0.19		0.25	0.007		0.010
C		0.5			0.019	
c1	45 (typ.)					
D	9.8		10	0.385		0.393
E	5.8		6.2	0.228		0.244
e		1.27			0.050	
e3		8.89			0.350	
F	3.8		4.0	0.149		0.157
G	4.6		5.3	0.181		0.208
L	0.5		1.27	0.019		0.050
M			0.62			0.024
S	8 (max.)					

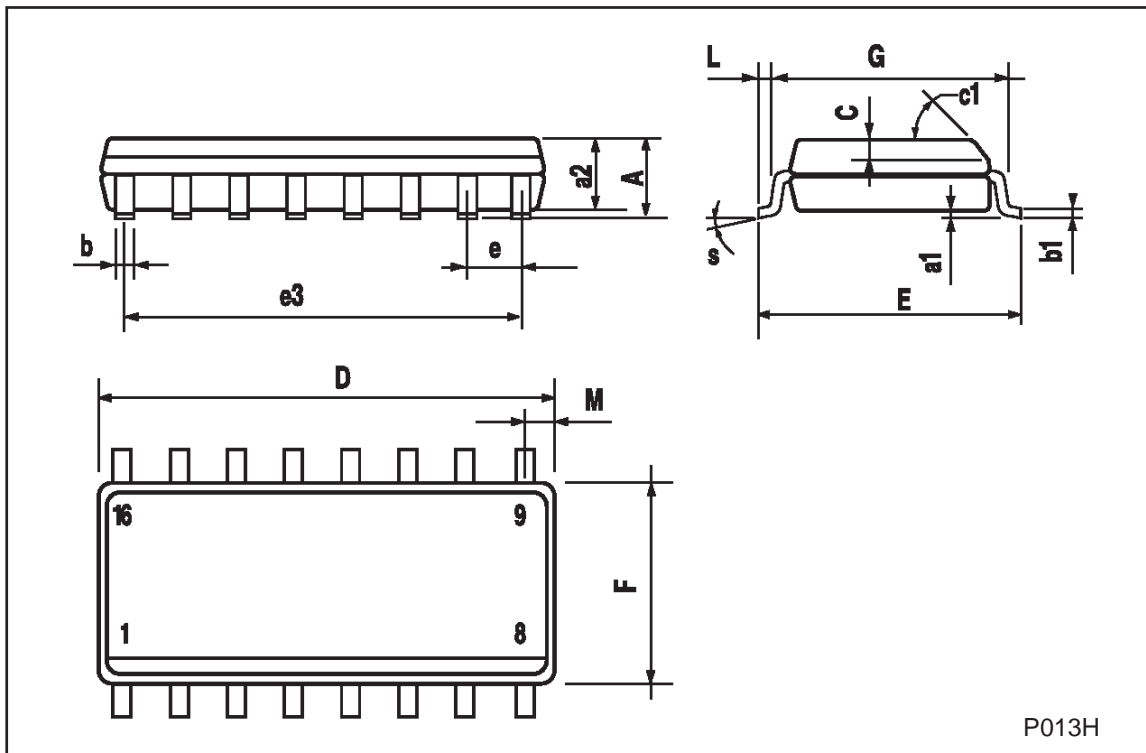

P013H

TSSOP16 MECHANICAL DATA

DIM.	mm			inch		
	MIN.	TYP.	MAX.	MIN.	TYP.	MAX.
A			1.1			0.433
A1	0.05	0.10	0.15	0.002	0.004	0.006
A2	0.85	0.9	0.95	0.335	0.354	0.374
b	0.19		0.30	0.0075		0.0118
c	0.09		0.20	0.0035		0.0079
D	4.9	5	5.1	0.193	0.197	0.201
E	6.25	6.4	6.5	0.246	0.252	0.256
E1	4.3	4.4	4.48	0.169	0.173	0.176
e		0.65 BSC			0.0256 BSC	
K	0°	4°	8°	0°	4°	8°
L	0.50	0.60	0.70	0.020	0.024	0.028

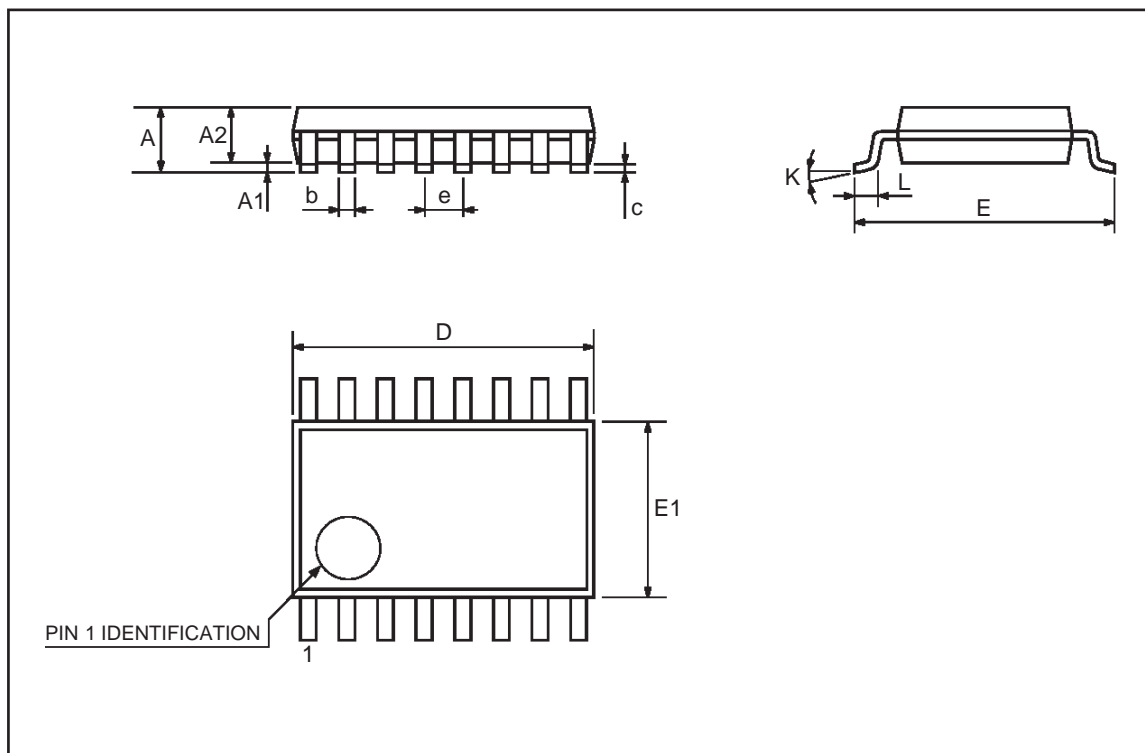

Information furnished is believed to be accurate and reliable. However, STMicroelectronics assumes no responsibility for the consequences of use of such information nor for any infringement of patents or other rights of third parties which may result from its use. No license is granted by implication or otherwise under any patent or patent rights of STMicroelectronics. Specification mentioned in this publication are subject to change without notice. This publication supersedes and replaces all information previously supplied. STMicroelectronics products are not authorized for use as critical components in life support devices or systems without express written approval of STMicroelectronics.

The ST logo is a registered trademark of STMicroelectronics

© 2000 STMicroelectronics – Printed in Italy – All Rights Reserved

STMicroelectronics GROUP OF COMPANIES

Australia - Brazil - China - Finland - France - Germany - Hong Kong - India - Italy - Japan - Malaysia - Malta - Morocco
Singapore - Spain - Sweden - Switzerland - United Kingdom - U.S.A.

<http://www.st.com>