

LED LAMP

# TRIANGULAR TYPE

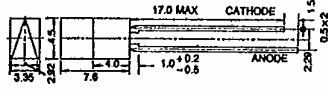
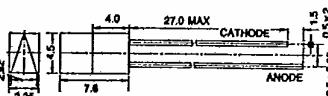
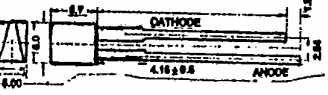
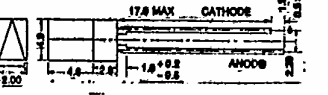
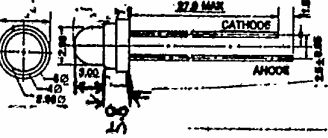
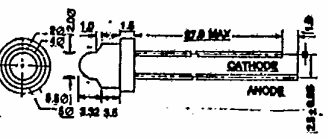

TRIANGULAR TYPE	LENS COLOR				EMITTING COLOR	LUMINOUS INTENSITY IN MCD @10MA			
	Color Diffused (TYP 1)	Color Transparent (TYP 2)	White Diffused (TYP 3)	Water Clear (TYP 4)		TYP			
						1	2	3	4
 <p>3x4.6m/m</p> <p>As sample in P25-44</p>	T1123		T1323		Red GaAsP	0.6		0.6	
	T2123		T2323		Yellow	1.2		1.2	
	T3123		T3323		Green	1.4		1.4	
	T3123P		T3323P		Pure Green	1.2		1.2	
	T4123		T4323		Orange	2.0		2.0	
	T5123		T5323		Red GaP	1.2		1.2	
	T7123		T7323		Low Current Red	1.6		1.6	
	 <p>3x4.6m/m</p> <p>As sample in P25-44</p>	T1133		T1333		Red GaAsP	1.1		1.1
T2133			T2333		Yellow	2.1		2.1	
T3133			T3333		Green	2.5		2.5	
T3133P			T3333P		Pure Green	2.1		2.1	
T4133			T4333		Orange	2.6		2.6	
T5133			T5333		Red GaP	2.1		2.1	
T7133			T7333		Low Current Red	2.5		2.5	
		T1114		T1314		Red GaAsP	0.6		0.6
	T2114		T2314		Yellow	1.2		1.2	
	T3114		T3314		Green	1.4		1.4	
	T3114P		T3314P		Pure Green	1.2		1.2	
	T4114		T4314		Orange	2.0		2.0	
	T5114		T5314		Red GaP	1.2		1.2	
	T7114		T7314		Low Current Red	1.6		1.6	
		T1122		T1322		Red GaAsP	0.6		0.6
T2122			T2322		Yellow	1.2		1.2	
T3122			T3322		Green	1.4		1.4	
T3122P			T3322P		Pure Green	1.2		1.2	
T4122			T4322		Orange	2.0		2.0	
T5122			T5322		Red GaP	1.2		1.2	
T7122			T7322		Low Current Red	1.6		1.6	
		S1137		S1237		Red GaAsP	1.9		5.0
	S2137		S2237		Yellow	3.7		9.8	
	S3137		S3237		Green	4.3		11.4	
	S3137P		S3237P		Pure Green	3.7		9.8	
	S4137		S4237		Orange	4.7		12.8	
	S5137		S5237		Red GaP	3.7		9.8	
	S7137		S7237		Red GaAlAs	4.5		12.5	
	Low Current Red								
	S1136		S1236		Red GaAsP	1.9		5.0	
	S2136		S2236		Yellow	3.7		9.8	
	S3136		S3236		Green	4.3		11.4	
	S3136P		S3236P		Pure Green	3.7		9.8	
	S4136		S4236		Orange	4.7		12.8	
	S5136		S5236		Red GaP	3.7		9.8	
	S7136		S7236		Red GaAlAs	4.5		12.5	
	Low Current Red								

# HOLDER TYPE

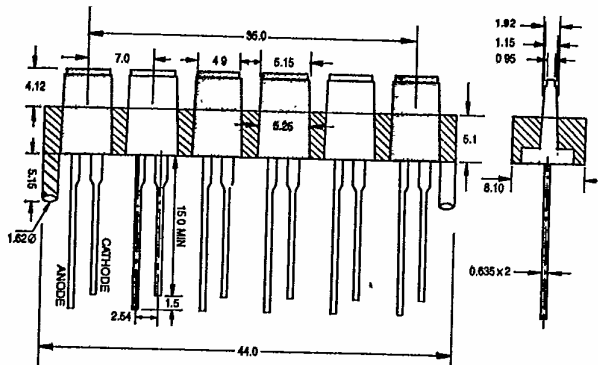

**H-1** 1x5m/m ARRAY SOCKET 6 SEGUENT

As sample in P25-58

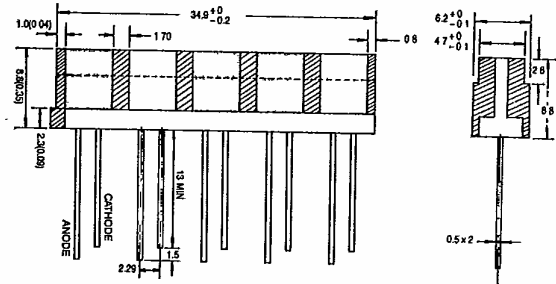

**H-2** 1.8x5.3m/m ARRAY SOCKET 5 SEGUENT

As sample in P25-99

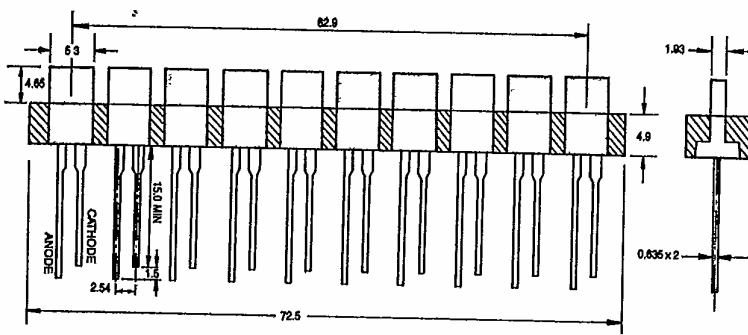

**H-3** 1.8x5.3m/m ARRAY SOCKET 10 SEGUENT

As sample in P25-60

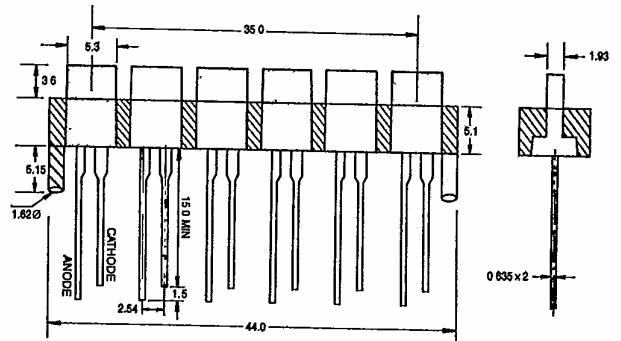

**H-4** 1.8x5.3m/m ARRAY SOCKET 6 SEGUENT

As sample in P25-61

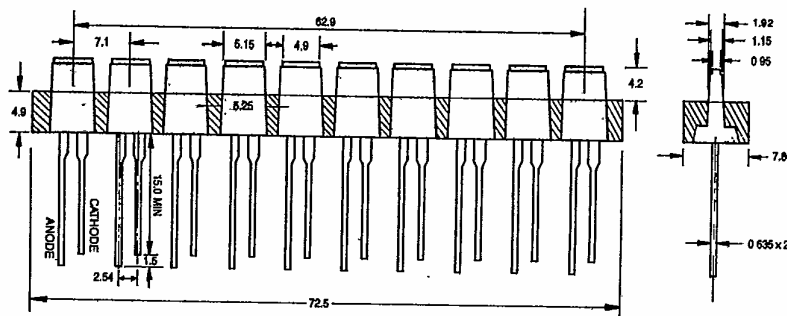

**H-5** 1x5m/m ARRAY SOCKET 10 SEGUENT

As sample in P25-62

All Dimensions are in millimeters.  
Tolerance is  $\pm 0.2\text{mm}$

# HOLDER TYPE

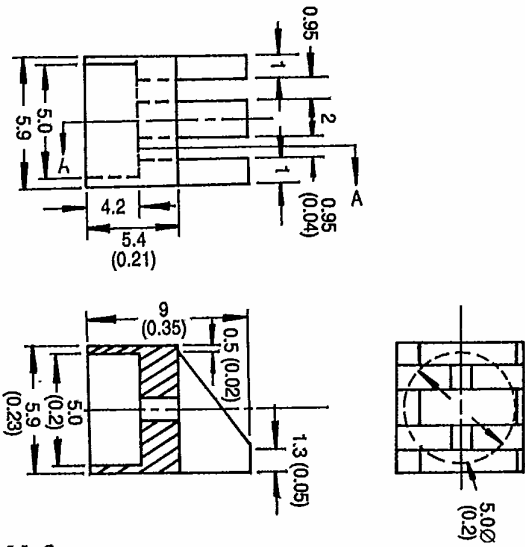

**H-6** 5m/m

As sample in P25-63

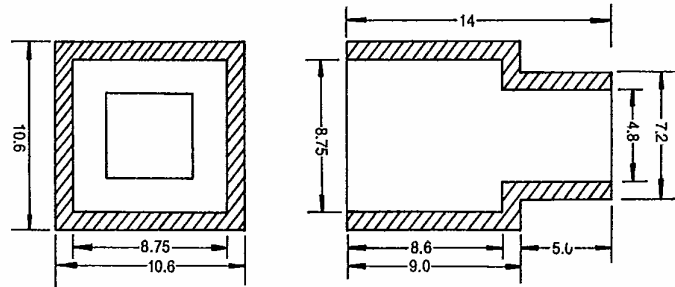

**H-7** 8x8m/m

As sample in P25-64

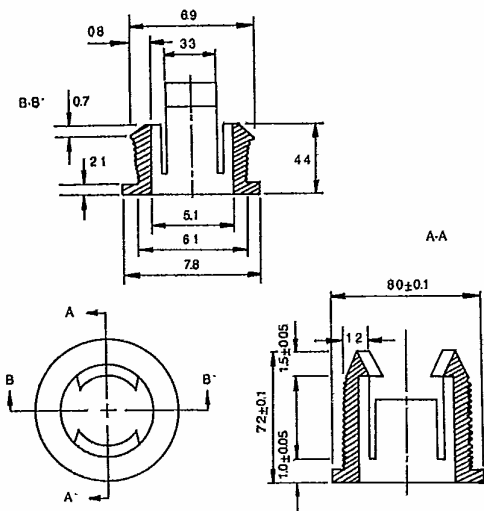

**H-8** 5m/m

As sample in P25-65

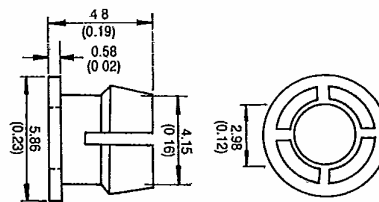

**H-9** 3m/m

As sample in P25-66

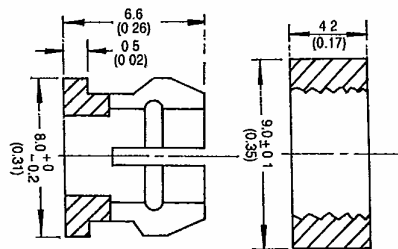

**H-10** 5m/m

As sample in P25-67

All Dimensions are in millimeters.  
Tolerance is  $\pm 0.2\text{mm}$